

## Mitsubishi Programmable Controller

### Digital-Analog Converter Module type AJ65BT-64DAV/DAI User's Manual

---

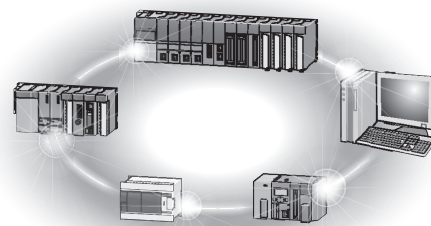



# • SAFETY PRECAUTIONS •

(Read these precautions before using this product.)

Before using this product, please read this manual and the relevant manuals carefully and pay full attention to safety to handle the product correctly.

The instructions given in this manual are concerned with this product. Refer to the user's manual of the CPU module to use for a description of the programmable controller system safety instructions.

In this manual, the safety precautions are classified into two levels: "⚠ WARNING" and "⚠ CAUTION".



Indicates that incorrect handling may cause hazardous conditions, resulting in death or severe injury.

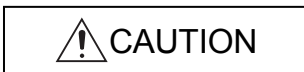

Indicates that incorrect handling may cause hazardous conditions, resulting in minor or moderate injury or property damage.

Under some circumstances, failure to observe the precautions given under "⚠ CAUTION" may lead to serious consequences.

Observe the precautions of both levels because they are important for personal and system safety. Make sure that the end users read this manual and then keep the manual in a safe place for future reference.

## [Design Precautions]

### ⚠ WARNING

- Install a safety circuit external to the programmable controller that keeps the entire system safe even when there are problems with the external power supply or the programmable controller. Otherwise, trouble could result from erroneous output or erroneous operation.
  - (1) The status of analog output changes depending on the setting of various functions that control the analog output. Take sufficient caution when setting for those functions. For details of analog output status, refer to Section 3.4.5 "Combinations of various functions"
  - (2) Normal output may not be obtained due to malfunctions of output elements or the internal circuits. So build an external monitoring circuit that will monitor any single outputs that could cause serious trouble.

### ⚠ CAUTION

- Do not bunch the control wires or communication cables with the main circuit or power wires, or install them close to each other. They should be installed 100mm(3.94inch) or more from each other. Not doing so could result in noise that would cause erroneous operation.
- At power ON/OFF, voltage or current may instantaneously be output from the output terminal of this module. In such case, wait until the analog output becomes stable to start controlling the external device.

## [Installation Precautions]

### CAUTION

- Use the module in the environment given in the general specifications of this Manual.  
Using this programmable controller in an environment outside the range of the general specifications could result in electric shock, fire, erroneous operation, and damage to or deterioration of the product.
- For protection of the switches, do not remove the cushioning material before installation.
- Securely fix the module with a DIN rail or mounting screws. Tighten the screws within the specified torque range.  
Undertightening can cause drop of the screw, short circuit, or malfunction.  
Overtightening can damage the screw and/or module, resulting in drop, short circuit, or malfunction.
- Do not directly touch the module's conductive parts or electronic components.  
Touching the conductive parts could cause an operation failure or give damage to the module.

## [Wiring Precautions]

### CAUTION

- Shut off the external power supply for the system in all phases before wiring.  
Failure to do so may result in damage to the product.
- Be sure to ground the FG terminals to the protective ground conductor. Not doing so could result in erroneous operation.
- Use applicable solderless terminals and tighten them with the specified torque. If any solderless spade terminal is used, it may be disconnected when the terminal screw comes loose, resulting in failure.
- When wiring in the programmable controller, be sure that it is done correctly by checking the product's rated voltage and the terminal layout.  
Connecting a power supply that is different from the rating or incorrectly wiring the product could result in fire or damage.
- Tighten the terminal screws with the specified torque.  
If the terminal screws are loose, it could result in short circuits, fire, or erroneous operation.  
Overtightening can damage the screw and/or module, resulting in drop, short circuit, or malfunction.
- Be sure there are no foreign substances such as sawdust or wiring debris inside the module.  
Such debris could cause fires, damage, or erroneous operation.
- Do not install the control lines together with the communication cables, or bring them close to each other. Failure to do so may cause malfunctions due to noise.
- When connecting the communication and power supply cables to the module, always run them in conduits or clamp them.  
Not doing so can damage the module and cables due to loose, moved or accidentally pulled cables or can cause a malfunction due to a cable connection fault.

## [Wiring Precautions]

### CAUTION

- When disconnecting the communication and power supply cables from the module, do not hold and pull the cable part.  
Disconnect the cables after loosening the screws in the portions connected to the module.  
Pulling the cables connected to the module can damage the module and cables or can cause a malfunction due to a cable connection fault.

## [Starting and Maintenance Precautions]

### CAUTION

- Do not touch the terminals while power is on. Doing so may cause malfunctioning.
- Be sure to shut off all phases of the external power supply used by the system before cleaning or retightening the terminal screws.  
Not doing so can cause the module to fail or malfunction.
- Do not disassemble or modify the modules.  
Doing so could cause trouble, erroneous operation, injury, or fire.
- Do not drop or apply strong shock to the module. Doing so may damage the module.
- Be sure to shut off all phases of the external power supply used by the system before mounting or dismounting the module to or from the panel.  
Not doing so could result in damage to the product.
- Do not install/remove the terminal block more than 50 times after the first use of the product.  
(IEC 61131-2 compliant)
- Before touching the module, always touch grounded metal, etc. to discharge static electricity from human body.  
Failure to do so can cause the module to fail or malfunction.

## [Disposal Precautions]

### CAUTION

- When disposing of this product, treat it as industrial waste.

## • CONDITIONS OF USE FOR THE PRODUCT •

- (1) Mitsubishi programmable controller ("the PRODUCT") shall be used in conditions;
- i) where any problem, fault or failure occurring in the PRODUCT, if any, shall not lead to any major or serious accident; and
  - ii) where the backup and fail-safe function are systematically or automatically provided outside of the PRODUCT for the case of any problem, fault or failure occurring in the PRODUCT.

- (2) The PRODUCT has been designed and manufactured for the purpose of being used in general industries.

MITSUBISHI SHALL HAVE NO RESPONSIBILITY OR LIABILITY (INCLUDING, BUT NOT LIMITED TO ANY AND ALL RESPONSIBILITY OR LIABILITY BASED ON CONTRACT, WARRANTY, TORT, PRODUCT LIABILITY) FOR ANY INJURY OR DEATH TO PERSONS OR LOSS OR DAMAGE TO PROPERTY CAUSED BY the PRODUCT THAT ARE OPERATED OR USED IN APPLICATION NOT INTENDED OR EXCLUDED BY INSTRUCTIONS, PRECAUTIONS, OR WARNING CONTAINED IN MITSUBISHI'S USER, INSTRUCTION AND/OR SAFETY MANUALS, TECHNICAL BULLETINS AND GUIDELINES FOR the PRODUCT.

("Prohibited Application")

Prohibited Applications include, but not limited to, the use of the PRODUCT in;

- Nuclear Power Plants and any other power plants operated by Power companies, and/or any other cases in which the public could be affected if any problem or fault occurs in the PRODUCT.
- Railway companies or Public service purposes, and/or any other cases in which establishment of a special quality assurance system is required by the Purchaser or End User.
- Aircraft or Aerospace, Medical applications, Train equipment, transport equipment such as Elevator and Escalator, Incineration and Fuel devices, Vehicles, Manned transportation, Equipment for Recreation and Amusement, and Safety devices, handling of Nuclear or Hazardous Materials or Chemicals, Mining and Drilling, and/or other applications where there is a significant risk of injury to the public or property.

Notwithstanding the above, restrictions Mitsubishi may in its sole discretion, authorize use of the PRODUCT in one or more of the Prohibited Applications, provided that the usage of the PRODUCT is limited only for the specific applications agreed to by Mitsubishi and provided further that no special quality assurance or fail-safe, redundant or other safety features which exceed the general specifications of the PRODUCTS are required. For details, please contact the Mitsubishi representative in your region.

REVISIONS

\* The manual number is given on the bottom left of the back cover.

Print Date	* Manual Number	Revision
Jan., 1997	SH(NA)-3615-A	First printing
Jun., 2000	SH(NA)-3615-B	Addition of Q series types  Chapter 2, Section 3.2, Section 3.4.1, Section 3.6.3, Section 4.2, Section 6.2  <b>Partial changes</b>  Section 1.1(3), Section 3.1, Section 3.2, Section 3.4.5, Section 4.1, Section 4.6.2, Section 4.7.2, Section 5.2
Sep., 2004	SH(NA)-3615-C	<b>Addition</b> Conformation to the EMC Directive and Low Voltage Instruction  <b>Correction</b>  SAFETY PRECAUTIONS, About this Manual, Chapter 1, Chapter 2, Section 3.1, Section 3.2, Section 3.6.4, Section 3.6.5, Section 4.1, Section 4.4, Section 4.6, Section 4.6.1, Section 4.6.2, Section 4.7.2, Chapter 5, Section 6.2
Jul., 2005	SH(NA)-3615-D	<b>Correction</b>  SAFETY PRECAUTIONS
Oct., 2006	SH(NA)-3615-E	<b>Correction</b>  SAFETY PRECAUTIONS, Section 4.2
Dec., 2006	SH(NA)-3615-F	<b>Partial correction</b>  Chapter 2(1), Section 3.5.1, Chapter 5
Dec., 2010	SH(NA)-3615-G	<b>Addition</b> CONDITIONS OF USE FOR THE PRODUCT  <b>Correction</b>  SAFETY PRECAUTIONS, Chapter 1, Section 1.1, Chapter 2, Section 3.1 to Section 3.5, Section 3.5.2, Section 3.6.1, Section 3.6.2, Section 4.1, Section 4.3, Section 4.6.2, Section 4.7.1, Section 5.1, Section 5.1, Section 5.2, Section 5.3, Section 5.6, Chapter 6, Section 6.1, Section 6.2, Appendix 2  <b>Delection</b>  Section 4.6.1

Japanese Manual Version SH-3600-I

This manual does not imply guarantee or implementation right for industrial ownership or implementation of other rights. Mitsubishi Electric Corporation is not responsible for industrial ownership problems caused by use of the contents of this manual.

## Introduction

Thank you for purchasing the Mitsubishi MELSEC-A Series General Purpose Programmable Controller. Before using the equipment, please read this manual carefully to develop full familiarity with the functions and performance of the graphic operation terminal you have purchased, so as to ensure correct use. Please forward a copy of this manual to the end user.

## Table of Contents

<b>1. OVERVIEW</b>	<b>1- 1 to 1- 2</b>
1.1 Features .....	1- 1
<b>2. SYSTEM CONFIGURATION</b>	<b>2- 1 to 2- 2</b>
<b>3. SPECIFICATIONS</b>	<b>3- 1 to 3-14</b>
3.1 General Specification .....	3- 1
3.2 Performance Specification .....	3- 2
3.3 I/O Conversion Characteristics .....	3- 4
3.3.1 Offset value and gain value .....	3- 4
3.3.2 I/O conversion characteristics .....	3- 4
3.4 Various Functions to Control the Analog Output .....	3- 8
3.4.1 Function to specify hold or clear of the analog output when the programmable controller CPU is in the STOP status (HOLD/CLEAR setting) .....	3- 8
3.4.2 Function to specify executing or not executing the D/A conversion processing (Analog output enable/disable flag) .....	3- 8
3.4.3 Function to specify enabling or prohibiting of the analog value external output (Analog output enable/prohibit setting) .....	3- 8
3.4.4 Offset/gain setting .....	3- 8
3.4.5 Combinations of various functions .....	3- 8
3.5 I/O Signals to the Master Station .....	3-10
3.5.1 I/O signal list .....	3-10
3.5.2 Functions of the I/O signals .....	3-11
3.6 Remote Register .....	3-12
3.6.1 Allocation of the remote register .....	3-12
3.6.2 Digital value setting area for channels 1 through 4 .....	3-13
3.6.3 Analog output enable/prohibit channel .....	3-13
3.6.4 Set value checking code storage area for channels 1 through 4 .....	3-14
3.6.5 Error code .....	3-14



<b>4. SETUP AND PREPARATION BEFORE OPERATION</b>	<b>4- 1 to 4- 8</b>
--	---------------------

4.1 Precautions When Handling .....	4- 1
4.2 Name of Each Part.....	4- 2
4.3 Offset/Gain Setting.....	4- 4
4.4 Station Number Setting.....	4- 5
4.5 Facing Direction of the Module Installation .....	4- 5
4.6 Data link Cable Wiring .....	4- 6
4.6.1 CC-Link dedicated cable connections .....	4- 6
4.7 Wiring.....	4- 7
4.7.1 Precautions when wiring .....	4- 7
4.7.2 Wiring between the AJ65BT-64DAV/DAI and external devices .....	4- 7

<b>5. PROGRAMMING</b>	<b>5- 1 to 5-18</b>
-----------------------	---------------------

5.1 Programming Procedure.....	5- 1
5.2 Conditions of Program Example.....	5- 2
5.3 Program Example for Use of the QCPU (Q mode).....	5- 4
5.4 Program Example for Use of the QnACPU .....	5-10
5.5 Program Example for Use of the ACPU/QCPU (A mode) (dedicated instructions) .....	5-12
5.6 Program Example for Use of the ACPU/QCPU (A mode) (FROM/TO instructions) .....	5-16

<b>6. TROUBLESHOOTING</b>	<b>6- 1 to 6- 2</b>
---------------------------	---------------------

6.1 Error Code List .....	6- 1
6.2 Troubleshooting .....	6- 1
6.2.1 When a communication fault occurs between the master station and this module .....	6- 2

<b>APPENDIX</b>	<b>App- 1 to App- 2</b>
-----------------	-------------------------

Appendix 1 External Dimensions of the AJ65BT-64DAV .....	App- 1
Appendix 2 External Dimensions of the AJ65BT-64DAI.....	App- 2

## About this Manual

The following are manuals related to this product.  
Request for the manuals as needed according to the chart below.

### Related Manuals

Manual Name	Manual No. (Type code)
CC-Link System Master/Local Module Type AJ61BT11/A1SJ61BT11 User's Manual Describes the system configuration, performance specifications, functions, handling, wiring and troubleshooting of the AJ61BT11 and A1SJ61BT11. (Optionally available)	IB-66721 (13J872)
CC-Link System Master/Local Module Type AJ61QBT11/A1SJ61QBT11 User's Manual Describes the system configuration, performance specifications, functions, handling, wiring and troubleshooting of the AJ61QBT11 and A1SJ61QBT11. (Optionally available)	IB-66722 (13J873)
CC-Link System Master/Local Module User's Manual Describes the system configuration, performance specifications, functions, handling, wiring and troubleshooting of the QJ61BT11N. (Optionally available)	SH-080394E (13JR64)
MELSEC-L CC-Link System Master/Local Module User's Manual Describes the system configuration, Performance specifications, functions, handling, wiring and troubleshooting of the L26CPU-BT and LJ61BT11. (Optionally available)	SH-080895ENG (13JZ41)

### Compliance with the EMC and Low Voltage Directives

- (1) For programmable controller system  
To configure a system meeting the requirements of the EMC and Low Voltage Directives when incorporating the Mitsubishi programmable controller (EMC and Low Voltage Directives compliant) into other machinery or equipment, refer to the "EMC AND LOW VOLTAGE DIRECTIVES" chapter of the User's Manual for the CPU module used.  
The CE mark, indicating compliance with the EMC and Low Voltage Directives, is printed on the rating plate of the programmable controller.
- (2) For the product  
For the compliance of this product with the EMC and Low Voltage Directives, refer to the "CC-Link module" section in the "EMC AND LOW VOLTAGE DIRECTIVES" chapter of the User's Manual for the CPU module used.

MEMO

---

---

---

---

---

---

---

---

---

---

---

---

---

---

---

---

---

---

---

---

---

---

---

---

---

---

---

---

---

---

---

# 1. OVERVIEW

1

This user's manual describes the specification and handling of AJ65BT-64DAV digital analog voltage conversion module (abbreviated as AJ65BT-64DAV from here on) and AJ65BT-64DAI digital analog current conversion module (abbreviated as AJ65BT-64DAI from here on), which is used as the remote device station for the CC-Link system.

(1) AJ65BT-64DAV

This is a module which converts the digital values (16-bit encoded binary value) set in the programmable controller CPU to analog values (-10V to 0V to 10V voltage), and performs an external output to four channels.

(2) AJ65BT-64DAI

This is a module which converts the digital values (16-bit encoded binary value) set in the programmable controller CPU to analog values (4mA to 20mA current), and performs an external output to four channels.

In this manual, the name which refers to both AJ65BT-64DAV and AJ65BT-64DAI is abbreviated as "AJ65BT-64DAV/DAI."

## 1.1 Features

---

The AJ65BT-64DAV/DAI has the following features:

(1) One module can provide four channels of D/A conversion.

The AJ65BT-64DAV/DAI can produce output of analog values (voltage/current) to four external devices.

(2) The analog-output enable/prohibit setting is possible for each channel.

The sequence program can specify whether to enable or prohibit analog output to the external devices after the D/A conversion for each channel.

Analog output from the channel where the analog output is prohibited will be 0V or 0mA.

(3) You can make the analog output hold/clear setting at a programmable controller CPU stop or link error occurrence (all channels batch).

Using the HOLD/CLR terminal, you can select whether to hold or clear the analog output at the instant the programmable controller CPU is set to a STOP status or a link error occurs.

(4) Offset and gain setting

When a fine I/O conversion characteristic is required, the offset and gain setting of each channel can be set without a volume control, enabling to modify the I/O conversion characteristic as desired.



## 2. SYSTEM CONFIGURATION

(1) Applicable master modules

For available master modules, visit the CC-Link Partner Associations (CLPA) website at:

<http://www.cc-link.org/>

2

**Remark**

Check the specifications of the master module before use.



## 3. SPECIFICATIONS

The general specifications, performance specifications, and I/O characteristics of the AJ65BT-64DAV/DAI are explained.

### 3.1 General Specification

The general specifications of the AJ65BT-64DAV/DAI are shown in Table 3.1.

Table 3.1 General specification

Item	Specification					
Usage ambient temperature	0 to 55°C					
Storage ambient temperature	-20 to 75°C					
Usage ambient humidity	10 to 90%RH, no condensation					
Storage ambient humidity	10 to 90%RH, no condensation					
Vibration durability	Conforming to JIS B 3502, IEC 61131-2	For intermittent vibration	Frequency	Acceleration	Amplitude	Number of sweeps
			5 to 9Hz	—	3.5mm (0.14 inches)	10 times in each X, Y, and Z direction
		9 to 150Hz	9.8m/s <sup>2</sup>	—		
		For continuous vibration	5 to 9Hz	—	1.75mm (0.069 inches)	—
9 to 150Hz	4.9m/s <sup>2</sup>	—				
Shock durability	Conforming to JIS B 3502, IEC 61131-2 (147m/s <sup>2</sup> , 3 times each in XYZ directions)					
Usage environment	No corrosive gas					
Usage height * <sup>1</sup>	Less than 2000 m (Less than 6562 ft.)					
Installation area	Within the control board					
Over-voltage category * <sup>2</sup>	Less than II					
Pollution rate * <sup>3</sup>	Less than 2					

#### Remark

- \*1 Do not operate or store the programmable controller in the environment where the pressure applied is equal to greater than the atmospheric pressure at the altitude of 0m. Doing so may cause a malfunction. Please consult our branch office when the programmable controller is to be operated under pressure.
- \*2 Indicates the location where the device is connected from the public cable network to the device structure wiring area. Category II applies to the devices to which the power is supplied from a fixed equipment. Surge withstand voltage for devices with up to 300V of rated voltage is 2500V.
- \*3 This is an index which indicates the degree of conductive object generation in the environment where the device is used. Level 2 is an environment where only nonconductive objects are formed with some chances of temporary conductivity generation due to occasional condensation.



## 3.2 Performance Specification

The performance specification of the AJ65BT-64DAV/DAI is shown Table 3.2:

Table 3.2 Performance specification

Item	Specification			
	AJ65BT-64DAV		AJ65BT-64DAI	
Digital input value	16-bit encoded binary (valid bit: 12 bits)			
	-2048 to 2047		0 to 4095	
Analog conversion value	Voltage: -10 to 10VDC (External load resistance: 2kΩ to 1MΩ)		Current: 4 to 20mADC (External load resistance: 0 to 600Ω)	
I/O characteristics	Digital input value	Analog conversion value	Digital input value	Analog conversion value
	2000	10V	4000	20mA
	1000	5V	2000	12mA
	0	0V	0	4mA
	-1000	-5V		
	-2000	-10V		
Maximum resolution *1	5mV		4μA	
Total accuracy *2 (accuracy for the maximum value)	± 1% (± 100mV)		± 1% (±200μA)	
Maximum conversion speed *3	Max. 1ms per channel (4ms per 4 channels)			
Output short-circuit protection	Yes			
Insulation system	Across output channels: Non-insulated Across external supply power and analog output: Transformer insulated			
Analog output points	4 channels per module			
Offset/gain adjustment	Yes (user setting or factory setting)			
CC-Link station type	Remote device station			
Number of occupied stations	2 stations			
Connector terminal block	27-point terminal block (M3.5 × 7 screws)			
Supported cable size	0.75 to 2.00mm <sup>2</sup>			
Supported solderless terminal	RAV 1.25-3.5 (according to JIS C 2805), RAV 2-3.5			
Module installation screw	M4 x 0.7mm x 16mm or larger screw (tightening torque 0.78 to 1.18N·m) Installable with the DIN rail.			
Supported DIN rail	TH35-7.5Fe, TH35-7.5Al, TH35-15Fe (conforming to JIS C 2812)			
External supply power	24V DC (20.4V DC to 26.4V DC)			
	Inrush current: 1.5A, within 0.67ms		Inrush current: 3.2A, within 0.43ms	
	Current consumption:0.18A (at 24VDC)		Current consumption:0.27A (at 24VDC)	
Noise resistance	Noise voltage: 500Vp-p Measured using a noise simulator with 1μs of noise amplitude and 25 to 60Hz of noise frequency.			
Dielectric withstand voltage	Power and communication systems batch-Analog output batch, 500VAC, one minute			
Insulation resistor	Power and communication systems batch-Analog output batch, 500VDC 10MΩ or more at the insulation resistance tester			
Weight	0.4kg		0.4kg	

\*1 Maximum resolution of analog value  
 The maximum resolution of analog value means the variation of analog value when the digital value changes for "1".

\*2 Total accuracy  
 The total accuracy is the accuracy of the maximum analog output value.

① The overall accuracy of the AJ65BT-64 DAV is the accuracy for 10V.

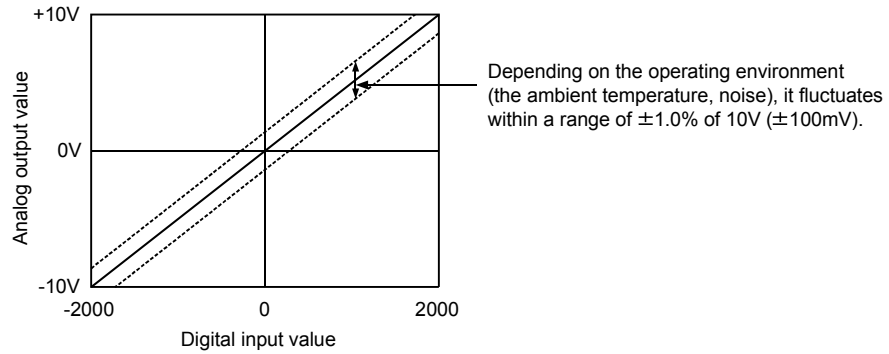

② The overall accuracy of the AJ65BT-64 DAI is the accuracy for 20mA.

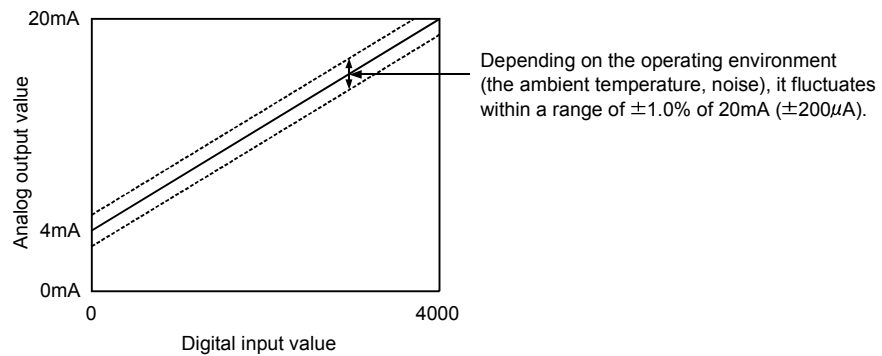

\*3 Maximum conversion speed  
 The maximum conversion speed means the time required to read the digital value written in the buffer memory, execute the D/A conversion, and output the specified analog value. It takes the longest (1ms) to produce the maximum analog output value when the current output is the minimum, and to produce the minimum analog output value when the current output is the maximum.

### 3.3 I/O Conversion Characteristics

The I/O conversion characteristics of the AJ65BT-64DAV/DAI are explained.

#### 3.3.1 Offset value and gain value

- (1) Offset value  
This is an analog value (voltage or current value) produced by the AJ65BT-64DAV/DAI when the digital value set by the programmable controller CPU is "0".
- (2) Gain value  
This is an analog value (voltage or current value) produced by the AJ65BT-64DAV/DAI when the digital value set by the programmable controller CPU is "2000" for AJ65BT-64DAV, and "4000" for AJ65BT-64DAI.
- (3) The factory-set offset and gain values are as follows:

	AJ65BT-64DAV	AJ65BT-64DAI
Offset value	0V	4mA
Gain value	10V	20mA

- (4) The offset value and gain value can be set separately for each channel in the test mode.

#### 3.3.2 I/O conversion characteristics

- (1) When AJ65BT-64DAV is used:

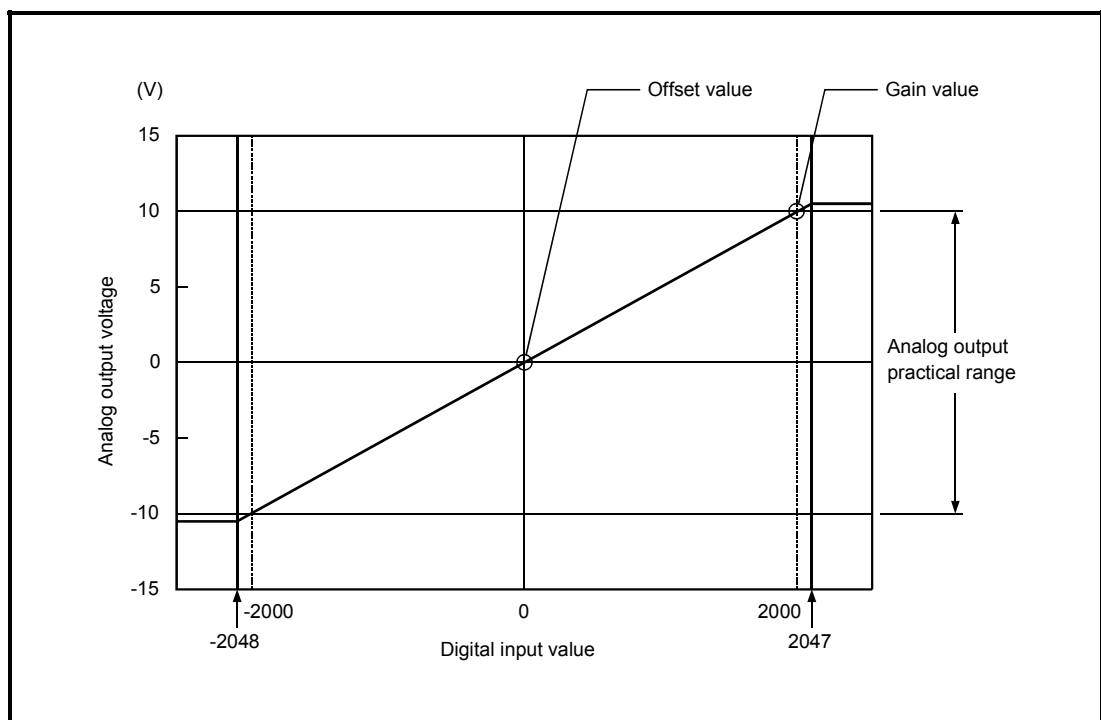

Figure 3.1 I/O conversion characteristics of the AJ65BT-64DAV

- ① How to calculate the analog output value:  
The resolution of AJ65BT-64DAV can be set arbitrarily by modifying the settings of the offset value and gain value.  
How to calculate the analog value resolution and the analog output value for a given digital input value when the settings of the offset value and gain value are changed is shown next.

$$(\text{Analog output}) = (\text{Analog resolution}) \times (\text{Digital input value}) + (\text{Offset value})$$

$$(\text{Analog resolution}) = \frac{(\text{Gain value}) - (\text{Offset value})}{2000}$$

- ② The following graph shows the I/O characteristics when the offset and gain values of the AJ65BT-64DAV are changed:

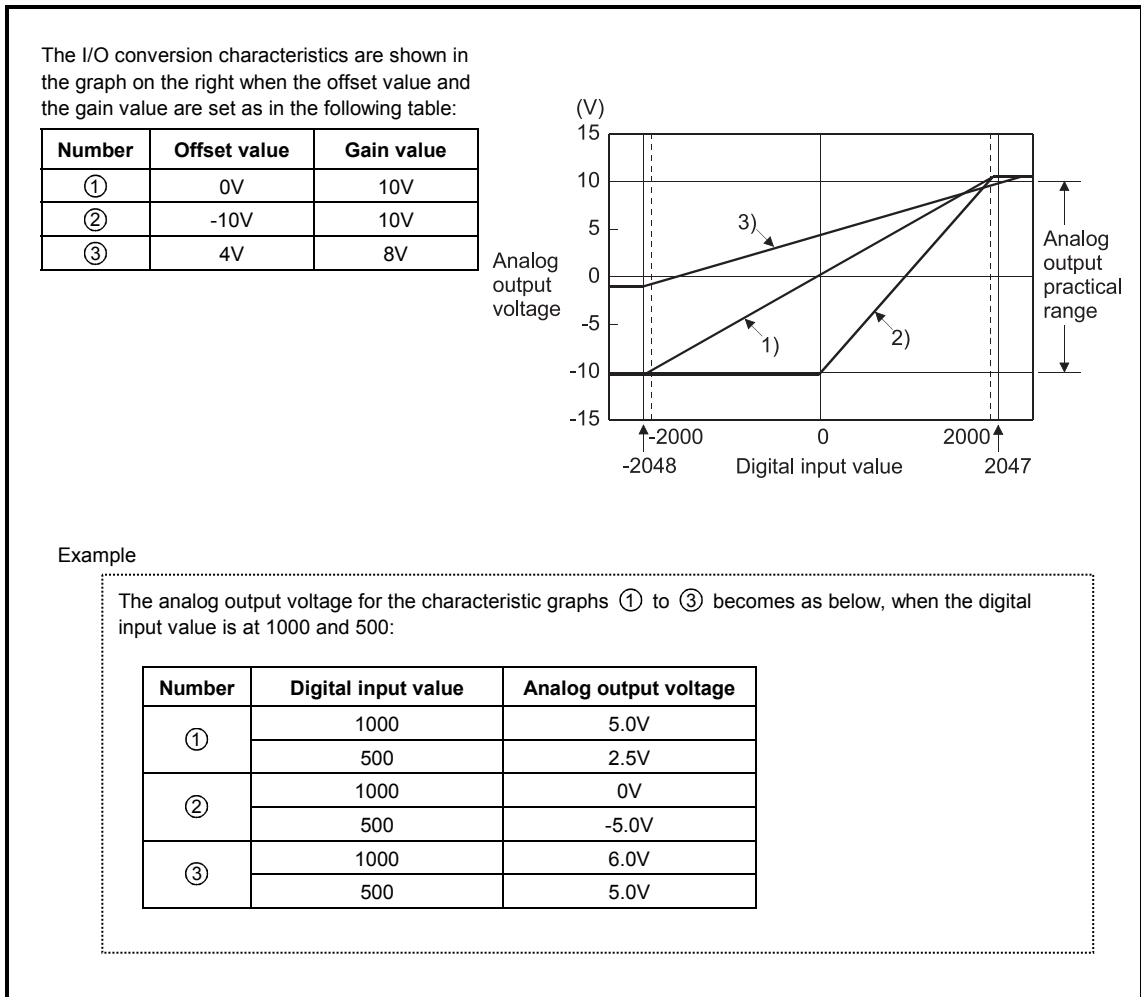

Figure 3.2 I/O conversion characteristics of AJ65BT-64DAV

(2) When AJ65BT-64DAI is used:

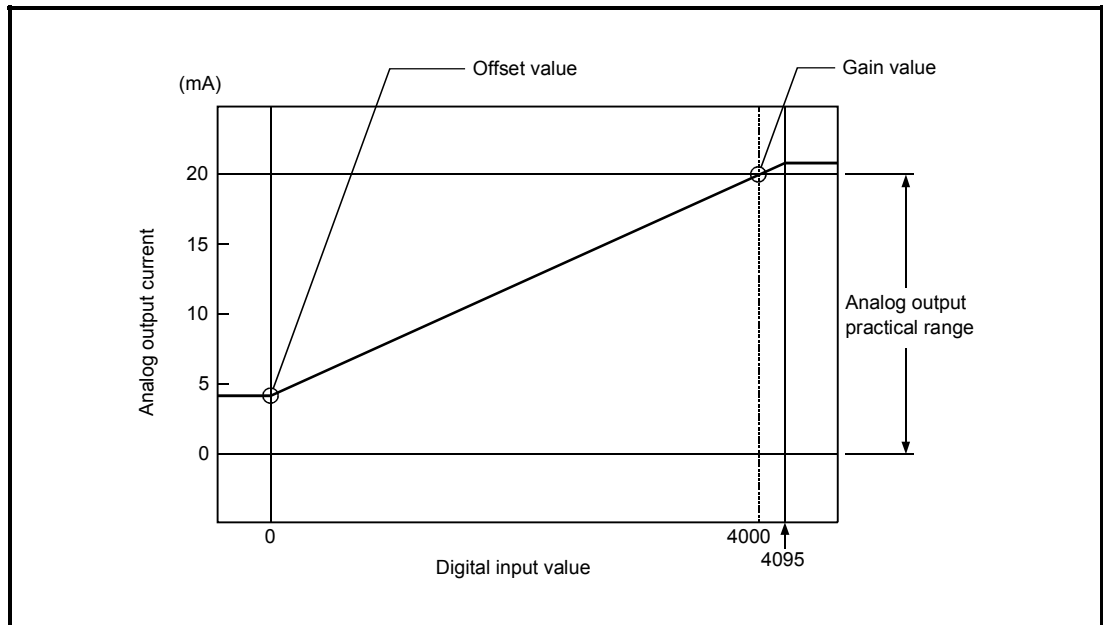

Figure 3.3 I/O conversion characteristics of AJ65BT-64DAI

- ① How to calculate the analog value  
 The resolution of AJ65BT-64DAI can be set arbitrarily by modifying the settings of the offset value and gain value.  
 How to calculate the analog value resolution and the analog output value for a given digital input value when the settings of the offset value and gain value are changed is shown.

$$(\text{Analog output}) = (\text{Analog resolution}) \times (\text{Digital input value}) + (\text{Offset value})$$

$$(\text{Analog resolution}) = \frac{(\text{Gain value}) - (\text{Offset value})}{4000}$$

- ② The following graph shows the I/O characteristic when the offset and gain values of the AJ65BT-64DAI are changed:

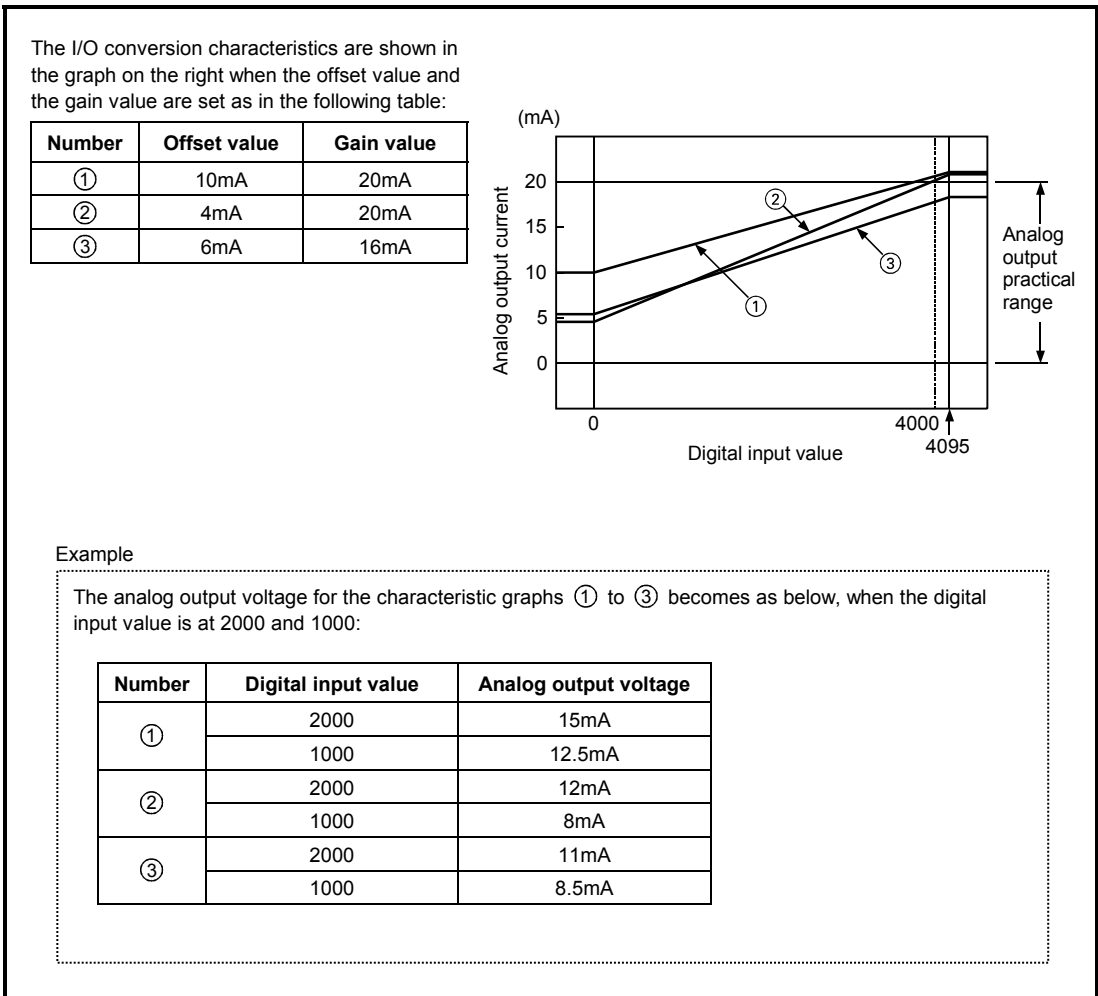

Figure 3.4 I/O conversion characteristics of AJ65BT-64DAI

## 3.4 Various Functions to Control the Analog Output

---

Various functions to control the analog output of the AJ65BT-64DAV/DAI are explained.

### 3.4.1 Function to specify hold or clear of the analog output when the programmable controller CPU is in the STOP status (HOLD/CLEAR setting)

---

Using this function, the HLD/CLR terminal on the module front panel can be used to set whether to retain or clear (i.e. to output the offset) the analog output value immediately before the programmable controller CPU enters the STOP status or before the AJ65BT-64DAV/DAI stops the D/A conversion due to an error. All channels are set simultaneously. (Including a time when link communications are shut off)

### 3.4.2 Function to specify executing or not executing the D/A conversion processing (Analog output enable/disable flag)

---

Using this function, whether to output the D/A conversion value or the offset value can be selected for each channel by turning on or off the Analog output enable/disable flag from the programmable controller program.

However, the D/A conversion time (conversion speed) is constant regardless of the setting of the Analog output enable/disable flag.

ON: D/A conversion value    OFF: Offset value

### 3.4.3 Function to specify enabling or prohibiting of the analog value external output (Analog output enable/prohibit setting)

---

Using this function, whether to enable or prohibit the external output of the analog signal can be specified for each channel by writing "0" or "1" to the remote register's address from the programmable controller program.

1: 0V/0mA    0: D/A conversion value or offset value

### 3.4.4 Offset/gain setting

---

When a fine I/O conversion characteristic is required, the I/O conversion characteristics can be modified arbitrarily by setting the offset and gain of each channel without a volume control, after entering the test mode by short-circuiting the test mode terminal. When it is not necessary, turning on the RYn4, which is the I/O signal to the master station, selects the factory-configured offset and gain values.

Factory-configured values:

AJ65BT-64DAV..... Offset value 0V, Gain value 10V

AJ65BT-64DAI..... Offset value 4mA, Gain value 20mA

### 3.4.5 Combinations of various functions

---

By combining the functions explained above, the analog output when the programmable controller CPU is in the RUN status and when a module error occurs can be set as desired, as shown in Table 3.3.

Select each function depending on the analog output status of your choice.

Table 3.3 Analog output status combination list

Setting combination Execution status	HOLD/CLEAR setting	CLEAR				HOLD	
	Analog output enable signal	Enable (on)		Prohibit (off)		Enable (on)/Prohibit (off)	
	Analog output enable/disable flag	Enable (0)	Prohibit (1)	Enable (0)	Prohibit (1)	Enable (0)	Prohibit (1)
Analog output status when the programmable controller CPU is in the RUN status		Output of the analog value after D/A conversion from the digital value specified by the programmable controller CPU	0V/0mA	Offset value	0V/0mA	Output of the analog value after D/A conversion from the digital value specified by the programmable controller CPU	0V/0mA
Analog output status when the programmable controller CPU is in the STOP status		Offset value	0V/0mA	Offset value	0V/0mA	Analog value before the programmable controller CPU stop is retained.	0V/0mA
Analog output status when the programmable controller CPU is in the error status		Offset value	0V/0mA	Offset value	0V/0mA	Analog value before the CPU error is retained.	0V/0mA
Analog output status when an error has occurred in the AJ65BT-64DAV/DAI		Output of the maximum or minimum analog value	0V/0mA	Offset value	0V/0mA	Output of the maximum or minimum analog value	0V/0mA
Analog output status when a WDT error (*) has occurred in the AJ65BT-64DAV/DAI		0V/0mA					
Analog output status when the L.RUN LED is turned off (when link communications are shut off)		Offset value	0V/0mA	Offset value	0V/0mA	Analog value before the LINK ERR is retained.	0V/0mA
Analog output status after reset		Output of the analog value after D/A conversion from the digital value specified by the programmable controller CPU	0V/0mA	Offset value	0V/0mA	Output of the analog value after D/A conversion from the digital value specified by the programmable controller CPU	0V/0mA

(\*) WDT error .....indicates the abnormal operation time by the programmable controller. The elapsed time for one scan by the program is monitored, and a WDT error results when it does not finish within the scheduled time.



### 3.5 I/O Signals to the Master Station

Assignment of the I/O signals and function of each signal are explained.

#### 3.5.1 I/O signal list

The AJ65BT-64DAV/DAI uses 32 input points and 32 output points for exchanging signals with the master station.\*1 The allocation of the I/O signals and the name of each signal are listed in Table 3.4. An RX device indicates an input signal from the AJ65BT-64DAV/DAI to the master module, and a RY device indicates an output signal from the master module to the AJ65BT-64DAV/DAI.

Table 3.4 I/O signals

Signal direction: AJ65BT-64DAV/DAI→Master		Signal direction: Master→AJ65BT-64DAV/DAI	
Device No.	Signal name	Device No.	Signal name
RXn0  to  RXnF	Unusable	RYn0	CH.1 Analog output enable/disable flag
		RYn1	CH.2 Analog output enable/disable flag
		RYn2	CH.3 Analog output enable/disable flag
		RYn3	CH.4 Analog output enable/disable flag
		RYn4	Offset/gain value selection
		RYn5 to RYnF	Unusable
RX (n+1) 0 to RX (n+1) 7	Unusable	RY (n+1) 0 to RY (n+1) 7	Unusable
RX (n+1) 8	Initial data processing request flag	RY (n+1) 8	Initial data processing complete flag
RX (n+1) 9	Initial data setting complete flag	RY (n+1) 9	Initial data setting request flag
RX (n+1) A	Error status flag	RY (n+1) A	Error reset request flag
RX (n+1) B	Remote READY	RY (n+1) B to RY (n+3) F	Unusable
RX (n+1) C to RX (n+3) F	Unusable		

n: The address allocated to the master station in the station number setting

\*1 Although the number of occupied stations for the AJ65BT-64DAV/DAI is 2, inputs, RX(n+2) 0 to RX(n+3)F, are not used.

However, devices for inputs, RX(n+2) 0 to RX(n+3)F, and outputs, RY(n+2) 0 to RY(n+3) F, are reserved in the master module or CPU module. When creating a program, pay attention to device allocation.

Point	
	If a device not allowed to use is turned on/off from the sequence program, the function of the AJ65BT-64DAV/DAI is not guaranteed.

3.5.2 Functions of the I/O signals

Functions of the I/O signals of the AJ65BT-64DAV/DAI are shown in Table 3.5.

Table 3.5 Descriptions of the I/O signals

Device number	Signal Name	Description
RX (n+1) 8	Initial data processing request flag	After the power is turned on or after the hardware reset, the initial data processing request flag is turned on by the AJ65BT-64DAV/DAI in order to request the initial data setting. It is turned off when the initial data setting is complete (i.e. initial data processing complete flag RY(n+1)8 is turned on).
RX (n+1) 9	Initial data setting complete flag	When there is an initial data setting request (i.e. RY(n+1)9 is turned on), it is turned on by the initial data setting completion. When the initial data setting request flag is turned off after the initial data setting completion, the initial data setting complete flag is also turned off.
RX (n+1) A	Error status flag	This is turned on when an error other than the WDT error occurs on the AJ65BT-64DAV/DAI.
RX (n+1) B	Remote READY	This is turned on when the initial data setting is complete and the AJ65BT-64DAV/DAI is in the READY status, after the power is turned on or after the hardware reset. It is turned off during the test mode. (This is used to interlock the read and write from the master module.)
RYn0 to RYn3	CH.□ analog output enable/disable flag	These are the analog value output enable signals for channels 1 through 4. The analog output value from the corresponding channel is enabled when turned on. Turn it off to prohibit the output of the analog value.
RYn4	Offset/gain value selection	"User settings" or "factory settings" of the offset and gain values are selected by switching the RYn4. To select the factory setting, keep the RYn4 set to on.
RY (n+1) 8	Initial data processing complete flag	After the power is turned on or after the hardware reset, the initial data processing is executed by the initial data processing request, and this flag is turned on after the processing is completed.
RY (n+1) 9	Initial data processing request flag	Turn this on to set or modify the initial data.
RY (n+1) A	Error reset request flag	When the error reset request flag (RY(n+1)A) is turned on, the error status flag (RX(n+1)A) is turned off and the error code of the remote register write area is cleared (0000H).

The ON and OFF timing of each flag for the initial data processing request, processing complete, setting complete, and the setting request by the AJ65BT-64DAV/DAI:

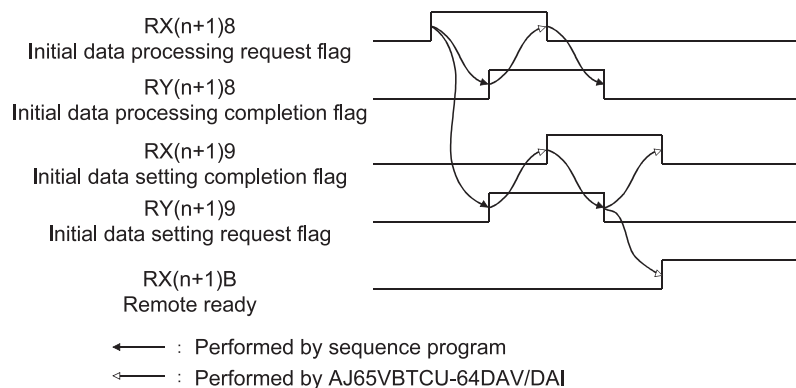

## 3.6 Remote Register

The AJ65BT-64DAV/DAI has a remote register (does not have backup) for data communication with the master module. The remote register allocation and data structure are described below.

### 3.6.1 Allocation of the remote register

The allocation of the remote register is shown in Table 3.6.

Table 3.6 Allocation of the remote register

	Address	Description	Initial value	Reference section
Write area (M→R)	RWwm	CH.1 digital value setting	0	Section 3.6.2
	RWwm+1	CH.2 digital value setting	0	
	RWwm+2	CH.3 digital value setting	0	
	RWwm+3	CH.4 digital value setting	0	
	RWwm+4	Analog output enable/disable setting	0	Section 3.6.3
	RWwm+5	Unusable		
	RWwm+6			
	RWwm+7			
Read area (R→M)	RWrn	CH.1 set value check code	0	Section 3.6.4
	RWrn+1	CH.2 set value check code	0	
	RWrn+2	CH.3 set value check code	0	
	RWrn+3	CH.4 set value check code	0	
	RWrn+4	Error code	0	Section 3.6.5
	RWrn+5	Unusable		
	RWrn+6			
	RWrn+7			

m, n: The address set for the master station in the station number setting.

Point
Do not execute read or write to the remote register that is not allowed to use. When a read or write is executed, the function of the AJ65BT-64DAV/DAI is not guaranteed.

**3.6.2 Digital value setting area for channels 1 through 4**

- (1) This area is used to write the digital value for the D/A conversion from the programmable controller CPU.
- (2) The digital values at all channels become "0" in the following conditions:
  - (a) After the power is turned on, when the remote READY (RX(n+1)B) is turned on.
  - (b) After the reset of the programmable controller CPU, when the remote READY (RX(n+1)B) is turned on.
- (3) The digital value can be set as 16-bit signed binary data and within the available setting range of the digital value resolution.  
 If a value beyond the range of the digital value resolution is set, the data in Table 3.7 is applied for the D/A conversion.  
 In addition, the checking code is stored in the set value checking code storage area (addresses from RWrn to RWrn+3).

Table 3.7 Available setting range of the digital value

Model Name	Available setting range	Digital value for the D/A conversion when the value beyond the range is set
AJ65BT-64DAV	-2048 to 2047 (Practical range: -2000 to 2000)	2048 or higher: 2047 -2049 or lower: -2048
AJ65BT-64DAI	0 to 4095 (Practical range: 0 to 4000)	4096 or higher: 4095 -1 or lower: 0

**3.6.3 Analog output enable/prohibit channel**

- (1) Enable or prohibit of the external output of the analog value from each channel is set in this area.
- (2) Output is prohibited at all channels in the following conditions:
  - (a) When the power is turned on.
  - (b) When the power is reset.
 Note that when initial data processing is finished, (module ready turns on, and) the output is enabled at all channels with the default values of 0.
- (3) Enable/prohibit of the external output is set to 0 or 1 for each channel.
  - (a) 0 ..... Enabled
  - (b) 1 ..... Prohibited
- (4) Configuration of the output enable/prohibit area for each channel is as follows:

Configuration of the output enable/prohibit area for each channel

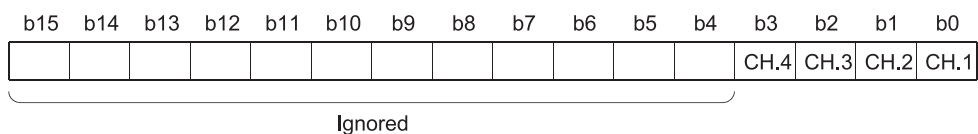

**3.6.4 Set value checking code storage area for channels 1 through 4**

This area is used to check if the digital value is within or out of the setting range. One of the following checking codes is stored when the digital value lower or higher than the setting range is set.

Check code list

Check code	Description
000FH	A digital value which exceeds the setting range was set.
00F0H	A digital value which is below the setting range was set.
00FFH	Both a digital value below the setting range and digital value exceeding the setting range were set. For example, the 00FFH check code is stored if a digital value exceeding the valid range is written, and then, without the check code being reset, a digital value that falls short of the valid range is written.

- (1) The check code once stored is not reset even if the set value is set to within the valid setting allowed range.
- (2) The storage area or the set value check code is reset by turning on the error reset request flag (RY (n+1) A).

**3.6.5 Error code**

- (1) If an error occurs when starting the module or writing data to the AJ65BT-64DAV/DAI (the RUN LED flashes), the following error code is stored in the error code (RWm+4) in the AJ65BT-64DAV/DAI remote register.

Error code list

Error code	Error description	Processing
11□	The set digital value is outside the setting range. The □ indicates the channel number where the error occurred.	Correct the digital value to within the setting range.
999	The offset/gain setting values stored in E <sup>2</sup> PROM became faulty.	Power-cycle the AJ65BT-64DAV/DAI again. If this recurs, the module may be faulty. Consult your local servicing company, dealer or our branch office.

The □ indicates the channel number where the error occurred.

- (2) When multiple errors occurred, the error code of the first error is stored, but the other errors are not stored.
- (3) The error code reset is performed by turning on the error reset request flag (RY (n+1) A). When the error code is "999", however, it cannot be reset because the hardware of the module is faulty.

# 4. SETUP AND PREPARATION BEFORE OPERATION

## 4.1 Precautions When Handling

The precautions when handling the AJ65BT-64DAV/DAI are described below:

 **CAUTION**

- Do not touch any terminal while power is on.  
Doing so may cause malfunction.
- Be sure there are no foreign substances such as sawdust or wiring debris inside the module.  
Such debris could cause fires, damage, or erroneous operation.
- Do not disassemble or modify the modules.  
Doing so may cause failure, malfunction, injury, or a fire.
- Do not directly touch the module's conductive parts or electronic components.  
Touching the conductive parts could cause an operation failure or give damage to the module.
- Do not drop or apply strong shock to the module.  
Doing so may damage the module.
- Do not remove the module print board from the case.  
This may cause breakdowns.
- Tighten the terminal screws with the specified torque.  
If the terminal screws are loose, it could result in short circuits, fire, or erroneous operation.
- When disposing of this product, treat it as industrial waste.
- If the terminal screws are loose, it could result in short circuits, fire, or erroneous operation.  
Using this programmable controller in an environment outside the range of the general specifications could result in electric shock, fire, erroneous operation, and damage to or deterioration of the product.
- For protection of the switches, do not remove the cushioning material before installation.
- Securely fix the module with a DIN rail or mounting screws. Tighten the screws within the specified torque range.  
Undertightening can cause drop of the screw, short circuit, or malfunction.  
Overtightening can damage the screw and/or module, resulting in drop, short circuit, or malfunction.
- Be sure to shut off all phases of the external power supply used by the system before mounting or dismounting the module to or from the panel.  
Not doing so could result in damage to the product.
- Before touching the module, always touch grounded metal, etc. to discharge static electricity from human body.  
Failure to do so can cause the module to fail or malfunction.

(1) Tighten the screws such as module installation screws with the following torque :

Screw location	Tightening torque range
Module installation screw (M4 screw)	0.78 to 1.18 N·m
Terminal block terminal screw (M3.5 screw)	0.59 to 0.88 N·m
Terminal block installation screw (M4 screw)	0.78 to 1.18 N·m

- (2) When using the DIN rail adapter, install the DIN rail by making sure of the following:
- (a) Applicable DIN rail models (conforming to JIS C 2812)
    - TH35-7.5Fe
    - TH35-7.5Al
    - TH35-15Fe
  - (b) DIN rail installation screw interval  
When installing the DIN rail, tighten the screws with less than 200mm (7.87 inch) pitches.
- (3) Refer to the Master Module user's manual for the name, specification, and manufacturers of supported cables for the use with AJ65BT-64DAV/DAI.

4.2 Name of Each Part

The name of each part in the AJ65BT-64DAV/DAI is described.

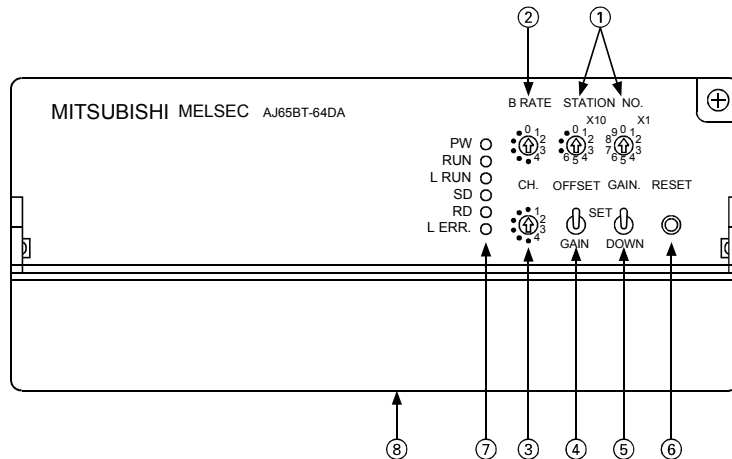

Number	Name	Description												
①	Station number setting switch	<div style="display: flex; align-items: center;"> <div style="margin-right: 10px;"> <span>⬇️x10</span> <span>⬇️x1</span> </div> <div>                     The AJ65BT-64DAV/DAI station number is set within the range 1 to 63. (Factory shipment setting : 00)                 </div> </div>												
②	B RATE (Transfer baud rate) setup switch	<table border="1" style="width: 100%; border-collapse: collapse; text-align: center;"> <thead> <tr> <th>Setting number</th> <th>Transfer baud rate</th> </tr> </thead> <tbody> <tr> <td>0</td> <td>156kbps(Factory shipment setting)</td> </tr> <tr> <td>1</td> <td>625kbps</td> </tr> <tr> <td>2</td> <td>2.5Mbps</td> </tr> <tr> <td>3</td> <td>5Mbps</td> </tr> <tr> <td>4</td> <td>10Mbps</td> </tr> </tbody> </table> <p>Unused (When a value other than 0 to 4 is set, L ERR. LED turns on, and results in a communication error.)</p>	Setting number	Transfer baud rate	0	156kbps(Factory shipment setting)	1	625kbps	2	2.5Mbps	3	5Mbps	4	10Mbps
Setting number	Transfer baud rate													
0	156kbps(Factory shipment setting)													
1	625kbps													
2	2.5Mbps													
3	5Mbps													
4	10Mbps													
③	CH. (CHANNEL) selection switch	Select the channel to perform offset adjustment or gain adjustment. (Positions other than 1 to 4 are not processed.)												
④	OFFSET/GAIN (Offset/gain) setting switch	The switch to set the offset/gain values during test mode. (1) OFFSET position : Calibration mode for the offset value (2) GAIN position : Calibration mode for gain value (3) SET position : When the switch is set from the OFFSET/GAIN position, which are modes to record offset/gain value to the SET position, to the SET position, the offset/gain value is recorded.												
⑤	UP/DOWN switch	The switch to adjust the analog output value for the offset/gain of the specified channel. The analog output value increases/decreases by turning on the UP/DOWN switch.												
⑥	RESET switch	Resets the H/W. Initializes the AJ65-BT-64DAV/DAI I/O signals, remote register, and operation processing. When the switch is turned on, AJ65BT-64DAV/DAI initial data processing request flag turns on.												

Number	Name	Description																																																																																																																
⑦	Operation status display LED	<table border="1"> <tr> <td data-bbox="518 320 735 387">PW LED</td> <td colspan="2" data-bbox="740 320 1414 387">On : When the power is on Off : When the power is shut off</td> </tr> <tr> <td data-bbox="518 394 735 533" rowspan="2">RUN LED</td> <td data-bbox="740 394 882 533">Normal mode</td> <td data-bbox="887 394 1414 533">On : Normal operation Flashing : Write data error Off : 24VDC power shutoff or watchdog timer error</td> </tr> <tr> <td data-bbox="740 539 882 831">Test mode</td> <td data-bbox="887 539 1414 831">Flashing : Flashes in 0.5 second intervals when the offset/gain setting switch is at OFFSET or GAIN. Flashes in 0.1 second intervals when exceeding the upper or lower limits of the allowable setting using the UP/DOWN switch. Off : When the offset/gain setting switch is at SET.</td> </tr> <tr> <td data-bbox="518 837 735 904">L RUN LED</td> <td colspan="2" data-bbox="740 837 1414 904">On : Normal communication Off : Communication interrupted (timeout error)</td> </tr> <tr> <td data-bbox="518 911 735 945">SD LED</td> <td colspan="2" data-bbox="740 911 1414 945">On : Data being transferred</td> </tr> <tr> <td data-bbox="518 952 735 985">RD LED</td> <td colspan="2" data-bbox="740 952 1414 985">On : Data being received</td> </tr> <tr> <td data-bbox="518 992 735 1332">L ERR. LED</td> <td colspan="2" data-bbox="740 992 1414 1332">On : When the baud rate or the station number setting is out of range. Flashing at regular intervals : When the baud rate or station number setting is changed after power-on or reset. Flashing at irregular intervals : When you forgot fitting the termination resistors or the module or CC-Link dedicated cable is affected by noise. Off : Normal communication</td> </tr> </table>	PW LED	On : When the power is on Off : When the power is shut off		RUN LED	Normal mode	On : Normal operation Flashing : Write data error Off : 24VDC power shutoff or watchdog timer error	Test mode	Flashing : Flashes in 0.5 second intervals when the offset/gain setting switch is at OFFSET or GAIN. Flashes in 0.1 second intervals when exceeding the upper or lower limits of the allowable setting using the UP/DOWN switch. Off : When the offset/gain setting switch is at SET.	L RUN LED	On : Normal communication Off : Communication interrupted (timeout error)		SD LED	On : Data being transferred		RD LED	On : Data being received		L ERR. LED	On : When the baud rate or the station number setting is out of range. Flashing at regular intervals : When the baud rate or station number setting is changed after power-on or reset. Flashing at irregular intervals : When you forgot fitting the termination resistors or the module or CC-Link dedicated cable is affected by noise. Off : Normal communication																																																																																													
PW LED	On : When the power is on Off : When the power is shut off																																																																																																																	
RUN LED	Normal mode	On : Normal operation Flashing : Write data error Off : 24VDC power shutoff or watchdog timer error																																																																																																																
	Test mode	Flashing : Flashes in 0.5 second intervals when the offset/gain setting switch is at OFFSET or GAIN. Flashes in 0.1 second intervals when exceeding the upper or lower limits of the allowable setting using the UP/DOWN switch. Off : When the offset/gain setting switch is at SET.																																																																																																																
L RUN LED	On : Normal communication Off : Communication interrupted (timeout error)																																																																																																																	
SD LED	On : Data being transferred																																																																																																																	
RD LED	On : Data being received																																																																																																																	
L ERR. LED	On : When the baud rate or the station number setting is out of range. Flashing at regular intervals : When the baud rate or station number setting is changed after power-on or reset. Flashing at irregular intervals : When you forgot fitting the termination resistors or the module or CC-Link dedicated cable is affected by noise. Off : Normal communication																																																																																																																	
⑧	Terminal block	<p>AJ65BT-64DAV</p> <table border="1"> <tr> <td>1</td><td>3</td><td>5</td><td>7</td><td>9</td><td>11</td><td>13</td><td>15</td><td>17</td><td>19</td><td>21</td><td>23</td><td>25</td><td>27</td> </tr> <tr> <td>DA</td><td>DG</td><td>+24V</td><td>24G</td><td>HLD/CLR</td><td>HLD/CLR</td><td>CH1/V+</td><td></td><td>CH2 V+</td><td></td><td>CH3 V+</td><td></td><td>CH4 V+</td><td></td> </tr> <tr> <td>2</td><td>4</td><td>6</td><td>8</td><td>10</td><td>12</td><td>14</td><td>16</td><td>18</td><td>20</td><td>22</td><td>24</td><td>26</td><td></td> </tr> <tr> <td>DB</td><td>SLD</td><td>(FG)</td><td>TEST</td><td>TEST</td><td></td><td>COM</td><td></td><td>COM</td><td></td><td>COM</td><td></td><td>COM</td><td></td> </tr> </table> <p>AJ65BT-64DAI</p> <table border="1"> <tr> <td>1</td><td>3</td><td>5</td><td>7</td><td>9</td><td>11</td><td>13</td><td>15</td><td>17</td><td>19</td><td>21</td><td>23</td><td>25</td><td>27</td> </tr> <tr> <td>DA</td><td>DG</td><td>+24V</td><td>24G</td><td>HLD/CLR</td><td>HLD/CLR</td><td>CH1/I+</td><td></td><td>CH2 I+</td><td></td><td>CH3 I+</td><td></td><td>CH4 I+</td><td></td> </tr> <tr> <td>2</td><td>4</td><td>6</td><td>8</td><td>10</td><td>12</td><td>14</td><td>16</td><td>18</td><td>20</td><td>22</td><td>24</td><td>26</td><td></td> </tr> <tr> <td>DB</td><td>SLD</td><td>(FG)</td><td>TEST</td><td>TEST</td><td></td><td>COM</td><td></td><td>COM</td><td></td><td>COM</td><td></td><td>COM</td><td></td> </tr> </table> <p>HLD/CLR setting terminal ....HOLD is set by shorting between terminals, and CLEAR is set by releasing.</p> <p>Test mode setting terminal ....By shorting between terminals, the system enters the test mode</p>	1	3	5	7	9	11	13	15	17	19	21	23	25	27	DA	DG	+24V	24G	HLD/CLR	HLD/CLR	CH1/V+		CH2 V+		CH3 V+		CH4 V+		2	4	6	8	10	12	14	16	18	20	22	24	26		DB	SLD	(FG)	TEST	TEST		COM		COM		COM		COM		1	3	5	7	9	11	13	15	17	19	21	23	25	27	DA	DG	+24V	24G	HLD/CLR	HLD/CLR	CH1/I+		CH2 I+		CH3 I+		CH4 I+		2	4	6	8	10	12	14	16	18	20	22	24	26		DB	SLD	(FG)	TEST	TEST		COM		COM		COM		COM	
1	3	5	7	9	11	13	15	17	19	21	23	25	27																																																																																																					
DA	DG	+24V	24G	HLD/CLR	HLD/CLR	CH1/V+		CH2 V+		CH3 V+		CH4 V+																																																																																																						
2	4	6	8	10	12	14	16	18	20	22	24	26																																																																																																						
DB	SLD	(FG)	TEST	TEST		COM		COM		COM		COM																																																																																																						
1	3	5	7	9	11	13	15	17	19	21	23	25	27																																																																																																					
DA	DG	+24V	24G	HLD/CLR	HLD/CLR	CH1/I+		CH2 I+		CH3 I+		CH4 I+																																																																																																						
2	4	6	8	10	12	14	16	18	20	22	24	26																																																																																																						
DB	SLD	(FG)	TEST	TEST		COM		COM		COM		COM																																																																																																						



### 4.3 Offset/Gain Setting

When changing the I/O conversion characteristics, follow the procedure below.

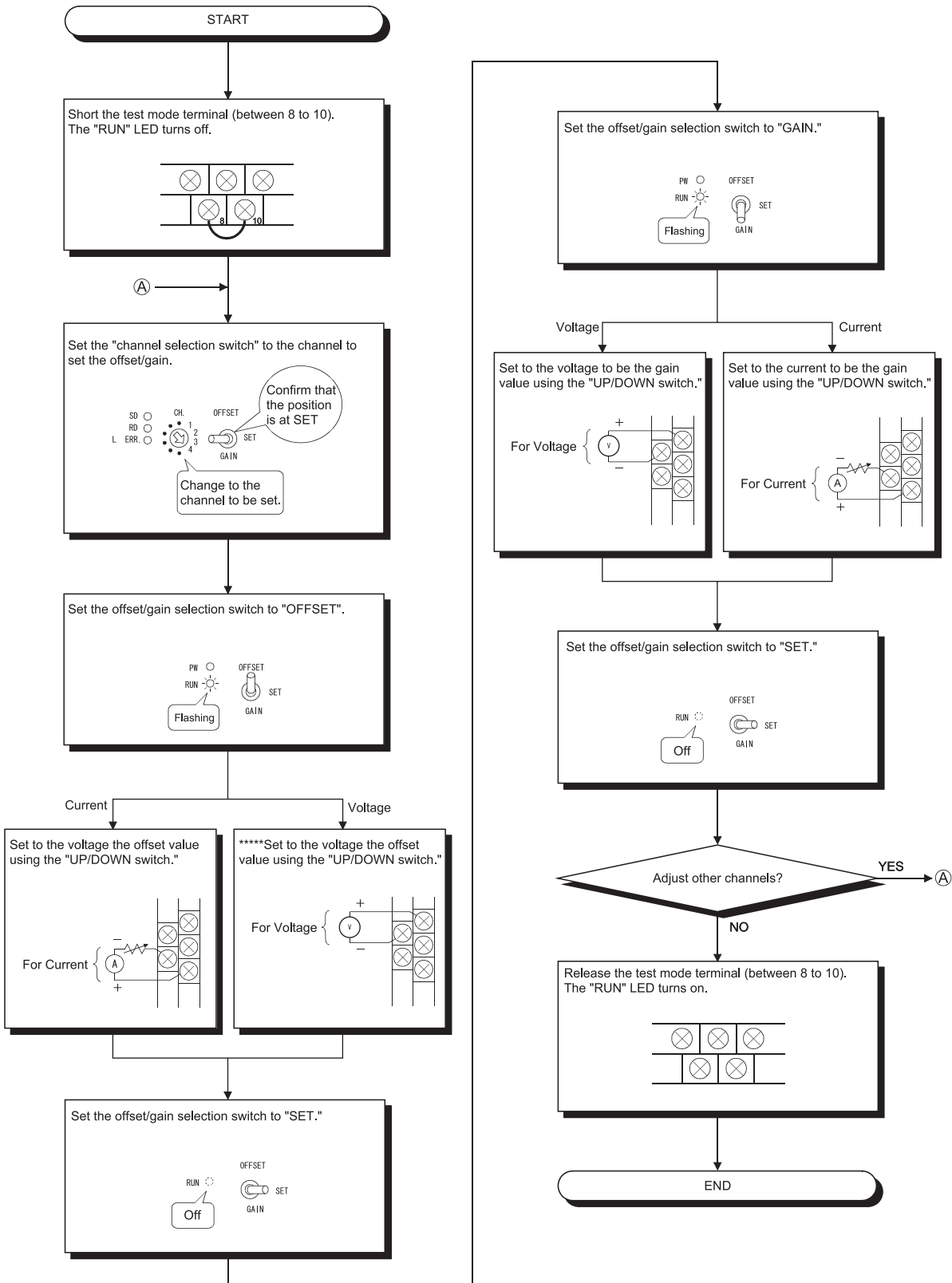

Point
(1) Set the offset and gain values in the actual usage state.
(2) The offset and gain values are stored in the AJ65BT-64DAV/DAI, and are not erased even the power supply is shut off.
(3) Perform the offset/gain setting when the programmable controller CPU is stopped. When in the test mode, D/A conversion is stopped for all channels, so use the remote READY signals as an interlock.
(4) Perform the offset/gain setting in the range from DC -10 to +10V or from 4 to +20mA. When the setting exceeds this range, the maximum resolution or total precision may not be in the range indicated in the performance specification.

#### 4.4 Station Number Setting

By the AJ65BT-64DAV/DAI station number setting, the addresses to store the control I/O signal data and read/write data are determined.

For details, refer to the user's manual of the master module used.

#### 4.5 Facing Direction of the Module Installation

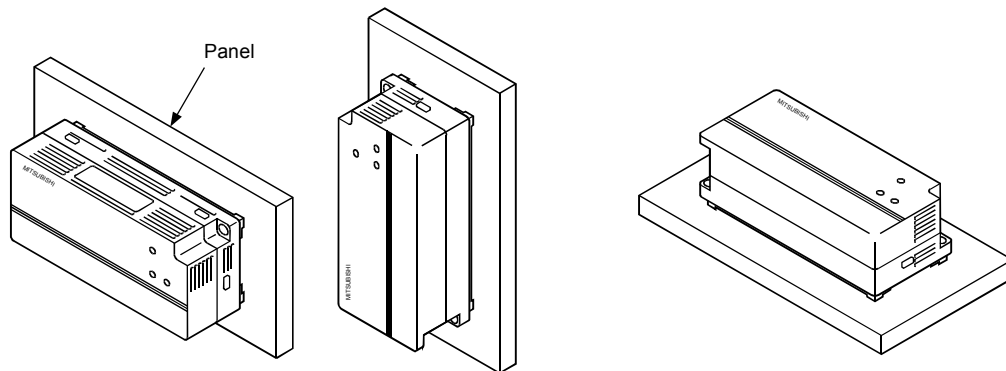

When the module is installed next to the panel

When the module is installed on the panel

## 4.6 Data link Cable Wiring

The wiring of the CC-Link dedicated cable which connects the AJ65BT-64DAV/DAI and the master module is described.

### 4.6.1 CC-Link dedicated cable connections

The CC-Link dedicated cable connections between the AJ65BT-64DAV/DAI and master module are as follows:

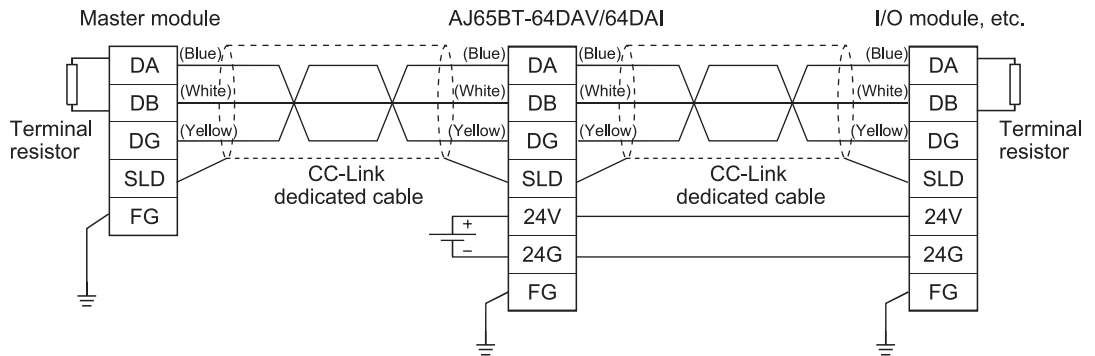

## 4.7 Wiring

Precautions when wiring the AJ65BT-64DAV/DAI and how to wire to the external devices are explained.

### 4.7.1 Precautions when wiring

To obtain maximum performance from the functions of AJ65BT-64DAV/DAI and improve the system reliability, an external wiring with high durability against noise is required.

The precautions performing external wiring for the AJ65BT-64DAV/DAI are shown below:

- (1) Use separate cables for the AC and AJ65BT-64DAV/DAI external input signals, in order not to be affected by the AC side surge or conductivity.
- (2) Do not bunch the control wires or load cables from other than the programmable controller with the wires to the module, or install them close to each other. Doing this makes the wiring easy to accept the noise, surge or induction effects.
- (3) Perform a one-point grounding for the shielded line or the shield of the shielded cable.

### 4.7.2 Wiring between the AJ65BT-64DAV/DAI and external devices

- (1) Wiring example of the AJ65BT-64DAV and external devices is shown in Figure 4.1.

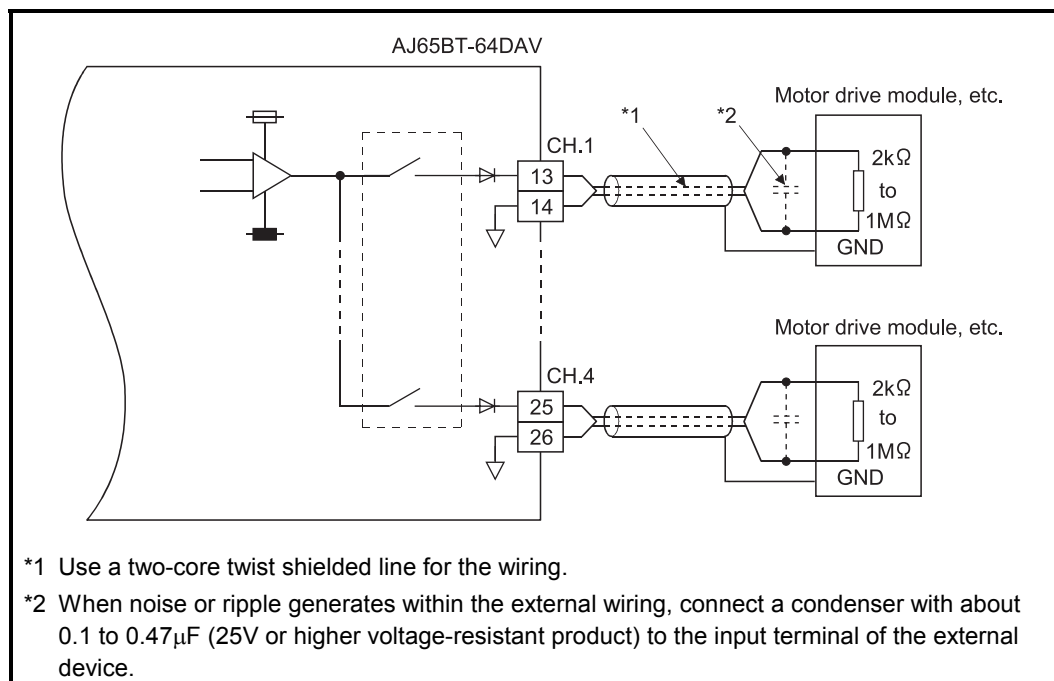

Figure 4.1 Wiring example of the AJ65BT-64DAV and external devices

(2) Wiring example of the AJ65BT-64DAI and external devices is shown in Figure 4.2.

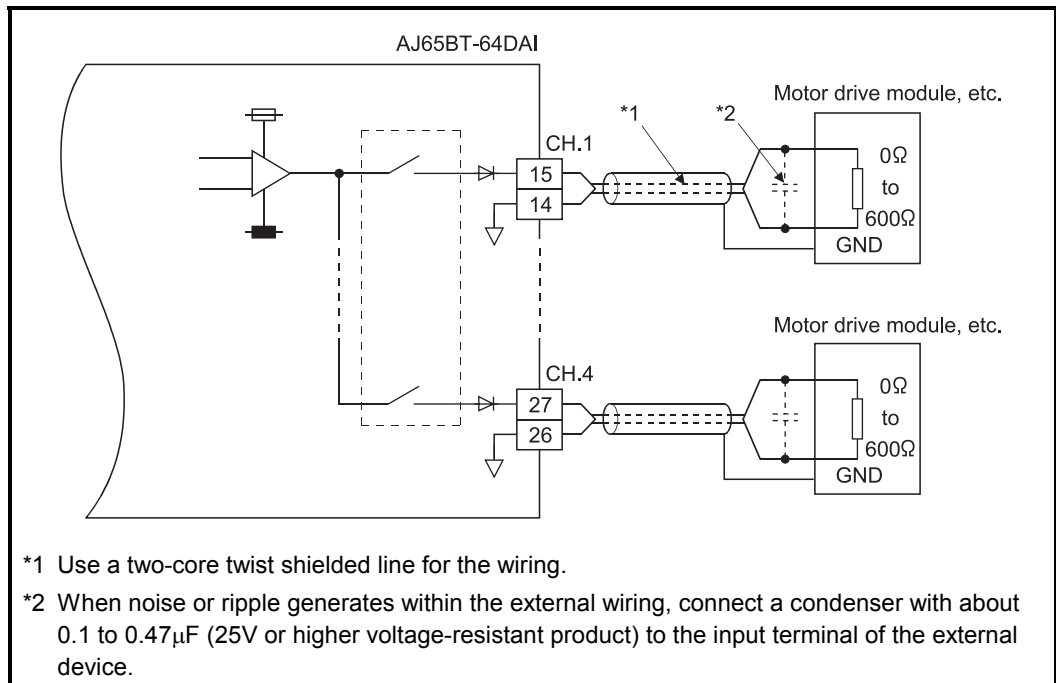

Figure 4.2 Wiring example of the AJ65BT-64DAI and external devices

**Remark**

Though you can perform the jumper wiring of the common line on the external device side, the commons are connected also inside this module.  
When wiring, be careful of sneak currents on the external device side.

## 5. PROGRAMMING

The programming procedure, basic read/write programs, and program examples for the AJ65BT-64DAV/DAI are described.

When applying any of the program examples introduced in this chapter to the actual system, verify the applicability and confirm that no problems will occur in the system control.

Refer to the user's manual of the master module used for the master module, to Section 3.6 for the remote registers, and to the AnSHCPU/AnACPU/AnUCPU/QCPU (A mode) Programming Manual (Dedicated Instructions) for details of the dedicated instructions.

### 5.1 Programming Procedure

Create programs for executing the digital-analog conversion of the AJ65BT-64DAV/DAI in the following procedure.

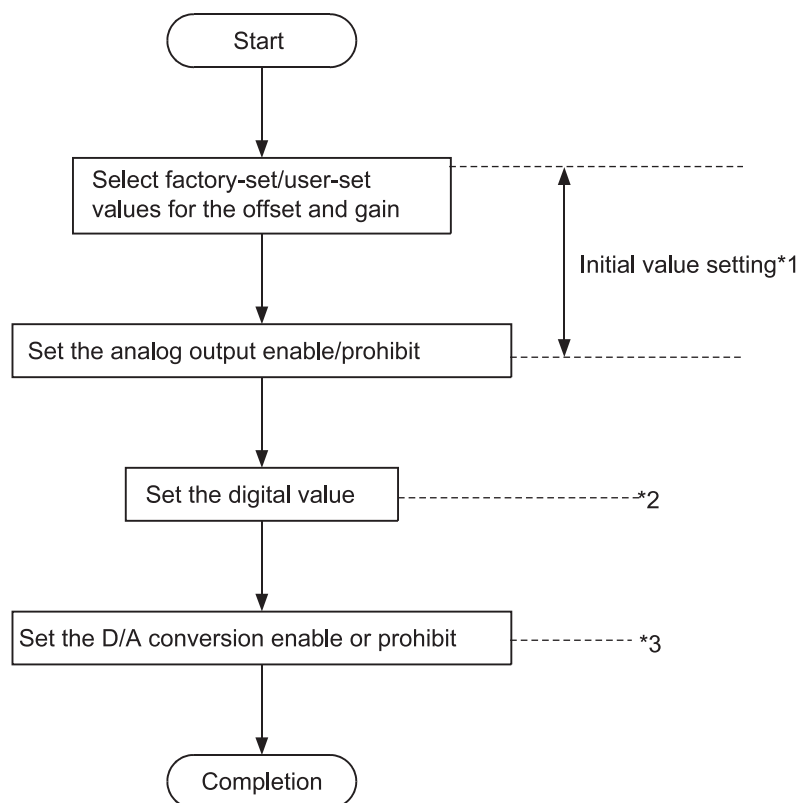

\*1 When using the QCPU (Q mode), you can use the remote device station initialization procedure registration function to make settings. When using the ACPU, QCPU (A mode) or QnACPU, use the sequence program to make settings.

\*2 The remote device station initialization procedure registration function cannot be used to make settings.  
Use the sequence program to make settings.

## 5.2 Conditions of Program Example

The program examples in this chapter are created under the following conditions.

(1) System configuration

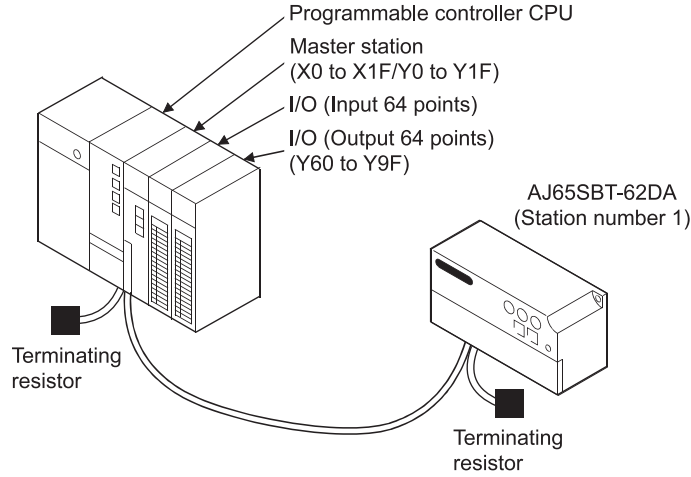

(2) Relationships between programmable controller CPU, master module and AJ65BT-64DAV

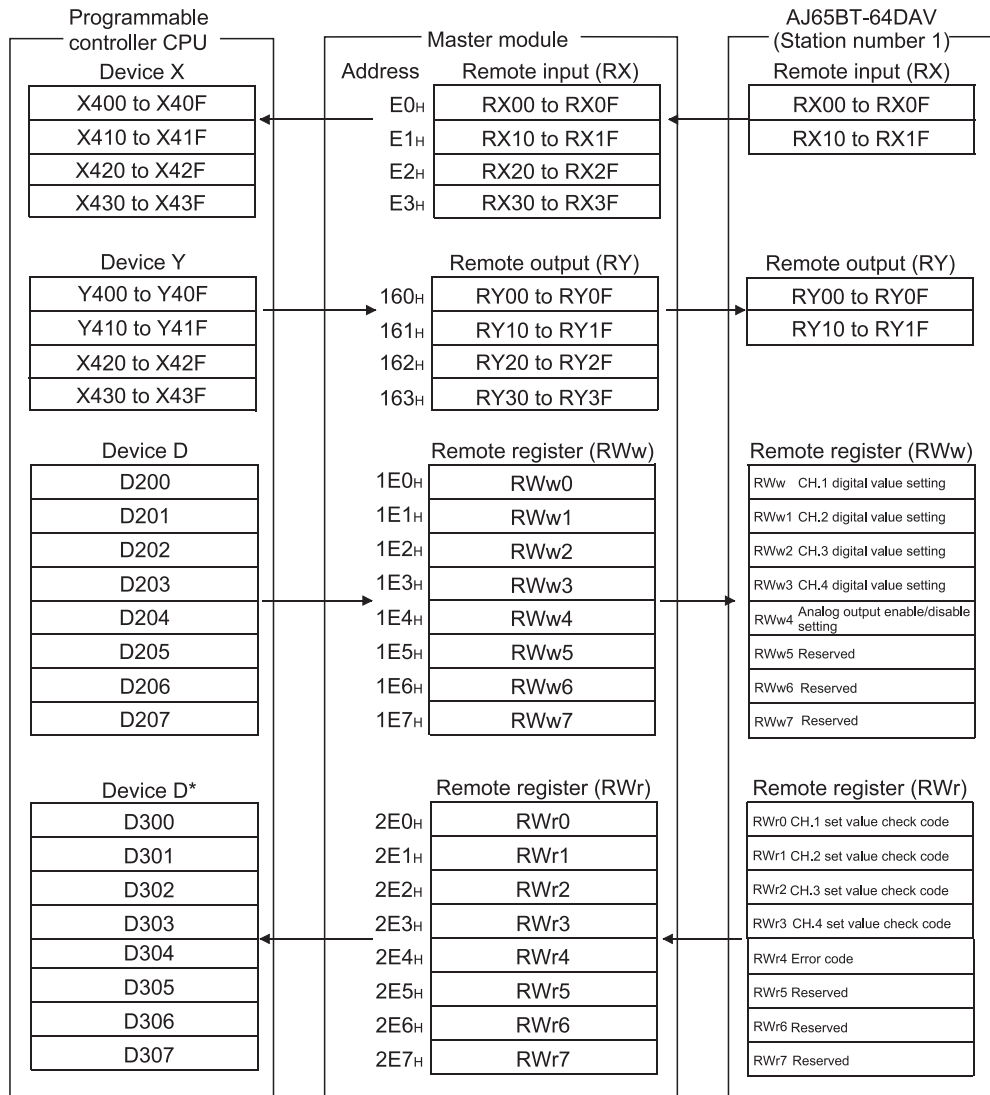

\* 1 In the program example (refer to Section 5.5) that uses the RRP A instruction (automatic refresh parameter setting) with the A CPU/Q CPU (A mode), RWr0 to RWr3 are assigned to D456 to D459.  
 \* 2 Although RX20 to RX3F and RY20 to RY3F are not used in the AJ65BT-64DAV, devices for them are reserved in a master module or CPU module.

POINT
<p>Some CPU modules may not accept the devices used in the program example in this chapter. For the setting ranges of the devices, refer to the user's manual of the CPU module used.</p> <p>For the A1SHCPU, for example, devices X100, Y100 and later are unusable. Use such devices as B and M.</p>

## (3) Initial settings

Setting Item	Settings
Offset/gain value selection	Factory setting
Analog output enable/disable setting (RWw4)	Channels 1, 2, 3, 4: enable

## (4) Other settings

Setting Item	Settings
CH.1 digital value setting (RWw0)	50
CH.2 digital value setting (RWw1)	100
CH.3 digital value setting (RWw2)	200
CH.4 digital value setting (RWw3)	3000
CH.1 analog output enable/disable flag (RY00)	Enable
CH.2 analog output enable/disable flag (RY01)	Enable
CH.3 analog output enable/disable flag (RY02)	Enable
CH.4 analog output enable/disable flag (RY03)	Enable



### 5.3 Program Example for Use of the QCPU (Q mode)

The program examples in this section are created under the following conditions.  
 GX Developer is used to set the network and automatic refresh parameters.  
 Using the remote device station initialization procedure registration function facilitates initial settings.

- (1) Parameter setting
  - (a) Network parameter setting

	1
Start I/O No	0000
Operational setting	Operational settings
Type	Master station
Master station data link type	PLC parameter auto start
Mode	Remote net(Ver.1 mode)
All connect count	1
Remote input(RX)	
Remote output(RY)	
Remote register(RW/r)	
Remote register(RW/w)	
Ver.2 Remote input(RX)	
Ver.2 Remote output(RY)	
Ver.2 Remote register(RW/r)	
Ver.2 Remote register(RW/w)	
Special relay(SB)	
Special register(SW)	
Retry count	3
Automatic reconnection station count	1
Stand by master station No.	
PLC down select	Stop
Scan mode setting	Asynchronous
Delay information setting	0
Station information setting	Station information
Remote device station initial setting	Initial settings
Interrupt setting	Interrupt settings

Station No	Station type	Expanded cyclic setting	Exclusive station count	Remote station points	Reserve/invalid station select	Intelligent buffer select(word)		
1/1	Remote device station	single	Exclusive station 2	64 points	No setting	Send	Receive	Automatic

- (b) Automatic refresh parameter setting

	1
Start I/O No	0000
Operational setting	Operational settings
Type	Master station
Master station data link type	PLC parameter auto start
Mode	Remote net(Ver.1 mode)
All connect count	1
Remote input(RX)	X400
Remote output(RY)	Y400
Remote register(RW/r)	D300
Remote register(RW/w)	D200
Ver.2 Remote input(RX)	
Ver.2 Remote output(RY)	
Ver.2 Remote register(RW/r)	
Ver.2 Remote register(RW/w)	
Special relay(SB)	SB0
Special register(SW)	SW0
Retry count	3
Automatic reconnection station count	1
Stand by master station No.	
PLC down select	Stop
Scan mode setting	Asynchronous
Delay information setting	0
Station information setting	Station information
Remote device station initial setting	Initial settings
Interrupt setting	Interrupt settings

- (2) Initial setting by remote device station initialization procedure registration
  - (a) Setting the target station number
    - Set the station number to which initial setting will be made.
    - Set the target station number to "1".

**Remote device station initial setting: Target station number setting: Module 1**

	Target station No.	No. of registered procedures		Target station No.	No. of registered procedures	
1	1	0	Regist procedure	9		Regist procedure
2			Regist procedure	10		Regist procedure

- (b) Setting the procedure registration
  - When the initial data processing request flag (RX18) turns on and the remote device station initialization procedure registration (SB0D) is set, the following data are registered to the AJ65BT-64DAV.

Procedure Execution Condition	Execution
Initial data processing request flag (RX18) turns on	Offset/gain value selection (RY04) is turned on (factory setting).
	Analog output enable/disable setting: channels 1, 2, 3, 4: enable (RWw4: 0000H)
	Initial data processing complete flag (RY18) is turned on.
	Initial data setting request flag (RY19) is turned on.
Initial data processing request flag (RX18) turns off	Initial data processing complete flag (RY18) is turned off.
Initial data setting complete flag (RX19) turns on	Initial data setting request flag (RY19) is turned off.

- (c) Setting results
  - The setting results are shown below.

**Remote device station initial setting: Procedure registration module 1: Target station 1**

Input format:

Execute Flag	Operational condition	Executorial condition			Details of execution		
		Condition Device	Device Number	Execute Condition	Write Device	Device Number	Write Data
Execute	Set new	RX	18	ON	RY	04	ON
Execute	Same as prev.set	RX	18	ON	RWw	04	0
Execute	Same as prev.set	RX	18	ON	RY	18	ON
Execute	Same as prev.set	RX	18	ON	RY	19	ON
Execute	Set new	RX	18	OFF	RY	18	OFF
Execute	Set new	RX	19	ON	RY	19	OFF

POINT
(1) If the remote device station initialization procedure registration directive (SB000D) is turned off after the initial processing, all RY signals that were turned on within the initial procedure registration turn off. Hence, turn on the "CH. <input type="checkbox"/> analog output enable/disable flag (RYn0, RYn1, RYn2, RYn3)" in the sequence program.
(2) When the initial setting (analog output enable/disable setting (RWwm+4)) has been changed, the remote device station initialization procedure registration function cannot be used. Change the initial setting in the sequence program.
(3) For the case where the remote device station initialization procedure registration function is not used but a sequence program is used to make setting, refer to the user's manual of the used master module.

(3) Program example

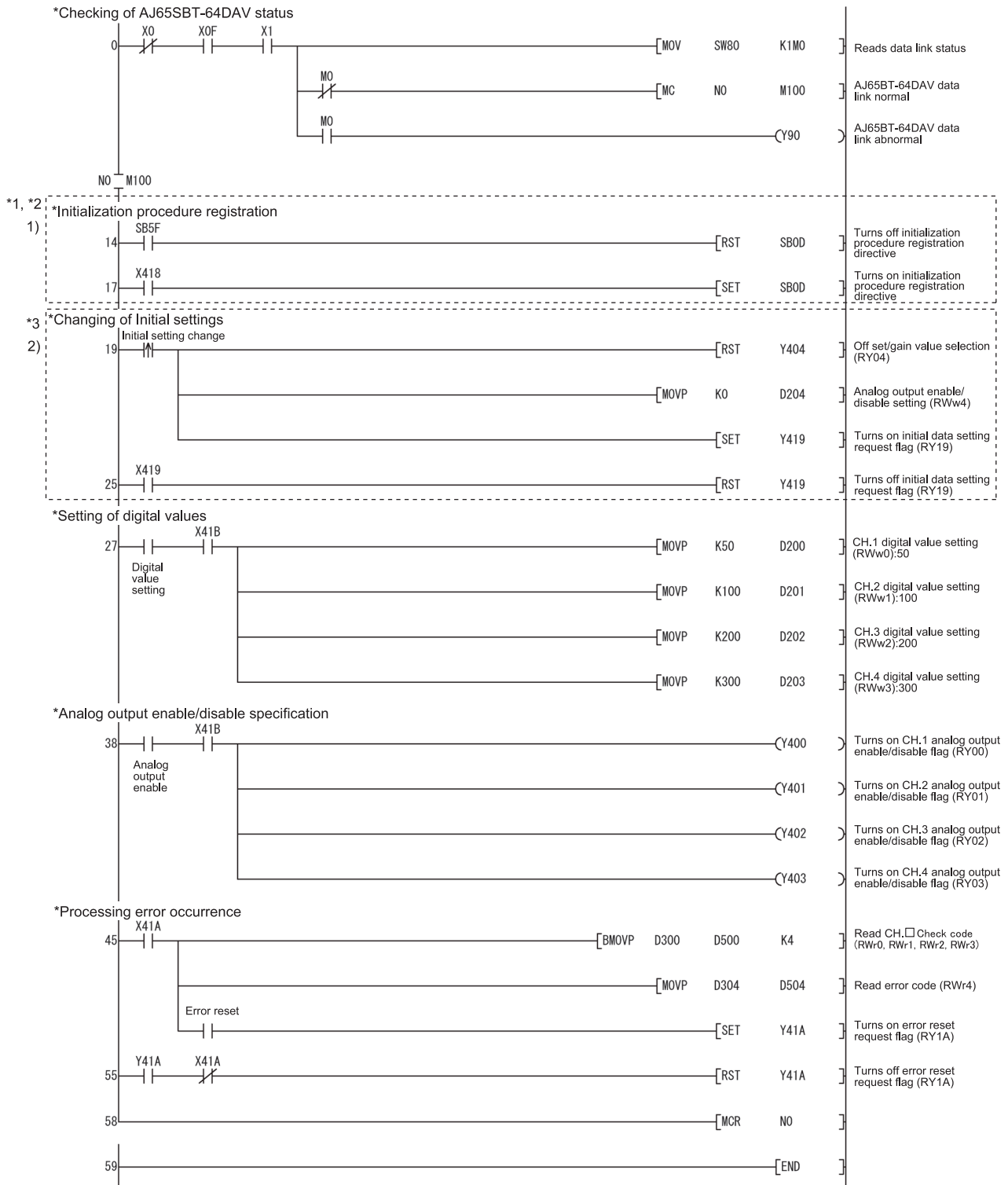

\*1: When making remote device station initialization procedure registration to multiple stations, correct the program within the dotted line 1) as shown below.

[System configuration]

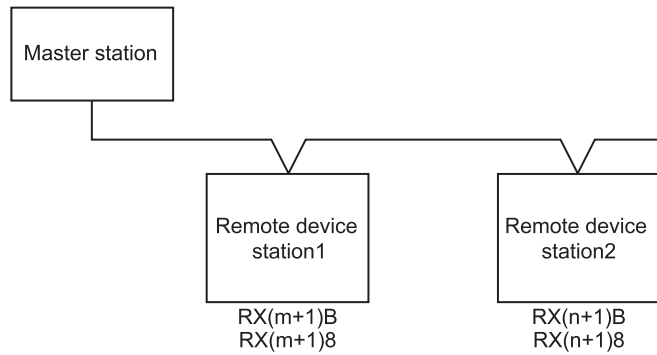

[Corrected program]

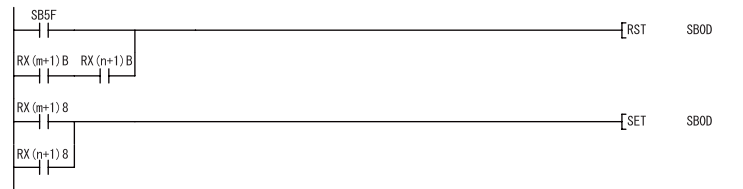

- RX(m+1)B and RX(n+1)B are remote READY.
- RX(m+1)8 and RX(n+1)8 are initial data processing request flags.

Insert the remote READY and initial data processing request flags for all the stations, to which the remote device station initialization procedure registration has been made, into the program.

[Usage in combination with other remote device stations]

- (1) Depending on the remote device stations to be used, the program enclosed by the dotted line 1) has two programming patterns as shown in the above and the below figures.  
(To check which pattern can be used, refer to the manual for the remote device to be used.)

[System configuration]

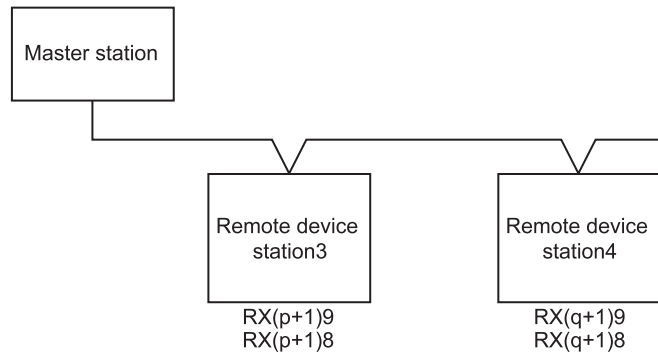

[Corrected program]

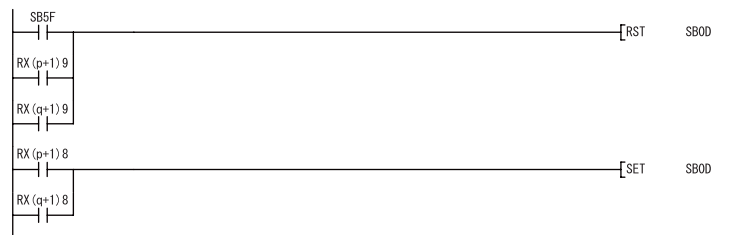

- RX(p+1)9 and RX(q+1)9 are initial data setting completion flags.
- RX(p+1)8 and RX(q+1)8 are initial data processing request flags.

- (2) When using the program enclosed by the dotted line 1) in combination with other remote device stations, correct the program as shown below.

[System configuration]

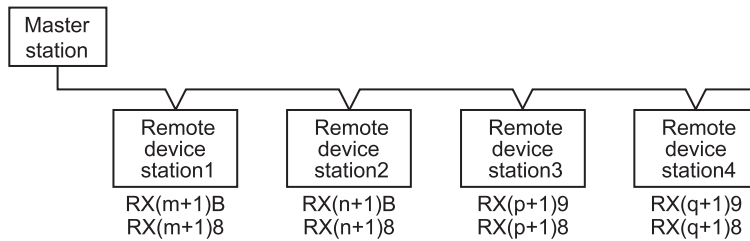

[Corrected program]

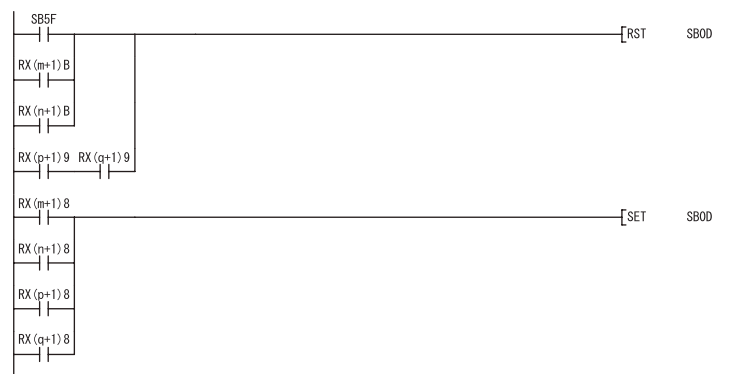

Note that the master module can register the initialization procedure of only the specified station out of the multiple remote device stations.

The master module supporting this function is the QJ61BT11N which serial No's first 5 digits is 08032 or later.

For details, refer to the CC-Link System Master/Local Module User's Manual, "CHAPTER 4 FUNCTIONS"

- \*2: Before the communication program is executed with remote device stations, the program enclosed by the dotted line 1) enables the initial setting by using the SB0D (remote device station initialization procedure registration instruction) and SB5F (completion status of remote device station initialization procedure). Initialization processing can't be made only by the parameter setting of GX Developer.
- \*3: The program enclosed by the dotted line 2) is necessary only when the initial settings are changed.

5.4 Program Example for Use of the QnACPU

GX Developer is used to set the network and automatic refresh parameters.

- (1) Parameter setting
  - (a) Network parameter setting

	1
Start I/O No.	0000
Type	Master station ▼
All connect count	1
Remote input(RX)	
Remote output(RY)	
Remote register(RW/r)	
Remote register(RW/w)	
Special relay(SB)	
Special register(SW)	
Retry count	3
Automatic reconnection station count	1
Wait master station No.	0
PLC down select	Stop ▼
Scan mode setting	Asynchronously ▼
Delay information setting	0
Station information setting	Station information

StationNo.	Station type	Exclusive station count	Reserve/invalid station select	Intelligent buffer select(word)		
				Send	Receive	Automatic
1 / 1	Remote device station ▼	Exclusive station 2 ▼	No setting ▼			

- (b) Automatic refresh parameter setting

	1
Start I/O No.	0000
Type	Master station ▼
All connect count	1
Remote input(RX)	X400
Remote output(RY)	Y400
Remote register(RW/r)	D300
Remote register(RW/w)	D200
Special relay(SB)	B0
Special register(SW)	W0
Retry count	3
Automatic reconnection station count	1
Wait master station No.	0
PLC down select	Stop ▼
Scan mode setting	Asynchronously ▼
Delay information setting	0
Station information setting	Station information

**POINT**

When the QnACPU is used, using "Y" as the remote output (RY) refresh device of the automatic refresh parameter may not hold the analog value even for the HOLD setting. For the HOLD setting, use "M" or "B" as the remote output (RY) refresh device.

(2) Program example

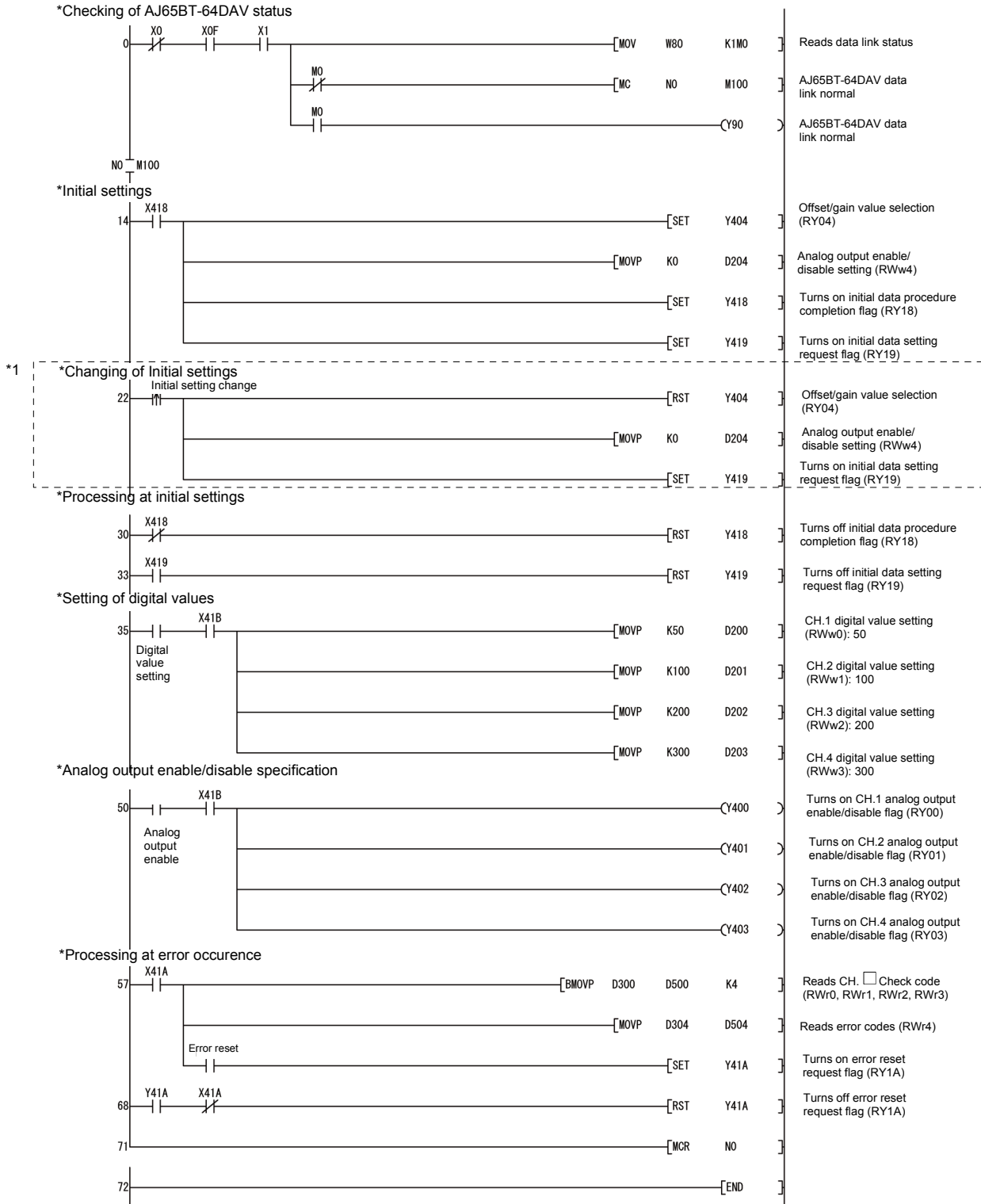

\*1: The program enclosed by the dotted line is necessary only when the initial settings are changed.



### 5.5 Program Example for Use of the ACPU/QCPU (A mode) (dedicated instructions)

A sequence program is used to set the network and automatic refresh parameters.

(1) Program example

\*Setting of network parameters using RLPA dedicated instruction

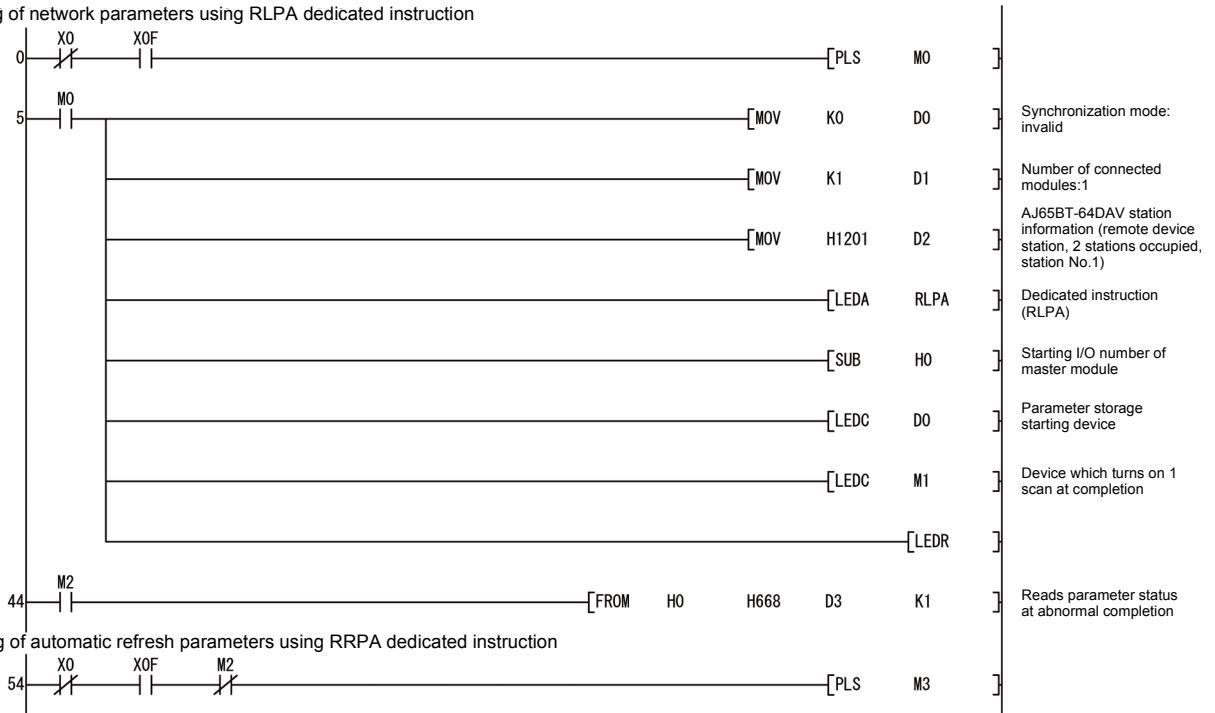

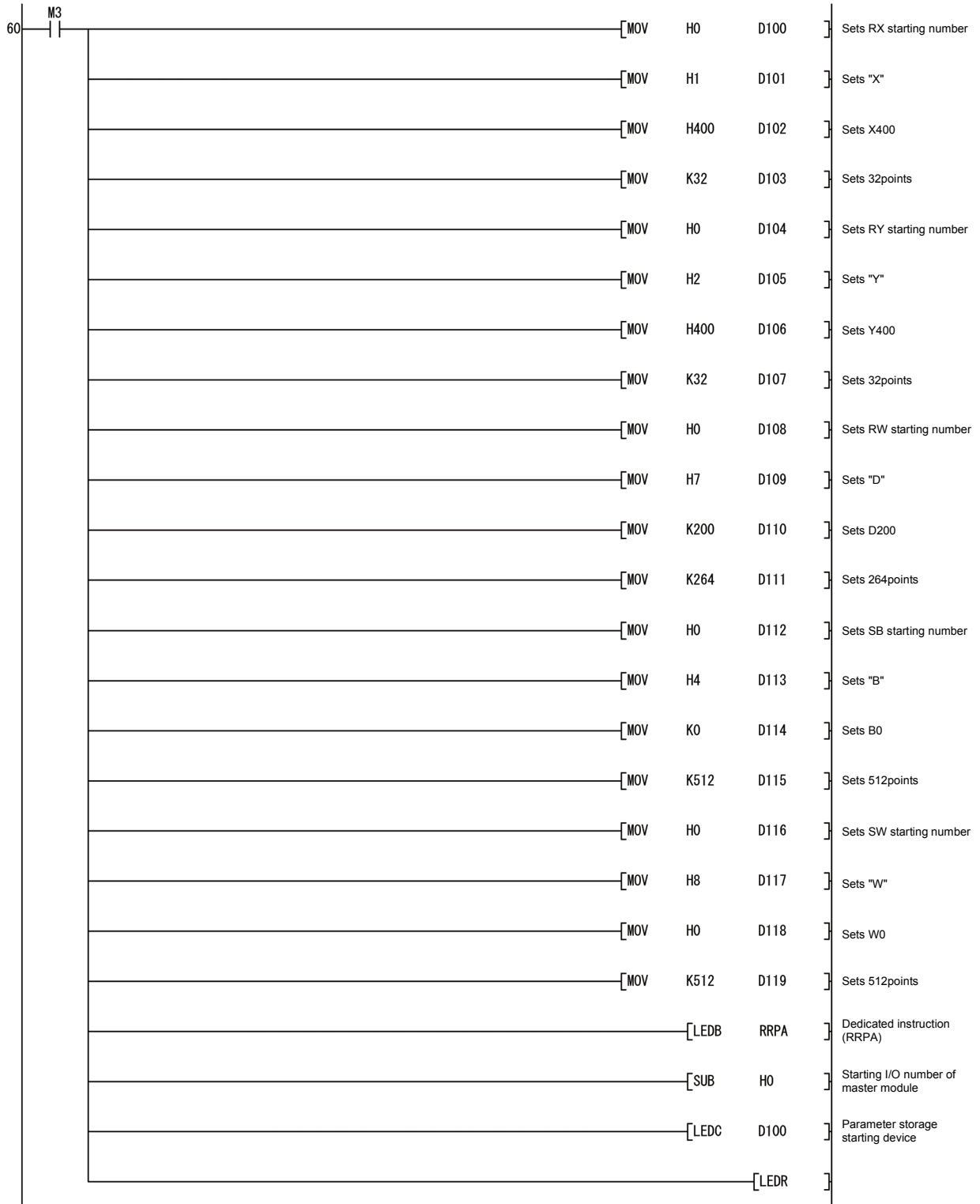

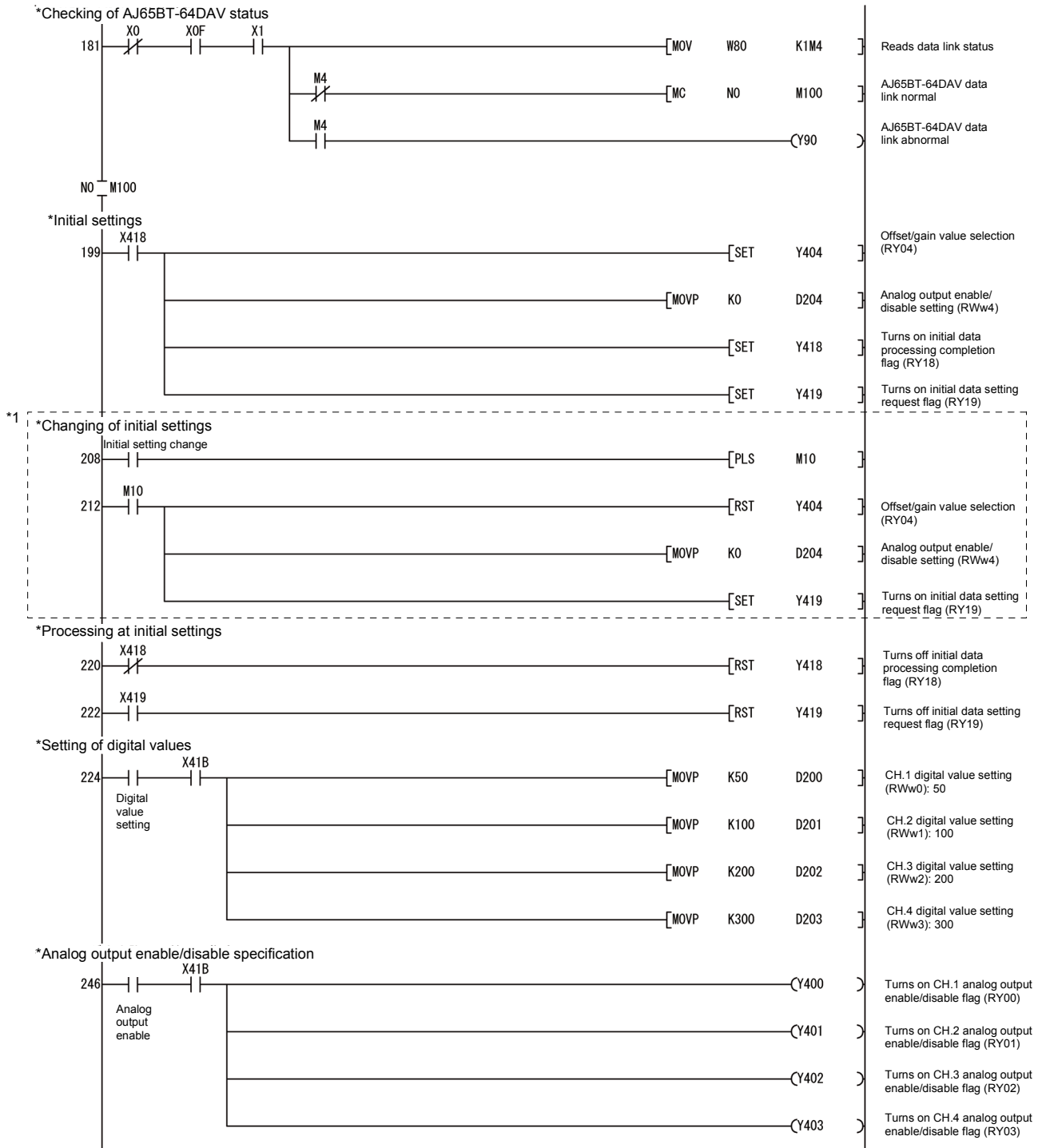

\*1: The program enclosed by the dotted line is necessary only when the initial settings are changed.

\*Processing at error occurrence

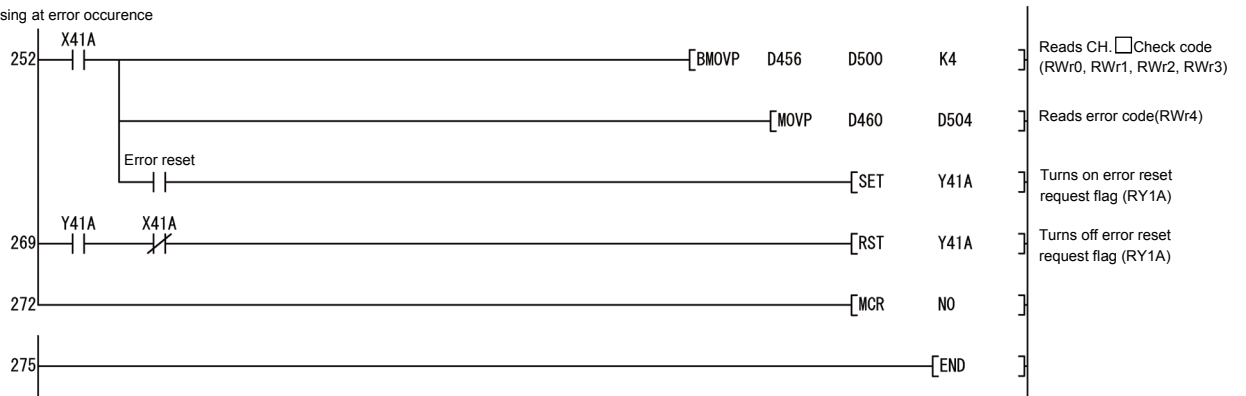

### 5.6 Program Example for Use of the ACPU/QCPU (A mode) (FROM/TO instructions)

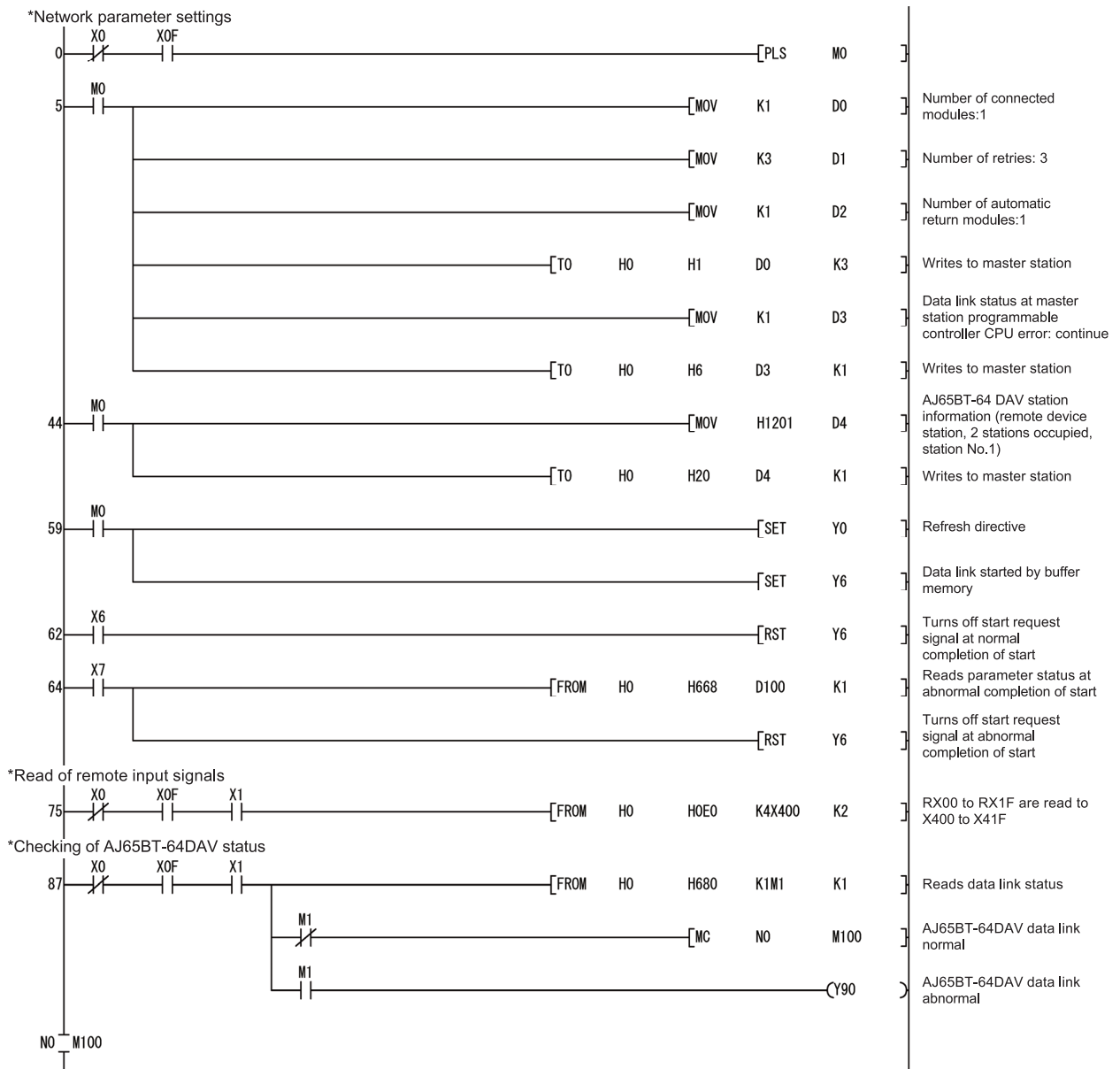

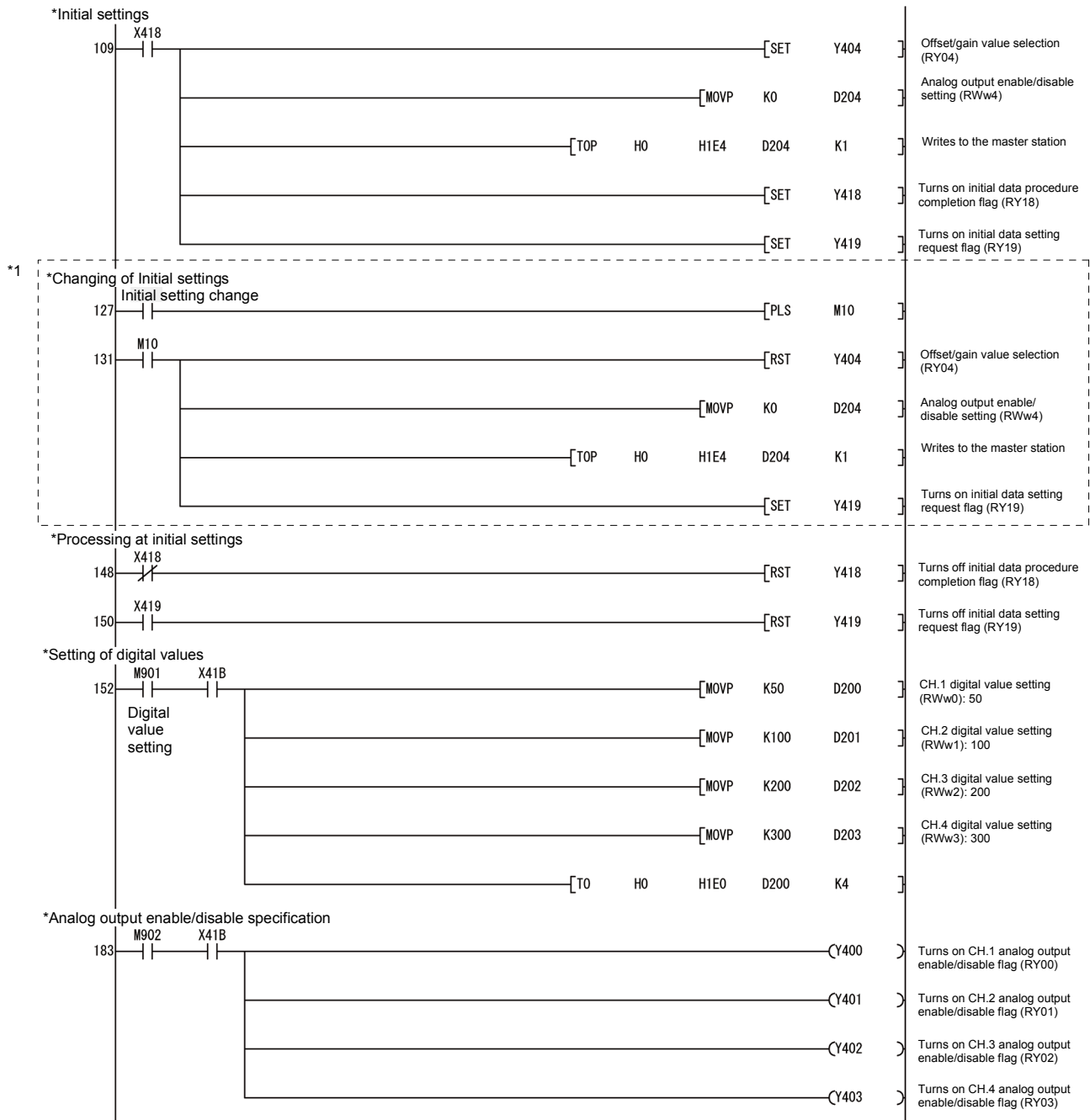

\*1: The program enclosed by the dotted line is necessary only when the initial settings are changed.

\*Processing at error occurrence

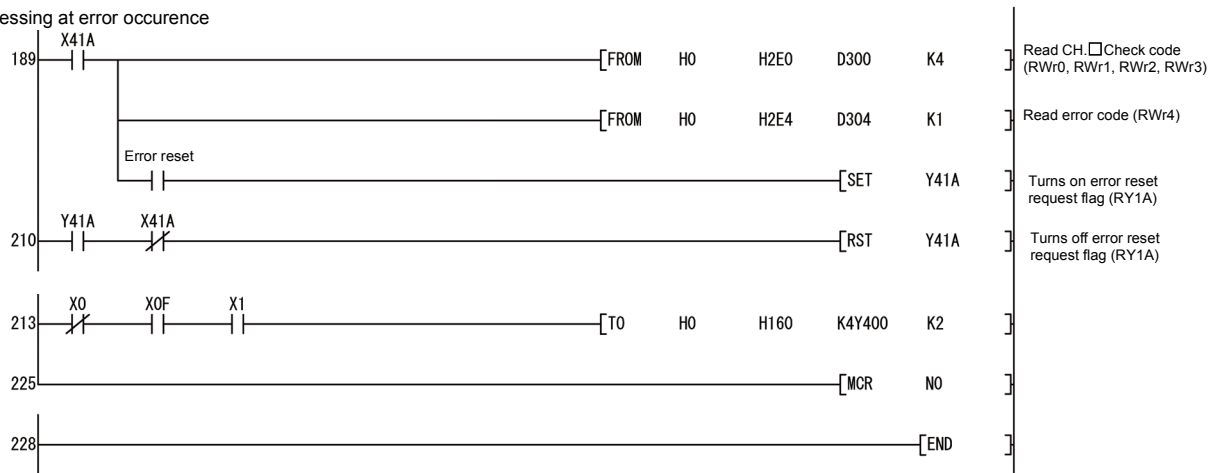

## 6. TROUBLESHOOTING

The details of the errors which may occur when using the AJ65BT-64DAV/DAI and troubleshooting are described.

### 6.1 Error Code List

When the data is written from the programmable controller CPU to the master module, and an error occurs (AJ65BT-64DAV/DAI RUN LED flashes), the error code is stored to the AJ65BT-64DAV/DAI remote register RW<sub>n</sub>+4.

Refer to Section 3.6.5 for the error code.

### 6.2 Troubleshooting

A simple troubleshooting method for using the AJ65BT-64DAV/DAI is described.

Refer to the programmable controller CPU and Master Module User's Manuals regarding problems related to the programmable controller CPU and master module.

(a) When the AJ65BT-64DAV/DAI RUN LED is flashing

Check item	Corrective action
There is an error in the write data.	Check the cause of the error using the error code, and correct the sequence program.
Is there a short between the TEST terminals (test mode)?	Release between the TEST terminals after adjusting the offset/gain.
Is it flashing in 0.1s intervals (fast-speed) in test mode?	Change the offset/gain adjustment to within the allowable range.

(b) When the AJ65BT-64DAV/DAI RUN LED is off

Check item	Corrective action
Is the 24VDC power on?	Check the power. (External power supply)
Is the 24VDC power voltage at the regulated value?	Set the voltage within the range 18 to 30V.
Is there a short between the TEST terminals(test mode)?	Release the TEST terminal after adjusting the offset/gain.

(c) When the AJ65BT-64DAV/DAI LINK RUN LED turns off

Refer to the master module troubleshooting section.

(d) When the AJ65BT-64DAV/DAI LINK ERR LED is flashing

Check item	Corrective action
<Flashing at regular intervals> Was the station number or baud rate switch setting changed during normal operation?	Return to the station number or baud rate used during normal operation.
<Flashing at irregular intervals> • You forgot fitting the termination resistors. • The module or CC-Link dedicated cable is affected by noise.	<ul style="list-style-type: none"> <li>• Check whether the termination resistors are fitted or not. If not, connect them and switch power on again.</li> <li>• Earth both ends of the shield wire of the CC-Link dedicated cable to the protective earth conductors via SLD and FG of the corresponding module.</li> <li>• Securely earth the FG terminal of the module to the protective earth conductor.</li> <li>• Securely earth the piping when running the wiring inside piping.</li> </ul>

(e) When the AJ65BT-64DAV/DAI LINK ERR LED is on

Check item	Corrective action
Is the station number or baud rate setting correct?	Set a correct station number or baud rate.



6.2.1 When a communication fault occurs between the master station and this module

If the station-number-overlapping bit is turned on in the link special register SW0098 to SW009B (station number overlapping status), check the AJ65BT-64DAV/DAI module of the corresponding station number by following the flow shown below:

Troubleshooting flow when the ERR LED on the master station is flashing

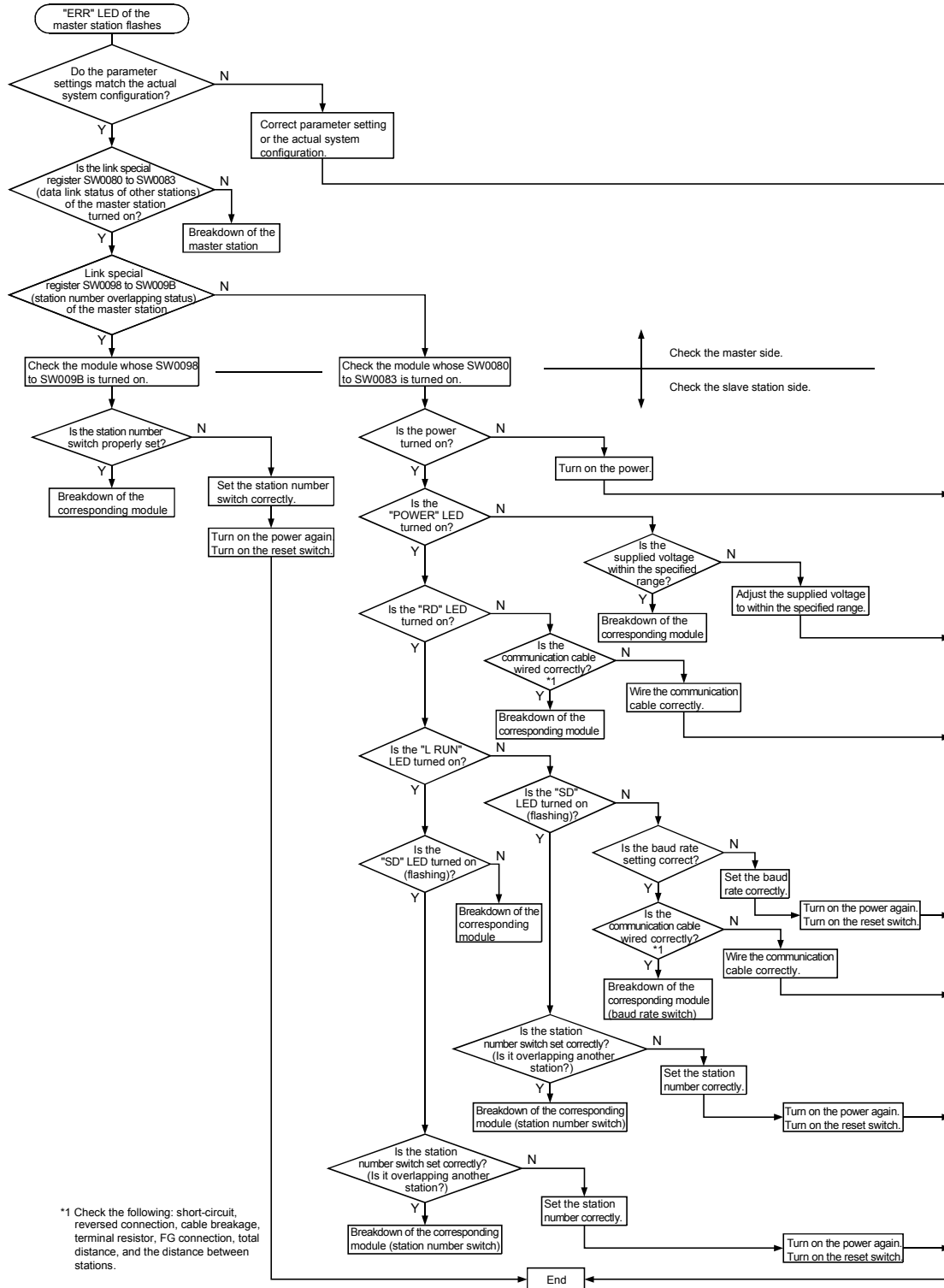

\*1 Check the following: short-circuit, reversed connection, cable breakage, terminal resistor, FG connection, total distance, and the distance between stations.

# APPENDIX

## Appendix 1 External Dimensions of the AJ65BT-64DAV

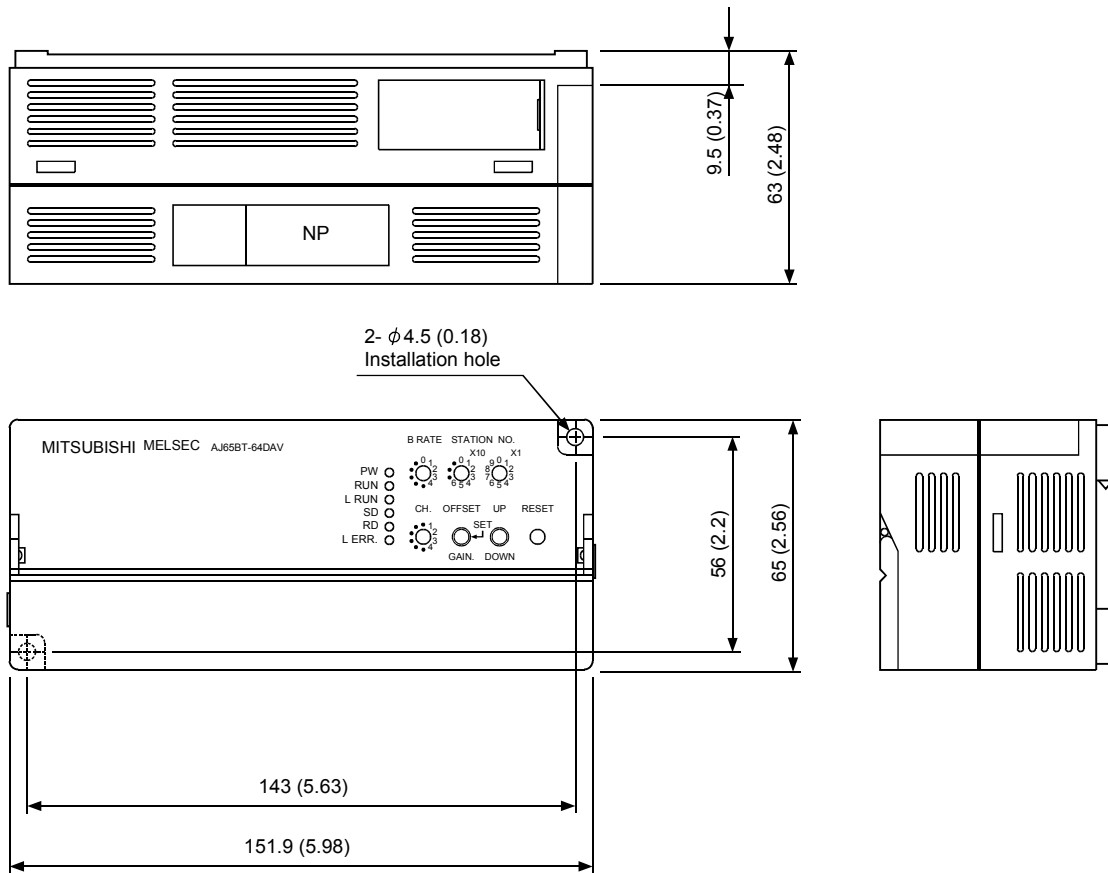

Unit: mm (inch)

Appendix 2 External Dimensions of the AJ65BT-64DAI

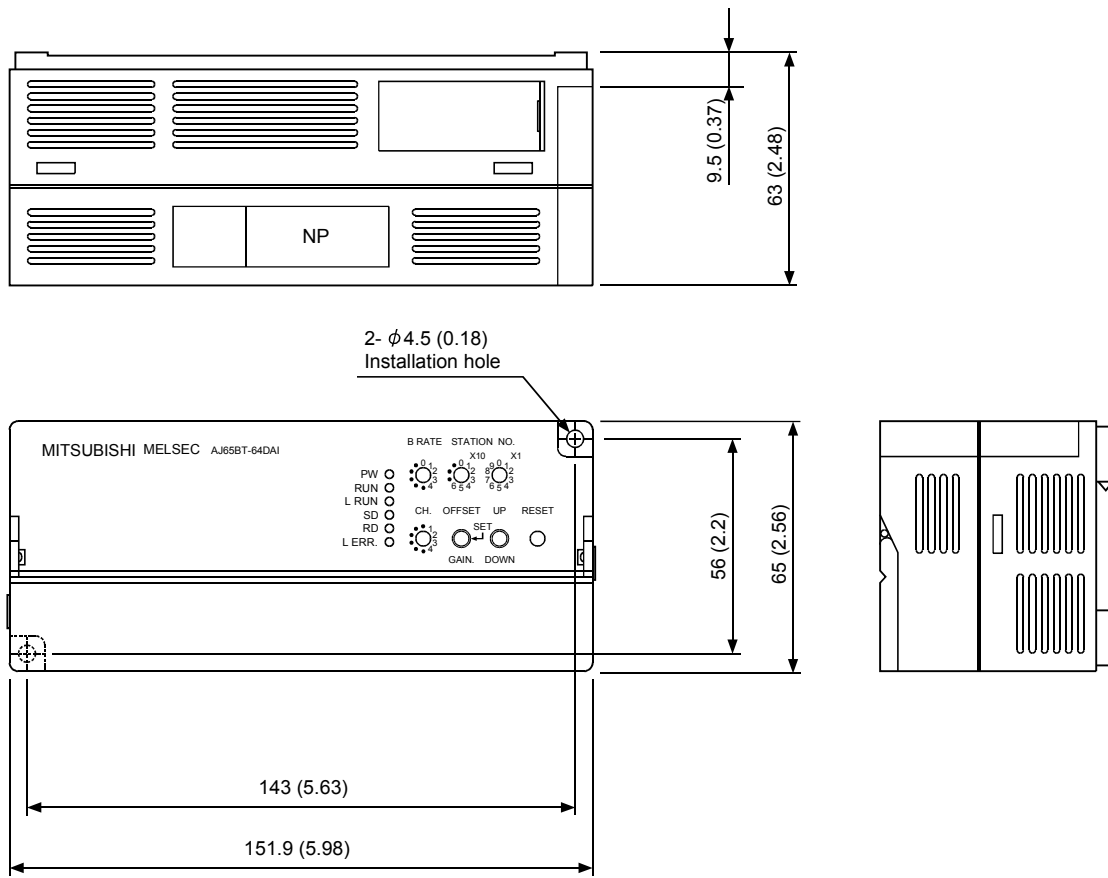

Unit: mm (inch)

# WARRANTY

Please confirm the following product warranty details before using this product.

## 1. Gratis Warranty Term and Gratis Warranty Range

If any faults or defects (hereinafter "Failure") found to be the responsibility of Mitsubishi occurs during use of the product within the gratis warranty term, the product shall be repaired at no cost via the sales representative or Mitsubishi Service Company.

However, if repairs are required onsite at domestic or overseas location, expenses to send an engineer will be solely at the customer's discretion. Mitsubishi shall not be held responsible for any re-commissioning, maintenance, or testing on-site that involves replacement of the failed module.

### [Gratis Warranty Term]

The gratis warranty term of the product shall be for one year after the date of purchase or delivery to a designated place.

Note that after manufacture and shipment from Mitsubishi, the maximum distribution period shall be six (6) months, and the longest gratis warranty term after manufacturing shall be eighteen (18) months. The gratis warranty term of repair parts shall not exceed the gratis warranty term before repairs.

### [Gratis Warranty Range]

- (1) The range shall be limited to normal use within the usage state, usage methods and usage environment, etc., which follow the conditions and precautions, etc., given in the instruction manual, user's manual and caution labels on the product.
- (2) Even within the gratis warranty term, repairs shall be charged for in the following cases.
  1. Failure occurring from inappropriate storage or handling, carelessness or negligence by the user. Failure caused by the user's hardware or software design.
  2. Failure caused by unapproved modifications, etc., to the product by the user.
  3. When the Mitsubishi product is assembled into a user's device, Failure that could have been avoided if functions or structures, judged as necessary in the legal safety measures the user's device is subject to or as necessary by industry standards, had been provided.
  4. Failure that could have been avoided if consumable parts (battery, backlight, fuse, etc.) designated in the instruction manual had been correctly serviced or replaced.
  5. Failure caused by external irresistible forces such as fires or abnormal voltages, and Failure caused by force majeure such as earthquakes, lightning, wind and water damage.
  6. Failure caused by reasons unpredictable by scientific technology standards at time of shipment from Mitsubishi.
  7. Any other failure found not to be the responsibility of Mitsubishi or that admitted not to be so by the user.

## 2. Onerous repair term after discontinuation of production

- (1) Mitsubishi shall accept onerous product repairs for seven (7) years after production of the product is discontinued. Discontinuation of production shall be notified with Mitsubishi Technical Bulletins, etc.
- (2) Product supply (including repair parts) is not available after production is discontinued.

## 3. Overseas service

Overseas, repairs shall be accepted by Mitsubishi's local overseas FA Center. Note that the repair conditions at each FA Center may differ.

## 4. Exclusion of loss in opportunity and secondary loss from warranty liability

Regardless of the gratis warranty term, Mitsubishi shall not be liable for compensation of damages caused by any cause found not to be the responsibility of Mitsubishi, loss in opportunity, lost profits incurred to the user by Failures of Mitsubishi products, special damages and secondary damages whether foreseeable or not, compensation for accidents, and compensation for damages to products other than Mitsubishi products, replacement by the user, maintenance of on-site equipment, start-up test run and other tasks.

## 5. Changes in product specifications

The specifications given in the catalogs, manuals or technical documents are subject to change without prior notice.



SH(NA)-3615-G(1012)MEE

MODEL: AJ65BT-64DA-U-S-E

MODEL CODE: 13J895

## **MITSUBISHI ELECTRIC CORPORATION**

HEAD OFFICE : TOKYO BUILDING, 2-7-3 MARUNOUCHI, CHIYODA-KU, TOKYO 100-8310, JAPAN  
NAGOYA WORKS : 1-14, YADA-MINAMI 5-CHOME, HIGASHI-KU, NAGOYA, JAPAN

When exported from Japan, this manual does not require application to the  
Ministry of Economy, Trade and Industry for service transaction permission.

Specifications subject to change without notice.