

# MITSUBISHI

## Insulation Displacement Connector for MELSEC-Q Series 32-Point I/O Module

MITSUBISHI  
PROGRAMMABLE LOGIC CONTROLLER

### User's Manual

## Q6TA32

Thank you for purchasing the Mitsubishi programmable logic controller MELSEC-Q series.

Prior to use, please read this manual thoroughly and familiarize yourself with the product

### MELSEC-Q

Mitsubishi Programmable  
Logic Controller

MODEL	Q6TA32-U-JE
MODEL CODE	13JT92
IB(NA)-0800228-B(0301)MEE	

# ● SAFETY PRECAUTIONS ●

(Read these precautions before using.)

When using Mitsubishi equipment, thoroughly read this manual and the related manuals introduced in this manual. Also pay careful attention to safety and handle the module correctly.

These ● SAFETY PRECAUTIONS ● classify the safety precautions into two categories: “DANGER” and “CAUTION”.



Procedures which may lead to a dangerous condition and cause death or serious injury, if not carried out correctly.



Procedures which may lead to a dangerous condition and cause superficial to medium injury, or physical damage only, if not carried out correctly.

Depending on circumstances, procedures indicated by  CAUTION may also cause serious accidents.

In any case, it is important to follow the directions for usage.

Store this manual in a safe place so that you can take it out and read it whenever necessary. Always forward it to the end user.

## [DESIGN PRECAUTIONS]

### CAUTION

- Do not bunch the control wires or communication cables with the main circuit or power line, or install them close to each other. They should be installed 100 mm (3.94 inch) or more from each other. Otherwise, noise may occur and result in malfunction.

## [INSTALLATION PRECAUTIONS]

### CAUTION

- Use the PLC in an environment that meets the general specifications given in the CPU user's manual. Using this PLC in an environment outside the range of the general specifications may cause electric shock, fire, malfunction, and damage to or deterioration of the product.
- When installing this product on an I/O module, securely install it using 2 fixing screws (M2.6). Incorrect installation may cause this product to fall out, the I/O module to malfunction or similar problems to occur.

## [INSTALLATION PRECAUTIONS]

### CAUTION

- Always install or remove this product after switching power off externally in all phases.  
Otherwise, the I/O module may go down or malfunction.

## [WIRING PRECAUTIONS]

### DANGER

- Always start wiring after switching power off externally in all phases.  
Otherwise, an electric shock may occur or this product may be damaged.

### CAUTION

- When wiring this product, be sure that the terminal layout is correct and the I/O module's rated voltage is used. Connecting a power supply out of the rating or miswiring could result in fire or damage.
- Make sure that the applicable wires are crimped onto the terminal conductors before using this product.
- Be careful not to let foreign matters such as sawdust or wire chips get inside this product or the I/O module. These may cause fire, damage, or malfunction.

## [STARTING AND MAINTENANCE PRECAUTIONS]

### DANGER

- Do not insert or pull out the wires when power is on.  
It may cause a malfunction or electric shock.
- Always clean or retighten fixing screws after switching power off externally in all phases.  
Otherwise, the I/O module may malfunction.

### CAUTION

- Do not disassemble or rebuild this product.  
It may cause accidents, malfunction, injury, or fire.
- Always install or remove this product after switching power off externally in all phases.  
Otherwise, the I/O module may go down or malfunction.

## [DISPOSAL PRECAUTIONS]

### CAUTION

- When disposing this product, handle it as industrial waste.

## REVISIONS

\* The manual number is given on the bottom right of the top cover.

Print Date	*Manual Number	Revision
Feb., 2002	IB(NA)-0800228-A	First edition
Jan., 2003	IB(NA)-0800228-B	Manual title change Pressure-Displacement Terminal Block Adaptor for MELSEC-Q Series 32-Point I/O Module

This manual confers no industrial property rights or any rights of any other kind, nor does it confer any patent licenses. Mitsubishi electric Corporation cannot be held responsible for any problems involving industrial property rights which may occur as a result of using the contents noted in this manual.

© 2002 MITSUBISHI ELECTRIC CORPORATION

## CONTENTS

SAFETY PRECAUTIONS.....	A-1
REVISIONS.....	A-3
Manuals.....	A-3
1. OVERVIEW .....	1
2. PERFORMANCE SPECIFICATIONS .....	2
3. NAMES OF PARTS .....	3
4. HANDLING INSTRUCTIONS .....	3
5. WIRING .....	4
5.1 Wiring Instructions .....	4
5.2 External Wiring.....	4
5.3 Wiring Procedure .....	5
6. EXTERNAL DIMENSIONS .....	7

### Manuals

The following manual is related to this product.  
Please order it if necessary.

#### Related manual

Manual Name	Manual Number (Model Code)
I/O Module Type Building Block User's Manual	SH-080042 (13JL99)

# 1. OVERVIEW

This manual describes the specifications, handling, part names and others of the Q6TA32 insulation displacement connector for MELSEC-Q series 32-point I/O module (hereinafter referred to as the Q6TA32).

The Q6TA32 is to be connected to the connector of the Q Series 40-pin connector type 32-point I/O module in order to convert the module connector into an insulation displacement connector.

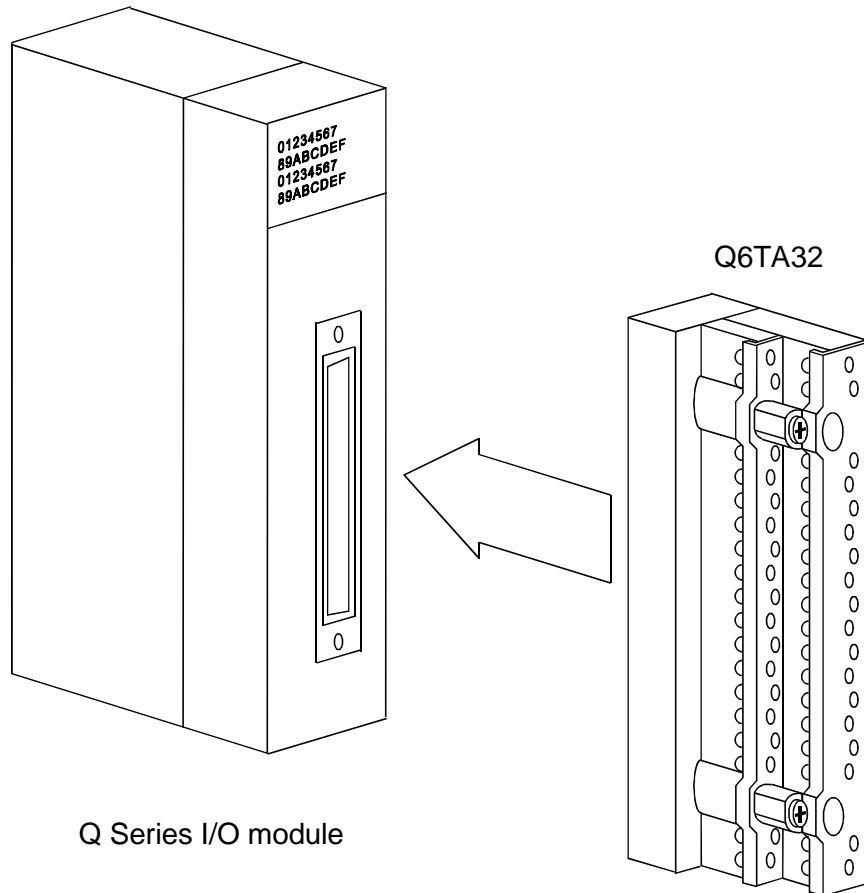

## Packing list

Type	Product
Q6TA32	32-point insulation displacement connector
Q6TA32-TOL	Wiring tool (sold separately)

## 2. PERFORMANCE SPECIFICATIONS

The following table lists the performance specifications of the Q6TA32.

Item	Specifications	
Applicable model	QX41, QX71, QY41P, QY71	
Applicable wire *2	Polyvinyl chloride wire (twisted wire) Nominal 0.5 mm <sup>2</sup> (AWG20) max. insulation diameter: φ1.9 mm (0.07 inch)	
Number of connectable wire	1	
Tensile strength *1 of wire	To the left	35N
	Forward	22N
	Upward or downward	60N
Number of wire insertion/ disconnection times	30	
Max. allowable voltage	250VAC	
Max. allowable current	3ADC	
Contact resistance	100m (327.8 feet) Ω or less	
Weight	0.08 kg (0.18 lb.)	

\*1: Direction of tensile strength of wire

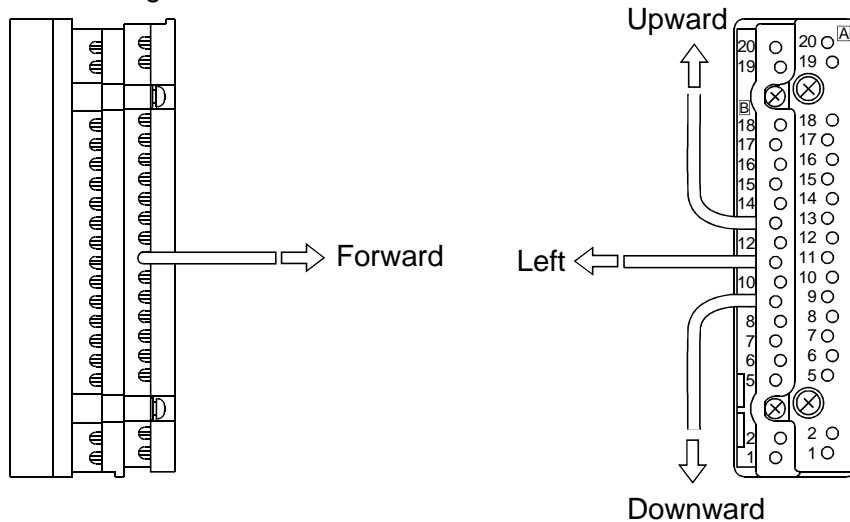

\*2: Use the "UL STYLE 1007" or "CSA TYPE TR-64" type cable.

### 3. NAMES OF PARTS

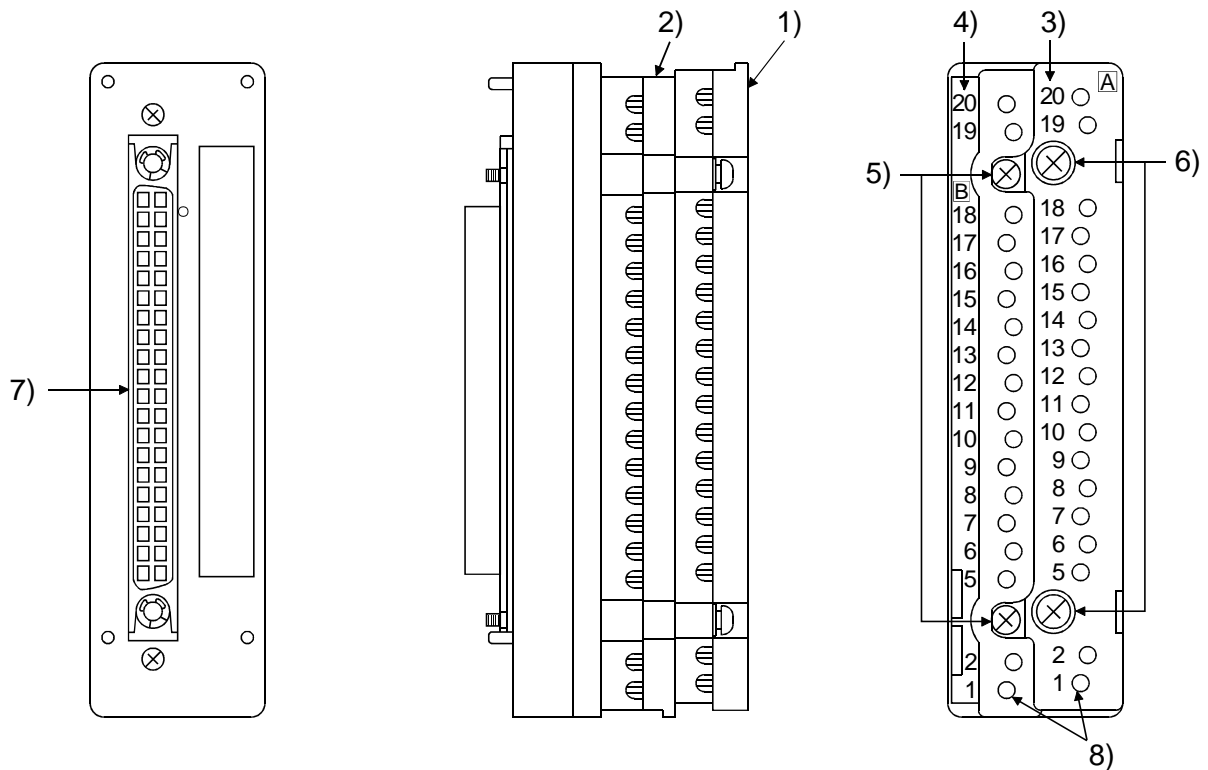

No.	Name	Description
1)	Line A cover	Cover for the insulation displacement connector line A
2)	Line B cover	Cover for the insulation displacement connector line B
3)	Terminal number (Line A)	Indicate the I/O module pin number A1 to A20 corresponding to the insulation displacement terminals.
4)	Terminal number (Line B)	Indicate the I/O module pin number B1 to B20 corresponding to the insulation displacement terminals.
5)	Cover fixing screw	Screw for fixing the cover (M2.6 screw)
6)	Insulation displacement connector fixing screw	Screw for fixing the Q6TA32 to the I/O module connector (M2.6 screw)
7)	Connector	Connector for connection to the I/O module.
8)	Tester lead-in port	Hole through which a tester lead is drawn for continuity check.

### 4. HANDLING INSTRUCTIONS

- (1) Do not use solid wires with this connector.
- (2) Do not drop the connector case and wiring tool or give them high impact since they are made of resin.
- (3) Do not disassemble the connector case.  
It may cause a failure.
- (4) Tighten the fixing screws and cover fixing screws within the following ranges.

Screw	Tightening Torque Range
Insulation displacement connector fixing screw (M2.6 screw)	21 to 28 N • cm
Cover fixing screw (M2.6 screw)	21 to 28 N • cm

- (5) When the Q6TA32 is installed to the I/O module, it is 9 mm (0.35 inch) out of the I/O module bottom. (Refer to "6. OUTLINE DRAWING".)  
Pay attention to the installation position.
- (6) The Q6TA32 cannot be used with any model that is not mentioned as the applicable model in the performance specifications.

## 5. WIRING

### 5.1 Wiring Instructions

- (1) Do not strip the insulation of the connectable wire before wiring.
- (2) The number of connectable wire per terminal is 1.
- (3) Wire the far side line B terminals first.
- (4) To prevent the wires from pushing the adjacent modules, connect them after pulling them toward you within the wire's tensile strength range given in the performance specifications.

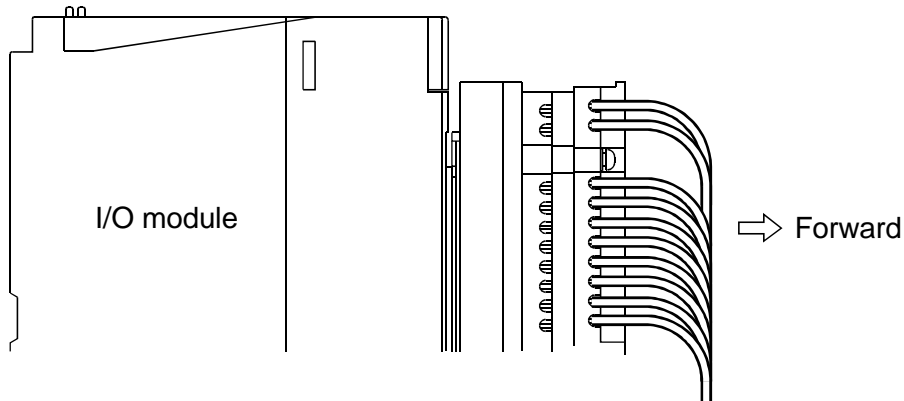

- (5) During and after wiring, do not apply loads larger than the wire's tensile strength given in the performance specifications to the wires.
- (6) When reusing the wire that has been connected to this connector once, cut off its insulation displacement end face in advance.

### 5.2 External Wiring

The following table indicates the terminal number and the corresponding signal name.

(When the head I/O number of the I/O module is set to 0)

Input Module (QX41, QX71)				Output Module (QY41P, QY71 *)			
Terminal number	Signal name	Terminal number	Signal name	Terminal number	Signal name	Terminal number	Signal name
B20	X00	A20	X10	B20	Y00	A20	Y10
B19	X01	A19	X11	B19	Y01	A19	Y11
B18	X02	A18	X12	B18	Y02	A18	Y12
B17	X03	A17	X13	B17	Y03	A17	Y13
B16	X04	A16	X14	B16	Y04	A16	Y14
B15	X05	A15	X15	B15	Y05	A15	Y15
B14	X06	A14	X16	B14	Y06	A14	Y16
B13	X07	A13	X17	B13	Y07	A13	Y17
B12	X08	A12	X18	B12	Y08	A12	Y18
B11	X09	A11	X19	B11	Y09	A11	Y19
B10	X0A	A10	X1A	B10	Y0A	A10	Y1A
B9	X0B	A9	X1B	B9	Y0B	A9	Y1B
B8	X0C	A8	X1C	B8	Y0C	A8	Y1C
B7	X0D	A7	X1D	B7	Y0D	A7	Y1D
B6	X0E	A6	X1E	B6	Y0E	A6	Y1E
B5	X0F	A5	X1F	B5	Y0F	A5	Y1F
B4 *2		A4 *2		B4 *2		A4 *2	
B3 *2		A3 *2		B3 *2		A3 *2	
B2	COM	A2	Empty	B2	12/24VDC *1	A2	COM
B1	COM	A1	Empty	B1	12/24VDC *1	A1	COM

\*1: B1 and B2 of the QY71 are used at 5/12VDC.

\*2: The Q6TA32 does not have the terminal number A3, A4, B3 and B4.



## 5.3 Wiring Procedure

### (1) Wire connection

- 1) Install the Q6TA32 to the I/O module with the insulation displacement connector fixing screws, loosen the cover fixing screws, and remove the covers.

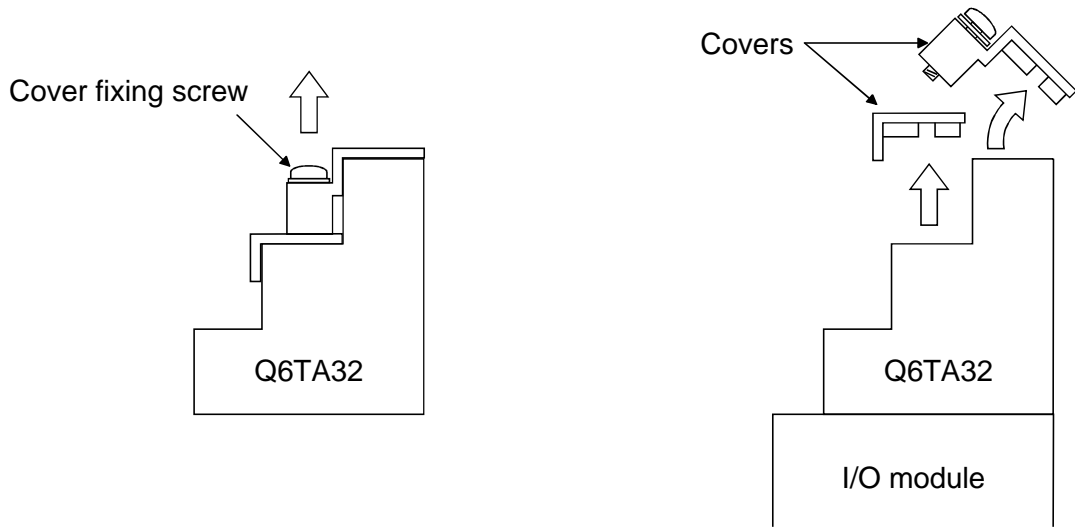

- 2) Insert the wire along the guide inside the Q6TA32 without a gap, push it in gently with your finger to temporarily hold it, and push it far enough with the wiring tool.

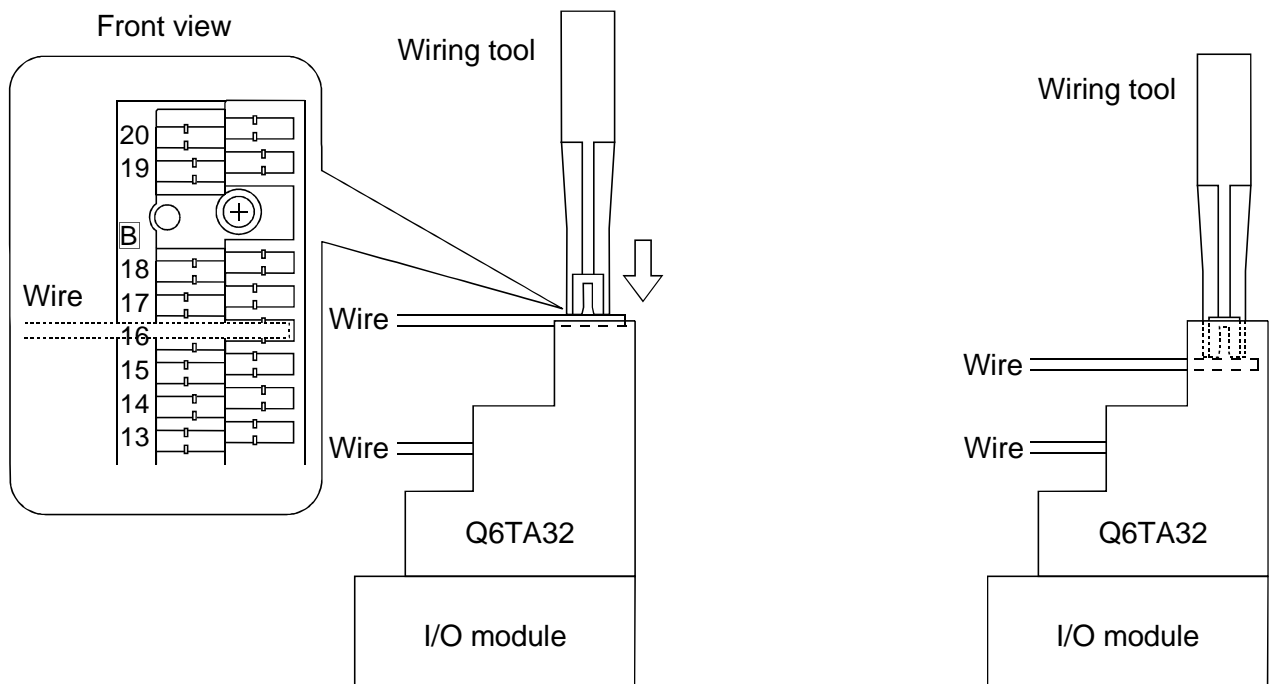

When wiring Line A (right side), check the numeral of Line B (left side) to confirm the terminal number to be wired.

3) Install the covers to the Q6TA32 and tighten the cover fixing screws.

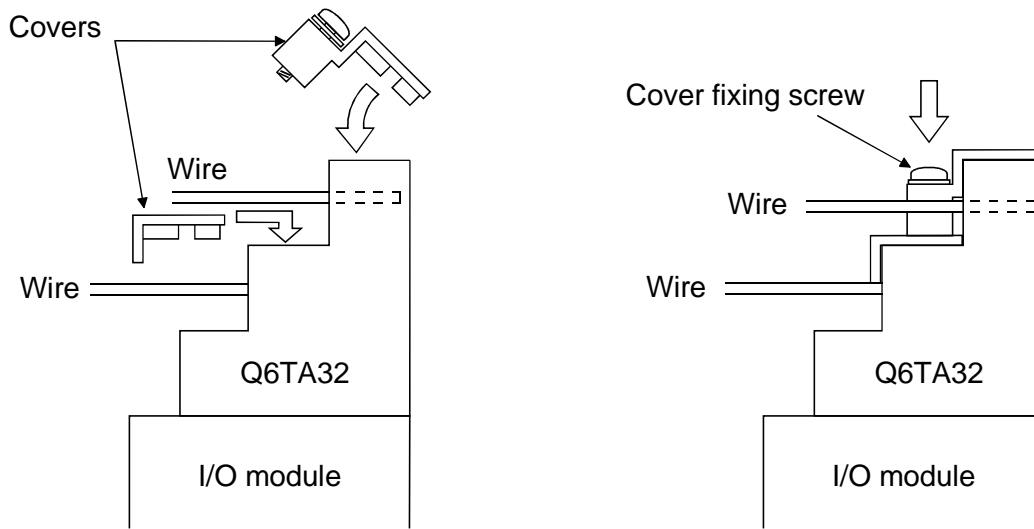

4) Using a tester, make a continuity check.

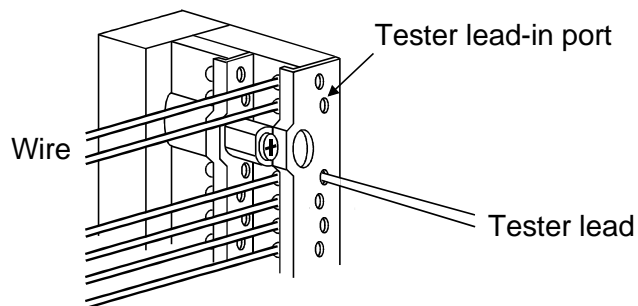

(2) Disconnecting the wire

Loosen the cover fixing screws, remove the covers, and pull the wire toward you.

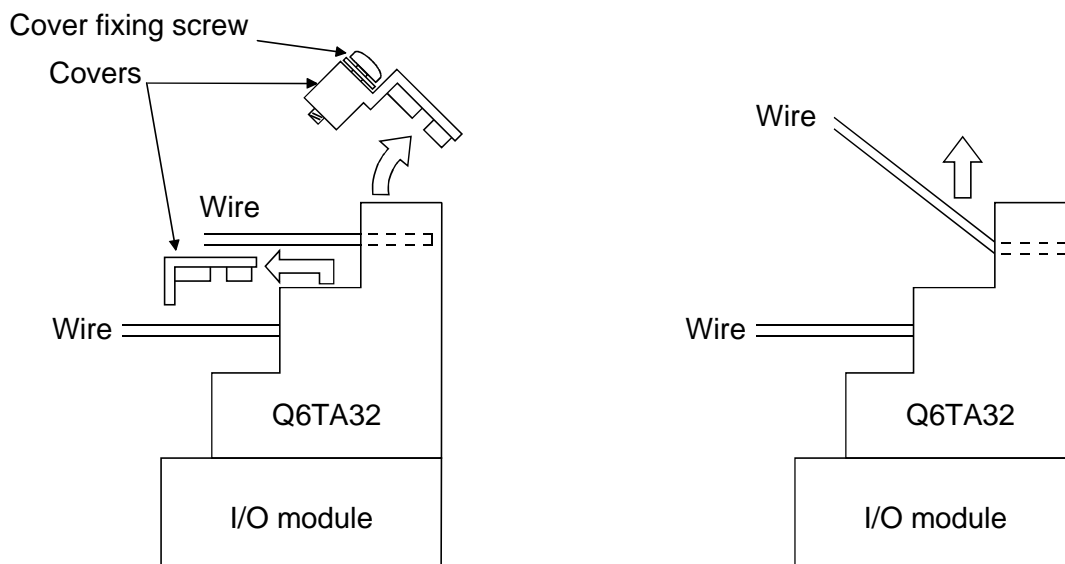

## 6. EXTERNAL DIMENSIONS

(1) Q6TA32 (When mounted on an I/O module)

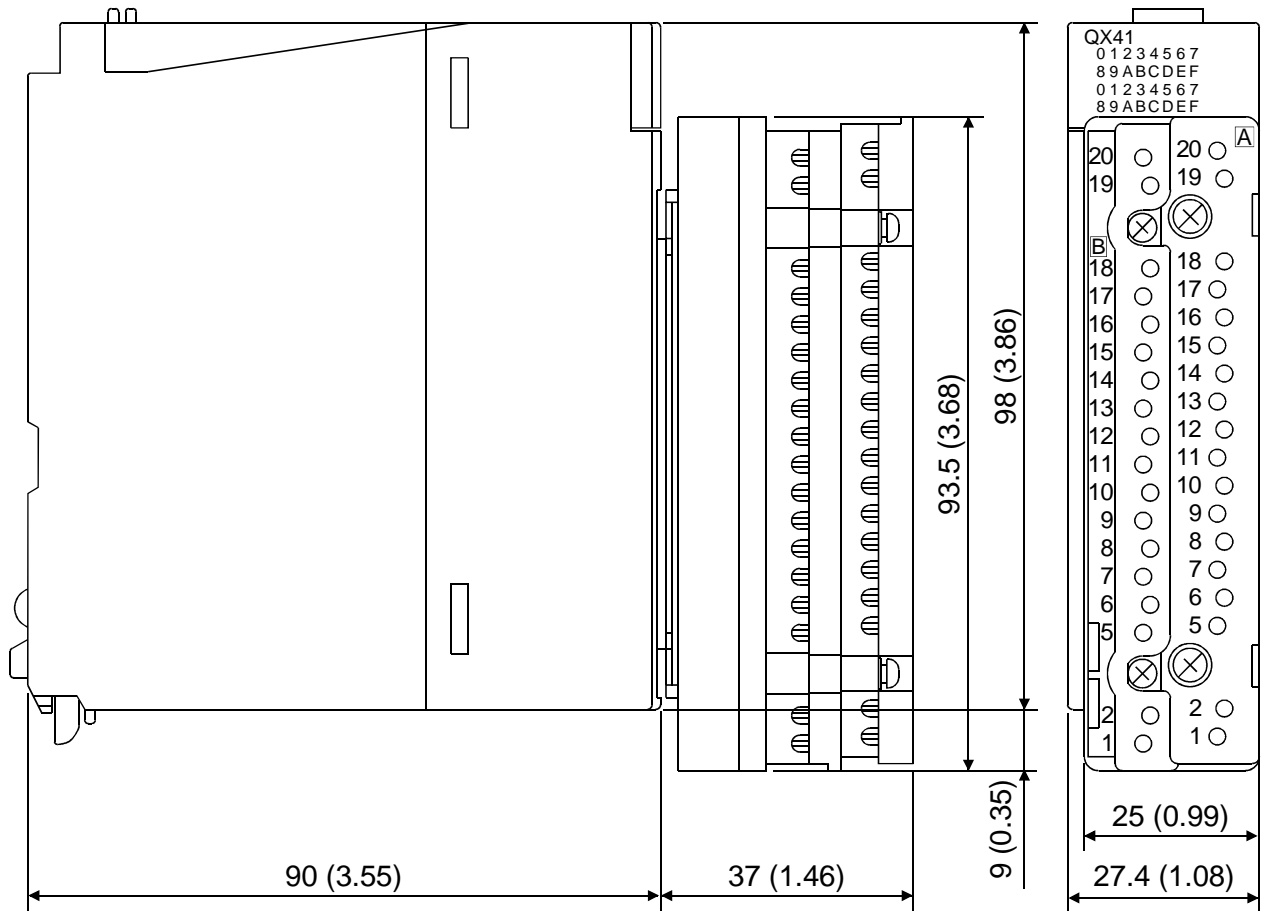

(2) Q6TA32-TOL

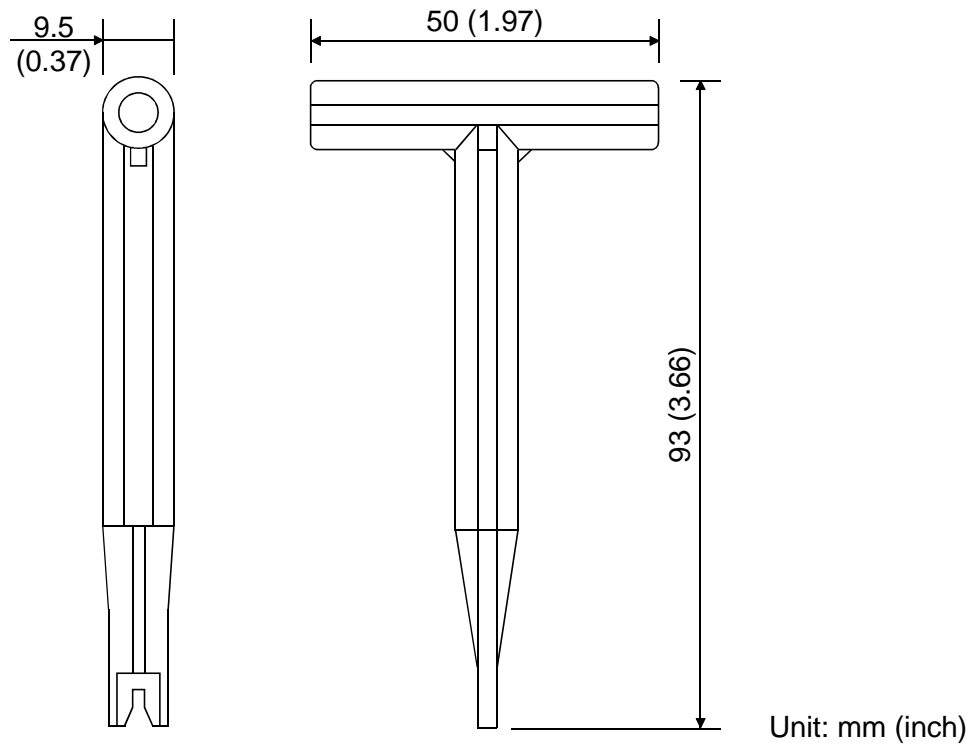

## Warranty

Mitsubishi will not be held liable for damage caused by factors found not to be the cause of Mitsubishi; machine damage or lost profits caused by faults in the Mitsubishi products; damage, secondary damage, accident compensation caused by special factors unpredictable by Mitsubishi; damages to products other than Mitsubishi products; and to other duties.

### ⚠ For safe use

- This product has been manufactured as a general-purpose part for general industries, and has not been designed or manufactured to be incorporated in a device or system used in purposes related to human life.
- Before using the product for special purposes such as nuclear power, electric power, aerospace, medicine or passenger movement vehicles, consult with Mitsubishi.
- This product has been manufactured under strict quality control. However, when installing the product where major accidents or losses could occur if the product fails, install appropriate backup or failsafe functions in the system.

Country/Region	Sales office/Tel	Country/Region	Sales office/Tel
U.S.A	Mitsubishi Electric Automation Inc. 500 Corporate Woods Parkway Vernon Hills, IL 60061 Tel : +1-847-478-2100	Hong Kong	Ryoden Automation Ltd. 10th Floor, Manulife Tower, 169 Electric Road, North Point, HongKong Tel : +852-2887-8870
Brazil	MELCO-TEC Rep. Com.e Assessoria Tecnica Ltda. AV. Paulista 1471, Conj. 308, Sao Paulo City, Sao Paulo State, Brazil Tel : +55-11-283-2423	China	Ryoden Automation Shanghai Ltd. 3F Block5 Building Automation Instrumentation Plaza 103 Cao Bao Rd. Shanghai 200233 China Tel : +86-21-6475-3228
Germany	Mitsubishi Electric Europe B.V. German Branch Gothaer Strasse 8 D-40880 Ratingen, GERMANY Tel : +49-2102-486-0	Taiwan	Setsuyo Enterprise Co., Ltd. 6F., No.105 Wu-Kung 3rd.RD, Wu-Ku Hsiang, Taipei Hsine, Taiwan Tel : +886-2-2299-2499
U.K	Mitsubishi Electric Europe B.V. UK Branch Travellers Lane, Hatfield, Herts., AL10 8XB,UK Tel : +44-1707-276100	Korea	HAN NEUNG TECHNO CO.,LTD. 1F Dong Seo Game Channel Bldg., 660-11, Deungchon-dong Kangsec-ku, Seoul, Korea Tel : +82-2-3660-9552
Italy	Mitsubishi Electric Europe B.V. Italian Branch Centro Dir. Colleoni, Pal. Perseo-Ingr.2 Via Paracelso 12, 20041 Agrate B., Milano, Italy Tel : +39-039-6053344	Singapore	Mitsubishi Electric Asia Pte, Ltd. 307 ALEXANDRA ROAD #05-01/02, MITSUBISHI ELECTRIC BUILDING SINGAPORE 159943 Tel : +65-6473-2308
Spain	Mitsubishi Electric Europe B.V. Spanish Branch Carretera de Rubi 76-80 08190 - Sant Cugat del Valles, Barcelona, Spain Tel : +34-93-565-3131	Thailand	F. A. Tech Co.,Ltd. 898/28,29,30 S.V.City Building,Office Tower 2,Floor 17-18 Rama 3 Road, Bangkpongpan, Yannawa, Bangkok 10120 Tel : +66-2-682-6522
France	Mitsubishi Electric Europe B.V. French Branch 25 Boulevard des Bouvets, F-92741 Nanterre Cedex, France TEL: +33-1-5568-5568	Indonesia	P.T. Autoteknindo SUMBER MAKMUR Jl. Muara Karang Selatan Block A Utara No.1 Kav. No.11 Kawasan Industri/ Pergudangan Jakarta - Utara 14440 Tel : +62-21-663-0833
South Africa	Circuit Breaker Industries LTD. Tripswitch Drive, Elandsfontein Gauteng, South Africa Tel : +27-11-928-2000	India	Messung Systems Put,Ltd. Electronic Sadan NO:111 Unit No15, M.I.D.C BHOSARI,PUNE-411026 Tel : +91-20-712-2807
		Australia	Mitsubishi Electric Australia Pty. Ltd. 348 Victoria Road, PostalBag, No 2, Rydalmere, N.S.W 2116, Australia Tel : +61-2-9684-7777



## MITSUBISHI ELECTRIC CORPORATION

HEAD OFFICE : 1-8-12, OFFICE TOWER Z 14F HARUMI CHUO-KU 104-6212, JAPAN  
NAGOYA WORKS : 1-14, YADA-MINAMI5, HIGASHI-KU, NAGOYA, JAPAN

When exported from Japan, this manual does not require application to the Ministry of Economy, Trade and Industry for service transaction permission.

Specifications subject to change without notice.  
Printed in Japan on recycled paper.