

GX Developer Version 8

Operating Manual

(Special Functions for Overseas)

mitsubishi

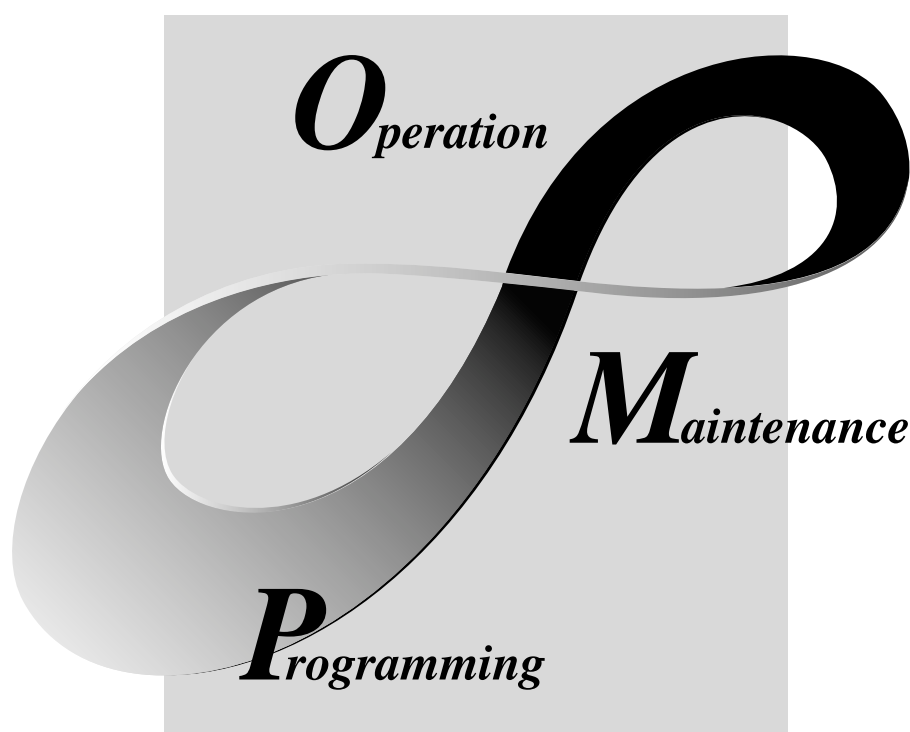

MELSOFT
Integrated FA Software

SW8D5C-GPPW-E

• SAFETY PRECAUTIONS •

(Always read these instructions before using this equipment.)

Before using this product, please read this manual and the relevant manuals introduced in this manual carefully and pay full attention to safety to handle the product correctly.

The instructions given in this manual are concerned with this product. For the safety instructions of the programmable controller system, please read the CPU module user's manual.

In this manual, the safety instructions are ranked as "DANGER" and "CAUTION".



Indicates that incorrect handling may cause hazardous conditions, resulting in death or severe injury.



Indicates that incorrect handling may cause hazardous conditions, resulting in medium or slight personal injury or physical damage.

Note that the  CAUTION level may lead to a serious consequence according to the circumstances. Always follow the instructions of both levels because they are important to personal safety.

Please save this manual to make it accessible when required and always forward it to the end user.

[Design Instructions]

DANGER

- When data change, program change or status control is to be made from a personal computer to the running programmable controller CPU, configure up an interlock circuit in the outside of the programmable controller system to ensure that the whole system will always operate safely. Also, determine corrective actions to be taken for the system when a communication error occurs due to a cable connection fault or the like in online operation performed from the personal computer to the programmable controller CPU.

CAUTION

- Online operation performed with a personal computer connected to the running CPU module (especially program change, forced output or operating status change) should be started after carefully reading the manual and fully ensuring safety. Not doing so can cause machine damage or accident due to miss operation.

REVISIONS

* The manual number is given on the bottom left of the back cover.

Print Date	* Manual Number	Revision
Jan., 2008	SH(NA)-080760ENG-A	First edition

This manual confers no industrial property rights or any rights of any other kind, nor does it confer any patent licenses. Mitsubishi Electric Corporation cannot be held responsible for any problems involving industrial property rights which may occur as a result of using the contents noted in this manual.

© 2008 MITSUBISHI ELECTRIC CORPORATION

INTRODUCTION

Thank you for choosing the Mitsubishi MELSOFT series Integrated FA software.
Read this manual and make sure you understand the functions and performance of MELSEC series programmable controller thoroughly in advance to ensure correct use.
Please make this manual available to the end user.

CONTENTS

SAFETY PRECAUTIONS.....	A- 1
REVISIONS	A- 2
INTRODUCTION.....	A- 3
CONTENTS.....	A- 3
Manuals	A- 4
How the manual describes the explanation is shown below	A- 5
Abbreviations and Terms in This Manual.....	A- 7
1. GENERAL DESCRIPTION	1- 1 to 1- 3
1.1 Features	1- 1
1.2 Function List.....	1- 3
2. SYSTEM CONFIGURATION	2- 1 to 2- 2
2.1 Connecting from the Serial Port	2- 1
2.2 System Equipment.....	2- 1
3. ACCESSING TO SX Controller	3- 1 to 3- 4
3.1 Accessing from Personal Computer.....	3- 2
3.2 Accessing from GX Developer that Operates on PC CPU Module	3- 4
4. MXChange CONVERSION FUNCTIONS	4- 1 to 4- 15
4.1 Function List	4- 1
4.2 General Procedure for Using the MXChange Conversion Functions	4- 3
4.3 Logging in to the Server.....	4- 4
4.4 Logging off the Server.....	4- 6
4.5 MXChange Data Base Conversion	4- 7
4.6 Importing from MXChange Tags	4- 9
4.7 Exporting to MXChange Tags	4-11
4.8 MXChange Troubleshooting.....	4-15
APPENDIX	App- 1 to App- 4
Appendix 1 Restrictions on Using SX Controller.....	App- 1
Appendix 2 Accessing to MAC	App- 2
Appendix 3 Restrictions When Changing CPU Types.....	App- 3

Manuals

The following lists the manuals for this software package.

Refer to the following table when ordering manuals.

Related Manuals

Manual Name	Manual Number (Model Code)
GX Developer Version 8 Operating Manual Explains the online functions of GX Developer, such as the programming, printout, monitoring and debugging methods.	SH-080373E (13JU41)
GX Developer Version 8 Operating Manual (Startup) Describes the system configuration, installation method and start-up procedure of GX Developer.	SH-080372E (13JU40)

REMARKS

Manuals in printed form are sold separately for single purchase.
Order a manual by quoting the manual number (model code) listed in the table above.

How the manual describes the explanation is shown below

4.6 Importing from MXChange Tags

A	Q/QnA	QS	FX
○	○	×	○

○: The function is available.
 ×: The function is unavailable.

[Purpose]
 Reads comment data in the MXChange server.

[Operating Procedure]
 Select [Project] → [Import file] → [Import from MXChange tags].

[Dialog Box]

[Description]

- 1) MXChange : Project Node
 Set the MELSEC project node.
 Set the item from the button.
- 2) GX Developer Project : Data name
 Select from the displayed data names that exist in the currently opened GX Developer project.





POINT

- When importing the MXChange tag (64 characters) to GX Developer, the first 8 characters of the MXChange data are read to the GX Developer Alias.
- When importing the comment (64 characters) of the MXChange tag to GX Developer, the first 32 characters of the MXChange data are read to the GX Developer comment.

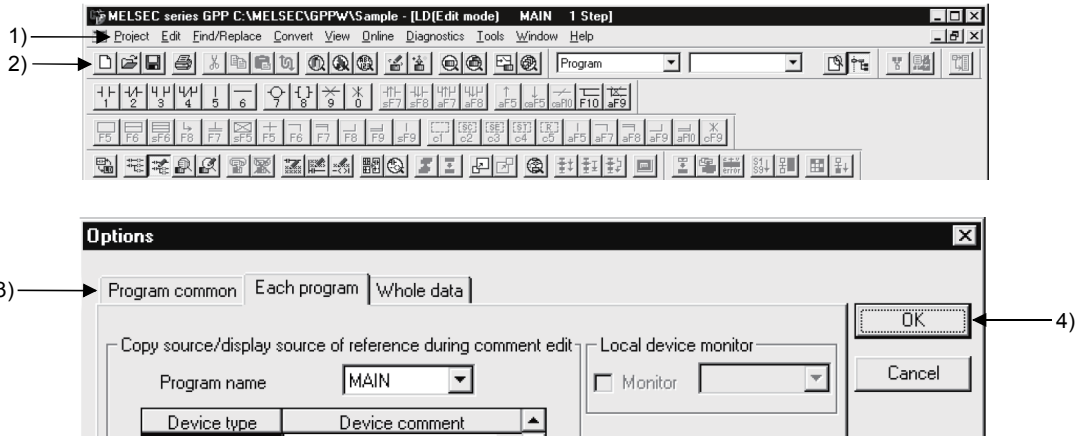
This gives the information related to the topic discussed and also the helpful information.

Symbols used in this manual, and the contents and examples of them are shown below.

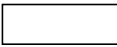

No.	Symbol	Contents	Example
1)	[]	Menu name of menu bar	[Project]
2)		Icon in toolbar	
3)	<< >>	Tab name of dialog box	<<Program common>>
4)		Command button in dialog box	 button

Abbreviations and Terms in This Manual

This manual uses the abbreviations and terms listed in the following table to discuss the GX Developer software package and programmable controller CPU module. In addition, the following table lists the names of modules whose names must be indicated explicitly.

Abbreviation/Generic term	Description/Target module
GX Developer	Generic product name of the product types SW8D5C-GPPW-E, SW8D5C-GPPW-EA, SW8D5C-GPPW-EV and SW8D5C-GPPW-EVA.
GX Developer Version n (SWnD5C-GPPW-E)	When limited to the major version (n denotes the version number).
GX Developer Version n (SWnD5C-GPPW-E) or earlier	When limited to earlier than the major version (n denotes the version number).
GX Developer Version n (SWnD5C-GPPW-E) or later	When limited to later than the major version (n denotes the version number).
ACPU	Generic term for programmable controller CPU available with MELSEC-A. Including MOTION (SCPU). (However, GX Developer does not support A1, A2, A3, A3H, A3M, A52G, A73, A0J2 and A3V.)
QCPU (A mode)	Generic term for Q02(H)-A and Q06H-A.
QnACPU	Generic term for programmable controller CPU available with MELSEC-QnA.
QCPU (Q mode)	Generic term for Q00J, Q00, Q01, Q02(H), Q02U, Q03UD, Q04UDH, Q06H, Q06UDH, Q12H, Q12PH, Q12PRH, Q25H, Q25PH and Q25PRHCPU.
QSCPU	Abbreviation for a safety CPU module (QS001CPU).
FXCPU	Generic term for programmable controller CPU available with MELSEC-F. (The target programmable controller CPUs are FX ₀ , FX _{0s} , FX _{0N} , FX ₁ , FX, FX ₂ , FX _{2c} , FX _{1s} , FX _{1N} , FX _{2N} , FX _{2NC} , FX _{3U} and FX _{3UC} .)
A series	For GX Developer CPU type selection by ACPUs.
QnA series	For GX Developer CPU type selection by QnACPU.
Q series	For GX Developer CPU type selection by QCPU (Q mode).
FX series	For GX Developer CPU type selection by FXCPU.
A6TEL	A6TEL modem interface module
Q6TEL	Q6TEL modem interface module
GOT	Generic term for Mitsubishi Graphic Operation Terminal GOT1000 series, GOT-A900 series and GOT-F900 series.
SX Controller	Generic product name of the product types SWnPNC-Q25SS-E. (n denotes the version number)

1. GENERAL DESCRIPTION

1

This manual explains the special functions of GX Developer designed exclusively for overseas use.

1.1 Features

The following explains the features of GX Developer designed exclusively for overseas use.

(1) Accessibility to SX Controller

SX Controller is software designed to operate on a PC CPU module.

By executing the program written with GX Developer, SX Controller makes Q bus access and achieves sequence control using the device data that the software itself has.

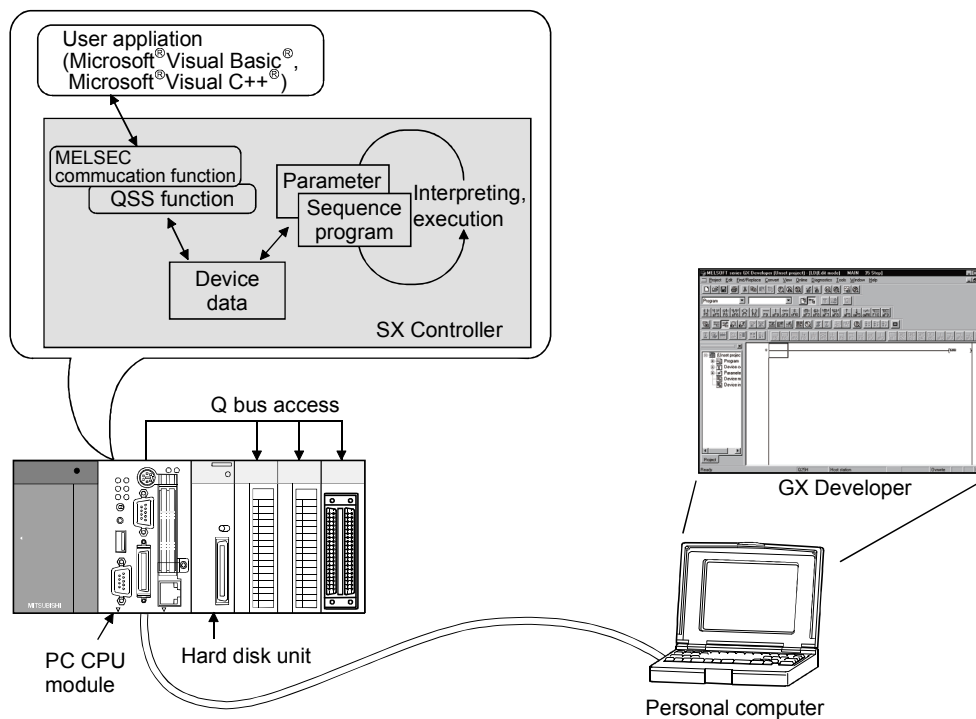

(2) Featured with the MXChange conversion functions

Device comment data created in the GX Developer project can be shared with other applications by using the MXChange conversion functions.

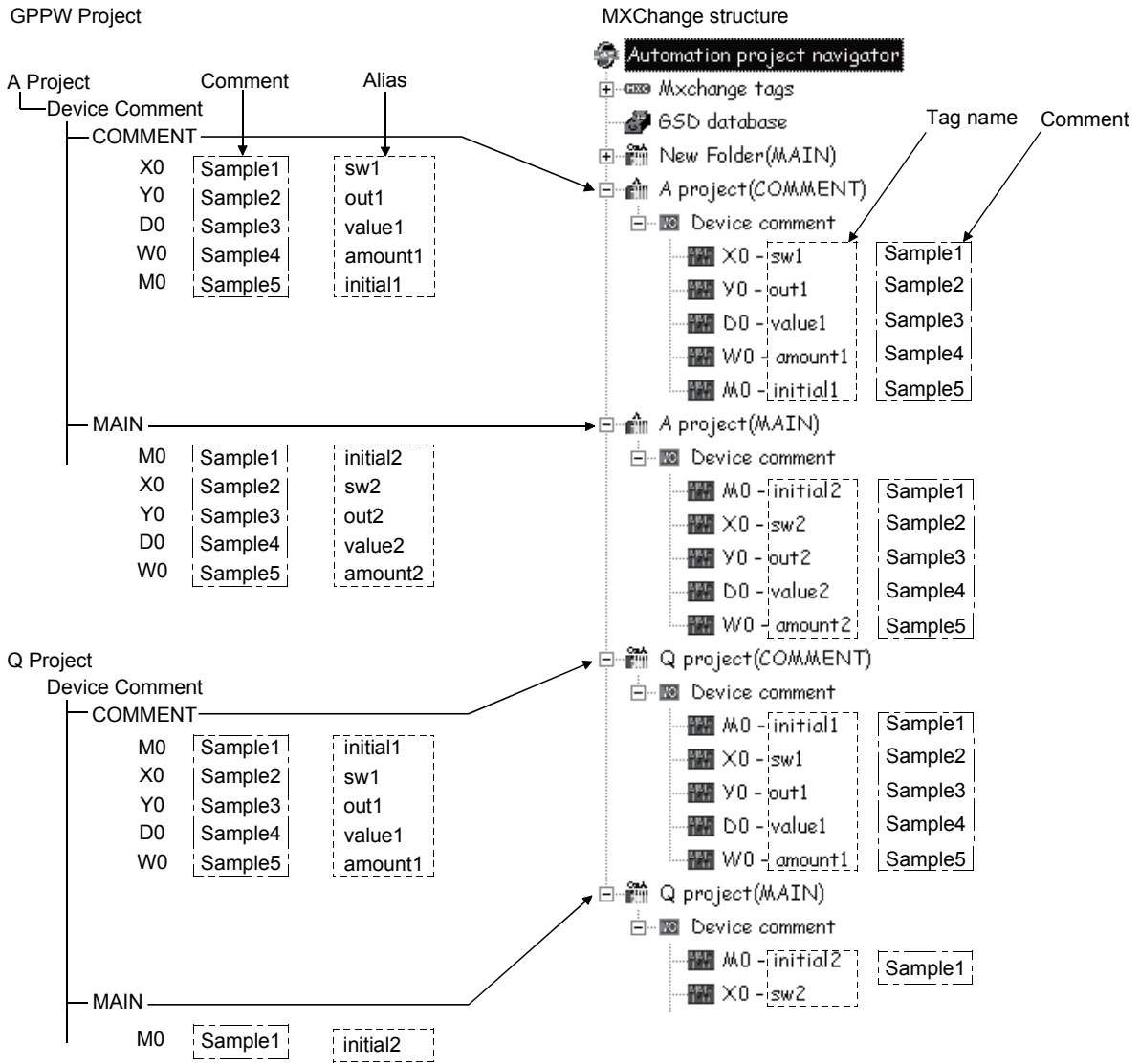

(3) Accessibility to MAC

MAC can be accessed by using the RS-232C serial communications.

1.2 Function List

The following table shows the function menus for GX Developer designed exclusively for overseas use.

Tool (Common functions)		Only for monitoring	Reference
MXChange actions			
Log in	Log in to MXChange Server.		4.3
Log out	Log off MXChange Server.		4.4
Change Password	Changes password in MXChange Server.	○	4.3

2. SYSTEM CONFIGURATION

The following figure shows the system configuration of GX Developer designed exclusively for overseas use.

2.1 Connecting from the Serial Port

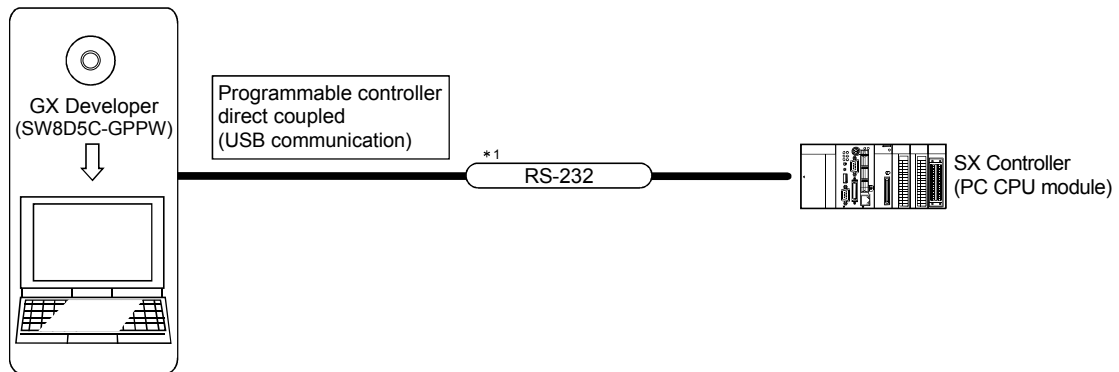

*1: PC CPU module compatible RS-232 cable

PC CPU module side		Cable connection and signal direction	Personal computer
Signal name	Pin No.		Signal name
CD	1		CD
RD(RXD)	2		RD(RXD)
SD(TXD)	3		SD(TXD)
DTR(ER)	4		DTR(ER)
SG	5		SG
DSR(DR)	6		DSR(DR)
RS(RTS)	7		RS(RTS)
CS(CTS)	8		CS(CTS)

2.2 System Equipment

The following table shows the module that can be accessed to/from GX Developer designed exclusively for overseas use.

Programmable controller CPU series	Module name	Module model
Q series	Programmable controller CPU module	Q25SS

3. ACCESSING TO SX Controller

A	Q/QnA	QS	FX
x	○*	x	x

*: Compatible with the Q25SS.

This chapter explains the method for accessing to the SX Controller from the personal computer and GX Developer that operates on a PC CPU module.

Accessing from personal computer

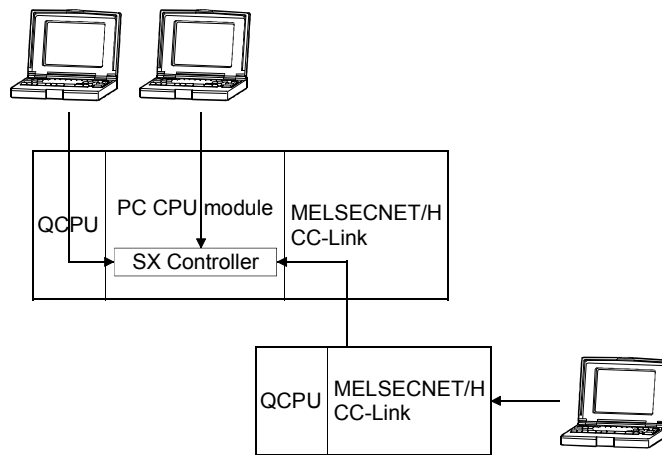

Accessing from GX Developer that operates on PC CPU module

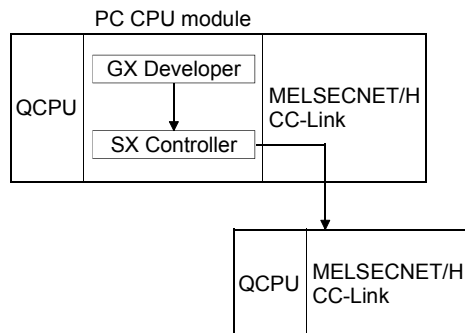

3.1 Accessing from Personal Computer

A	Q/QnA	QS	FX
×	○*	×	×

*: Compatible with the Q25SS.

[Purpose]

For the access to the SX Controller, connection can be made in any of the following routes.

- 1) Connect through the QCPU (Q mode) module
- 2) Connect from a personal computer to the SX Controller
- 3) Connect via MELSECNET/H or CC-Link on another station

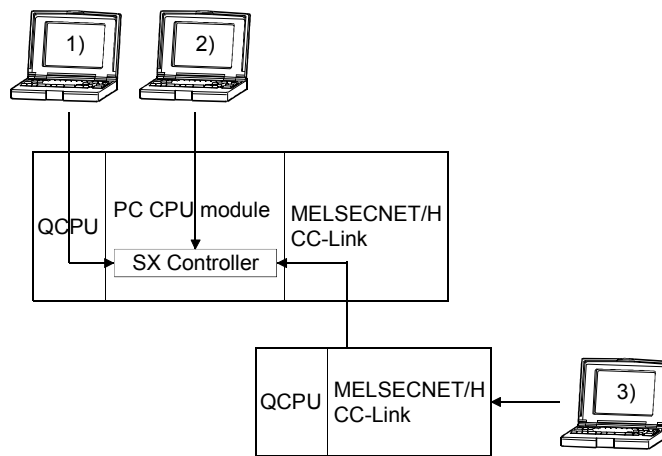

[Operating Procedure]

Select [Online] → [Connection setup].

[Dialog Box]

When the personal computer is connected to the RS-232 port of the PC CPU module (In the case of 2))

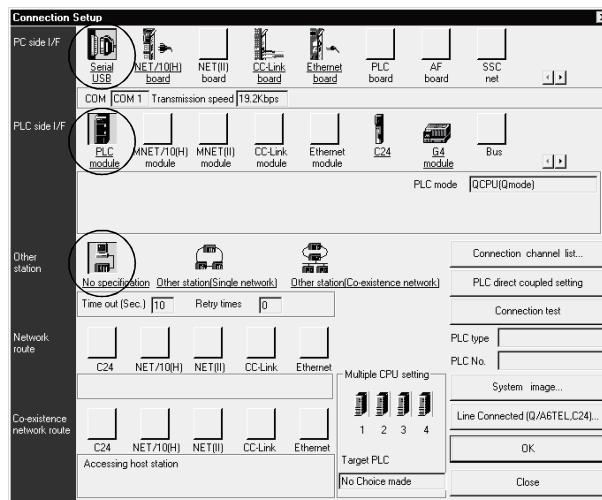

[Description]

- For "PC side I/F", select the port, interface board or the like used with the personal computer.
- For "PLC side I/F", select the module to be connected to the personal computer.
- Refer to the GX Developer Operating Manual for setting "Other station", "Network route", and "Co-existence network route".
- You cannot select the following route.

You cannot select the Q-compatible C24 or Q-compatible E71 route of the module controlled by the SX Controller.

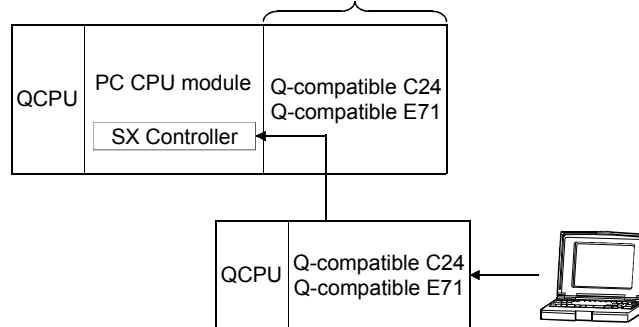

3.2 Accessing from GX Developer that Operates on PC CPU Module

A	Q/QnA	QS	FX
×	○*	×	×

*: Compatible with the Q25SS.

[Purpose]

When GX Developer is installed in the PC CPU module, data can be accessed to the SX Controller or to another station through SX Controller via MELSECNET/H or CC-Link.

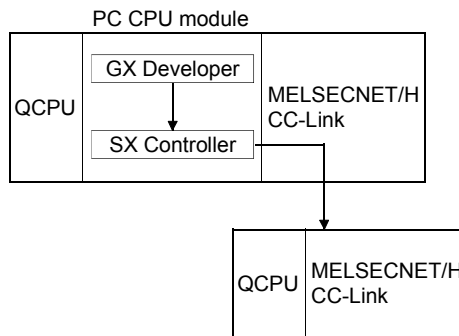

[Operating Procedure]

Select [Online] → [Connection setup].

[Dialog Box]

When accessing to another station through SX Controller via MELSECNET/H

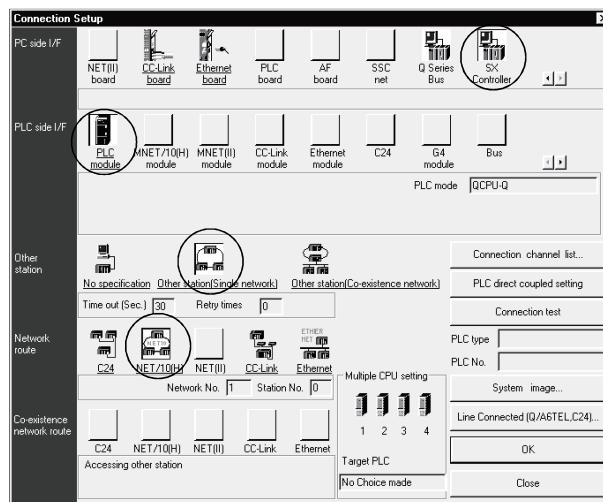

[Description]

You cannot select the Q-compatible C24 or Q-compatible E71 route of the module controlled by the SX Controller.

4. MXChange CONVERSION FUNCTIONS

The MXChange conversion functions are designed to share the device comment data of GX Developer project among applications. Programs, device memory and others cannot be converted.

4.1 Function List

A	Q/QnA	QS	FX
○	○	×	○

The following functions can be performed on GX Developer.

Function	Description
MXChange data base → GX Developer device comment read	The tag information of the MXChange data base is read onto GX Developer and converted into GX Developer device comments. (Refer to Section 4.6)
MXChange data base ← GX Developer device comment write	GX Developer device comments are converted into the tag information of the MXChange data base and the results are written to the MXChange data base. (Refer to Section 4.7)
MXChange server designation	Among multiple MXChange data bases, specify the data base server which reads/writes the device comment data of GX Developer. (Refer to Section 4.3)
Tag change notice	When the MXChange data base is updated from another application, it can be confirmed that the tag information has been changed. (Refer to Section 4.3)
Password setting	Set the password used when you log in to the MXChange server. (Refer to Section 4.3)

4

The following table lists the devices supported.

For MXChange 1.1b

- Bit devices

	M	SM	Special M	S	L	F	V	X	Y	B	SB	DX	DY	BL
QCPU (Q mode)	○	○	×	×	○	○	○	○	○	○	○	○	○	×
QnACPU	○	○	×	×	○	○	○	○	○	○	○	○	○	×
ACPU	○	×	○	○	○	×	×	○	○	○	×	×	×	×
FXCPU	○	×	○	○	×	×	×	○	○	×	×	×	×	×

- Word devices

	D	SD	Special D	R	ZR	W	SW	T	C	ST	P	I	U	J
QCPU (Q mode)	○	○	×	○	○	○	○	○	○	○	○	○	×	×
QnACPU	○	○	×	○	○	○	○	○	○	○	○	○	×	×
ACPU	○	×	○	○	×	○	×	○	○	×	○	○	×	×
FXCPU	○	×	○	×	×	×	×	○	○	×	○	○	×	×

For MXChange 2.1

• Bit devices

	M	SM	Special M	S	L	F	V	X	Y	B	SB	DX	DY	BL
Q02(H)/Q06/ Q12H/Q25HCPU	○	○	×	×	○	○	○	○	○	○	○	○	○	×
Q00J/Q00/ Q01CPU	○	○	×	×	○	○	○	○	○	○	○	○	○	×
QnACPU	○	○	×	×	○	○	○	○	○	○	○	○	○	×
ACPU	○	×	○	○	○	×	×	○	○	○	×	×	×	×
FXCPU	○	×	○	○	×	×	×	○	○	×	×	×	×	×

• Word devices

	D	SD	Special D	R	ZR	W	SW	T	C	ST	P	I	U	J
Q02(H)/Q06/ Q12H/Q25HCPU	○	○	×	○	○	○	○	○	○	○	○	○	×	×
Q00J/Q00/ Q01CPU	○	○	×	○*1	○*1	○	○	○	○	○	○	○	×	×
QnACPU	○	○	×	○	○	○	○	○	○	○	○	○	×	×
ACPU	○	×	○	○	×	○	×	○	○	×	○	○	×	×
FXCPU	○	×	○	×	×	×	×	○	○	×	○	○	×	×

*1: R and ZR cannot be used for the Q00JCPU.

4.2 General Procedure for Using the MXChange Conversion Functions

A	Q/QnA	QS	FX
○	○	×	○

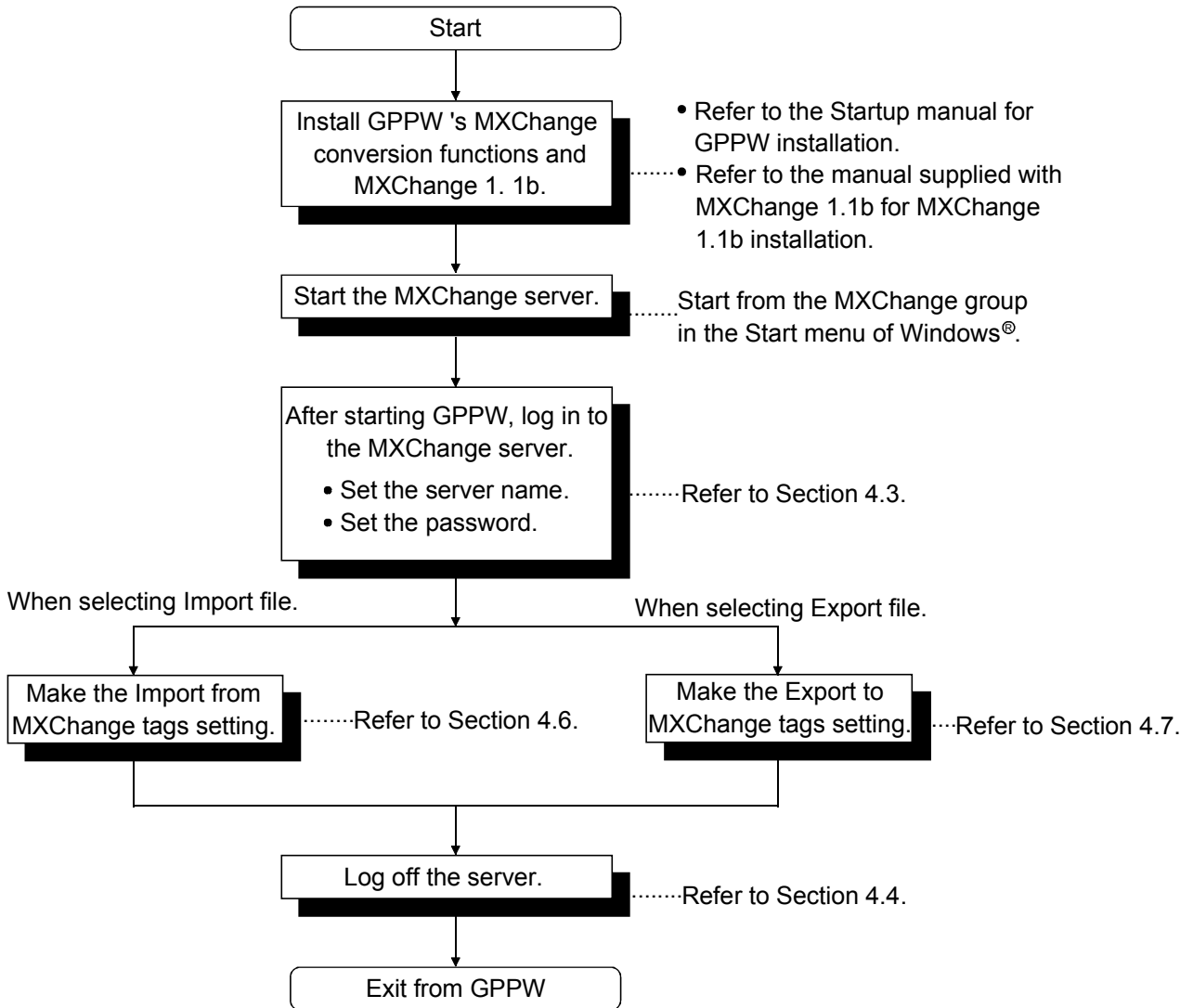

4.3 Logging in to the Server

A	Q/QnA	QS	FX
○	○	×	○

[Purpose]

Enables use of the MXChange data base conversion functions.

Menu selection cannot be made unless the project is open on GX Developer.

[Operating Procedure]

Select [Tool] → [MXChange actions] → [Login].

[Dialog Box]

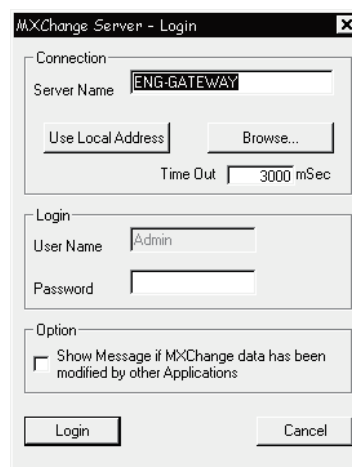

[Description]

- 1) **Server Name**
Type the MXChange server name (or IP address) to which GX Developer is connected.
- 2) **Use Local Address** button
The computer name in current use is set as the Server Name.
- 3) **Browse** button
A connectable server list is displayed.
Select the Server Name and click the **Select** button.
- 4) **Time Out**
Set the time-out value when making connection to the server.
The range setting is 0 to 200000ms.
- 5) **User Name**
Defaults to Admin.
The User Name cannot be changed.

6) Password

Set the password (max. 1024 characters) used when making connection to the server with the specified login name.

How to set the password change.

1. Select [Tool] → [MXChange actions] → [Password].
2. In "Old Password", set the password currently used.
In "New Password" and "Retype", set a new password.
3. Click the **OK** button.

7) Option

When any change has been made to the data of the MXChange data base, GX Developer receives that change and you can confirm it in the following dialog box.

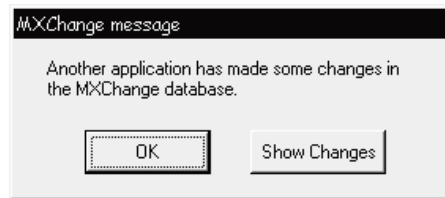

Clicking the **Show Changes** button displays the following screen.

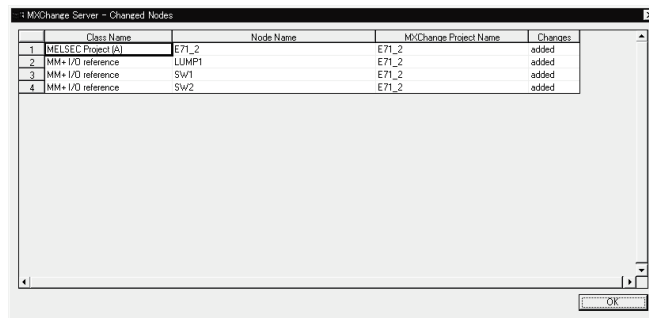

Item	Description
Class Name	Any of the following is displayed. When changes were made to the project node: <ul style="list-style-type: none"> • MELSEC project (A) • MELSEC project (Q) • MELSEC project (FX) • MELSEC project (QnA) • MELSEC project (Motion) When changes were made to the tag: <ul style="list-style-type: none"> • MM+ I/O Reference
Node Name	Displays node names of GX Developer that are changed.
MXChange Project Name	Displays project names that are changed.
Changes	Any of the following is displayed. <ul style="list-style-type: none"> • deleted: The displayed node or tag was erased from another application. • modified: Comment data of the displayed node or tag that was erased from another application are changed. • added: Additions were made to the displayed node or tag from another application.

4.4 Logging off the Server

A	Q/QnA	QS	FX
○	○	×	○

[Purpose]

Stops connection to the MXChange server.

[Operating Procedure]

Select [Tool] → [MXChange actions] → [Logoff].

4.5 MXChange Data Base Conversion

A	Q/QnA	QS	FX
○	○	×	○

This section explains correspondences between the GX Developer project data and MXChange data base data for execution of MXChange data base conversion.

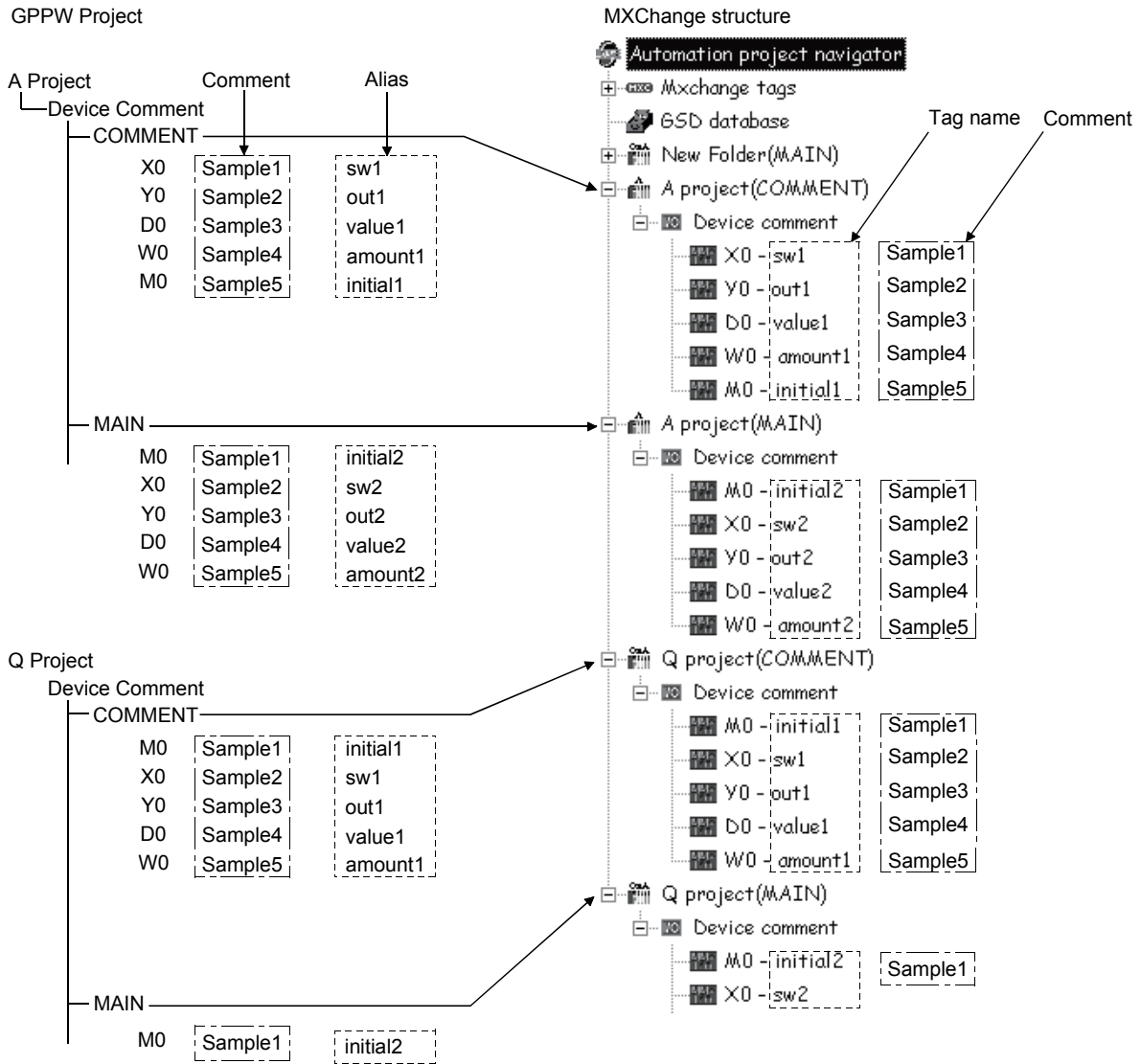

In the MXChange data base, the comment types of the GX Developer device comments correspond to the respective project nodes (FX Project (COMMENT), Q Project (MAIN), etc.).

For importing data from MXChange server to GX Developer, the data names correspond as indicated below.

MXChange tag		GX Developer Project
Tag name	→	Alias
Device	→	Device
Comment	→	Comment

For exporting data from GX Developer to MXChange server, the data names correspond as indicated below.

GX Developer Project		MXChange tag
Device	→	Device
Comment	→	Comment
Label	→	Tag name

POINT
<ul style="list-style-type: none"> • When the Alias created on GX Developer is exported to the MXChange data base, do not use any characters other than the alphabets, numerals and "_". In addition, do not enter a space or numeral at the beginning of the Label. • If nothing has been set to the Alias of GX Developer at the time of Export, Device changes to Tag name.

4.6 Importing from MXChange Tags

A	Q/QnA	QS	FX
○	○	×	○

[Purpose]

Reads comment data in the MXChange server.

[Operating Procedure]

Select [Project] → [Import file] → [Import from MXChange tags].

[Dialog Box]

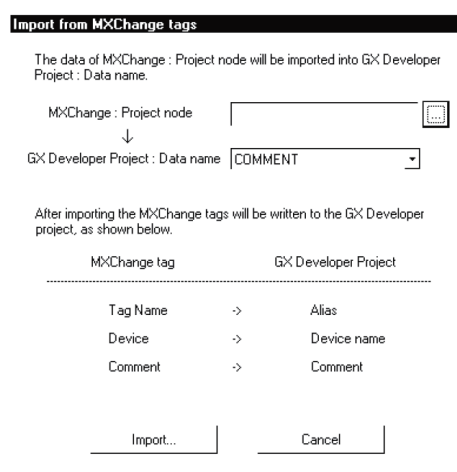

[Description]

- 1) MXChange : Project Node
Set the MELSEC project node.
Set the item from the  button.
- 2) GX Developer Project : Data name
Select from the displayed data names that exist in the currently opened GX Developer project.

3) **Import** button

Deletes all comment data exist on GX Developer and reads comment data from the MXChange server to GX Developer.

The following dialog box appears if the same data (device number) exist in the devices within the imported tag.

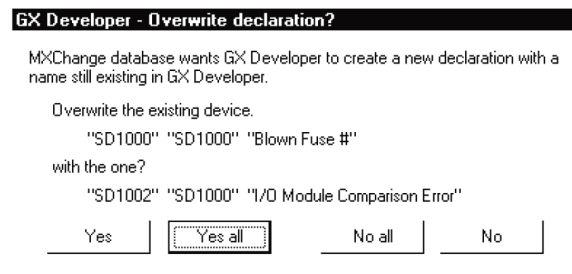

Yes :Replaces the device comment displayed in "Overwrite the existing declaration" with the data displayed in "with the new one".

Yes all :Replaces all data with the newly read data.

No all :Does not replace data if the tag name read from MXChange exists in the Alias of the GX Developer comment data.

No :Does not replace the device comment displayed in "Overwrite the existing declaration" with the data displayed in "with the new one".

Selecting **Yes** or **Yes all** performs the following process.

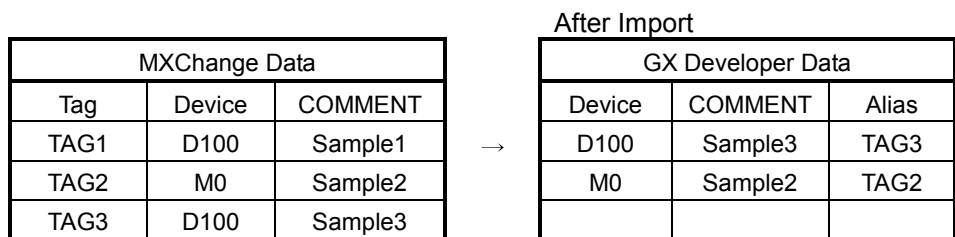

TAG1 D100 Sample1 is overwritten by TAG3 D100 Sample3.

When importing the MXChange data different in CPU type on GX Developer, the data within the CPU type range of the GX Developer project is imported.

POINT

- When importing the MXChange tag (64 characters) to GX Developer, the first 8 characters of the MXChange data are read to the GX Developer Alias.
- When importing the comment (64 characters) of the MXChange tag to GX Developer, the first 32 characters of the MXChange data are read to the GX Developer comment.

4.7 Exporting to MXChange Tags

A	Q/QnA	QS	FX
<input type="radio"/>	<input type="radio"/>	<input checked="" type="radio"/>	<input type="radio"/>

[Purpose]

Writes the device comments and Alias created on GX Developer to the MXChange data base server.

[Operating Procedure]

Select [Project] → [Export file] → [Export to MXChange tags].

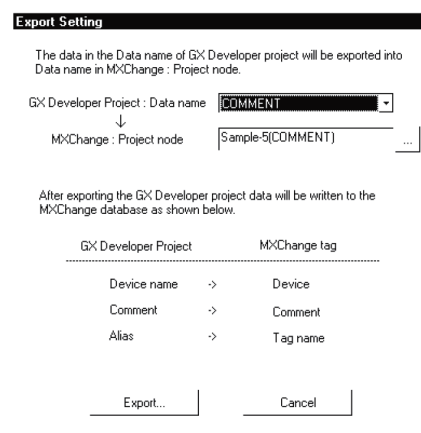
[Dialog Box]**[Description]**

- 1) GX Developer Project : Data name
Displays the data name of the project currently edited.
Set the data name to be written to the MELSEC data base.
- 2) MXChange : Project node
Set the MELSEC project node at the export destination of MXChange.
When selecting the existing project node, setting can be made from the  button.

3) **Export** button

Converts the comment data of the MXChange data base.

The following dialog box appears if the MELSEC project node set on the Export Settings screen does not exist.

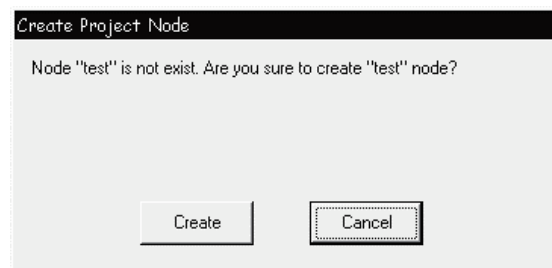

Clicking the **Create** button creates a new MXChange node (MELSEC project node, comment node) with the input node name.

The following dialog box appears if the CPU type set for the selected project node differs from the CPU type of the GX Developer project to be exported. Perform operation in accordance with the message of the following dialog box.

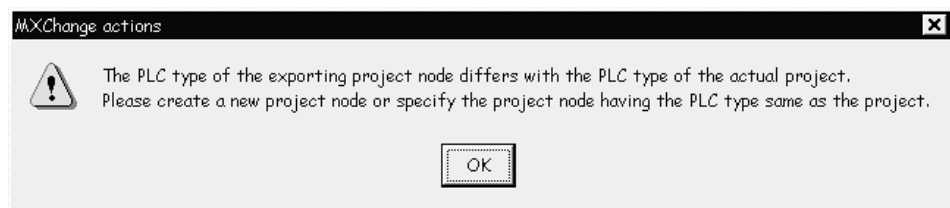

The following dialog box appears if the Alias of the GX Developer project includes any character other than the alphabets, numerals and "_" or if the first character is a space or numeral.

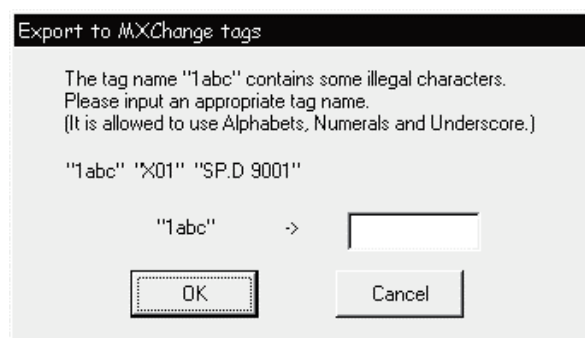

The following dialog box appears if the same tag name already exists in the MXChange data base or if overlapping data exist in the device comments or aliases of GX Developer.

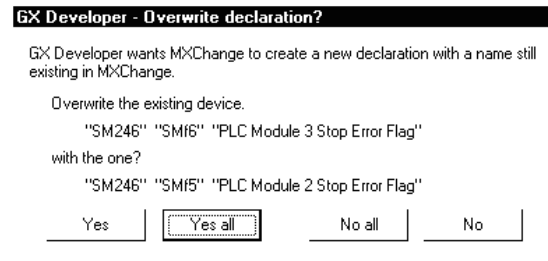

- Yes** :Replaces the tag displayed in "Overwrite the existing declaration" with the tag displayed in "with the new one".
- Yes all** :Replaces all data with new data.
- No all** :Does not replace data if the same tag name exists at the write destination.
- No** :Does not replace the tag displayed in "Overwrite the existing declaration" with the tag displayed in "with the new one".

Selecting **Yes** or **Yes all** performs the following process.

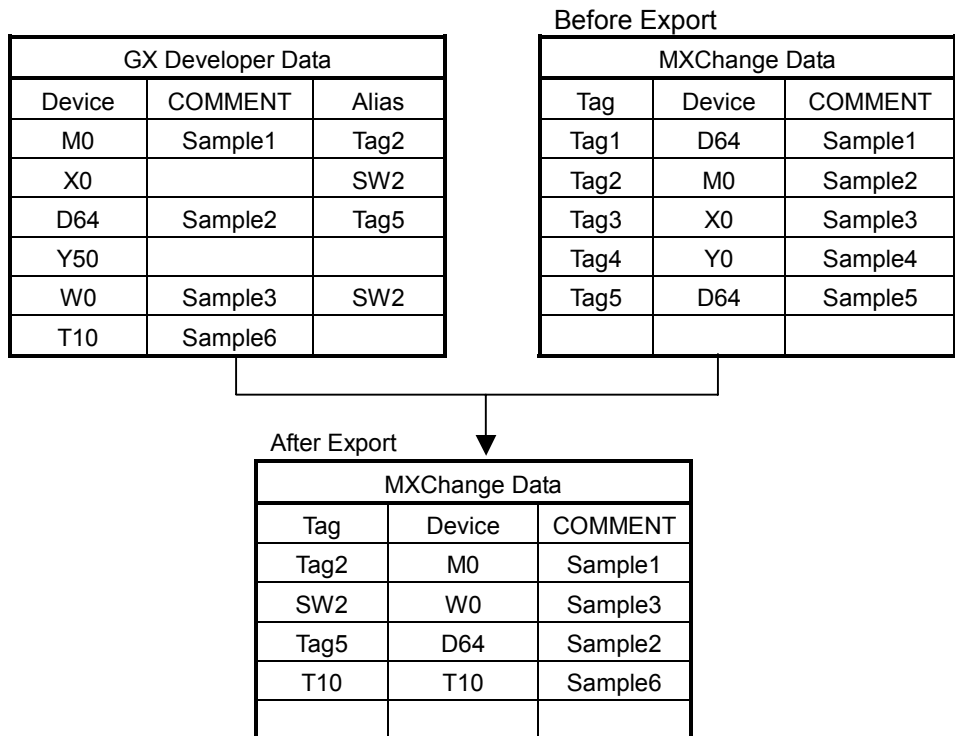

- Y50 of GX Developer is not exported since it has no COMMENT and Alias.
- If there is no data set in Alias of GX Developer at the time of Export, the device changes to the tag name.

Exporting the data in the preceding table shows the following dialog box. The following dialog box appears since Tag5 D64 Sample2 exists in the GX Developer data and Tag5 D64 Sample5 exists in the MXChange data.

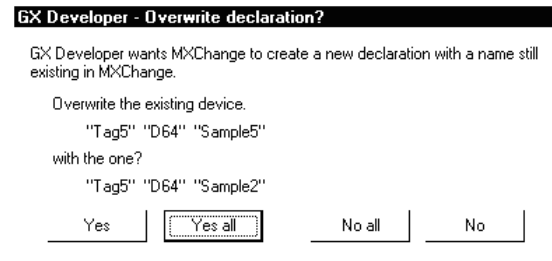

Since more than one SW2 exists as the Alias of the GX Developer data, the following dialog box appears.

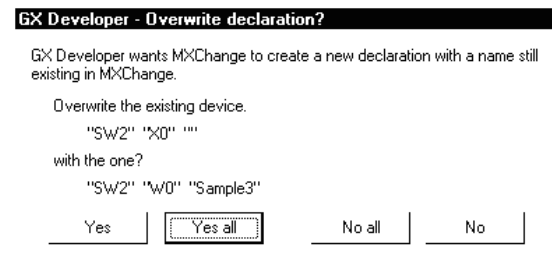

4.8 MXChange Troubleshooting

The following table shows error messages and their corrective actions.

Error message	Corrective action
"The connection to the MXChange server timed out!"	Increase the time-out value in the Login dialog box.
"The MXChange server has been disconnected!"	Start the MXChange server or log in again.
"Not logged in, or insufficient right to perform the action!"	Type the password correctly.
"Logoff incorrect! confirmed (error code number)"	Make sure that the server has been started. Inform the developer of the error code.
"Close Connection unsuccessful! confirmed (error code number)"	Make sure that the server has been started. Inform the developer of the error code.
"The server has no current database!"	Create a new data base in the MXChange server.
"The request object dose not exist!"	Start the MXChange server.
"Please input the Project node."	Set the project of the export destination.
"Comment data was not found."	Create a new comment data name on GX Developer.
"The old password was incorrect."	Set a correct password.
"Licencing limits exceeded."	Export within the permitted number of tags.
"The PLC type of the exporting project node differs with the PLC type of the actual project. Please create a new Project node or specify the project node having the PLC type same as the project."	Create a new project of the export destination separately, or choose the project of the same CPU type as that of GX Developer for the export destination.
"MXChange server Disconnect!"	Start the MXChange server or log in again.
"Bad 1st character of MXChange tag name."	Using correct characters, re-set the tag name.
"The connection is broken. Processing is canceled. A partial data was Exported."	Log in to the server again.
"Project is already used by user!"	Execute after logging off MXChange in the corresponding application.
"Project node is not exist in MXChange server!"	Perform operation after create the MELSEC project node.
"This PLC type is not available in MXChange."	An attempt was made to export the comment data of the CPU type of the GX Developer project not supported by MXChange. Choose the MXChange Project node of the same CPU type as that of GX Developer Project at Export.

APPENDIX

App.

Appendix 1 Restrictions on Using SX Controller

This chapter explains the restrictions on functions of GX Developer when using SX Controller.

(1) Restrictions on PLC parameter

- "Compatibility with A-PLC" on <<PLC system>> cannot be set.
- "Low speed program execution time" on <<PLC RAS>> cannot be set.

(2) Restriction on network parameter

Ethernet parameter cannot be set.

(3) Restrictions on program list monitor

- "Monitor time" fields of "Total scan time" are masked.
- "Low speed program" field of "Scan execution part, detailed scan time" is masked.

(4) Restriction on sampling trace

The setting range when "Interval" is selected for the "Trace point setup", is as follows.

CPU type	Range	Unit
SX Controller	1 to 5000ms	1ms

(5) Restriction on Ethernet diagnostics

Ethernet diagnostics cannot be executed when Q25SS is selected for CPU type.

(6) Restrictions on system monitor

- **Installed status**
The CPU type name is not displayed when SX Controller is not operated on a PC CPU. (The field is displayed blank.)
- **PLC diagnostics button**
Ethernet diagnostics cannot be executed when SX Controller is selected as a CPU type on GX Developer.

Appendix 2 Accessing to MAC

The following shows the setting when accessing to MAC by using RS-232C serial communications.

1. Select RS-232C and click the **Setup** button on the "PC side I/F Serial setting" of the "Transfer Setup" screen.

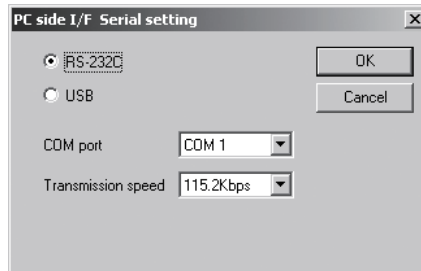

2. Set "Parity", "Data Bits", and "Stop Bits" on the "Transfer Setup: PC side I/F Serial Setting" screen.

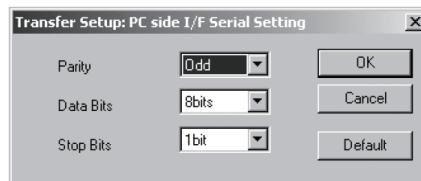

Note that, if the project with this setting is opened by GX Developer Version 8.04E or earlier, the setting is discarded.

If the project created by GX Developer Version 8.04E or earlier is opened by GX Developer Version 8.05F or later, the default setting is displayed.

POINT

- Set "via MAC/MTA transparent mode" on the "PLC side I/F Detailed setting of PLC module" screen only when MAC/MTA is used.

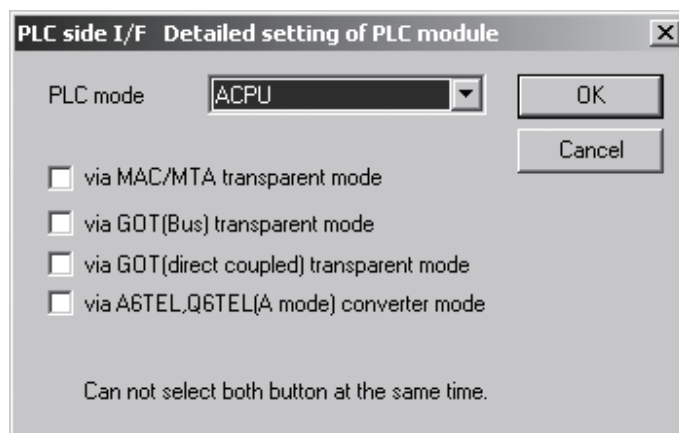

Appendix 3 Restrictions When Changing CPU Types

The following table shows the restrictions when changing CPU types between QCPU (Q mode) and Q25SS.

Item		Restrictions	
		QCPU (Q mode) → Q25SS	Q25SS → QCPU (Q mode)
Programs	Instructions	<ul style="list-style-type: none"> Incompatible instructions are converted into SM999. 	<ul style="list-style-type: none"> No restrictions (Since Q25SS-dedicated instructions, if converted, do not result in errors, perform a program check and correct the program after conversion.)
	Devices	<ul style="list-style-type: none"> Incompatible devices (SM1024/SD1024 and later) are converted into SD999. When the program is converted into a Q00J program, file registers (R, ZR) are converted into SD999. 	
Device memory		<ul style="list-style-type: none"> No restrictions 	<ul style="list-style-type: none"> No restrictions
Device comments			
PLC parameters		<ul style="list-style-type: none"> Remote password is deleted. 	<ul style="list-style-type: none"> No restrictions
Network parameters			
	MELSECNET/H MELSECNET/10	<ul style="list-style-type: none"> No restrictions 	<ul style="list-style-type: none"> No restrictions
	CC-Link	<ul style="list-style-type: none"> No restrictions 	<ul style="list-style-type: none"> No restrictions
	Ethernet	<ul style="list-style-type: none"> Ethernet setting is deleted. 	—

Microsoft Windows, Microsoft Windows NT are registered trademarks of Microsoft Corporation in the United States and other countries.

Pentium is a registered trademark of Intel Corporation in the United States and other countries.

Other company and product names herein are either trademarks or registered trademarks of their respective owners.

SPREAD

Copyright (C) 1998 Farpoint Technologies, Inc.

GX Developer Version 8

Operating Manual(Special Functions for Overseas)

MODEL	GXDEV8-O-FO-E
MODEL CODE	13JU60
SH(NA)-080760ENG-A(0801)MEE	



HEAD OFFICE : TOKYO BUILDING, 2-7-3 MARUNOUCHI, CHIYODA-KU, TOKYO 100-8310, JAPAN
NAGOYA WORKS : 1-14, YADA-MINAMI 5-CHOME, HIGASHI-KU, NAGOYA, JAPAN

When exported from Japan, this manual does not require application to the Ministry of Economy, Trade and Industry for service transaction permission.

Specifications subject to change without notice.