



PROGRAMMABLE CONTROLLERS
MELSEC-F

FX3U-64DP-M

INSTALLATION MANUAL



Manual Number	JY997D19901
Revision	D
Date	April 2015

This manual describes the part names, dimensions, installation, and specifications of the product. Before use, read this manual and manuals of relevant products fully to acquire proficiency in handling and operating the product. Make sure to learn all the product information, safety information, and precautions.

And, store this manual in a safe place so that you can take it out and read it whenever necessary. Always forward it to the end user.

Registration
The company name and the product name to be described in this manual are the registered trademarks or trademarks of each company.

Effective April 2015
Specifications are subject to change without notice.

© 2005 Mitsubishi Electric Corporation

Safety Precaution (Read these precautions before use.)

This manual classifies the safety precautions into two categories:

WARNING and **CAUTION**

WARNING	Indicates that incorrect handling may cause hazardous conditions, resulting in death or severe injury.
CAUTION	Indicates that incorrect handling may cause hazardous conditions, resulting in medium or slight personal injury or physical damage.

Depending on circumstances, procedures indicated by **CAUTION** may also be linked to serious results.
In any case, it is important to follow the directions for usage.

Associated Manuals

Manual name	Manual No.	Description
FX3U Series User's Manual - Hardware Edition	JY997D16501 MODEL CODE: 09R516	Explains FX3U Series PLC specification details for I/O, wiring, installation, and maintenance.
FX3UC Series User's Manual - Hardware Edition	JY997D28701 MODEL CODE: 09R519	Explains FX3UC Series PLC specification details for I/O, wiring, installation, and maintenance.
FX3S/FX3G/FX3GC/FX3U/FX3UC Series Programming Manual - Basic & Applied Instruction Edition	JY997D16601 MODEL CODE: 09R517	Describes PLC programming for basic/applied instructions and devices.
FX3U-64DP-M User's Manual	JY997D19201	Contents explanations for wiring, installation, specification and allocation of BFM, etc. for FX3U-64DP-M PROFIBUS-DP Master Block.
GX Configurator-DP Configuration System for Open Networks Software Manual	-	Contents explanations for operation of GX Configurator-DP Configuration System for Open Networks Software.

How to obtain manuals
For the necessary product manuals or documents, consult with the Mitsubishi Electric dealer from where you purchased your product.

Certification of UL, cUL standards

The following product has UL and cUL certification.

UL, cUL File Number:E95239

Models: MELSEC FX3U series manufactured FX3U-64DP-M

Compliance with EC directive (CE Marking)

This note does not guarantee that an entire mechanical module produced in accordance with the contents of this note will comply with the following standards. Compliance to EMC directive and LVD directive for the entire mechanical module should be checked by the user / manufacturer. For more details please contact the local Mitsubishi Electric sales site.

Requirement for Compliance with EMC directive

The following products have shown compliance through direct testing (of the identified standards below) and design analysis (through the creation of a technical construction file) to the European Directive for Electromagnetic Compatibility (2004/108/EC) when used as directed by the appropriate documentation.

Attention

- This product is designed for use in industrial applications.

Note

- Authorized Representative in the European Community:
Mitsubishi Electric Europe B.V.
Gothaer Str. 8, 40880 Ratingen, Germany

Type: Programmable Controller (Open Type Equipment)

Models: MELSEC FX3U series manufactured

from August 1st, 2005 FX3U-64DP-M

Standard	Remark
EN61131-2:2007 Programmable controllers - Equipment requirements and tests	Compliance with all relevant aspects of the standard. EMI • Radiated Emissions • Conducted Emissions EMS • Radiated electromagnetic field • Fast transient burst • Electrostatic discharge • High-energy surge • Voltage drops and interruptions • Conducted RF • Power frequency magnetic field

Caution for Compliance with EC Directive

- Caution for wiring
For noise prevention please attach at least 50 mm (1.97") of the twisted-pair cable along the grounding plate to which the ground terminal is connected.
→ For details of wiring, refer to Section 3.2

- Installation in Enclosure
→ For detail of installation in enclosure of FX3U Series PLC, refer to FX3U User's Manual - Hardware Edition.
→ For detail of installation in enclosure of FX3UC¹ Series PLC, refer to FX3UC Series User's Manual - Hardware Edition.

*1 An FX2NC-CNV-IF or FX3UC-1PS-5V is necessary to connect to the 64DP-M with the FX3UC Series PLC.
However, the 64DP-M cannot be connected to the FX3UC-32MT-LT(-2).

1. Introduction

The FX3U-64DP-M PROFIBUS-DP Master Block (hereafter called "64DP-M") is a Master (Class 1) for the PROFIBUS-DP network. The FX3U/FX3UC¹ Series PLC, when connected to the 64DP-M, can read input data from the DP-Slave, and write output data to the DP-Slave. Only one 64DP-M can be connected directly to the FX3U/FX3UC¹ series PLC's extension port, or to any other extension unit / block's right side extension port.
→ For details, refer to FX3U-64DP-M User's Manual

*1 An FX2NC-CNV-IF or FX3UC-1PS-5V is necessary to connect to the 64DP-M with the FX3UC Series PLC.
However, the 64DP-M cannot be connected to the FX3UC-32MT-LT(-2).

1.1 Incorporated Items

Product	FX3U-64DP-M PROFIBUS-DP Master Block
Included Items	Special Unit/Block No. label x1 sheet Dust proof sheet x1 sheet Manual (this manual)

1.2 External Dimensions and Part Names

Dimensions: mm (inches) MASS (Weight): Approx. 0.2kg (0.44 lbs)

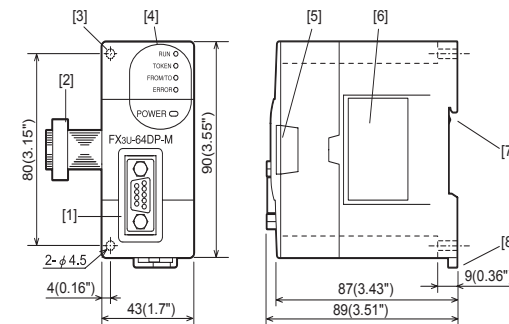

- PROFIBUS-DP port (9-pin D-SUB Connector: #4-40unc inch screw thread)
- Extension cable
- Direct mounting hole: 2 holes of $\phi 4.5$ (0.18") (mounting screw: M4 screw)
- Status LED

LED Name	Color	Description
RUN	Green	Lit: During normal operation → For other status, refer to FX3U-64DP-M User's Manual
TOKEN	Green	Lit when token is maintained.
FROM/TO	Green	Lit when accessing from PLC by FROM/TO instruction.
ERROR	Red	Unlit: During normal operation Otherwise: An error occurs. → For error details, refer to FX3U-64DP-M User's Manual
POWER	Green	Lit while 24V DC power is properly supplied from FX3U PLC.

- Extension port under the top cover
- Name plate
- DIN rail mounting groove (DIN rail: DIN46277)
- DIN rail mounting hook

1.3 Pin configuration of PROFIBUS-DP Connector

The connector is a 9-pin D-SUB (#4-40unc inch screw thread) type, with the pin configuration shown below.

Pin No.	Signal Name	Meaning
3	RXD/TXD-P	Receive/transmit-Data-P
5	DGND	Data Ground
6	VP	Voltage-Plus (5V, 90mA)
8	RXD/TXD-N	Receive/transmit-Data-N
1, 2, 4, 7, 9	NC	Pin not assigned

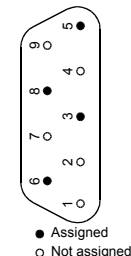

2. Installation

INSTALLATION PRECAUTIONS

WARNING

- Cut off all phases of the power source externally before starting the installation or wiring work, thus avoiding electric shock or damages to the product.

INSTALLATION PRECAUTIONS

CAUTION

- Use the product in the environment within the general specifications described in the PLC main unit manual (Hardware Edition). Never use the product in areas with dust, oily smoke, conductive dusts, corrosive gas (salt air, Cl₂, H₂S, SO₂, or NO₂), flammable gas, vibrations or impacts, or expose it to high temperature, condensation, or wind and rain. If the product is used in such a place described above, electrical shock, fire, malfunction, damage, or deterioration may be caused.
- Install the product securely using the DIN rail or screws.
- Install the product on a flat surface. If the mounting surface is rough, undue force will be applied to the PC board, thereby causing nonconformity.
- When drilling screw holes or wiring, cutting chips or wire chips should not enter ventilation slits. This may cause fire, failures, or malfunctions.
- Be sure to remove the dust proof sheet from the PLC's ventilation port when the installation work is completed. Failure to do so could cause fires, equipment failures, and malfunctions.
- Fit the extension cables and communication cables securely to the designated connectors. Contact failures may cause malfunctions.
- Do not touch the conductive parts of the product directly, in order to avoid failure or malfunction.

2.1 Arrangements

The 64DP-M connects on the right side of an FX3U/FX3UC¹ series main unit or extension units/blocks (including special function units/blocks). However, PLC can connect extension equipment to both the right and left-hand sides. When there is the plan for adding additional extension equipment in the future, please keep the appropriate space available on both sides of the main unit. For further information of installation arrangements, refer to the following manual.

→ FX3U Series User's Manual - Hardware Edition
→ FX3UC Series User's Manual - Hardware Edition

*1 An FX2NC-CNV-IF or FX3UC-1PS-5V is necessary to connect to the 64DP-M with the FX3UC Series PLC.
However, the 64DP-M cannot be connected to the FX3UC-32MT-LT(-2).

2.2 Mounting

The 64DP-M can be mounted on a DIN rail (DIN46227) or mounted directly using screws. For the details of installation, refer to the following manual.

→ FX3U-64DP-M User's Manual
→ FX3U Series User's Manual - Hardware Edition
→ FX3UC Series User's Manual - Hardware Edition

2.2.1 Direct Mounting

The 64DP-M can be mounted with M4 screws by using the direct mounting holes. An interval space between each unit of 1 to 2 mm (0.04" to 0.08") is necessary.
→ For the mounting hole pitch information, refer to Section 1.2

2.2.2 DIN Rail Mounting

The 64DP-M can be mounted on a DIN rail (DIN46227, 35mm width).

- Fit the upper edge of the DIN rail mounting groove (right fig. A) onto the DIN rail.
- Push the product onto the DIN rail.

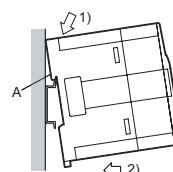

- Connect extension cable to the main unit, I/O extension unit/block, or special function unit/block of the left side.

→ FX3U Series User's Manual - Hardware Edition
→ FX3UC Series User's Manual - Hardware Edition

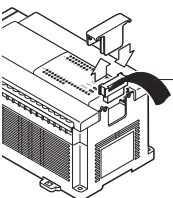

3. Wiring

DESIGN PRECAUTIONS **CAUTION**

- Make sure to observe the precautions below in order to prevent any damage to a machine or any accident which might be caused by abnormal data written in the PLC due to the influence of noise:
 - Do not lay wires close or bundle with the main circuit, high-voltage power line, or load line.
Otherwise effects of noise or surge induction are likely to take place. Keep a safe distance of more than 100 mm (3.94") from the above when wiring.
 - Ground the shield wire or shield of a shielded cable at one point on the PLC. However, do not ground at the same point as high voltage lines.
- Install in a manner which prevents excessive force from being applied to the connectors for peripheral device connections.
Failure to do so may result in wire breakage or failure of the PLC.

WIRING PRECAUTIONS **WARNING**

- Cut off all phases of power source externally, before installation or wiring work in order to avoid electric shock or damage of product.

WIRING PRECAUTIONS **CAUTION**

- Never let cutting chips and wire chips enter the ventilation slits of this product or PLC when performing wiring.
Otherwise, fire, failure, or malfunction may occur.
- When drilling screw holes or wiring, cutting chips or wire chips should not enter ventilation slits. This may cause fire, failures, or malfunctions.

3.1 Applicable Cable and Connector

The following table shows the applicable cable and connector for PROFIBUS-DP network.

Item	Description
PROFIBUS-DP network cable	Shielded twisted-pair PROFIBUS cable complying with EN50170
Connector	Applicable only to PROFIBUS connector (9-pin D-SUB Connector: #4-40unc inch screw thread) → For PROFIBUS connectors see the PROFIBUS connector manual

3.2 Wiring

To connect the 64DP-M to a PROFIBUS-DP network, use only the PROFIBUS connector and shielded twisted-pair PROFIBUS cable complying with EN50170.

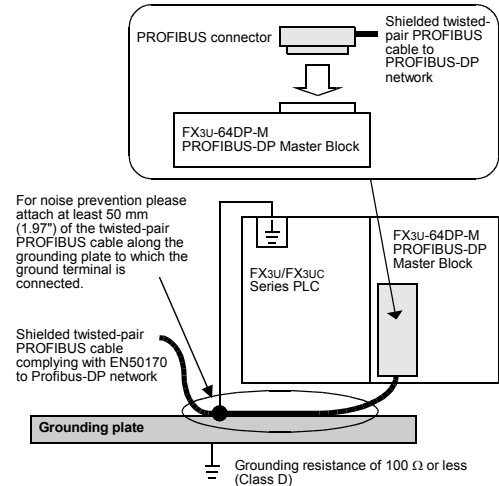

3.3 Grounding

Grounding should be performed as stated below.

- The grounding resistance should be 100Ω or less.
- Independent grounding should be performed for best results.
When independent grounding is not performed, perform "shared grounding" of the following figure.
→ For details, refer to the FX3U Series User's Manual - Hardware Edition.
→ For details, refer to the FX3UC Series User's Manual - Hardware Edition.

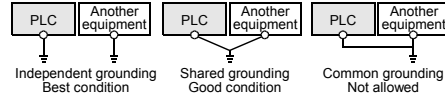

- The grounding wire size should be as follows.

PLC Type	Grounding Wire Size
FX3U Series PLC	AWG 14 (2 mm ²) or larger
FX3UC Series PLC	AWG 22-20 (0.3 to 0.5 mm ²)

- The grounding point should be close to the PLC, and all grounding wire should be as short as possible.

3.4 Bus Terminator

The units at each end of the PROFIBUS-DP network must have a bus terminator. This will either be in the DP-Master or DP-Slave unit or in the PROFIBUS connector. However, the 64DP-M does not have a terminating resistance built-in.

4. Specifications

DESIGN PRECAUTIONS **WARNING**

- Provide a safety circuit on the outside of the PLC so that the whole system operates to ensure the safety even when external power supply trouble or PLC failure occurs.
Otherwise, malfunctions or output failures may result in an accident.
 - An emergency stop circuit, a protection circuit, an interlock circuit for opposite movements, such as normal and reverse rotations, and an interlock circuit for preventing damage to the machine at the upper and lower positioning limits should be configured on the outside of the PLC.
 - When the PLC CPU detects an error, such as a watch dog timer error, during self-diagnosis, all outputs are turned off. When an error that cannot be detected by the PLC CPU occurs in an input/output control block, output control may be disabled.
Design external circuits and mechanisms to ensure safe operations of the machine in such a case.
 - When some sort of error occurs in a relay, triac or transistor of the output unit/block, output may be kept on or off.
For output signals that may lead to serious accidents, design external circuits and mechanisms to ensure safe operations of the machine.

DESIGN PRECAUTIONS **CAUTION**

- Make sure to observe the precautions below in order to prevent any damage to a machine or any wires accident which might be caused by abnormal data written in the PLC due to the influence of noise:
 - Do not lay close or bundle with the main circuit, high-voltage power line, or load line.
Otherwise effects of noise or surge induction are likely to take place. Keep a safe distance of more than 100 mm (3.94") from the above when wiring.
 - Ground the shield wire or shield of a shielded cable at one point on the PLC. However, do not ground at the same point as high voltage lines.
- Install in a manner which prevents excessive force from being applied to the connectors for peripheral device connections.
Failure to do so may result in wire breakage or failure of the PLC.

STARTUP AND MAINTENANCE PRECAUTIONS **WARNING**

- Do not touch any terminal while the PLC's power is on. Doing so may cause electrical shock or malfunctions.
- Before cleaning or retightening terminals, externally cut off all phases of the power supply.
Failure to do so may expose you to shock hazard.
- Before modifying the program under operation or performing operation for forcible output, running or stopping, carefully read the manual, and sufficiently ensure the safety.
An operation error may damage the machine or cause accidents.

STARTUP AND MAINTENANCE PRECAUTIONS **CAUTION**

- Do not disassemble or modify the unit.
Doing so may cause failure, malfunction or fire.
* For repair, contact your local Mitsubishi Electric distributor.
- Do not drop the product or do not exert strong impact, as doing so may cause damage.
- Before connecting or disconnecting any extension cable, turn off power.
Failure to do so may cause unit failure or malfunctions.

DISPOSAL PRECAUTIONS **CAUTION**

- Please contact a company certified in the disposal of electronic waste for environmentally safe recycling and disposal of the product.

TRANSPORT AND STORAGE PRECAUTIONS **CAUTION**

- During transportation, avoid any impact as the product is a precision instrument. Check the operation of the product after transportation.

4.1 Applicable PLC

Model name	Applicability
FX3U Series PLC	Ver. 2.21 or later
FX3UC Series PLC ^{*1}	Ver. 2.21 or later

*1 An FX2NC-CNV-IF or FX3UC-1PS-5V is necessary to connect to the 64DP-M with the FX3UC Series PLC.
However, the 64DP-M cannot be connected to the FX3UC-32MT-LT(-2).

4.2 General Specifications

For the general specification, refer to the manual of the PLC main unit. The items other than the following are equivalent to those of the PLC main unit. However, please don't perform any dielectric withstand voltage tests and insulation resistance tests to this product.
→ Refer to FX3U Series User's Manual - Hardware Edition
→ Refer to FX3UC Series User's Manual - Hardware Edition

Item	Specifications	
Withstand voltage	500 V AC for 1 min	Between communication connector frame and ground terminal of PLC main unit
Insulation resistance	5 MΩ or more by 500 V DC Megger	

4.3 Power Supply Specifications

24V DC, 155 mA is supplied from the internal power supply (service power supply) in main unit.

4.4 Performance Specifications

Item	Specifications
Transmission Type	Bus network
Unit Type	PROFIBUS-DP master Class 1
Transmission Data (Maximum Exchanged Data Length)	* Normal service mode: 32 bytes / slave * Extended service mode (default): 244 bytes/slave
Maximum Number of FX3U-64DP-M at one PLC	1 unit
Maximum Number of FX3U-64DP-M at one PROFIBUS-DP Network	3 units In case of multi master configuration, all master stations must be FX3U-64DP-M.

Item	Specifications		
Maximum Number of Repeaters / Communication Path	3 units		
Maximum Number of Stations / Segment	32 stations		
Maximum Number of Slaves / Master	64 slaves		
No. of Connectable Nodes	31, 61 (1), 91 (2), 121 (3)		
Supported Transmission speed (bps) and Bus Length	9.6k, 19.2k, 93.75k	1,200 m (3,937') / segment	See Section 4.5
	187.5k	1,000 m (3,281') / segment	
	500k	400 m (1,312') / segment	
	1.5 M	200 m (656') / segment	
	3M, 6M, 12M	100 m (328') / segment	
PNO ID	"F364" hex		
Connector	PROFIBUS-DP Network	Port for PROFIBUS-DP network (9 pin D-SUB Connector)	
Global Control	Synchronization, unsynchronization, freeze and unfreeze modes are supported.		
Terminal Resistor	Not built in.		

4.5 Maximum Bus Length and Baud Rate

Length that the bus can be expanded by using repeaters.
Maximum Bus Length = (No. of repeaters + 1) * (Bus Length / segment)

Baud Rate (bps)	Maximum Bus Length			
	No repeater	1 repeater	2 repeaters	3 repeaters
9.6k, 19.2k, 93.75k	1,200 m (3,937')	2,400 m (7,874')	3,600 m (11,811')	4,800 m (15,748')
187.5k	1,000 m (3,281')	2,000 m (6,562')	3,000 (9,843')	4,000 m (13,123')
500k	400 m (1,312')	800 m (2,625')	1,200 m (3,937')	1,600 m (5,249')
1.5 M	200 m (656')	400 m (1,312')	600 m (1,969')	800 m (2,625')
3M, 6M, 12M	100 m (328')	200 m (656')	300 m (984')	400 m (1,312')

This manual confers no industrial property rights or any rights of any other kind, nor does it confer any patent licenses. Mitsubishi Electric Corporation cannot be held responsible for any problems involving industrial property rights which may occur as a result of using the contents noted in this manual.

Warranty

Mitsubishi will not be held liable for damage caused by factors found not to be the cause of Mitsubishi; opportunity loss or lost profits caused by faults in the Mitsubishi products; damage, secondary damage, accident compensation caused by special factors unpredictable by Mitsubishi; damages to products other than Mitsubishi products; and to other duties.

For safe use

- This product has been manufactured as a general-purpose part for general industries, and has not been designed or manufactured to be incorporated in a device or system used in purposes related to human life.
- Before using the product for special purposes such as nuclear power, electric power, aerospace, medicine or passenger movement vehicles, consult with Mitsubishi Electric.
- This product has been manufactured under strict quality control. However when installing the product where major accidents or losses could occur if the product fails, install appropriate backup or failsafe functions in the system.

MITSUBISHI ELECTRIC CORPORATION

HEAD OFFICE : TOKYO BUILDING, 2-7-3 MARUNOUCHI, CHIYODA-KU, TOKYO 100-8310, JAPAN