

# MITSUBISHI

**MODEL GT15V-75V4R1 Video/RGB Input Unit**

**MODEL GT15V-75V4 Video Input Unit**

**MODEL GT15V-75R1 RGB Input Unit**

## User's Manual

Thank you for purchasing the GOT1000 Series.

Prior to use, please read both this manual and detailed manual thoroughly to fully understand the product.

MODEL	GT15V-75V4R1-U
MODEL CODE	1D7M54
IB(NA)-0800348-E(1106)MEE	

GRAPHIC OPERATION TERMINAL

# GOT1000

## ●SAFETY PRECAUTIONS●

(Always read these precautions before using this equipment.)

Before using this product, please read this manual and the relevant manuals introduced in this manual carefully and pay full attention to safety to handle the product correctly.

The precautions given in this manual are concerned with this product.

In this manual, the safety precautions are ranked as "DANGER" and "CAUTION".



**DANGER**

Indicates that incorrect handling may cause hazardous conditions, resulting in death or severe injury.



**CAUTION**

Indicates that incorrect handling may cause hazardous conditions, resulting in medium or slight personal injury or physical damage.

Note that the  caution level may lead to a serious accident according to the circumstances. Always follow the instructions of both levels because they are important to personal safety.

Please save this manual to make it accessible when required and always forward it to the end user.

## [DESIGN PRECAUTIONS]

### CAUTION

- Do not bunch the control wires or communication cables with the main circuit or power wires, or lay them close to each other.  
As a guide, separate the lines by a distance of at least 100mm (3.94 inches) otherwise malfunctions may occur due to noise.

## [MOUNTING PRECAUTIONS]

### DANGER

- Be sure to shut off all phases of the external power supply used by the system before mounting or removing this unit onto/from the GOT.  
Not doing so can cause the unit to fail or malfunction.

### CAUTION

- Use this unit in the environment that satisfies the general specifications described in the User's Manual for the GOT used.  
Not doing so can cause an electric shock, fire, malfunction or product damage or deterioration.
- Tighten the mounting screws within the specified torque range.  
Undertightening can cause the GOT to drop, short circuit or malfunction.  
Overtightening can cause a drop, short circuit or malfunction due to the damage of the screws or the GOT.
- Do not touch the conductive and electronic parts of the unit directly.  
Doing so can cause a unit malfunction or failure.

## [WIRING PRECAUTIONS]

### **DANGER**

- Be sure to shut off all phases of the external power supply used by the system before wiring.  
Failure to do so may result in an electric shock, product damage or malfunctions.

### **CAUTION**

- Exercise care to avoid foreign matter such as chips and wire offcuts entering the GOT. Not doing so can cause a fire, failure or malfunction.
- Make sure to securely connect the cable to the connector of unit.  
Incorrect connection may cause malfunctions.
- Do not hold the cable by hand and pull it out from the unit.  
When removing the cable from the unit, make sure to hold the connector by hand and pull it.  
Failure to do so may cause malfunctions or damage to the unit or cable.
- Solder the coaxial cable connector correctly.  
Incomplete soldering may cause a malfunction.

## [STARTUP/MAINTENANCE PRECAUTIONS]

### DANGER

- When power is on, do not touch the terminals.  
Doing so can cause an electric shock or malfunction.
- Before starting cleaning, always shut off GOT power externally in all phases.  
Not doing so can cause a unit failure or malfunction.  
Undertightening can cause a short circuit or malfunction.  
Overtightening can cause a short circuit or malfunction due to the damage of the screws or unit.

### CAUTION

- Do not disassemble or modify the unit.  
Doing so can cause a failure, malfunction, injury or fire.
- Do not drop the module or subject it to strong shock.  
A module damage may result.
- Before touching the unit, always touch grounded metal, etc. to discharge static electricity from human body, etc.  
Not doing so can cause the unit to fail or malfunction.

## [DISPOSAL PRECAUTIONS]

### CAUTION

- When disposing of the product, handle it as industrial waste.

## [TRANSPORTATION PRECAUTIONS]

### CAUTION

- Make sure to transport the GOT main unit and/or relevant unit(s) in the manner they will not be exposed to the impact exceeding the impact resistance described in the general specifications of the User's Manual for the GOT used, as they are precision devices.  
Failure to do so may cause the unit to fail.  
Check if the unit operates correctly after transportation.

## REVISIONS

\* The manual number is noted at the lower right of the top cover.

Print Date	*Manual Number	Revision
Mar., 2006	IB(NA)-0800348-A	First edition
Feb., 2007	IB(NA)-0800348-B	<p>Partial addition</p> <p>Chapter1, Section 2.4.1</p> <p>Addition</p> <p>Compliance with the EMC and Low Voltage Directives</p>
Jul., 2007	IB(NA)-0800348-C	<p>Partial corrections</p> <p>Compliance with the EMC and Low Voltage Directives, Chapter 2, 3, 4</p>
Jun., 2009	IB(NA)-0800348-D	<p>Partial corrections</p> <p>Compliance with the EMC and Low Voltage Directives</p>
Jun., 2011	IB(NA)-0800348-E	<p>Addition</p> <p>Compliance with the Radio Waves Act (South Korea)</p>

This manual confers no industrial property rights or any rights of any other kind, nor does it confer any patent licenses. Mitsubishi Electric Corporation cannot be held responsible for any problems involving industrial property rights which may occur as a result of using the contents noted in this manual.

© 2006 MITSUBISHI ELECTRIC CORPORATION

---

---

# CONTENTS

---

---

1. OVERVIEW .....	1
2. SPECIFICATIONS .....	4
2.1 Video input unit specifications .....	4
2.2 RGB input unit specifications .....	5
2.3 Video/RGB input unit specifications .....	6
2.4 Cable specifications .....	7
2.4.1 Specifications of the cables (coaxial cables) used when displaying video images .....	7
2.4.2 Specifications of the cables (9-core combined cables) used when displaying RGB screens .....	10
3. PART NAMES AND EXTERNAL DIMENSIONS .....	11
3.1 Part names and external dimensions of the video input unit .....	11
3.2 Part names and external dimensions of the RGB input unit .....	12
3.3 Part names and external dimensions of the video/RGB input unit .....	13
3.4 External dimensions of the extension interface relay board .....	14
4. INSTALLATION PROCEDURE .....	15

## Manuals

The following shows manuals relevant to this product.

### Detailed Manual

Manual name	Manual number (Model code)
GT15 User's Manual (Sold separately)	SH-080528ENG (1D7M23)
GOT1000 Series Connection Manual (Microcomputer, MODBUS Products, Peripherals) for GT Works3 (Sold separately)	SH-080871ENG (1D7MC5)

### Relevant Manuals

For relevant manuals, refer to the PDF manuals stored in the CD-ROM for the drawing software used.

## Packing List

The following items are included.

Model	Product	Quantity
GT15V-75V4	Video input unit	1
	Mounting screw set (2 screws,2 stickers)	2
	Extend interface relay board	1
GT15V-75R1	RGB input unit	1
	Mounting screw set (2 screws,2 stickers)	2
	Extend interface relay board	1
GT15V-75V4R1	Video/RGB input unit	1
	Mounting screw set (2 screws,2 stickers)	2
	Extend interface relay board	1

## Compliance with the EMC and Low Voltage Directives

To configure a system meeting the requirements of the EMC and Low Voltage Directives when incorporating the Mitsubishi GOT (EMC and Low Voltage Directives compliant) into other machinery or equipment, refer to "EMC AND LOW VOLTAGE DIRECTIVES" of the General Description included with the GOT used.

The CE mark, indicating compliance with the EMC and Low Voltage Directives, is printed on the rating plate of the GOT.

## Compliance with the Radio Waves Act (South Korea)

This product complies with the Radio Waves Act (South Korea).

Note the following when using the product in South Korea.

이 기기는 업무용 (A급) 전자파적합기기로서 판매자 또는 사용자는 이 점을 주의하시기  
바라며, 가정외의 지역에서 사용하는 것을 목적으로 합니다.

(The product is for business use (Class A) and meets the electromagnetic compatibility requirements. The seller and the user must note the above point, and use the product in a place except for home.)



---

---

# 1. OVERVIEW

---

---

This User's Manual is related to the following units.

- MODEL GT15V-75V4 Video Input Unit (hereinafter referred to as the Video Input Unit)
- MODEL GT15V-75R1 RGB Input Unit (hereinafter referred to as the RGB Input Unit)
- MODEL GT15V-75V4R1 Video/RGB Input Unit (hereinafter referred to as the Video/RGB Input Module).

When mounting the above units with the GT1585V-STBA, GT1575V-STBA (hereinafter referred to as GOT), the images taken by video cameras or screens on personal computers can be displayed on the GOT.

The video input unit can display the images taken by up to 4 video cameras on the GOT.

GOT can be used as a vision sensor monitor.

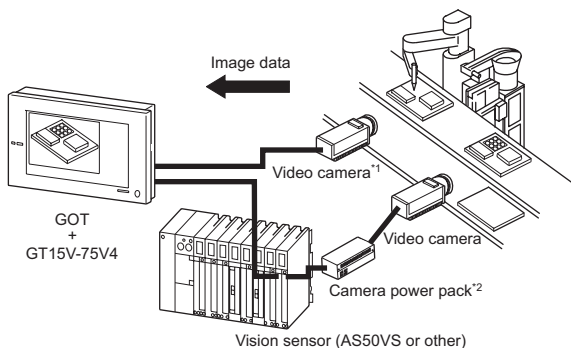

\*1: Power on the video camera simultaneously with the GOT.

\*2: Power supply for the camera may be necessary depending on the vision sensor to be used.

The RGB input unit can display a personal computer display on the GOT. Video input is also available using an RGB output type vision sensor.

When connecting to a personal computer



\*1: When connecting with a personal computer, ground wire of the computer should be grounded.

When connecting to a video camera using an RGB output type vision sensor.

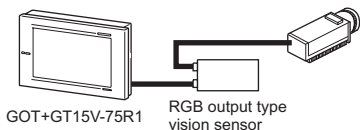

For the video/RGB input unit, functions of both video input unit (GT15V-75V4) and RGB input unit (GT15V-75R1) are available.

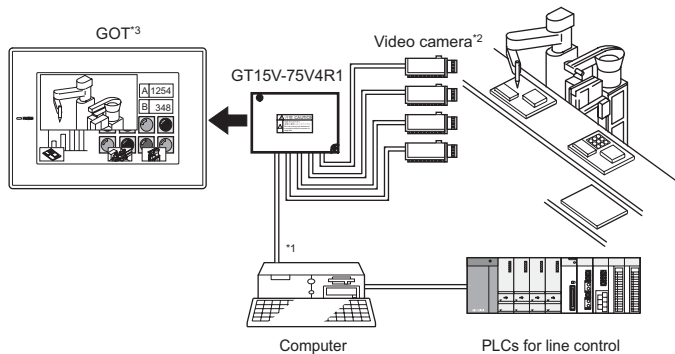

- \*1: When connecting the unit to a personal computer, ground wire of the computer should be grounded.
- \*2: Power on the video camera simultaneously with the GOT.
- \*3: Video images and personal computer screens cannot be displayed on the GOT at the same time.

To use the Video input unit, RGB input unit and Video/RGB input unit, make the Communication Settings.

For setting details, refer to GOT1000 Series Connection Manual.

For details of system configuration, refer to GOT1000 Series Connection Manual.

For video input and RGB input functions, refer to the GT Designer2 Version□ Screen Design Manual.

---

---

## 2. SPECIFICATIONS

---

---

### 2.1 Video input unit specifications

Item		Specifications	
Video input section	Video input system	Color	NTSC format, PAL format (interlaced format)
		Monochrome	EIA format, CCIR format (interlaced format)
	Number of video input channels	4 channel	
	Input signal	IVp-p, 75Ω, composite signal	
	Display size [dot's]	640x480 (possible to reduce to 320x240, 160x120) 720x480 (possible to reduce to 360x240, 180x120) *1	
	Video external connection method	Coaxial cable	
	Applicable wire size	75Ω coaxial shield cable	
Maximum cable length	Refer to the specifications of the personal computer, vision sensor and video camera to be used *2		
Internal current consumption (3.3VDC)	0.7A		
Weight	0.2kg (0.44lb)		

\*1: Compatible with PAL and CCIR formats only.

\*2: The length of a cable differs depending on the specifications of the vision sensor and video camera to be used.

Be sure to use the cable with specified length for the vision sensor and video camera to be used.

## 2.2 RGB input unit specifications

Item		Specifications
RGB input section	RGB input method (dot's)	Analog RGB(SVGA; 800x600, VGA; 640x480)
	Number of video input channels	1 channel
	Input image signal	1Vp-p, 75Ω
	Synchronizing signal	TTL, 1kΩ
	Display size [dot's]	800× 600 (refresh rate 60, 72, 75 [Hz]) 640× 480 (refresh rate 60, 72, 75, 85 [Hz])
	RGB external connection method	D-Sub15 pin
	Applicable wire size	9-core combined cable (recommended)
Maximum cable length		Refer to the specifications of the personal computer, vision sensor and video camera to be used *1
Internal current consumption (3.3VDC)		0.91A
Weight		0.17kg (0.37lb)

\*1: The length of a cable differs depending on the specifications of the personal computer and vision sensor to be used.  
Be sure to use the cable with specified length for the personal computer and vision sensor to be used.

## 2.3 Video/RGB input unit specifications

Item		Specifications	
Video input section <sup>*3</sup>	Video input system	Color	NTSC format, PAL format (interlaced format)
		Monochrome	EIA format, CCIR format (interlaced format)
	Number of video input channels		4 channel
	Input signal		1Vp-p, 75Ω, composite signal
	Display size [dot's]		640x480 (possible to reduce to 320x240, 160x120) 720x480 (possible to reduce to 360x240, 180x120) *1
	Video external connection method		Coaxial cable
	Applicable wire size		75Ω coaxial shield cable
RGB input section <sup>*3</sup>	RGB input method (dot's)		Analog RGB(SVGA; 800x600, VGA; 640x480)
	Number of video input channels		1 channel
	Input image signal		1Vp-p, 75Ω
	Synchronizing signal		TTL, 1kΩ
	Display size [dot's]		800×600 (refresh rate 60, 72, 75 [Hz]) 640×480 (refresh rate 60, 72, 75, 85 [Hz])
	RGB external connection method		D-Sub15 pin
	Applicable wire size		9-core combined cable (recommended)
Maximum cable length		Refer to the specifications of the personal computer, vision sensor and video camera to be used <sup>*2</sup>	
Internal current consumption (3.3VDC)		0.95A	
Weight		0.21kg (0.46lb)	

\*1: Compatible with PAL and CCIR formats only.

\*2: The length of a cable differs depending on the specifications of the personal computer, vision sensor and video camera to be used.  
Be sure to use the cable with specified length for the personal computer, vision sensor and video camera to be used.

\*3: Both video images and RGB screens cannot be displayed on the GOT at the same time.

## 2.4 Cable specifications

The following shows the cable specifications, connection diagram, and connector used for the video input unit, RGB input unit, and video/RGB input unit.

### 2.4.1 Specifications of the cables (coaxial cables) used when displaying video images

(1) Coaxial cable

Use high frequency coaxial cable "3C-2V" or "5C-2V" (conforms to JIS C 3501).

The following shows the coaxial cable specifications.

Item	3C-2V	5C-2V
Construction		
Cable diameter	5.4mm (0.21in.)	7.4mm (0.29in.)
Allowable bending radius	22mm (0.87in.) or more	30mm (41.18in.) or more
Internal conductive material diameter	0.5mm (0.02in.) (Annealed copper wire)	0.8mm (0.03in.) (Annealed copper wire)
Insulation material diameter	3.1mm (0.12in.) (Polyethylene)	4.9mm (0.19in.) (Polyethylene)
External conductive material diameter	3.8mm (0.15in.) (Single annealed copper wire mesh)	5.6mm (0.22in.) (Single annealed copper wire mesh)
Applicable connector plug	Connector plug for 3C-2V (BNC-P-3-N1-CAU is recommended.)	Connector plug for 5C-2V (BNC-P-5-N1-CAU is recommended.)

(2) Connector

- GOT connector

Use BNC connector for GOT side connector.

The following shows the connection method for BNC connector and coaxial cable.

(a) Construction of BNC connector and coaxial cable.

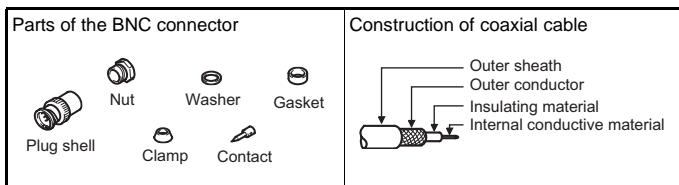

(b) Connecting the BNC connector with the coaxial cable.

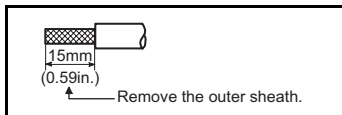

- 1) Remove the outer sheath of the coaxial cable in the specified dimension as shown left.

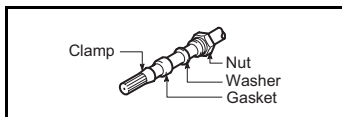

- 2) Slip a nut, a washer, a gasket, and a clamp through the coaxial cable as shown left, and loosen the outer conductor.

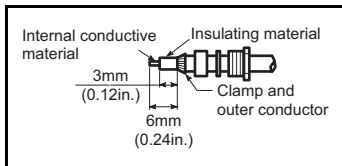

- 3) Cut off the insulating material and internal conductive material in the specified dimensions as shown left. Cut off the outer conductor in the same dimension as the taper part of the clamp, and extend it over the clamp.

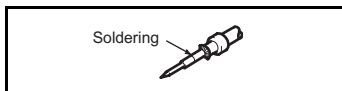

- 4) Solder the contact to the tip of the internal conductive material.

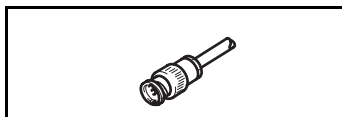

- 5) Insert the contact assembly of 4) into the plug shell, and engage the plug shell with the nut.



- \*1: Soldered part must not have excess solder mound.
- \*2: The tail end of the contact must come into close contact with the cut end of the insulating material. The contact must not be cutting in the insulating material.
- \*3: Apply solder quickly so that the insulating material will not be deformed by heat.
  - Connector at the video camera and vision sensor  
Use a connector applicable to the video camera or vision sensor to be used.

(3) Precautions for cable preparation

The maximum cable length differs depending on the specifications of the video camera and vision sensor to be used.

For details, refer to manuals for video camera and vision sensor.

When a cable length gets longer, video signals are attenuated, and video images deteriorate.

When using a cable exceeding the length described in the following table, it is recommended to correct video images using a video signal amplifier.

Cable type	Cable length [m] (feet)
3C-2V	100 (328.1)
5C-2V	200 (656.2)

(4) Precautions for laying cable

Consider wiring using double-shielded coaxial cable in places that are subject to large amounts of noise.

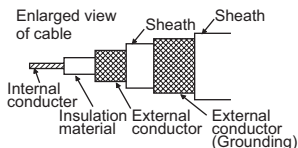
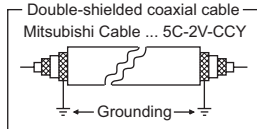

The 5C-2V connector plug is applicable to double-shielded coaxial cable.

Connect the 5C-2V connector plug to the coaxial cable inside a double-shielded coaxial cable. Ground the shielded part outside a double-shielded coaxial cable as shown in the above figure.

## 2.4.2 Specifications of the cables (9-core combined cables) used when displaying RGB screens

### (1) Cable specifications

Item	Specifications
Applicable cable	Equivalent to SP23-23352A UL20276-SB
Applicable wire size	9-core combined cable (recommended)

### (2) Connection diagram

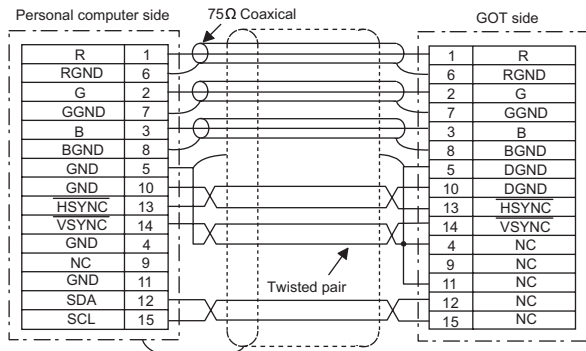

### (3) Connector

- GOT side connector

The following model is used for the GOT connector.

Use a connector that matches the following connector.

15-pin D-sub (male) inch screw type

Manufactured by DDK

17HE-R13150-73MC2

- Connector at the personal computer and vision sensor

Use the connector applicable to the personal computer and vision sensor.

### (4) Precaution for cable creating

The length of a cable differs depending on the personal computer and vision sensor to be used.

Make the cable within the range of personal computer and vision sensor specifications.

### 3. PART NAMES AND EXTERNAL DIMENSIONS

#### 3.1 Part names and external dimensions of the video input unit

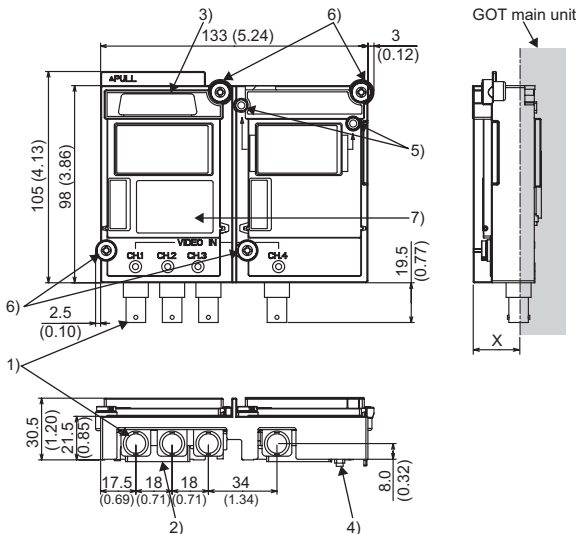

Dimensions of X when the video input unit is mounted to the GOT.

12.1"	18 (0.71)
10.4"	21 (0.83)

Unit: mm (inch)

No.	Name	Description
1)	Connector for video input	Connector for connecting a coaxial cable
2)	Interface connector	Connector mounted to the GOT
3)	Extension connector	Connector to which a back extension unit is installed
4)	Connector for video/RGB connection	Connector connecting with the video/RGB interface of GOT
5)	Board fixing screw	Screw for fixing the extend interface relay board
6)	Mounting screw	Mounting screws for fixing the unit to the GOT
7)	Rating plate	-

### 3.2 Part names and external dimensions of the RGB input unit

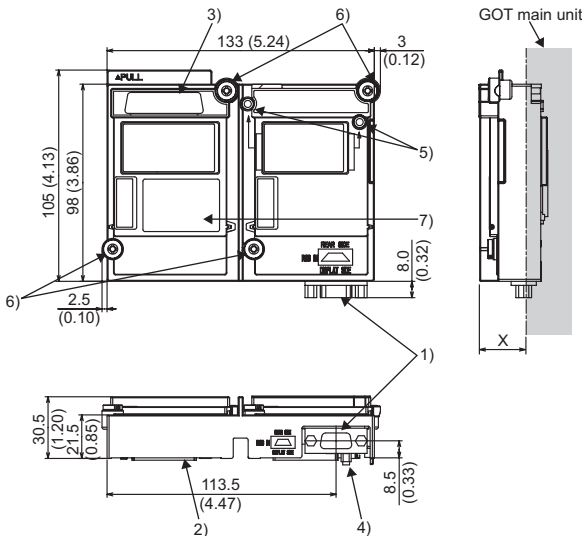

Dimensions of X when the RGB input unit is mounted to the GOT.

12.1"	18 (0.71)
10.4"	21 (0.83)

Unit: mm (inch)

No.	Name	Description
1)	Connector for RGB input	Connector for connecting 9-core combined cables
2)	Interface connector	Connector mounted to the GOT
3)	Extension connector	Connector to which a back extension unit is installed
4)	Connector for video/RGB connection	Connector connecting with the video/RGB interface of GOT
5)	Board fixing screw	Screw for fixing the extend interface relay board
6)	Mounting screw	Mounting screws for fixing the unit to the GOT
7)	Rating plate	-

### 3.3 Part names and external dimensions of the video/RGB input unit

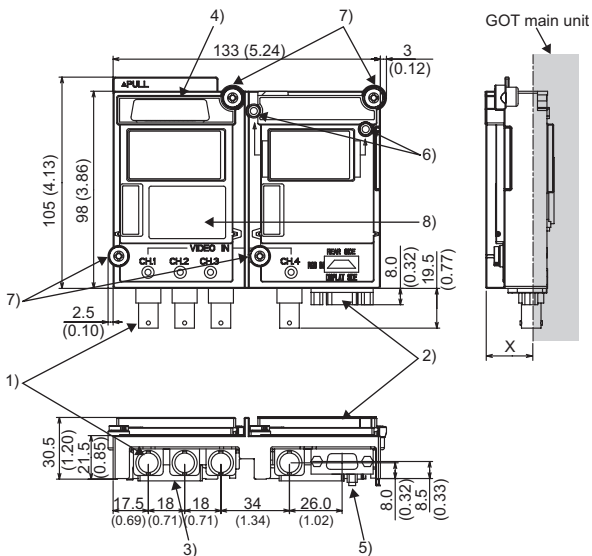

Dimensions of X when the video/RGB input unit is mounted to the GOT.

12.1"	18 (0.71)
10.4"	21 (0.83)

Unit: mm (inch)

No.	Name	Description
1)	Connector for video input	Connector for connecting a coaxial cable
2)	Connector for RGB input	Connector for connecting 9-core combined cables
3)	Interface connector	Connector mounted to the GOT
4)	Extension connector	Connector to which a back extension unit is installed
5)	Connector for video/RGB connection	Connector connecting with the video/RGB interface of GOT
6)	Board fixing screw	Screw for fixing the extend interface relay board
7)	Mounting screw	Mounting screws for fixing the unit to the GOT
8)	Rating plate	-

### 3.4 External dimensions of the extension interface relay board

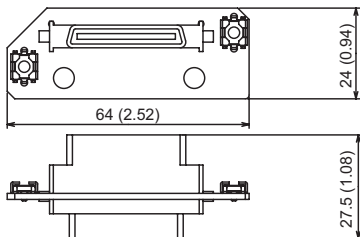

Unit: mm (inch)

---

## 4. INSTALLATION PROCEDURE

---

The installation procedure for the video/RGB input unit is explained using the GT1575.

(1) Power off the GOT.

(1) Remove two extension unit covers of the GOT.

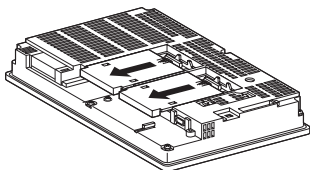

(2) Attach the extend interface relay board to the extend I/F-2 side on the GOT.

After the installation, detach the connector cover from the extend interface relay board.

(3) Fit the video/RGB input unit in the GOT case.

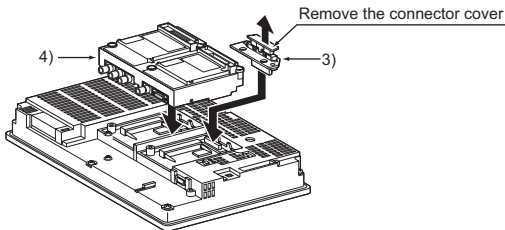

(4) Fasten the video/RGB input unit by tightening its mounting screws (4 places) with tightening torque 0.36 to 0.48 N•m.

- (5) Fasten the bus connection unit by tightening the board fixing screws (2 places) with the tightening torque of 0.36 to 0.48 N•m.

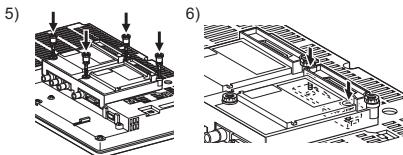

- (6) When installing an extension unit on the unit that has been installed, remove the connector cover and the sticker. When not installing an extension unit on the unit that has been installed, in order to avoid receiving electrostatic, stick accessory stickers to cover the top of mounting screws (4 places). Keep the connector cover fixed. Keep the sticker stuck as it is.

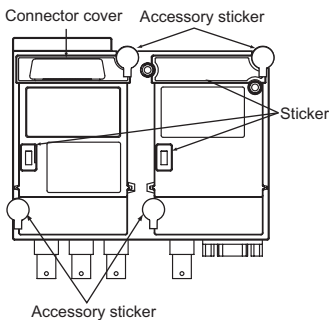

Point
Remove the screws that fixes the extend interface relay board before removing the unit.(Above 6))





## Warranty

Mitsubishi will not be held liable for damage caused by factors found not to be the cause of Mitsubishi; machine damage or lost profits caused by faults in the Mitsubishi products; damage, secondary damage, accident compensation caused by special factors unpredictable by Mitsubishi; damages to products other than Mitsubishi products; and to other duties.

### For safe use

- This product has been manufactured as a general-purpose part for general industries, and has not been designed or manufactured to be incorporated in a device or system used in purposes related to human life.
- Before using the product for special purposes such as nuclear power, electric power, aerospace, medicine or passenger movement vehicles, consult with Mitsubishi.
- This product has been manufactured under strict quality control. However, when installing the product where major accidents or losses could occur if the product fails, install appropriate backup or failsafe functions in the system.

Country/Region	Sales office/Tel	Country/Region	Sales office/Tel
U.S.A	Mitsubishi Electric Automation Inc. 500 Corporate Woods Parkway Vernon Hills, IL 60061, U.S.A. Tel : +1-847-478-2100	Hong Kong	Mitsubishi Electric Automation (Hong Kong) Ltd. 10th Floor, Manulife Tower, 169 Electric Road, North Point, Hong Kong Tel : +852-2887-8870
Brazil	MELCO-TEC Rep. Com.e Assessoria Tecnica Ltda. Rua Correia Dias, 184, Edificio Paraíso Trade Center-8 andar Paraíso, Sao Paulo, SP Brazil Tel : +55-11-5908-8331	China	Mitsubishi Electric Automation (China) Ltd. 4/F Zhi Fu Plazz, No.80 Xin Chang Road, Shanghai 200003, China Tel : +86-21-6120-0808
Germany	Mitsubishi Electric Europe B.V. German Branch Gothaer Strasse 8 D-40880 Ratingen, GERMANY Tel : +49-2102-486-0	Taiwan	Setsuyo Enterprise Co., Ltd. 6F No.105 Wu-Kung 3rd.Rd, Wu-Ku Hsiang, Taipei Hsine, Taiwan Tel : +886-2-2299-2499
U.K	Mitsubishi Electric Europe B.V. UK Branch Travellers Lane, Hatfield, Hertfordshire., AL10 8XB, U.K. Tel : +44-1707-276100	Korea	Mitsubishi Electric Automation Korea Co., Ltd. 1480-6, Gayang-dong, Gangseo-ku Seoul 157-200, Korea Tel : +82-2-3660-9552
Italy	Mitsubishi Electric Europe B.V. Italian Branch Centro Dir. Colleoni, Pal. Perseo-Ingr.2 Via Paracelso 12, I-20041 Agrate Brianza., Milano, Italy Tel : +39-039-60531	Singapore	Mitsubishi Electric Asia Pte. Ltd. 307 Alexandra Road #05-01/02, Mitsubishi Electric Building, Singapore 159943 Tel : +65-6470-2460
Spain	Mitsubishi Electric Europe B.V. Spanish Branch Carretera de Rubi 76-80, E-08190 Sant Cugat del Valles, Barcelona, Spain Tel : +34-93-565-3131	Thailand	Mitsubishi Electric Automation (Thailand) Co., Ltd. Bang-Chan Industrial Estate No.111 Moo 4, Serithai Rd, T.Kannayao, A.Kannayao, Bangkok 10230 Thailand Tel : +66-2-517-1326
France	Mitsubishi Electric Europe B.V. French Branch 25, Boulevard des Bouvets, F-92741 Nanterre Cedex, France Tel : +33-1-5568-5568	Indonesia	P.T. Autoteknindo Sumber Makmur Muara Karang Selatan, Block A/Utara No.1 Kav. No.11 Kawasan Industri Pergudangan Jakarta - Utara 14440, P.O.Box 5045 Jakarta, 11050 Indonesia Tel : +62-21-6630833
South Africa	Circuit Breaker Industries Ltd. Private Bag 2016, ZA-1600 Isando, South Africa Tel : +27-11-928-2000	India	Messung Systems Pvt. Ltd. Electronic Sadan NO:III Unit No15, M.I.D.C Bhosari, Pune-411026, India Tel : +91-20-2712-3130
		Australia	Mitsubishi Electric Australia Pty. Ltd. 348 Victoria Road, Rydalmere, N.S.W 2116, Australia Tel : +61-2-9684-7777

## MITSUBISHI ELECTRIC CORPORATION

HEAD OFFICE : TOKYO BUILDING, 2-7-3 MARUNOUCHI, CHYODA-KU, TOKYO 100-8310, JAPAN  
NAGOYA WORKS : 1-14, YADA-MINAMI 5-CHOME, HIGASHI-KU, NAGOYA, JAPAN

When exported from Japan, this manual does not require application to the Ministry of Economy, Trade and Industry for service transaction permission.

Specifications subject to change without notice.  
Printed in Japan, June 2011.