



# MAGNETIC MOTOR DRIVE UNIT

## MELIPM SERIES

# INSTRUCTION MANUAL

---

High Performance & High Function

---

## MD-CX522-0.4K to 3.7K

|                              |           |
|------------------------------|-----------|
| PRE-OPERATION<br>INFORMATION | Chapter 1 |
|------------------------------|-----------|

|              |           |
|--------------|-----------|
| INSTALLATION | Chapter 2 |
|--------------|-----------|

|        |           |
|--------|-----------|
| WIRING | Chapter 3 |
|--------|-----------|

|                                  |           |
|----------------------------------|-----------|
| HOW TO USE THE<br>PARAMETER UNIT | Chapter 4 |
|----------------------------------|-----------|

|           |           |
|-----------|-----------|
| OPERATION | Chapter 5 |
|-----------|-----------|

|                 |           |
|-----------------|-----------|
| TROUBLESHOOTING | Chapter 6 |
|-----------------|-----------|

|                |           |
|----------------|-----------|
| SPECIFICATIONS | Chapter 7 |
|----------------|-----------|

|                        |           |
|------------------------|-----------|
| PARAMETER<br>FUNCTIONS | Chapter 8 |
|------------------------|-----------|

## Please read here first

Thank you for choosing the Mitsubishi Magnetic Motor Drive Unit. This instruction manual gives handling information and precautions for use of the drive unit. Incorrect handling of the equipment may cause an unexpected fault. To optimize the unit capability, please read this manual carefully before using the equipment.

### General precautions

- Please forward this instruction manual to the end user.
- Many of the diagrams and drawings in this instruction manual show the drive unit without a cover, or partially open. Never run the drive unit in this manner. Always replace the cover and follow this instruction manual when operating the drive unit.
- After reading this manual, store it carefully in a place where it is easily accessible for the operator.
- This instruction manual is subject to modifications for specification changes and manual improvements. After such modifications have been made, the instruction manual will be published as a revised version with a new number located on the bottom left of the back cover.

### For safe operation of this product

- This product has not been designed or manufactured for use in or with a device or system which will be used under circumstances where life may be endangered.
- Consult with Mitsubishi if you are planning to use this product for special purposes, e.g. equipment or systems designed for manned transport vehicles, medical purposes, aerospace, nuclear power, electric power or undersea junctions.
- This product has been manufactured under strict quality control. However, when installing the product where serious accidents or losses could occur if the product fails, install appropriate safety devices in the system.
- Do not use this product with any load other than the specified motor.
- You cannot use a single drive unit with two or more motors.

## Please read here first (Continued)

### Safety Instructions

#### This section is specifically about safety matters

Do not attempt to install, operate, maintain or inspect the drive unit until you have read through this instruction manual and appended documents carefully and can use the equipment correctly. Do not use the drive unit until you have a full knowledge of the equipment, safety information and instructions.

In this instruction manual, the safety instruction levels are classified into "WARNING" and "CAUTION".



#### **WARNING**

Assumes that incorrect handling may cause hazardous conditions, resulting in severe injury or death.



#### **CAUTION**

Assumes that incorrect handling may cause hazardous conditions, resulting in medium or slight injury, or may cause physical damage only.

Note that the CAUTION level may lead to a serious consequence according to conditions. Please follow the instructions of both levels because they are important to personal safety.

**NOTICE** denotes the items which do not correspond to "WARNING" or "CAUTION" but should be observed by the customer.

**MEMO** denotes the items which the user should know for operation.

## 1. Usage

### **WARNING**

- The MELIPM series motor is a synchronous motor with high-performance magnets built in its rotor. Therefore, after the drive unit is powered off, there are high voltages at the motor terminals while the motor is running. Before starting wiring or maintenance and inspection, make sure that the motor has stopped. In any application where the motor is rotated by a load such as a fan or blower, connect a low-voltage manual switch on the drive unit's output side, open the switch, and start wiring or maintenance and inspection. Not doing so can cause an electric shock.
- Never disassemble or modify the unit. Doing so can cause an electric shock, fire or injury.
- Do not use the unit with any load other than the specified motor. Doing so can cause a fire or injury.
- Provide safety devices for the whole system, e.g. emergency brakes, to ensure that the machine or device is not placed in hazardous conditions when the drive unit fails.

### **CAUTION**

- If a holding brake is required, prepare it separately. Injury may result.
- Before operating the drive unit which had been stored for an extended period of time, perform inspection and test operation on the unit before using. Not doing so may cause accidents.

## 2. Transportation

### **CAUTION**

- Do not stack the drive unit boxes higher than the number indicated on the package. Doing so can cause injury.
- Confirm the weight before carrying the drive unit. Not doing so can cause injury.
- When carrying the drive unit, do not exert a force partially, i.e. do not hold the front cover. Doing so can cause the unit to drop, leading to injury.
- The drive unit is precision piece of equipment. Do not drop it or subject it to impact, this may damage the drive unit.

## 3. Installation

### **CAUTION**

- Do not install or operate the drive unit if it is damaged or has parts missing. Such installation or operation can cause accidents.
- Always install the drive unit in the specified orientation and environment. Not doing so can cause a fire or accidents.
- Install the drive unit on an incombustible material such as metal. Not doing so can cause a fire.
- Do not place combustible materials nearby. Doing so can cause a fire.
- Install the drive unit in a load-bearing place. Not doing so can cause accidents.
- Prevent screws, metal pieces or other conductive foreign matter, or wood scrap, oil or other flammable foreign matter from entering the drive unit. They can cause a fire or accidents.

## 4. Wiring

### **WARNING**

- Any person who is involved in the wiring of this equipment should be fully competent to do the work. Otherwise, an electric shock or fire can occur.
- Install a no-fuse breaker or earth leakage circuit breaker. Otherwise, a drive unit failure can cause large currents to flow, resulting in a fire.
- Always install the unit before wiring. Otherwise, an electric shock or fire can occur.
- Before restarting wiring after power-on, make sure that the motor is at a stop, wait for more than 10 minutes after switching power off, and confirm that the DC voltage across the DC terminals P/+ and N/- is low enough to do the work. Immediately after power-off, the DC terminals P/+, N/- are charged with more than 200V (residual voltage of the internal capacitor). Therefore, an electric shock may occur.
- Even after power-off, the motor connection terminals U, V, W have high voltages while the motor is running. Always start wiring after confirming that the motor has stopped. Not doing so can cause an electric shock.
- Earth the drive unit. Not doing so can cause an electric shock or fire.

### **CAUTION**

- Make sure that the input power supply voltage matches the rated voltage specifications. Mismatch can cause a fire or accidents.
- Check the terminal layout and terminal symbols to ensure that connections are correct. Wrong connections can cause a fire or accidents.
- Do not connect a power supply to the motor connection terminals U, V, W. Doing so can cause a fire or accidents.
- Connect the motor connection terminals U, V, W to match the motor phase sequence. Wrong connections can cause accidents due to reverse rotation of the motor.
- Do not connect a resistor across the DC terminals P/+-N/-. Doing so can cause a fire or accidents.
- Take measures to prevent peripheral sensors and equipment from malfunctioning due to electromagnetic noises. Not doing so can cause accidents.
- Take measures to prevent peripheral power capacitors and generators from overheating or being damaged due to power harmonics. Not doing so can cause a fire.
- Connect the power capacitor, surge suppressor and radio noise filter (FR-BIF option) on the power supply side. Connection on the output side can cause a fire.

## 5. Operation



### WARNING

- Always replace the front cover before switching input power on. While power is on, do not remove the front cover. Doing so can cause an electric shock.
- Operate the switches with dry hands. Not doing so can cause an electric shock.
- Prepare an emergency stop switch separately. The "STOP/RESET" key of the parameter unit is valid for stopping only when the function setting has been made. Not using a separate emergency stop switch can cause accidents.
- When the stall prevention function is activated, operation will be performed independently of the preset acceleration/deceleration time and preset speed. Design the machine to ensure safety if the stall prevention function is activated. Not doing so can cause accidents.
- At the occurrence of an alarm, turn off the run signal before resetting the alarm. The drive unit will restart abruptly if you reset the alarm with the run signal on. It can cause injury.
- At occurrence of an alarm, turn off the run signal. If you do not turn off the run signal, the alarm may be reset due to power OFF-ON at occurrence of an instantaneous power failure or like, restarting the drive unit suddenly. It can cause injury.



### CAUTION

- You can set the motor speed easily between low speed and high speed. Set the speed command which will not exceed the permissible range of machine design. Not doing so can cause accidents.
- If the motor is rotated by the load, ensure that the motor will not exceed its maximum speed. The drive unit may be damaged.
- While power is on or some time after power-off, do not touch the heat sink and brake resistor as they are hot. You may get burnt.
- The electronic overcurrent protection function for motor overheat protection is initialized when the drive unit is reset. Frequent resetting of the drive unit will disable motor overheat protection. The motor may be burnt if it is operated under overload.

## 6. Maintenance, Inspection and Part (Cooling Fan) Replacement



### WARNING

- Any person who is involved in maintenance, inspection or part replacement should be fully competent to do the work. Otherwise, an electric shock or injury can occur.
- Before starting maintenance, inspection or part replacement, make sure that the motor is at a stop, wait for more than 10 minutes after switching power off, and confirm that the DC voltage across the DC terminals P/+ and N/- is low enough to do the work. Immediately after power-off, the DC terminals P/+, N/- are charged with more than 200V (residual voltage of the internal capacitor). Therefore, an electric shock may occur.
- Even after power-off, the motor connection terminals U, V, W have high voltages while the motor is running. Always start the work after confirming that the motor has stopped. Not doing so can cause an electric shock.
- Do not conduct a pressure test. A pressure test can damage the drive unit.
- Do not perform an insulation resistance test on the control circuit using a megger. Such a test can damage the drive unit.
- While power is on, do not replace the cooling fan. Replacing the cooling fan during power-on can be hazardous.

## 7. Disposal



### CAUTION

- Dispose of the drive unit as general industrial waste. Its solder (lead) can cause environmental contamination.

## CONTENTS

|                                                                   | Page       |
|-------------------------------------------------------------------|------------|
| <b>1. PRE-OPERATION INFORMATION</b>                               | <b>1-1</b> |
| <b>1.1 Checking the Product</b>                                   | <b>1-1</b> |
| 1.1.1 Contents .....                                              | 1-1        |
| 1.1.2 Type .....                                                  | 1-1        |
| 1.1.3 Drive units to be used with motors .....                    | 1-1        |
| <b>1.2 Parts Identification</b>                                   | <b>1-2</b> |
| <b>1.3 Handling of Covers and the Like</b>                        | <b>1-3</b> |
| 1.3.1 Removal and reinstallation of the front cover (Lower) ..... | 1-3        |
| 1.3.2 Removal and reinstallation of the wiring cover .....        | 1-3        |
| 1.3.3 Removal and reinstallation of the operation panel .....     | 1-4        |
| <b>1.4 Transportation</b>                                         | <b>1-5</b> |
| <b>1.5 Storage</b>                                                | <b>1-5</b> |
| <b>2. INSTALLATION</b>                                            | <b>2-1</b> |
| <b>2.1 Checking the Installation Environment</b>                  | <b>2-1</b> |
| 2.1.1 Operating environment .....                                 | 2-1        |
| 2.1.2 Installation in control box .....                           | 2-2        |
| <b>2.2 Preparation of Peripheral Devices</b>                      | <b>2-3</b> |
| 2.2.1 Basic configuration .....                                   | 2-3        |
| 2.2.2 Selection of peripheral devices .....                       | 2-4        |
| <b>2.3 Installation Method</b>                                    | <b>2-6</b> |
| <b>3. WIRING</b>                                                  | <b>3-1</b> |
| <b>3.1 Pre-Wiring Instructions</b>                                | <b>3-2</b> |
| 3.1.1 Terminal connection diagram .....                           | 3-2        |
| <b>3.2 Wiring of the Main Circuit Terminals</b>                   | <b>3-3</b> |
| 3.2.1 Terminals .....                                             | 3-3        |
| 3.2.2 Terminal layout and connection specifications .....         | 3-3        |
| 3.2.3 Wiring of the AC power input terminals R, S, T .....        | 3-3        |



|                                                                                                                              |     |
|------------------------------------------------------------------------------------------------------------------------------|-----|
| 3.2.4 Wiring of the motor connection terminals U, V, W .....                                                                 | 3-4 |
| 3.2.5 Wiring of the ground terminals  ..... | 3-4 |
| 3.2.6 Wiring of the DC reactor connection terminals P/+, P1 .....                                                            | 3-5 |
| 3.2.7 Wiring of the brake resistor connection terminals P/+, PR .....                                                        | 3-5 |
| 3.2.8 Wiring of the DC terminals P/+, N/- .....                                                                              | 3-5 |

### **3.3 Wiring of the Control Circuit Terminals 3-6**

|                                                           |      |
|-----------------------------------------------------------|------|
| 3.3.1 Terminals.....                                      | 3-6  |
| 3.3.2 Terminal layout and connection specifications ..... | 3-9  |
| 3.3.3 Wiring of the contact input terminals .....         | 3-10 |
| 3.3.4 Wiring of the speed command input terminals .....   | 3-11 |
| 3.3.5 Wiring of the transistor output terminals .....     | 3-11 |
| 3.3.6 Wiring of the contact output terminals .....        | 3-12 |
| 3.3.7 Wiring of the instrument connection terminals.....  | 3-12 |

### **3.4 Wiring of the PU Connector 3-13**

|                                                                           |      |
|---------------------------------------------------------------------------|------|
| 3.4.1 Pin layout.....                                                     | 3-13 |
| 3.4.2 Using the cable to connect the parameter unit .....                 | 3-13 |
| 3.4.3 System configuration examples<br>for communication operations ..... | 3-13 |
| 3.4.4 Wiring methods for communication operation .....                    | 3-15 |

## **4. HOW TO USE THE FR-PU04 PARAMETER UNIT 4-1**

## **5. OPERATION 5-1**

### **5.1 Power On 5-1**

### **5.2 Setting of Operation Mode 5-1**

### **5.3 Starting operation 5-2**

## **6. TROUBLESHOOTING 6-1**

### **6.1 Message Appearing on the Parameter Unit 6-1**

|                                          |     |
|------------------------------------------|-----|
| 6.1.1 Protective function activated..... | 6-1 |
| 6.1.2 Alarm function activated .....     | 6-4 |
| 6.1.3 Others.....                        | 6-5 |

### **6.2 Motor operation out of ordinary 6-6**

|                                                                              |             |
|------------------------------------------------------------------------------|-------------|
| <b>6.3 Maintenance and Inspection</b>                                        | <b>6-7</b>  |
| 6.3.1 Inspection .....                                                       | 6-7         |
| 6.3.2 Wear parts .....                                                       | 6-9         |
| 6.3.3 Cooling fan replacement method .....                                   | 6-10        |
| <b>7. SPECIFICATIONS</b>                                                     | <b>7-1</b>  |
| <b>7.1 Standard Specifications</b>                                           | <b>7-1</b>  |
| 7.1.1 Rating specifications .....                                            | 7-1         |
| 7.1.2 Common specifications .....                                            | 7-2         |
| 7.1.3 Outline drawings.....                                                  | 7-4         |
| <b>8. PARAMETER FUNCTIONS</b>                                                | <b>8-1</b>  |
| <b>8.1 Protection and Editing of the Parameters</b>                          | <b>8-1</b>  |
| <b>8.2 Parameter Unit Operation Selection</b>                                | <b>8-2</b>  |
| <b>8.3 Selection of the Speed Command</b>                                    | <b>8-3</b>  |
| 8.3.1 Selection of the analog speed command specifications.....              | 8-3         |
| 8.3.2 Variable-speed operation using contact input signals .....             | 8-4         |
| <b>8.4 Selection of the Control Circuit Contact Input Terminal Functions</b> | <b>8-5</b>  |
| <b>8.5 Setting of the Operation Pattern</b>                                  | <b>8-6</b>  |
| 8.5.1 Running speed region .....                                             | 8-6         |
| 8.5.2 Acceleration time and deceleration time .....                          | 8-8         |
| 8.5.3 Selection of regenerative brake unit.....                              | 8-9         |
| 8.5.4 Stall prevention operation level .....                                 | 8-9         |
| 8.5.5 Other settings .....                                                   | 8-10        |
| <b>8.6 Communication operation from the PU connector</b>                     | <b>8-11</b> |
| <b>8.7 Monitoring of Operation Status</b>                                    | <b>8-22</b> |
| 8.7.1 Selection of parameter unit display data .....                         | 8-22        |
| 8.7.2 Selection of the control circuit output terminal functions .....       | 8-23        |
| 8.7.3 Detection of running speed .....                                       | 8-23        |
| 8.7.4 Detection of output current.....                                       | 8-24        |
| 8.7.5 Selection of the instrument connection terminal functions .....        | 8-25        |
| <b>APPENDIX 1 PARAMETER LIST (NUMERICAL ORDER)</b>                           | <b>8-26</b> |

# 1. PRE-OPERATION INFORMATION

## 1.1 Checking the Product

Unpack the drive unit, inspect the contents, and check the name plate to ensure that the product agrees with your order.

### 1.1.1 Contents

| Contents           | Quantity |
|--------------------|----------|
| Drive unit         | 1        |
| Instruction manual | 1        |

### 1.1.2 Type

- Locations of the capacity plate and name plate and definitions of their descriptions

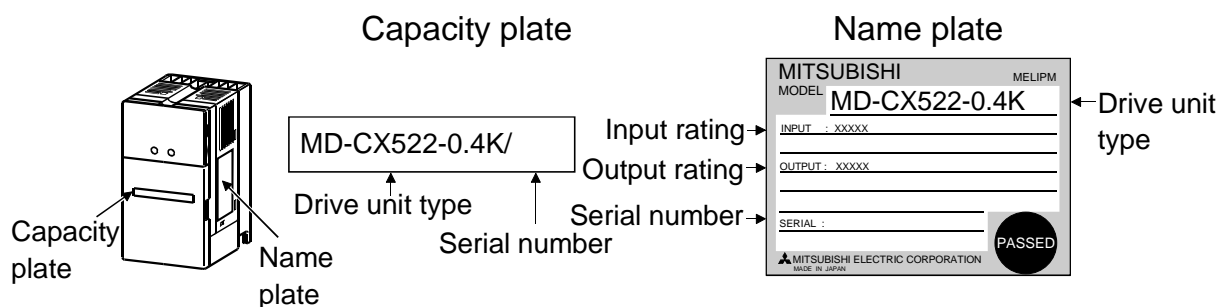

- Type

MD - CX 5 2 2 - □ □ K

Series | Capacity

Power supply: 3-phase 200V

### 1.1.3 Drive units to be used with motors

Use the drive unit with the specified dedicated motor. In this case, confirm that the capacity and rated speed of the drive unit always match those of the motor.

## 1.2 Parts Identification

● Appearance of drive unit

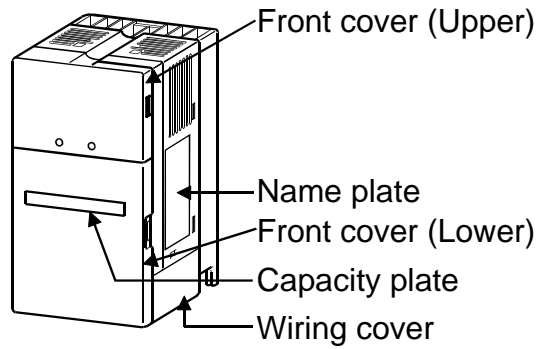

● Without front cover (Lower)

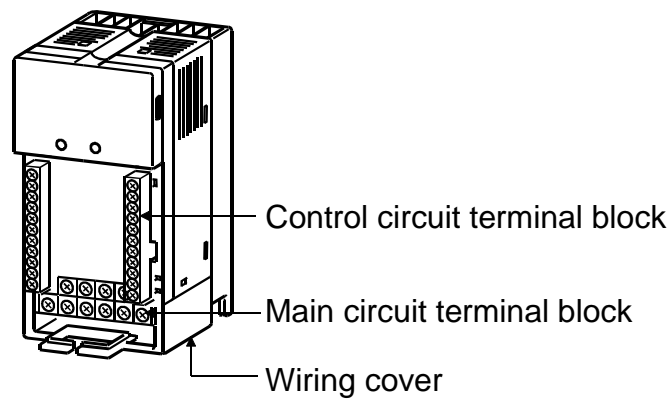

● Without front cover (Upper)

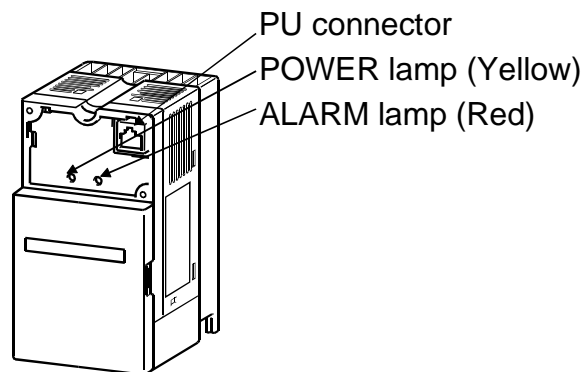

## 1.3 Handling of Covers and the Like

### 1.3.1 Removal and reinstallation of the front cover (Lower)

The front cover is fastened by the latches in positions A and B. Push either A or B in the direction of arrow, and using the other end as a support, pull the front cover toward you to remove.

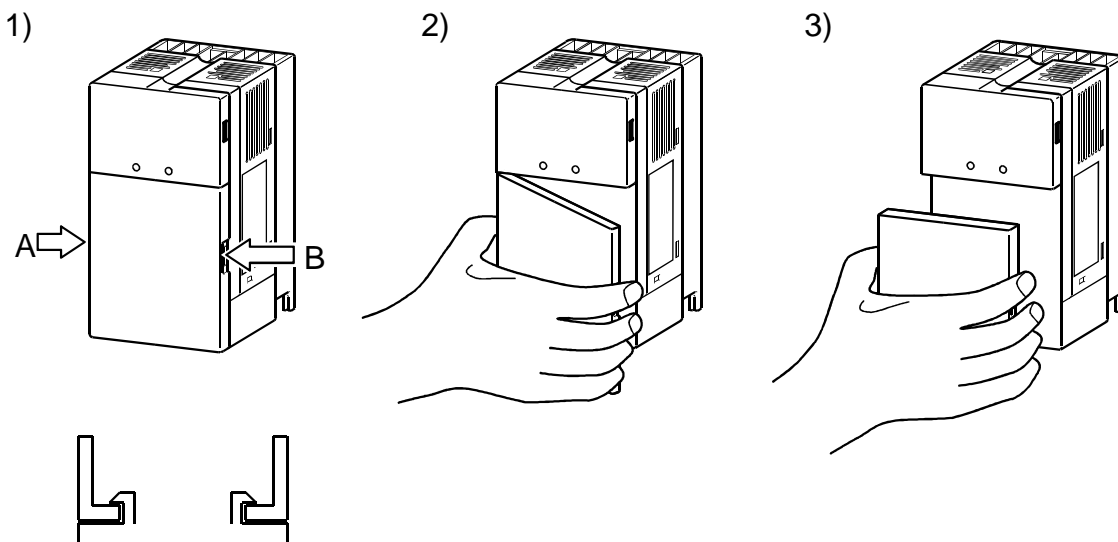

To reinstall the front cover, fasten it with the latches securely.

### 1.3.2 Removal and reinstallation of the wiring cover

The wiring cover is fastened by the latches in positions 1 and 2. Push either 1 or 2 in the direction of arrow, and pull the wiring cover downward to remove.

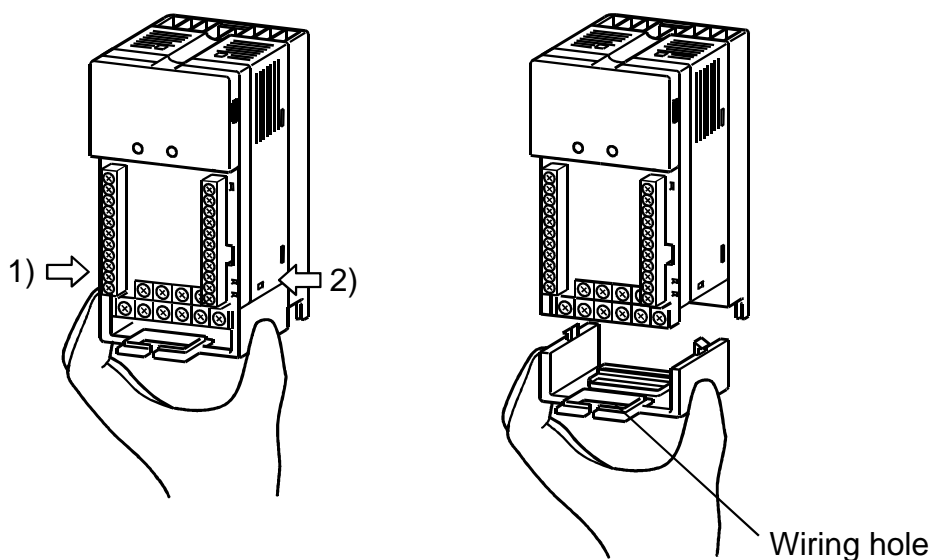

Run the cables through the wiring hole and reinstall the cover securely in the original position.

### 1.3.3 Removal and reinstallation of the operation panel

Hold down the arrow part A, and using the arrow part B as a support, pull the right hand side of the operation panel toward you and remove the panel rightward.

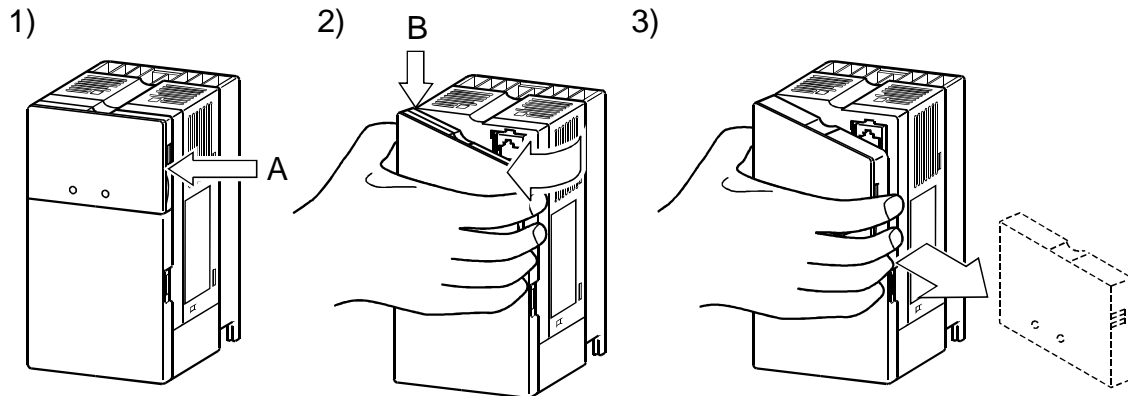

If the operation panel is removed in any other method, force will be applied to the internal connector, damaging the panel.

To reinstall, insert the tab (left side) of the operation panel into the mounting position of the drive unit and push in the right hand side tab.

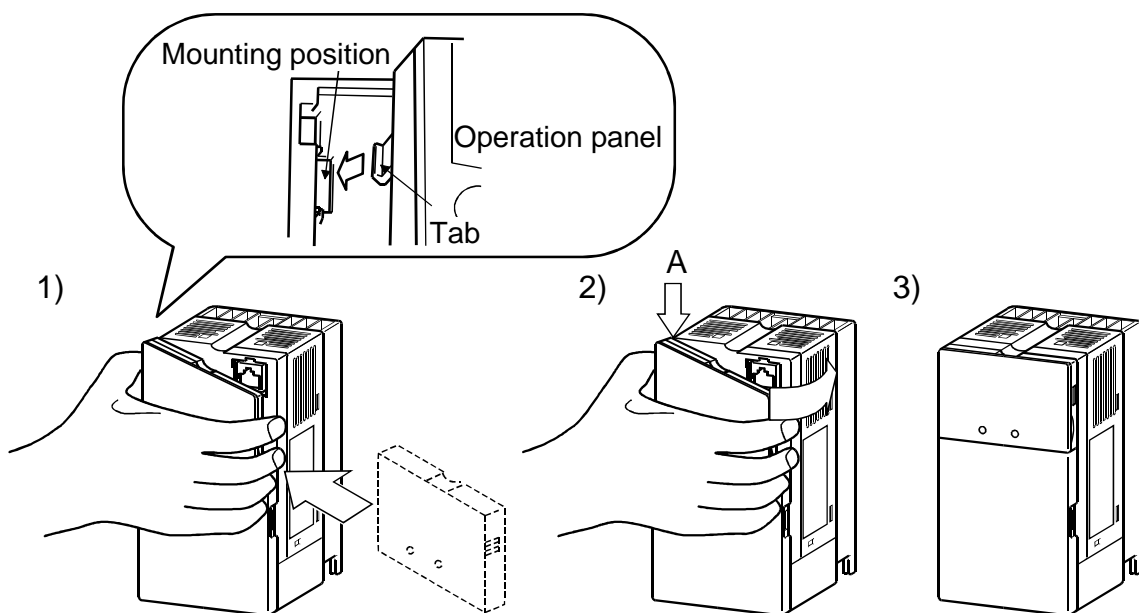

## 1.4 Transportation

When carrying, always support the whole drive unit.

## 1.5 Storage

Store the drive unit in the following environment.

|                            |                                                                                                       |
|----------------------------|-------------------------------------------------------------------------------------------------------|
| <b>Ambience</b>            | No corrosive gas, flammable gas, oil mist, dust and dirt.<br>No exposure to direct sunlight. No salt. |
| <b>Ambient temperature</b> | -10°C to +50°C (non-freezing)                                                                         |
| <b>Storage temperature</b> | -20°C to +65°C (applies to short-time transit)                                                        |
| <b>Ambient humidity</b>    | 90%RH or less (non-condensing)                                                                        |
| <b>Vibration</b>           | 5.9m/s <sup>2</sup> (conformance with JIS C 0040)                                                     |

|               |                                                                                                                                                                                                                                                                                                                                |
|---------------|--------------------------------------------------------------------------------------------------------------------------------------------------------------------------------------------------------------------------------------------------------------------------------------------------------------------------------|
| <b>NOTICE</b> | <ul style="list-style-type: none"> <li>● If the specification value of humidity is satisfied, condensation and/or freezing will occur in places where temperatures vary greatly. Avoid storing the equipment in such places.</li> <li>● Avoid placing the unit directly on the floor. Place it on a stand or shelf.</li> </ul> |
|---------------|--------------------------------------------------------------------------------------------------------------------------------------------------------------------------------------------------------------------------------------------------------------------------------------------------------------------------------|

## 2. INSTALLATION

This chapter gives preparatory information on installation and wiring of the drive unit.

|               |                                                                                                                                                                                                                                                                                                                                                                                                                                                                                                                                                                         |
|---------------|-------------------------------------------------------------------------------------------------------------------------------------------------------------------------------------------------------------------------------------------------------------------------------------------------------------------------------------------------------------------------------------------------------------------------------------------------------------------------------------------------------------------------------------------------------------------------|
| <b>NOTICE</b> | <ul style="list-style-type: none"> <li>● The Japanese harmonic suppression guidelines for suppression of harmonics were established by the Ministry of Economy, Trade and Industry (formerly Ministry of International Trade and Industry) in September, 1994.<br/>To comply with the regulation levels determined by the Japan Electrical Manufacturers' Association in accordance with the "harmonic suppression guideline for household appliances and general-purpose products", connect the optional power factor improving reactor (FR-BEL or FR-BAL).</li> </ul> |
|---------------|-------------------------------------------------------------------------------------------------------------------------------------------------------------------------------------------------------------------------------------------------------------------------------------------------------------------------------------------------------------------------------------------------------------------------------------------------------------------------------------------------------------------------------------------------------------------------|

### 2.1 Checking the Installation Environment

#### 2.1.1 Operating environment

- General operating environment  
Install the unit in the following environment.

|                            |                                                                                                                |
|----------------------------|----------------------------------------------------------------------------------------------------------------|
| <b>Ambience</b>            | Indoors (No corrosive gas, flammable gas, oil mist, dust and dirt<br>No exposure to direct sunlight. No salt.) |
| <b>Ambient temperature</b> | -10°C to +50°C (non-freezing)                                                                                  |
| <b>Ambient humidity</b>    | 90%RH or less (non-condensing)                                                                                 |
| <b>Altitude</b>            | Maximum 1000m                                                                                                  |
| <b>Vibration</b>           | 5.9m/s <sup>2</sup> (conformance with JIS C 0040)                                                              |

#### CAUTION

- Install the equipment on a non-flammable material. Not doing so can cause a fire.
- Do not place flammable materials near the equipment. Doing so can cause a fire.
- Install the unit in a load-bearing place. Not doing so can cause an accident.

- Noise environment

Since drive is an electronic piece of equipment, the drive unit may malfunction if there are machines which generate large noises (e.g. welder, power equipment) in the periphery. Fit surge suppressors, noise filters and/or like to the noise sources, install the drive unit as far away as possible from noise sources, or place shielding plates and the like to fully suppress noises.

#### CAUTION

- The drive unit itself can be the source of noises. Take noise suppression measures to prevent peripheral equipment from malfunctioning due to noises.



### 2.1.2 Installation in control box

When installing the drive unit in a control box, the internal temperature of the control box must not exceed the permissible value due to drive-unit generated heat and peripheral-generated heat.

Placing a heat sink outside the control box can reduce the heat generated inside the control box.

● Measurement positions of ambient temperatures

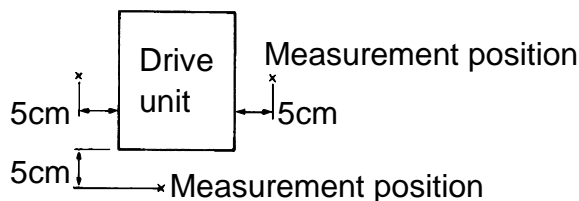

● Layout of drive units within control box

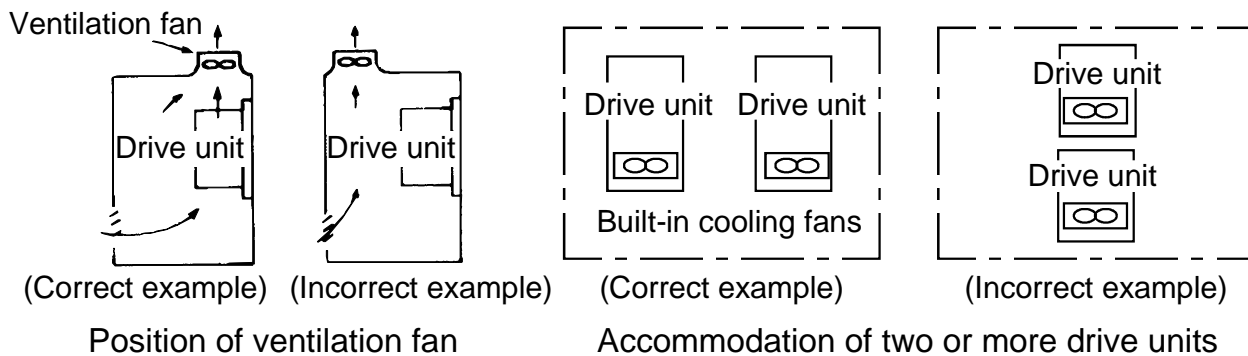

● Leave the specified clearances between the drive unit and control box walls or other equipment. Not doing so can cause a failure. In addition, improper convection of air in the control box will reduce the heat dissipation effect. Fully consider the equipment layout in the control box and the use of a cooling fan for ventilation, for example.

**NOTICE**

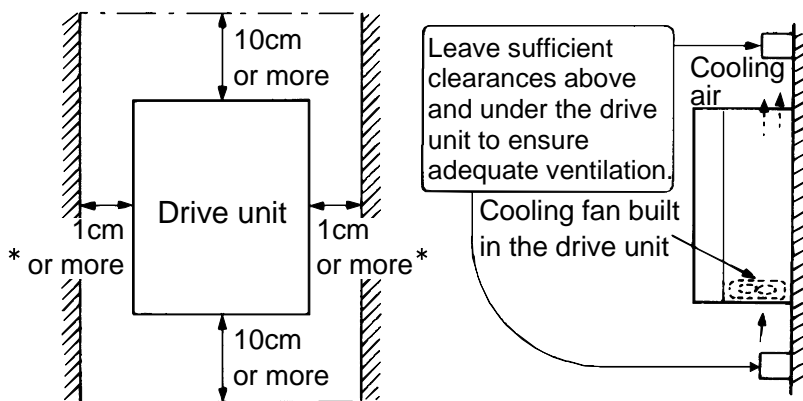

\* These clearances are also required for replacement of the cooling fan.

## 2.2 Preparation of Peripheral Devices

### 2.2.1 Basic configuration

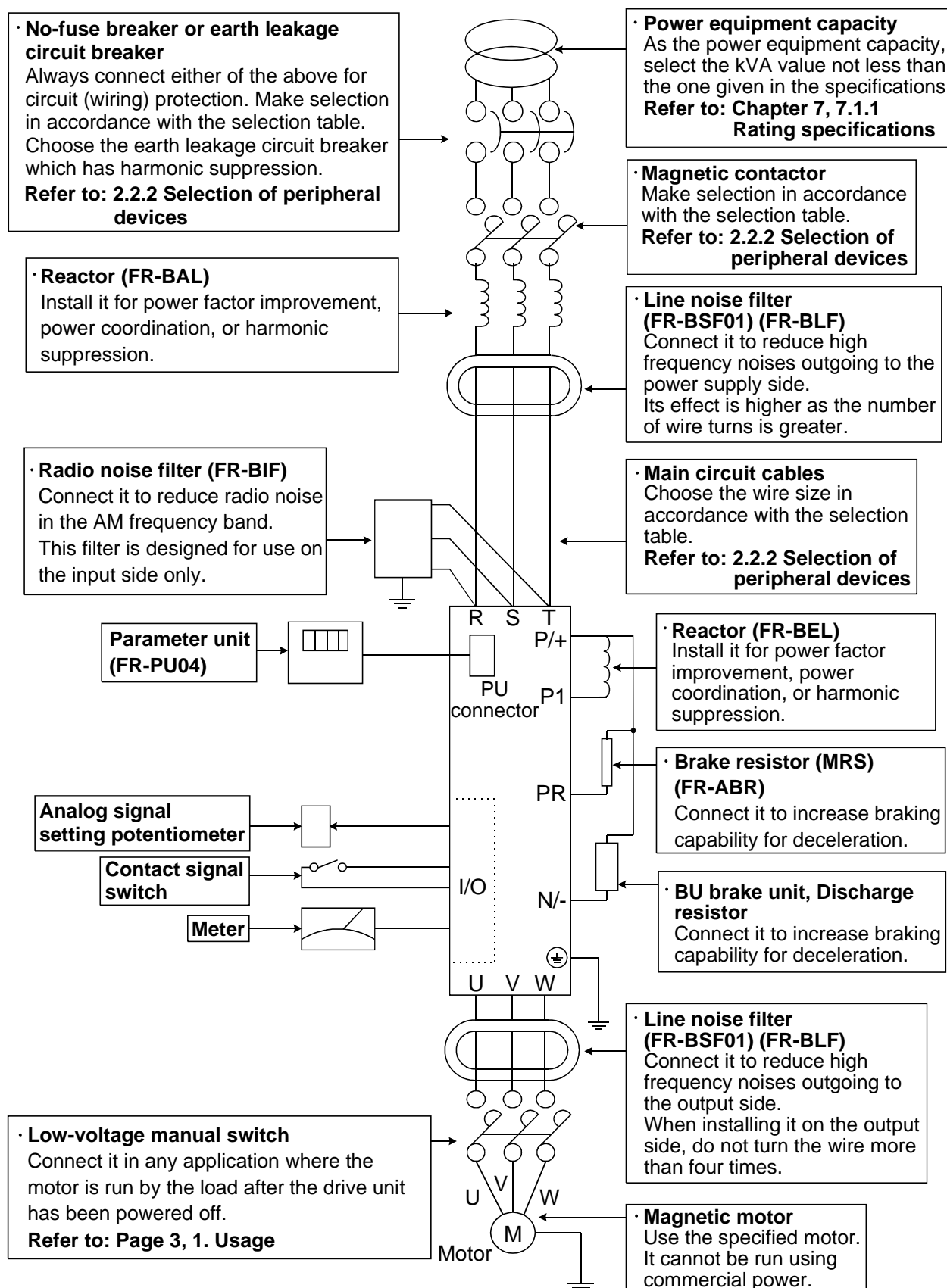

## 2.2.2 Selection of peripheral devices

### (1) Wire size

- AC power input terminals R, S, T, motor connection terminals U, V, W, DC reactor connection terminals P/+, P1, DC terminals P/+, N/-, ground terminals

| Capacity (K) | Terminal Screw Size | Wire Sizes, Unit: mm <sup>2</sup> |          |              |            | Wire Type                                 |
|--------------|---------------------|-----------------------------------|----------|--------------|------------|-------------------------------------------|
|              |                     | R, S, T                           | U, V, W  | P/+, P1, N/- | Connection |                                           |
| 0.4          | M3.5                | 2                                 | 2        | 2            | 2          | Power cable 600V vinyl wire or equivalent |
| 0.75         |                     |                                   |          |              |            |                                           |
| 1.5          | M4                  | 2 to 5.5                          | 2 to 5.5 | 2 to 5.5     | 2 to 5.5   |                                           |
| 2.2          |                     |                                   |          |              |            |                                           |
| 3.7          |                     |                                   |          |              |            |                                           |

- Control circuit terminals (all terminals)

| Capacity       | Terminal Screw Size | Wire Size, Unit: mm <sup>2</sup> | Wire Type                                                                                  |
|----------------|---------------------|----------------------------------|--------------------------------------------------------------------------------------------|
| All capacities | M2.5                | 0.3 to 0.75                      | Twisted shielded wire, polyethylene insulated vinyl wire for instrumentation or equivalent |

|             |                                                                                                                                      |
|-------------|--------------------------------------------------------------------------------------------------------------------------------------|
| <b>MEMO</b> | ● Refer to the corresponding instruction manual for wires connection of a stand-alone option connected to the DC terminals P/+, N/-. |
|-------------|--------------------------------------------------------------------------------------------------------------------------------------|

|               |                                                                                                                                                                                                                                                                                                                                                                                                                                                                                                                                                                                  |
|---------------|----------------------------------------------------------------------------------------------------------------------------------------------------------------------------------------------------------------------------------------------------------------------------------------------------------------------------------------------------------------------------------------------------------------------------------------------------------------------------------------------------------------------------------------------------------------------------------|
| <b>NOTICE</b> | <ul style="list-style-type: none"> <li>● Choose the size of the wires connected to the motor connection terminals so that a voltage drop due to the wires is less than 4V. The minimum wire size in the above selection table assumes that the wiring length is less than 20m. A voltage drop can be found by the following expression:<br/>Line voltage drop (mV) = <math>\sqrt{3} \times \text{wire resistance } (\Omega/\text{km}) \times \text{wiring length (m)} \times \text{current (A)}</math></li> <li>● Use the ground cable which is as thick as possible.</li> </ul> |
|---------------|----------------------------------------------------------------------------------------------------------------------------------------------------------------------------------------------------------------------------------------------------------------------------------------------------------------------------------------------------------------------------------------------------------------------------------------------------------------------------------------------------------------------------------------------------------------------------------|

### (2) Crimping terminals

| Wire Size, Unit: mm <sup>2</sup> | Terminal Screw Size | Crimping Terminal Size |
|----------------------------------|---------------------|------------------------|
| 2                                | M3.5                | 2-3.5                  |
|                                  | M4                  | 2-4                    |
| 3.5/5.5                          | M4                  | 5.5-4                  |

**(3) No-fuse breakers, magnetic contactors**

| Capacity (K) | No-Fuse Breaker                     |                                        | Magnetic Contactor                  |
|--------------|-------------------------------------|----------------------------------------|-------------------------------------|
|              | With power factor improving reactor | Without power factor improving reactor | With power factor improving reactor |
| 0.4          | 30AF/5A                             |                                        | S-N10                               |
| 0.75         | 30AF/10A                            |                                        |                                     |
| 1.5          | 30AF/15A                            |                                        |                                     |
| 2.2          | 30AF/15A                            | 30AF/20A                               | S-N11, S-N12                        |
| 3.7          | 30AF/30A                            |                                        | S-N20                               |

If the magnetic contactor does not have power factor improving reactor, select the magnetic contactor as indicated in the following table depending on the power equipment capacity and the wiring length from the power equipment to the drive unit.

| Power Supply Capacity | Less than 50kVA | 50kVA or More |            |               |
|-----------------------|-----------------|---------------|------------|---------------|
| Wiring length         | —               | 20m or more   | 10m to 20m | Less than 10m |
| Capacity (K)          | 0.4             | S-N18         | S-N21      | S-N21         |
|                       | 0.75            |               |            |               |
|                       | 1.5             | S-N21         | S-N25      | S-N50         |
|                       | 2.2             | S-N11, S-N12  |            |               |
|                       | 3.7             | S-N20         |            |               |

**(4) Earth leakage circuit breakers**

## ● Selection method

Use the earth leakage circuit breaker which has harmonic/surge suppression.  
Our product: Progressive Super Series NV-SF, NV-CF

| Capacity (K) | Earth Leakage Circuit Breaker       |                                        |
|--------------|-------------------------------------|----------------------------------------|
|              | With power factor improving reactor | Without power factor improving reactor |
| 0.4          | 30AF/5A                             |                                        |
| 0.75         | 30AF/10A                            |                                        |
| 1.5          | 30AF/15A                            |                                        |
| 2.2          | 30AF/15A                            | 30AF/20A                               |
| 3.7          | 30AF/30A                            |                                        |

|             |                                                                                                                                                                                                                                                                                                                                                                                                                                                                                                           |
|-------------|-----------------------------------------------------------------------------------------------------------------------------------------------------------------------------------------------------------------------------------------------------------------------------------------------------------------------------------------------------------------------------------------------------------------------------------------------------------------------------------------------------------|
| <b>MEMO</b> | <p>● Leakage currents from the wiring and motor include frequency components of a higher degrees than those from the commercial power supply. Therefore, the earth leakage circuit breaker which is not a harmonic/surge suppression product can cause unnecessary operations.</p> <p>&lt;Measures against unnecessary operations&gt;</p> <ul style="list-style-type: none"> <li>• Minimize the wiring distance of I/O cables.</li> <li>• Run I/O cables away (more than 30cm) from the earth.</li> </ul> |
|-------------|-----------------------------------------------------------------------------------------------------------------------------------------------------------------------------------------------------------------------------------------------------------------------------------------------------------------------------------------------------------------------------------------------------------------------------------------------------------------------------------------------------------|

## 2.3 Installation Method

- 1) Remove the front covers. (Upper and lower)
- 2) Remove the wiring cover.
- 3) Pass screws or bolts into the four mounting holes and secure the drive unit.  
(Three mounting holes for 0.75K or less)

### CAUTION

- Prevent screws, metal pieces and other conductive foreign matter and oil and other flammable foreign matter from entering the drive unit.
- Securely screw or bolt the unit to the mounting surface vertically without looseness. Always install the unit in the specified mounting orientation. Not doing so can cause a failure.

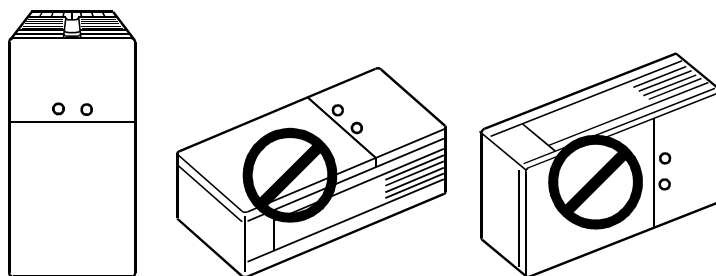

- Do not drop the unit, or subject it to impact.

- 4) Replace the removed cover. Leave the cover removed when continuing the wiring work.

### NOTICE

- Fully check that the front cover has been mounted securely. Insecure mounting can cause a drop due to vibration.
- The front cover (Lower) is fitted with the capacity plate and the drive unit with the name plate. The same serial number is printed on these plates. Always reinstall the cover to the drive unit from where it had been removed.

## 3. WIRING

This chapter describes the wiring of the drive unit.

### WARNING

- Any person who is involved in the wiring of this equipment should be fully competent to do the work. Otherwise, an electric shock or fire can occur.
- Always install the unit before wiring. Otherwise, an electric shock or fire can occur.
- Before restarting wiring after switching power "ON", make sure that the motor is at a stop, wait for more than 10 minutes after switching power "OFF", and confirm that the DC voltage across the DC terminals P/+ and N/- is low enough to do wiring. Immediately after power "OFF", the DC terminals P/+, N/- are charged with more than 200V (residual voltage of the internal capacitor). Therefore, an electric shock may occur.
- Even after power-off, the motor connection terminals U, V, W have high voltages while the motor is running. Always start wiring after confirming that the motor has stopped. Not doing so can cause an electric shock.

### CAUTION

- Take measures to prevent peripheral sensors and equipment from malfunctioning due to electromagnetic noises. Not doing so can cause accidents.
- Take measures to prevent peripheral power capacitors and generators from overheating or being damaged due to power harmonics. Not doing so can cause a fire.
- Do not leave wire offcuts in the drive unit. Doing so can cause a fault, failure or malfunction.
- If the machine must not be restarted when power is restored after a power failure, provide a magnetic contactor on the power supply side and also make up a sequence which will not turn "ON" the start signal automatically when power is restored.
- Tighten the terminal screws to the specified torque. Undertightening can cause an inter-terminal short circuit or malfunction. Overtightening can cause the screws and unit to be damaged, resulting in a short circuit, malfunction or the like.

## 3.1 Pre-Wiring Instructions

### 3.1.1 Terminal connection diagram

The following shows the wiring of all terminals. After confirming the function of each terminal, wire necessary terminals according to your application. When the Parameter unit is used to perform operation, merely doing the main circuit wiring enables the motor to run.

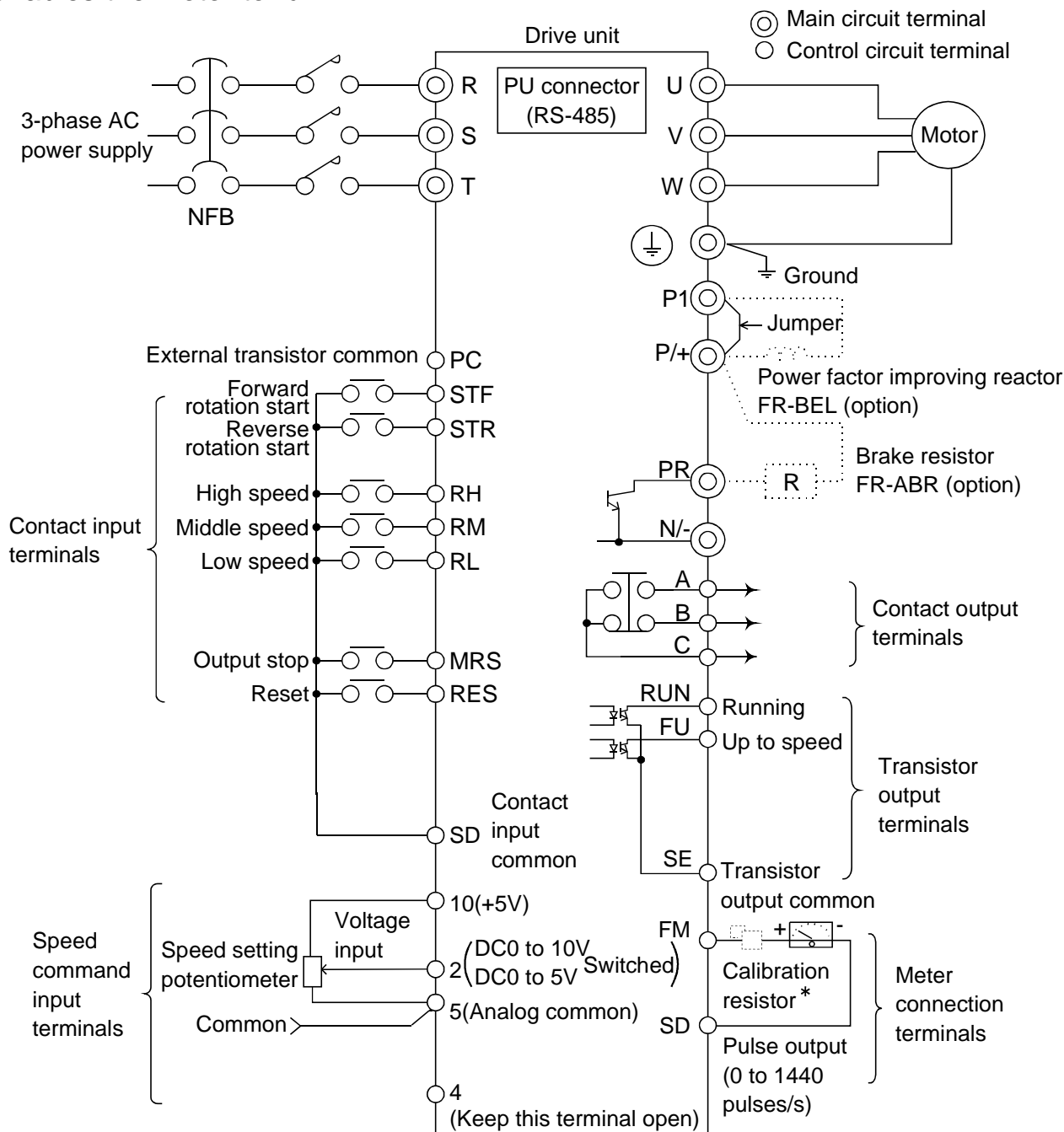

\*This resistor is not needed when you use the parameter unit (FR-PU04) to make calibration. This resistor is used when you need to calibrate the meter nearby because the meter is at a remote location, for example. Note that when you connect the calibration resistor, the meter may not deflect to the full scale. In this case, use the parameter unit with the resistor to make calibration.

## 3.2 Wiring of the Main Circuit Terminals

### 3.2.1 Terminals

| Symbols                                                                           | Name                                | Description                                                                                                      |
|-----------------------------------------------------------------------------------|-------------------------------------|------------------------------------------------------------------------------------------------------------------|
| R, S, T                                                                           | AC power input terminals            | Connect to the commercial power supply.                                                                          |
| U, V, W                                                                           | Motor connection terminals          | Connect to a dedicated variable-speed synchronous motor.                                                         |
| P/+, PR                                                                           | Brake resistor connection terminals | Connect the brake resistor (option).                                                                             |
| P/+, P1                                                                           | DC reactor connection terminals     | Disconnect the jumper from terminals P/+ - P1 and connect the FR-BEL power factor improving DC reactor (option). |
| P/+, N/-                                                                          | DC terminals                        | Connect to the BU brake unit (option).                                                                           |
|  | Ground terminals                    | Terminals for connection of the ground cables. (There are two terminals.)                                        |

### 3.2.2 Terminal layout and connection specifications

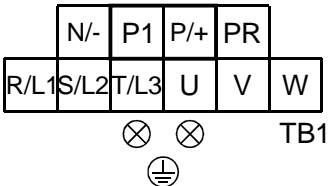
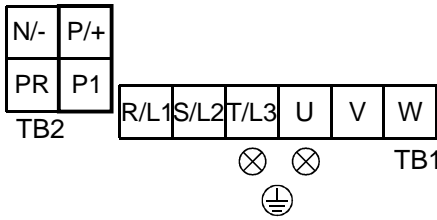
| CX522-0.4, 0.75K   |                                                                                    | CX522-1.5K to 3.7K |                                                                                     |
|--------------------|------------------------------------------------------------------------------------|--------------------|-------------------------------------------------------------------------------------|
| Layout             |  | Layout             |  |
| Screw size<br>M3.5 | Tightening torque<br>1.2N•m                                                        | Screw size<br>M4   | Tightening torque<br>1.5N•m                                                         |

#### CAUTION

- Tighten the terminal screws to the specified torque. Undertightening can cause an inter-terminal short circuit or malfunction. Overtightening can cause the screws and unit to be damaged, resulting in a short circuit malfunction or the like.

### 3.2.3 Wiring of the AC power input terminals R, S, T

Connect these terminals to the AC power supply. You need not match the phase sequence.

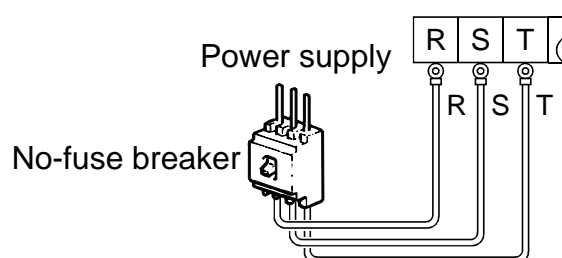

#### CAUTION

- Always apply power to only the AC power input terminals R, S, T. Applying power to the other terminals will damage the unit.



### 3.2.4 Wiring of the motor connection terminals U, V, W

Connect these terminals to the motor. Match the phase sequence of the motor connection terminals U, V, W with that of the motor cables. Incorrect phase sequence will run the motor in reverse.

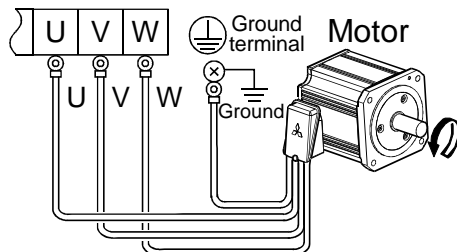

|                                                                                                                                                                                                                                                                                                                                                                           |
|---------------------------------------------------------------------------------------------------------------------------------------------------------------------------------------------------------------------------------------------------------------------------------------------------------------------------------------------------------------------------|
| <b>CAUTION</b>                                                                                                                                                                                                                                                                                                                                                            |
| <ul style="list-style-type: none"> <li>● The wiring length between the drive unit and motor should be 100m maximum. Long wiring may cause torque to be insufficient or the overcurrent protection function to be activated.</li> <li>● Between the drive unit and motor, do not fit a power capacitor, surge suppressor or FR-BIF radio noise filter (option).</li> </ul> |

### 3.2.5 Wiring of the ground terminals

There are two ground terminals. Connect one ground terminal to the motor's ground terminal and perform shared grounding on the drive unit.

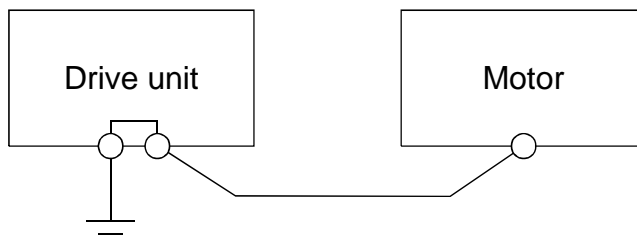

|                                    |                                                                                                                                                                            |
|------------------------------------|----------------------------------------------------------------------------------------------------------------------------------------------------------------------------|
| <b>NOTICE</b>                      | <ul style="list-style-type: none"> <li>● Avoid shared grounding with the other equipment susceptible to noise, and perform exclusive or single-point grounding.</li> </ul> |
|                                    |                                                                                                                                                                            |
|                                    | Shared grounding<br>... Not allowed                                                                                                                                        |
|                                    |                                                                                                                                                                            |
| Exclusive grounding<br>... Allowed |                                                                                                                                                                            |
|                                    |                                                                                                                                                                            |
| 1-point grounding<br>... Allowed   |                                                                                                                                                                            |

|                                                                                                                                                                                                                                                                                                                                                 |
|-------------------------------------------------------------------------------------------------------------------------------------------------------------------------------------------------------------------------------------------------------------------------------------------------------------------------------------------------|
| <b>WARNING</b>                                                                                                                                                                                                                                                                                                                                  |
| <ul style="list-style-type: none"> <li>● Ground the drive unit and motor securely to prevent an electric shock due to leakage currents. (Class D grounding, grounding resistance 100Ω max.)</li> <li>● For grounding, connect the cable to the exclusive ground terminal. (Do not use the screw of the casing, chassis or the like.)</li> </ul> |

### 3.2.6 Wiring of the DC reactor connection terminals P/+, P1

These terminals are designed for connection of the power factor improving reactor (FR-BEL).

Remove the jumper across the terminals P/+ - P1 and connect the DC reactor.

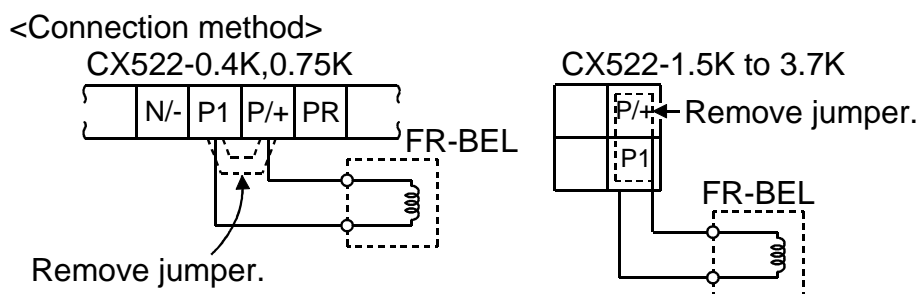

**NOTICE** ● The wiring distance (overall length) should be within 5m.

**MEMO** ● Without removal of the jumper, the reactor will not be active.

### 3.2.7 Wiring of the brake resistor connection terminals P/+, PR

These terminals are designed for connection to the brake resistor (heavy-duty brake resistor).

Change Pr. 30 and Pr. 70 settings before use.

**NOTICE** ● Connect only the specified brake resistor.

### 3.2.8 Wiring of the DC terminals P/+, N/-

These terminals are designed for connection of the BU brake unit.

- 1) Connect the BU brake unit. For full information, read the BU brake unit instruction manual.
- 2) Change the Pr. 30 setting.

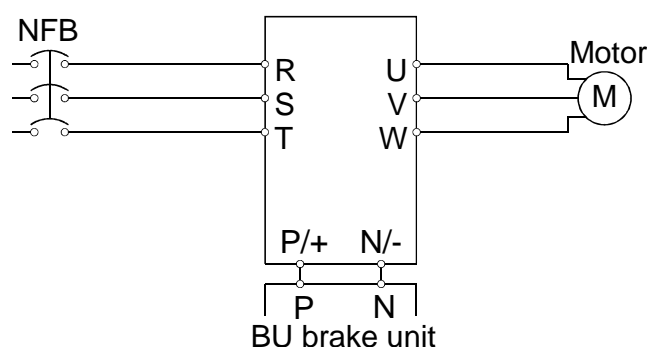

#### ⚠ CAUTION

- Do not connect the brake resistor or the like to the DC terminals P/+, N/- directly. Doing so can cause a fire.
- Incorrect (opposite) connection to the DC terminals P/+, N/- will damage the drive unit.

### 3.3 Wiring of the Control Circuit Terminals

#### ⚠ CAUTION

- Use shielded or twisted cables for wiring the control circuit input terminals. Also run them away from the main circuit wiring and other power cables. Not doing so can cause a malfunction due to noise.

#### 3.3.1 Terminals

##### (1) Contact input terminals

- Turning the signal across any terminal and common terminal "ON" (closing those terminals)/"OFF" (opening those terminals) provides the corresponding function as described below.
- The shaded terminal symbols indicate that their functions can be changed.

**Refer to: Chapter 8, 8.4 Selection of the Control Circuit Contact Input Terminal Functions**

| Symbol | Name                       | Description                                                                                                                                                                                                       |                                                               |
|--------|----------------------------|-------------------------------------------------------------------------------------------------------------------------------------------------------------------------------------------------------------------|---------------------------------------------------------------|
| STF    | Forward rotation start     | Turn on this signal to start forward rotation or turn it off to stop.                                                                                                                                             | Simultaneously turning on these signals gives a stop command. |
| STR    | Reverse rotation start     | Turn on this signal to start reverse rotation or turn it off to stop.                                                                                                                                             |                                                               |
| RES    | Reset                      | Turn on this signal (for more than 0.1s) to reset the protective circuit activated. Turn it off after the protective circuit is reset.                                                                            |                                                               |
| MRS    | Output stop                | Turn on this signal (for more than 0.1s) to stop the output and separate the motor electrically, causing it to coast. Turning it off with the start signal input will restart the motor at the starting speed.    |                                                               |
| RH     | High speed                 | Combine on/off of these signals as appropriate to select multiple speeds.<br><b>Refer to: Chapter 8, 8.3.2 Variable-speed operation using contact input signals</b>                                               |                                                               |
| RM     | Middle speed               |                                                                                                                                                                                                                   |                                                               |
| RL     | Low speed                  |                                                                                                                                                                                                                   |                                                               |
| SD     | Contact input common       | Common to the contact input terminals. (Not isolated from terminal 5.)                                                                                                                                            |                                                               |
| PC     | External transistor common | Common terminal used when the contact input terminal is connected to the transistor output (open collector output) of the external controller. This terminal can prevent a malfunction caused by a sneak current. |                                                               |

|             |                                                                                                                                                                                                                                                                                                                                                                                                                                                                                                                                                                                                                                                                                                                                                                                                    |
|-------------|----------------------------------------------------------------------------------------------------------------------------------------------------------------------------------------------------------------------------------------------------------------------------------------------------------------------------------------------------------------------------------------------------------------------------------------------------------------------------------------------------------------------------------------------------------------------------------------------------------------------------------------------------------------------------------------------------------------------------------------------------------------------------------------------------|
| <b>MEMO</b> | <ul style="list-style-type: none"> <li>● Ratings of the contact input terminals<br/>Input resistance: 4.7kΩ, open-time voltage: 24±3VDC, short circuit-time current: 4 to 6mADC</li> <li>● Use the terminal PC as a power supply terminal.<br/>Can be used as a power supply for a sensor or equivalent. The common terminal is the terminal SD (digital common).<br/>Power supply voltage range: 24±2VDC, max. permissible current: 100mA<br/>When the terminal is used as a power supply, it cannot be used as an external transistor common terminal to prevent a sneak current.</li> <li>● The response time of the contact input terminal is 20ms±15ms. (When the stall prevention function is activated, response may be slower.)</li> <li>● Terminals SD and 5 are not isolated.</li> </ul> |
|-------------|----------------------------------------------------------------------------------------------------------------------------------------------------------------------------------------------------------------------------------------------------------------------------------------------------------------------------------------------------------------------------------------------------------------------------------------------------------------------------------------------------------------------------------------------------------------------------------------------------------------------------------------------------------------------------------------------------------------------------------------------------------------------------------------------------|

|               |                                                                                                                                                                                                                                                                                                                                                                                                                                                                                                                                                                                                                                                                                                                                                                                                  |
|---------------|--------------------------------------------------------------------------------------------------------------------------------------------------------------------------------------------------------------------------------------------------------------------------------------------------------------------------------------------------------------------------------------------------------------------------------------------------------------------------------------------------------------------------------------------------------------------------------------------------------------------------------------------------------------------------------------------------------------------------------------------------------------------------------------------------|
| <b>NOTICE</b> | <ul style="list-style-type: none"> <li>● When a transistor is used to input the signal of the contact input terminal, make sure that the electrical characteristics of the transistor used satisfy the following: <ul style="list-style-type: none"> <li>I<sub>C</sub>: Collector current, 10mA or more</li> <li>V<sub>CEX</sub>: Open-time collector-emitter permissible voltage, 30V or more</li> <li>V<sub>CE(sat)</sub>: Conduction-time collector-emitter saturation voltage, 3V or less</li> <li>I<sub>CEX</sub>: Collector shutoff current (leakage current), 100uA or less</li> </ul> </li> <li>● When a relay contact is used to input the signal of the contact input terminal, use two faint signal contacts in parallel or use a twin contact to prevent a contact fault.</li> </ul> |
|---------------|--------------------------------------------------------------------------------------------------------------------------------------------------------------------------------------------------------------------------------------------------------------------------------------------------------------------------------------------------------------------------------------------------------------------------------------------------------------------------------------------------------------------------------------------------------------------------------------------------------------------------------------------------------------------------------------------------------------------------------------------------------------------------------------------------|

## (2) Speed command input terminals

- Terminals used to vary the motor speed with analog signals.
- The parameter function allows you to choose the analog speed command specifications.

**Refer to: Chapter 8, 8.3.1 Selection of the analog speed command specifications**

| Symbol | Name            | Rating                                                      | Description                                                                                                                        |
|--------|-----------------|-------------------------------------------------------------|------------------------------------------------------------------------------------------------------------------------------------|
| 2      | Voltage input   | Input resistance: 10±1kΩ<br>Max. permissible voltage: 20VDC | You can perform operation at the speed proportional to a 0 to 10VDC (or 0 to 5VDC) voltage signal.                                 |
| 4      |                 |                                                             | Keep this terminal open.                                                                                                           |
| 5      | Analog common   | —                                                           | Common to the speed command input terminals. Do not earth.                                                                         |
| 10     | Power supply 5V | 5V±0.2VDC<br>Permissible load current: 10mA                 | Can be used as a power supply for the analog input signal, e.g. speed setting potentiometer.<br>The common terminal is terminal 5. |

## (3) Transistor output terminals

- When the function of any terminal is activated, the internal transistor (open collector output) connected across that terminal and common terminal turns ON (conducts).
- You can set the parameter function to change the function of each terminal.

**Refer to: Chapter 8, 8.7.2 Selection of the control circuit output terminal functions**

**Chapter 8, 8.7.3 Detection of running speed**

| Symbol | Name                     | Description                                                                                                                                               |
|--------|--------------------------|-----------------------------------------------------------------------------------------------------------------------------------------------------------|
| RUN    | Running                  | ON (conducts) while the drive unit is outputting a speed command to the motor. OFF (does not conduct) during stop or coasting.                            |
| FU     | Speed detection          | Turns ON (conducts) when the speed output by the drive unit reaches or exceeds the preset value. OFF (does not conduct) when the speed is less than that. |
| SE     | Transistor output common | Common to the transistor output terminals. Isolated from the terminals SD, 5.                                                                             |

|             |                                                                                                                                                                  |
|-------------|------------------------------------------------------------------------------------------------------------------------------------------------------------------|
| <b>MEMO</b> | <ul style="list-style-type: none"> <li>● Ratings of transistor output terminals<br/>Max. permissible voltage: 27VDC, max. permissible current: 0.1ADC</li> </ul> |
|-------------|------------------------------------------------------------------------------------------------------------------------------------------------------------------|

|               |                                                                                                                                                                     |
|---------------|---------------------------------------------------------------------------------------------------------------------------------------------------------------------|
| <b>NOTICE</b> | <ul style="list-style-type: none"> <li>● When driving a coil load, connect a diode.<br/><b>Refer to: 3.3.5 Wiring of the transistor output terminals</b></li> </ul> |
|---------------|---------------------------------------------------------------------------------------------------------------------------------------------------------------------|

#### (4) Contact output terminals

- When the protective function is activated, the relay contact connected to the terminal opens/closes.

**Refer to: Chapter 6, 6.1.1 Protective function activated**

| Symbol  | Contact Capacity             | Description                                                                                                                          |
|---------|------------------------------|--------------------------------------------------------------------------------------------------------------------------------------|
| A, B, C | 200VAC 0.3A or<br>30VDC 0.3A | Normal : Terminals B-C closed<br>(Terminals A-C open)<br>Protective function activated: Terminals B-C open<br>(Terminals A-C closed) |

|             |                                                                                                                                                                                                                                                                                                                                                                                                                                                              |
|-------------|--------------------------------------------------------------------------------------------------------------------------------------------------------------------------------------------------------------------------------------------------------------------------------------------------------------------------------------------------------------------------------------------------------------------------------------------------------------|
| <b>MEMO</b> | <ul style="list-style-type: none"> <li>● The response time of the contact output terminals is less than 100ms. (After drive unit output shutoff)</li> <li>● When the drive unit is powered off, the contact output is placed in a normal status. Therefore, the contact output signal is not held when power is switched off after the protective function has been activated. When the signal must be held, provide an external holding circuit.</li> </ul> |
|-------------|--------------------------------------------------------------------------------------------------------------------------------------------------------------------------------------------------------------------------------------------------------------------------------------------------------------------------------------------------------------------------------------------------------------------------------------------------------------|

#### (5) Instrument connection terminals

- Used to display the motor speed externally.
- You can use the parameter function to choose the item other than the motor speed.

**Refer to: Chapter 8, 8.7.5 Selection of the instrument connection terminal functions**

| Symbol | Name             | Description                                                                                                                                                                                                                                                                                                       |
|--------|------------------|-------------------------------------------------------------------------------------------------------------------------------------------------------------------------------------------------------------------------------------------------------------------------------------------------------------------|
| FM     | Meter connection | The output voltage has an 8VDC pulse waveform.<br>The output varies in proportion to the motor speed and the average voltage is preset to approx. 4.7V at the rated speed and 1440 pulses/s.<br>As a meter, use a 1mA moving-coil type DC ammeter or digital counter.<br>As the common terminal, use terminal SD. |

|             |                                                                                                                                     |
|-------------|-------------------------------------------------------------------------------------------------------------------------------------|
| <b>MEMO</b> | <ul style="list-style-type: none"> <li>● The output signal from the FM terminal is updated at intervals of several 10ms.</li> </ul> |
|-------------|-------------------------------------------------------------------------------------------------------------------------------------|

### 3.3.2 Terminal layout and connection specifications

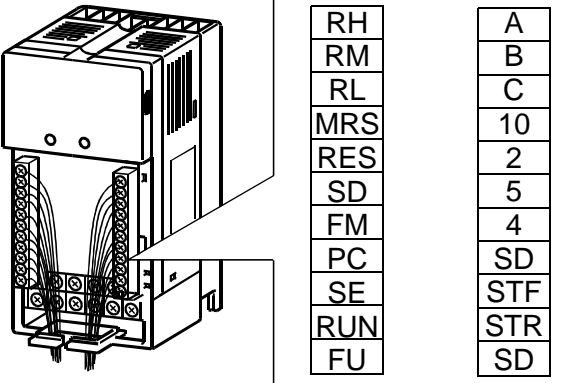
|                                                                                    |                                                                                                                                                                                                                                                                                                                                                                                                                                           |    |   |    |   |    |   |     |    |     |   |    |   |    |   |    |    |    |     |     |     |    |    |
|------------------------------------------------------------------------------------|-------------------------------------------------------------------------------------------------------------------------------------------------------------------------------------------------------------------------------------------------------------------------------------------------------------------------------------------------------------------------------------------------------------------------------------------|----|---|----|---|----|---|-----|----|-----|---|----|---|----|---|----|----|----|-----|-----|-----|----|----|
| Layout                                                                             |                                                                                                                                                                                                                                                                                                                                                                                                                                           |    |   |    |   |    |   |     |    |     |   |    |   |    |   |    |    |    |     |     |     |    |    |
| Terminal layout of control circuit                                                 |                                                                                                                                                                                                                                                                                                                                                                                                                                           |    |   |    |   |    |   |     |    |     |   |    |   |    |   |    |    |    |     |     |     |    |    |
|  | <table border="1" style="margin-left: auto; margin-right: auto;"> <tr><td>RH</td><td>A</td></tr> <tr><td>RM</td><td>B</td></tr> <tr><td>RL</td><td>C</td></tr> <tr><td>MRS</td><td>10</td></tr> <tr><td>RES</td><td>2</td></tr> <tr><td>SD</td><td>5</td></tr> <tr><td>FM</td><td>4</td></tr> <tr><td>PC</td><td>SD</td></tr> <tr><td>SE</td><td>STF</td></tr> <tr><td>RUN</td><td>STR</td></tr> <tr><td>FU</td><td>SD</td></tr> </table> | RH | A | RM | B | RL | C | MRS | 10 | RES | 2 | SD | 5 | FM | 4 | PC | SD | SE | STF | RUN | STR | FU | SD |
| RH                                                                                 | A                                                                                                                                                                                                                                                                                                                                                                                                                                         |    |   |    |   |    |   |     |    |     |   |    |   |    |   |    |    |    |     |     |     |    |    |
| RM                                                                                 | B                                                                                                                                                                                                                                                                                                                                                                                                                                         |    |   |    |   |    |   |     |    |     |   |    |   |    |   |    |    |    |     |     |     |    |    |
| RL                                                                                 | C                                                                                                                                                                                                                                                                                                                                                                                                                                         |    |   |    |   |    |   |     |    |     |   |    |   |    |   |    |    |    |     |     |     |    |    |
| MRS                                                                                | 10                                                                                                                                                                                                                                                                                                                                                                                                                                        |    |   |    |   |    |   |     |    |     |   |    |   |    |   |    |    |    |     |     |     |    |    |
| RES                                                                                | 2                                                                                                                                                                                                                                                                                                                                                                                                                                         |    |   |    |   |    |   |     |    |     |   |    |   |    |   |    |    |    |     |     |     |    |    |
| SD                                                                                 | 5                                                                                                                                                                                                                                                                                                                                                                                                                                         |    |   |    |   |    |   |     |    |     |   |    |   |    |   |    |    |    |     |     |     |    |    |
| FM                                                                                 | 4                                                                                                                                                                                                                                                                                                                                                                                                                                         |    |   |    |   |    |   |     |    |     |   |    |   |    |   |    |    |    |     |     |     |    |    |
| PC                                                                                 | SD                                                                                                                                                                                                                                                                                                                                                                                                                                        |    |   |    |   |    |   |     |    |     |   |    |   |    |   |    |    |    |     |     |     |    |    |
| SE                                                                                 | STF                                                                                                                                                                                                                                                                                                                                                                                                                                       |    |   |    |   |    |   |     |    |     |   |    |   |    |   |    |    |    |     |     |     |    |    |
| RUN                                                                                | STR                                                                                                                                                                                                                                                                                                                                                                                                                                       |    |   |    |   |    |   |     |    |     |   |    |   |    |   |    |    |    |     |     |     |    |    |
| FU                                                                                 | SD                                                                                                                                                                                                                                                                                                                                                                                                                                        |    |   |    |   |    |   |     |    |     |   |    |   |    |   |    |    |    |     |     |     |    |    |
| Screw size                                                                         | Tightening torque                                                                                                                                                                                                                                                                                                                                                                                                                         |    |   |    |   |    |   |     |    |     |   |    |   |    |   |    |    |    |     |     |     |    |    |
| M2.5                                                                               | 0.25N•m to 0.49 N•m                                                                                                                                                                                                                                                                                                                                                                                                                       |    |   |    |   |    |   |     |    |     |   |    |   |    |   |    |    |    |     |     |     |    |    |

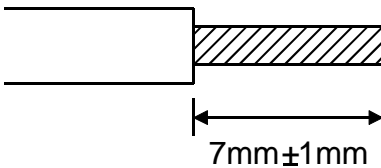
|                                                                                                                                                                                                                                                                                                                                                                                                                                                                                                                                                                                                                                                                                                                                                                                                                                                                                                                                                                                                                                                                                                                                                                                                                                   |
|-----------------------------------------------------------------------------------------------------------------------------------------------------------------------------------------------------------------------------------------------------------------------------------------------------------------------------------------------------------------------------------------------------------------------------------------------------------------------------------------------------------------------------------------------------------------------------------------------------------------------------------------------------------------------------------------------------------------------------------------------------------------------------------------------------------------------------------------------------------------------------------------------------------------------------------------------------------------------------------------------------------------------------------------------------------------------------------------------------------------------------------------------------------------------------------------------------------------------------------|
| <p>Wiring method</p> <p>1) For wiring the control circuit, use cables after stripping their sheaths.<br/>Refer to the gauge printed on the drive unit and strip the sheaths to the following dimensions. If the sheath is stripped too much, its cable may be shorted with the adjoining cable. If the sheath is stripped too little, the cable may come off.</p> <div style="text-align: center;">  </div> <p>2) When using bar terminals and solid wires for wiring, their diameters should be 0.9mm maximum. If they are larger, the threads may be damaged during tightening.</p> <p>3) Loosen the terminal screw and insert the cable into the terminal.</p> <p>4) Tighten the screw to the specified torque.<br/>Undertightening can cause cable disconnection or misoperation. Overtightening can cause damage to the screw or unit, leading to short circuit or misoperation.<br/>Tightening torque: 0.25N•m to 0.49N•m<br/>* Use a screwdriver No. 0 to tighten.</p> <p>Note: When routing the stripped cables, twist them so that they do not become loose.<br/>In addition, do not solder it. Soldering can cause poor contact.</p> |
|-----------------------------------------------------------------------------------------------------------------------------------------------------------------------------------------------------------------------------------------------------------------------------------------------------------------------------------------------------------------------------------------------------------------------------------------------------------------------------------------------------------------------------------------------------------------------------------------------------------------------------------------------------------------------------------------------------------------------------------------------------------------------------------------------------------------------------------------------------------------------------------------------------------------------------------------------------------------------------------------------------------------------------------------------------------------------------------------------------------------------------------------------------------------------------------------------------------------------------------|

|               |                                                                                                                                                                                                                                                                                                                                                   |
|---------------|---------------------------------------------------------------------------------------------------------------------------------------------------------------------------------------------------------------------------------------------------------------------------------------------------------------------------------------------------|
| <b>NOTICE</b> | <ul style="list-style-type: none"> <li>● When using a bar terminal or a solid wire for wiring, use one of 0.9mm or less diameter. Using one of larger diameter may damage the threads during tightening.</li> <li>● Connect stripped cable so that its core does not become loose. Not doing so can cause shorting of adjacent cables.</li> </ul> |
|---------------|---------------------------------------------------------------------------------------------------------------------------------------------------------------------------------------------------------------------------------------------------------------------------------------------------------------------------------------------------|

### 3.3.3 Wiring of the contact input terminals

Use shielded or twisted shielded cables for wiring. Connect one shield sheath to the common terminal. Leave the other shield sheath open.

● When using contact signals

The following shows the wiring of the terminals STF, STR. The same wiring also applies to the other terminals.

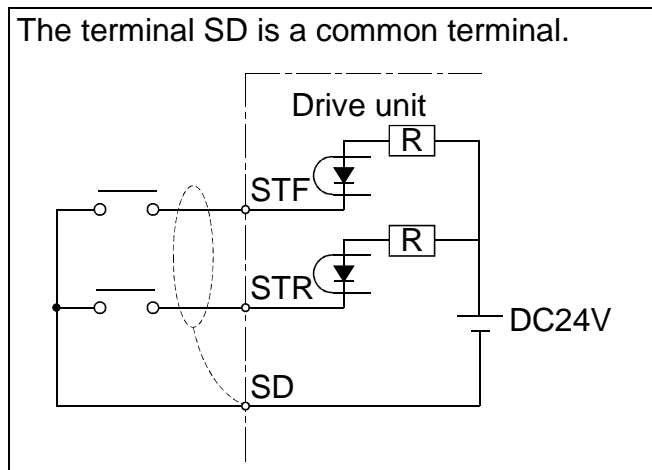

● When using non-contact switches

When using transistor outputs having an external power supply, such as a PLC, to input signals, perform the following wiring to prevent a malfunction caused by a sneak current from the external power supply.

The following shows the wiring of the terminals STF, STR. The same wiring also applies to the other terminals.

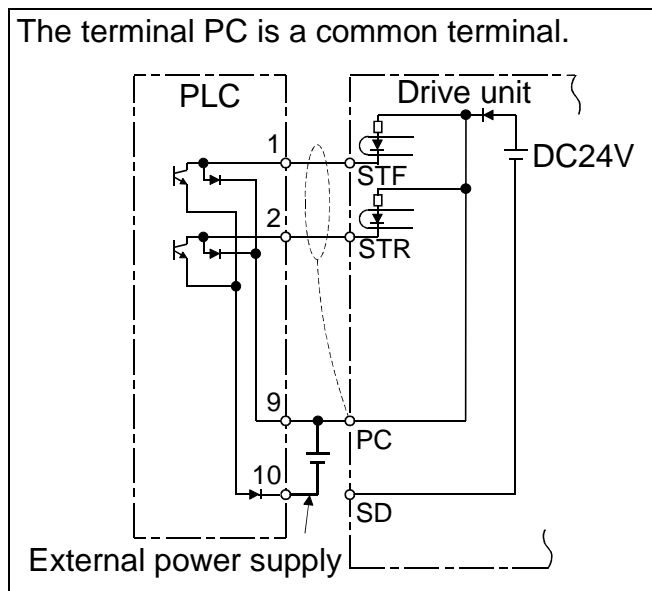

**NOTICE**

- Do not apply voltages to the contact input terminals.
- Do not short the terminals PC and SD. Doing so will damage the unit.
- When the terminal PC is used as a power supply terminal, the wiring length should be within 30m.

### 3.3.4 Wiring of the speed command input terminals

Use shielded or twisted shielded cables for wiring. Connect one shield sheath to the terminal 5. Leave the other shield sheath open. The following diagram shows the wiring of the terminal 2. The same wiring also applies to the other terminals.

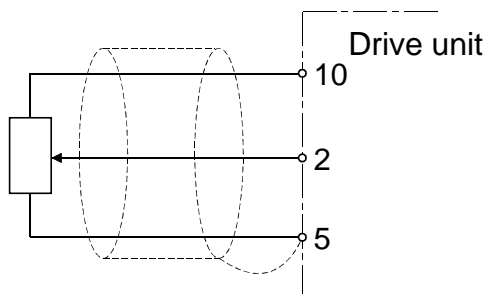

### 3.3.5 Wiring of the transistor output terminals

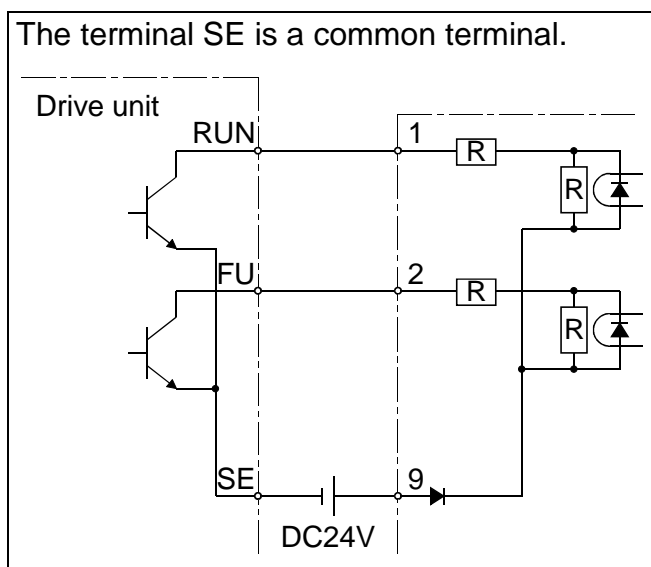

When driving a coil load such as a relay coil, always connect the following diode. Connect the diode with correct polarity. Opposite polarity will cause the drive unit to fail.

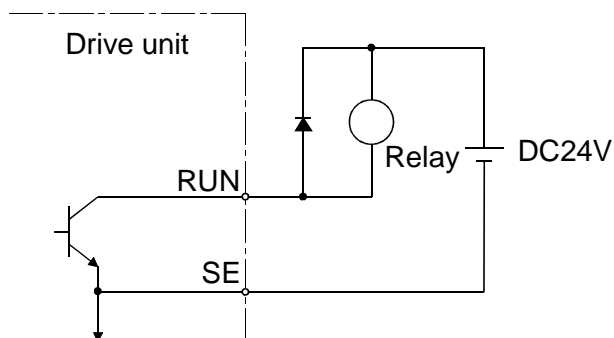

**NOTICE** ● Terminal SE is isolated from terminals SD and 5. Do not connect them each other.



### 3.3.6 Wiring of the contact output terminals

The following wiring example assumes that when the protective circuit is activated, the magnetic contactor (MC) on the power supply side is opened to switch off the main circuit power.

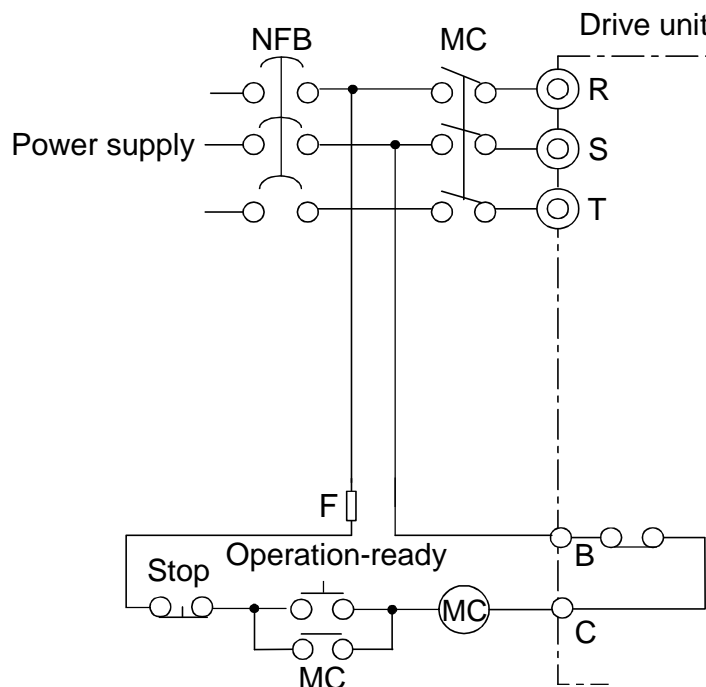

### 3.3.7 Wiring of the instrument connection terminals

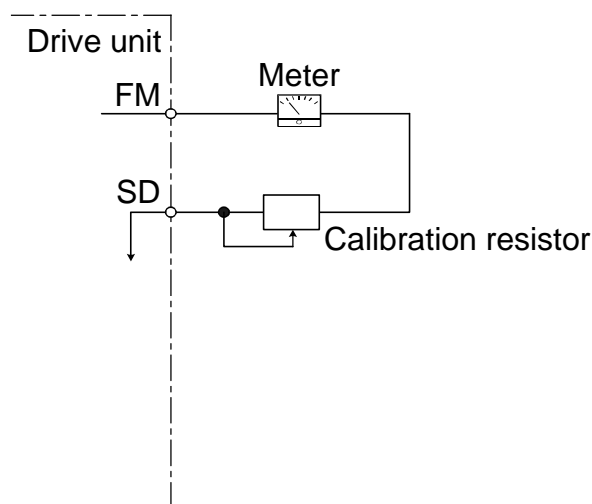

#### MEMO

● The calibration resistor is not needed when the parameter unit is used to make calibration.

Refer to: Pr. 900 [Section 8.7.5]

## 3.4 Wiring of the PU Connector

### 3.4.1 Pin layout

As seen from the drive unit (receptacle side) front

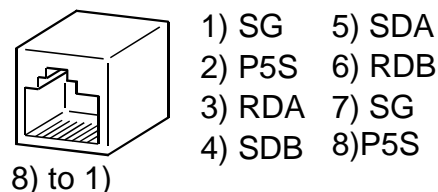

**NOTICE** ● Pins No. 2 and 8 (P5S) provide power to the operation panel. Do not use them when making RS-485 communication.

### 3.4.2 Using the cable to connect the parameter unit

Use the optional "FR-CB2 parameter unit connection cable" or commercially available connector and cable for wiring.

|           |                                                                                                                                                                                               |
|-----------|-----------------------------------------------------------------------------------------------------------------------------------------------------------------------------------------------|
| Connector | RJ45 connector<br>Example: 5-554720-3, Tyco Electronics Corporation                                                                                                                           |
| Cable     | Cable conforming to EIA568 (such as 10BASE-T cable)<br>Example: SGLPEV 0.5mm × 4P (Twiced pair cable, 4 pairs), Mitsubishi Cable Industries, Ltd.<br>(Do not use the No. 2 and 8 pins (P5S).) |

**NOTICE** ● The maximum wiring length is 20m.

3

### 3.4.3 System configuration examples for communication operations

1) For RS-485 communication operation

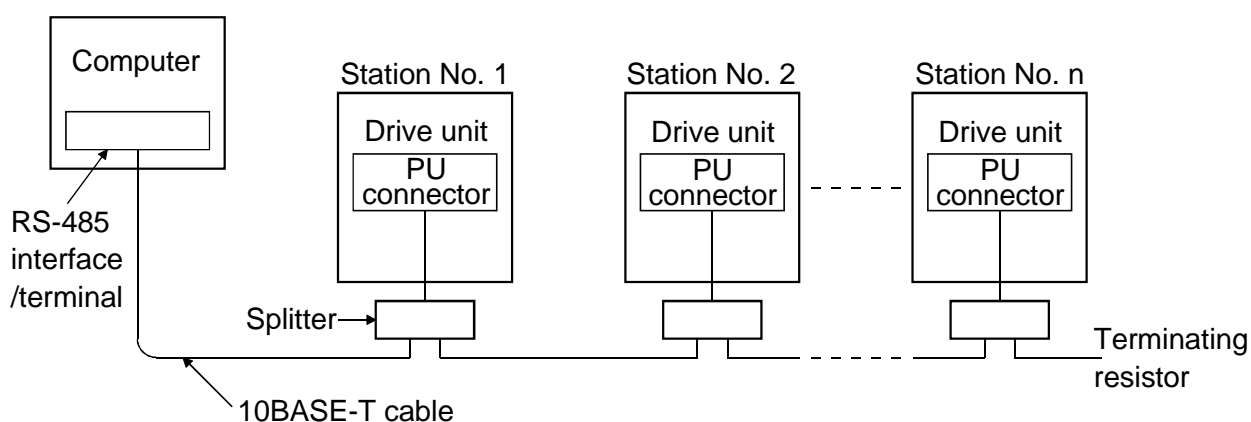

● Parts used (Use commercially available parts for wiring)

|           |                                                                                                                                                                                                |
|-----------|------------------------------------------------------------------------------------------------------------------------------------------------------------------------------------------------|
| Connector | RJ45 connector<br>Example: 5-554720-3, Tyco Electronics Corporation                                                                                                                            |
| Cable     | Cable conforming to EIA568 (such as 10BASE-T cable)<br>Example: SGLPEV 0.5mm × 4P (Twisted pair cable, 4 pairs), Mitsubishi Cable Industries, Ltd.<br>(Do not use the No. 2 and 8 pins (P5S).) |

2) For RS-232C communication operation

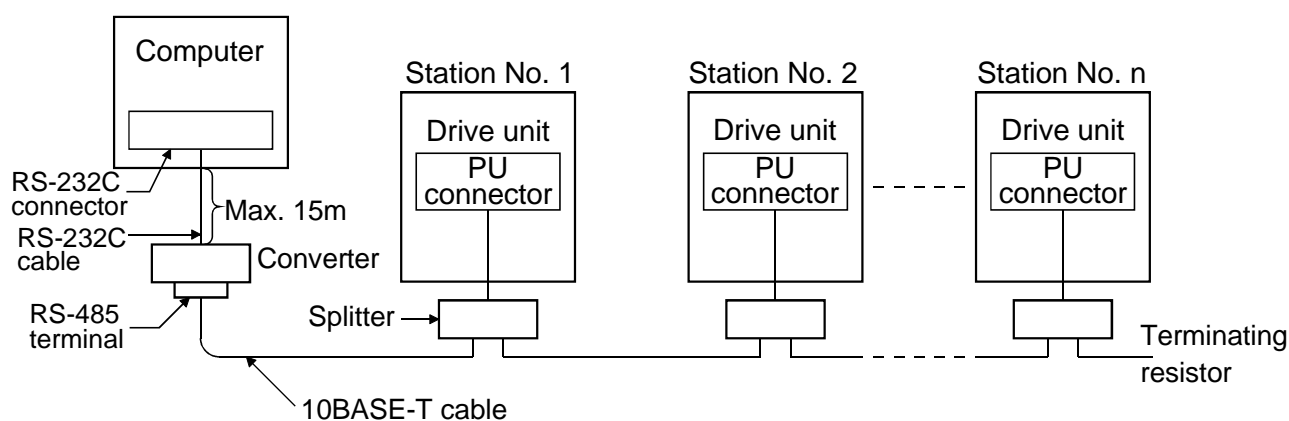

● Parts used (Use commercially available parts for wiring)

|                                  |                                                                                                                                                                                                |
|----------------------------------|------------------------------------------------------------------------------------------------------------------------------------------------------------------------------------------------|
| Connector                        | RJ45 connector<br>Example: 5-554720-3, Tyco Electronics Corporation                                                                                                                            |
| Cable                            | Cable conforming to EIA568 (such as 10BASE-T cable)<br>Example: SGLPEV 0.5mm × 4P (Twisted pair cable, 4 pairs), Mitsubishi Cable Industries, Ltd.<br>(Do not use the No. 2 and 8 pins (P5S).) |
| Commercially available converter | Examples Model: FA-T-RS40 converter<br>Mitsubishi Electric Engineering Co., Ltd.                                                                                                               |

|               |                                                                                                                                                                                         |
|---------------|-----------------------------------------------------------------------------------------------------------------------------------------------------------------------------------------|
| <b>NOTICE</b> | ● Do not connect the PU connector to the computer's LAN board, FAX modem socket or telephone modular connector. Doing so may damage the drive unit due to electrical incompatibilities. |
|---------------|-----------------------------------------------------------------------------------------------------------------------------------------------------------------------------------------|

### 3.4.4 Wiring methods for communication operation

#### 1) Wiring of one computer and one drive unit for RS-485

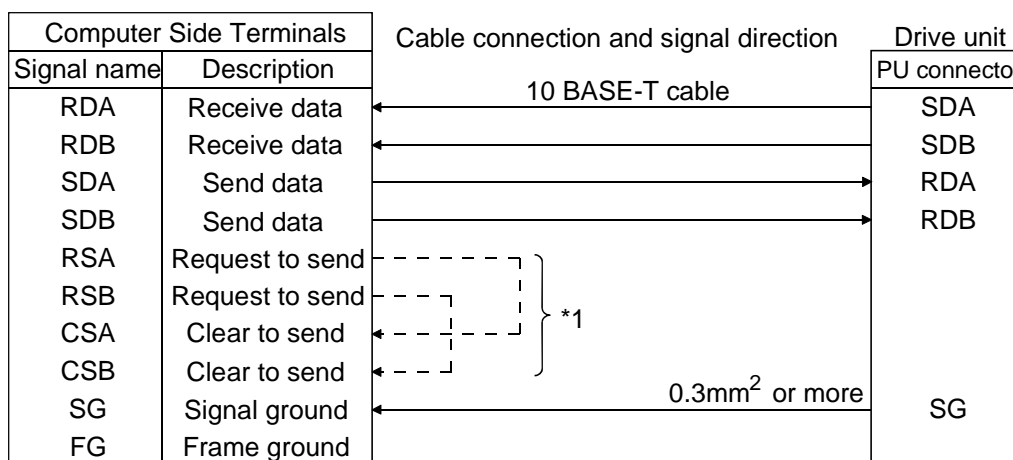

#### 2) Wiring of one computer and "n" drive units for RS-485

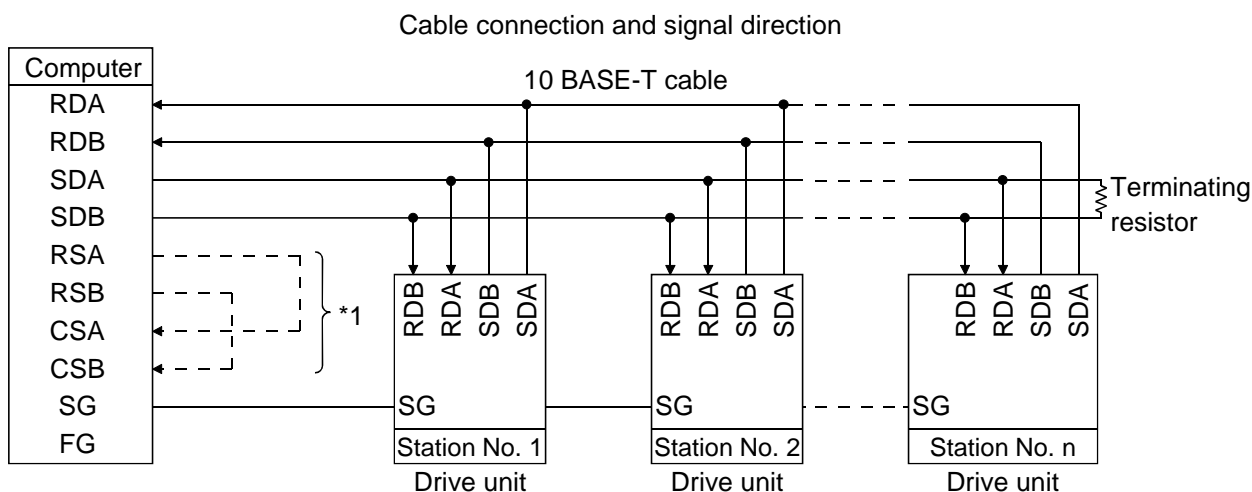

|               |                                                                                                                                                                                                                                                                                                                                                                                                                                                                                                                                                                                                                                                                  |
|---------------|------------------------------------------------------------------------------------------------------------------------------------------------------------------------------------------------------------------------------------------------------------------------------------------------------------------------------------------------------------------------------------------------------------------------------------------------------------------------------------------------------------------------------------------------------------------------------------------------------------------------------------------------------------------|
| <b>NOTICE</b> | <ul style="list-style-type: none"> <li>● Communication may be affected by reflection depending on the transmission speed and/or transmission distance. Connect a Terminating resistor if reflection interferes with communication. For connection using the PU connector, use a splitter since the termination resistor cannot be fitted. Connect the Terminating resistor to only the remotest drive unit from the computer. (Terminating resistor: 100Ω)</li> <li>● Connect the terminals marked *1 in accordance with the instruction manual of the computer used. Fully check the terminal numbers of the computer as they differ between models.</li> </ul> |
|---------------|------------------------------------------------------------------------------------------------------------------------------------------------------------------------------------------------------------------------------------------------------------------------------------------------------------------------------------------------------------------------------------------------------------------------------------------------------------------------------------------------------------------------------------------------------------------------------------------------------------------------------------------------------------------|

## 4. HOW TO USE THE FR-PU04 PARAMETER UNIT

For the way to use the FR-PU04 parameter unit, refer to the instruction manual of the FR-PU04 parameter unit.

|             |                                                                                                                                                                                                                                                                                                                                                                                                                                                                                                                                                                                                                                                                                                                                                                                                                                                                                                                                                                                                                                                                                                                                                                                                                                                                                                                                                                                |
|-------------|--------------------------------------------------------------------------------------------------------------------------------------------------------------------------------------------------------------------------------------------------------------------------------------------------------------------------------------------------------------------------------------------------------------------------------------------------------------------------------------------------------------------------------------------------------------------------------------------------------------------------------------------------------------------------------------------------------------------------------------------------------------------------------------------------------------------------------------------------------------------------------------------------------------------------------------------------------------------------------------------------------------------------------------------------------------------------------------------------------------------------------------------------------------------------------------------------------------------------------------------------------------------------------------------------------------------------------------------------------------------------------|
| <b>MEMO</b> | <ul style="list-style-type: none"> <li>● When the FR-PU04 parameter unit (option) is used, some of the FR-PU04 functions are unavailable.             <ol style="list-style-type: none"> <li>(1) Data may be displayed in Japanese only. It cannot be changed to any other language.</li> <li>(2) The parameter names (katakana characters) do not appear. (Except Pr. 900, Pr.902, Pr.903)</li> <li>(3) The parameter setting ranges do not appear.</li> <li>(4) The function-by-function parameter setting feature is not available.</li> <li>(5) Help function                 <ul style="list-style-type: none"> <li>● The parameter list does not appear.</li> <li>● The parameter change list does not appear.</li> <li>● The troubleshooting function is unavailable. "The remedy screen for "デンリュウガオオキイ" appears but the corresponding parameter function does not exist.</li> <li>● The terminal assignment function is not displayed.</li> </ul> </li> <li>(6) The PU level meter cannot be used.</li> <li>(7) Pr. 79 cannot be set.</li> </ol> </li> <li>● Copy mode             <p>Copying is not allowed between drive units of different capacities. If you have made such copying accidentally, perform all clear of the copy destination drive unit.</p> <p>In addition, copying is not allowed to drive units other than the MD-CX522 series.</p> </li> </ul> |
|-------------|--------------------------------------------------------------------------------------------------------------------------------------------------------------------------------------------------------------------------------------------------------------------------------------------------------------------------------------------------------------------------------------------------------------------------------------------------------------------------------------------------------------------------------------------------------------------------------------------------------------------------------------------------------------------------------------------------------------------------------------------------------------------------------------------------------------------------------------------------------------------------------------------------------------------------------------------------------------------------------------------------------------------------------------------------------------------------------------------------------------------------------------------------------------------------------------------------------------------------------------------------------------------------------------------------------------------------------------------------------------------------------|

## 5. OPERATION

### 5.1 Power On

#### CAUTION

- If the machine should become out of control, perform test operation after ensuring safety.
- Start operation after performing test operation under light load at low speed to ensure that operation is performed safely.
- Check that the machine has no damage.
- Securely set the parameter values to match the operating machine system environment.

Switch power on after making sure that the unit has been installed and wired properly and that the start signal is OFF.  
The POWER lamp is lit.

|               |                                                                                                                                                                                                                                                                                                                                                                                                                                                                         |
|---------------|-------------------------------------------------------------------------------------------------------------------------------------------------------------------------------------------------------------------------------------------------------------------------------------------------------------------------------------------------------------------------------------------------------------------------------------------------------------------------|
| <b>NOTICE</b> | <ul style="list-style-type: none"> <li>● If the POWER lamp is not lit, check the following:             <ul style="list-style-type: none"> <li>• The jumper across the DC reactor connection terminals P/+-P1 is fitted properly.</li> </ul> </li> <li>● If the POWER lamp is lit but the parameter unit LED does not appear, check the following:             <ul style="list-style-type: none"> <li>• The terminals PC and SD are not shorted.</li> </ul> </li> </ul> |
|---------------|-------------------------------------------------------------------------------------------------------------------------------------------------------------------------------------------------------------------------------------------------------------------------------------------------------------------------------------------------------------------------------------------------------------------------------------------------------------------------|

### 5.2 Setting of Operation Mode

You can choose the PU operation mode or external operation mode.  
In the PU operation mode, enter a speed/operation command from the parameter unit.  
In the external operation mode, enter an external analog or contact signal as a speed/operation command.

|             |                                                                                                                                                                                                                                                                                                                                        |
|-------------|----------------------------------------------------------------------------------------------------------------------------------------------------------------------------------------------------------------------------------------------------------------------------------------------------------------------------------------|
| <b>MEMO</b> | <ul style="list-style-type: none"> <li>● At power-on, the drive unit is placed in the external operation mode. To switch to the PU operation mode, press the <b>PU</b> key of the parameter unit.<br/>To return to the external operation mode, press the <b>EXT</b> key or switch power off once. (You cannot set Pr. 79.)</li> </ul> |
|-------------|----------------------------------------------------------------------------------------------------------------------------------------------------------------------------------------------------------------------------------------------------------------------------------------------------------------------------------------|

## 5.3 Starting operation

The drive unit detects the magnetic pole of the motor at every start. The magnetic pole detection time is approx. 0.1s ( $85\text{ms} \pm 15\text{ms}$ ) after the start signal and speed signal are input. During this period, the motor remains stopped and starts running after magnetic pole detection is finished.

- When inputting the speed command from the parameter unit or as a contact signal

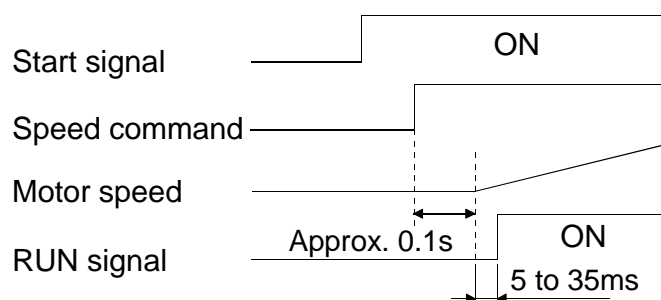

- When inputting the speed command as an analog signal

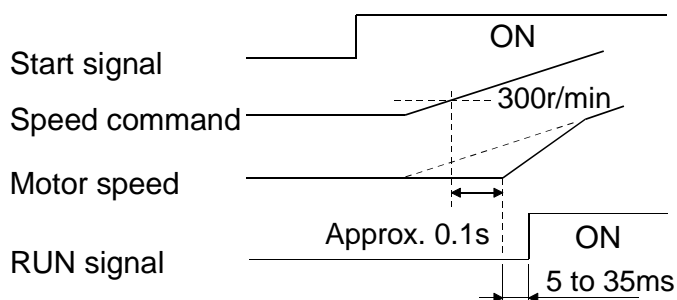

|               |                                                                                                                                                                                                                                                                                                                                                                                                                                                                                                                                                                                                                                                                   |
|---------------|-------------------------------------------------------------------------------------------------------------------------------------------------------------------------------------------------------------------------------------------------------------------------------------------------------------------------------------------------------------------------------------------------------------------------------------------------------------------------------------------------------------------------------------------------------------------------------------------------------------------------------------------------------------------|
| <b>MEMO</b>   | <ul style="list-style-type: none"> <li>● When the start signal is entered after the input of the speed command, the motor starts running approx. 0.1s after the input of the start signal.</li> <li>● When the analog signal is used to give the speed command, the motor starts running approx. 0.1s after the speed command has reached the value equivalent to 300r/min.</li> <li>● Turning on the reverse rotation (forward rotation) signal during forward rotation (reverse rotation) operation decelerates the motor to a stop, keeps it stopped for about 2s, and then starts it running in the reverse rotation (forward rotation) direction.</li> </ul> |
| <b>NOTICE</b> | <ul style="list-style-type: none"> <li>● When restarting the motor after decelerating it to a stop, start the motor after ensuring that it has stopped. If you start the motor that has not yet come to a complete stop, sufficient starting torque may not be provided.</li> <li>● Do not switch the AC input power off while the motor is running at high speed. Doing so may activate the undervoltage protective circuit instantaneously under the influence of a motor-generated voltage.</li> </ul> <p style="text-align: center;"><b>Refer to: Chapter 6, 6.1.1 Protective function activated</b></p>                                                      |

## 6. TROUBLESHOOTING

This chapter describes how to remedy a fault which occurred in your drive unit or motor and the maintenance and inspection of the drive unit.

|               |                                                                                                                                                                                                                                                       |
|---------------|-------------------------------------------------------------------------------------------------------------------------------------------------------------------------------------------------------------------------------------------------------|
| <b>NOTICE</b> | <ul style="list-style-type: none"> <li>● If you have found any fault, immediately perform inspection and take action to remove its cause. If you cannot identify the cause and resolve the malfunction, contact your sales representative.</li> </ul> |
|---------------|-------------------------------------------------------------------------------------------------------------------------------------------------------------------------------------------------------------------------------------------------------|

### **WARNING**

- **At occurrence of an alarm, turn off the operation signal before resetting the alarm. Resetting the alarm with the operation signal on will restart the motor suddenly. It can cause injury.**
- **At occurrence of an alarm, immediately turn off the operation signal. Not doing so may reset the alarm due to power OFF-ON, e.g. instantaneous power failure, restarting the motor suddenly. It can cause injury.**

## 6.1 Message Appearing on the Parameter Unit

### 6.1.1 Protective function activated

When the protective function is activated, any of the following messages may appear on the parameter unit. At this time, the ALARM lamp is lit, the drive unit output is shut off, and the motor, if running, coasts.

|             |                                                                                                                                                                                                                                                                |
|-------------|----------------------------------------------------------------------------------------------------------------------------------------------------------------------------------------------------------------------------------------------------------------|
| <b>MEMO</b> | <ul style="list-style-type: none"> <li>● That the protective function has been activated can be exported from the control circuit output terminal.<br/><b>Refer to: Chapter 8, 8.7.2 Selection of the control circuit output terminal functions</b></li> </ul> |
|-------------|----------------------------------------------------------------------------------------------------------------------------------------------------------------------------------------------------------------------------------------------------------------|

When the protective function is activated, perform inspection and take action in accordance with Table 6-1 to remove its cause.

- To restart, reset the drive unit in any of the following methods.
  - Switch power off once, and when the LED has gone off, switch power on again.
  - Short the terminals RES-SD for more than 0.1s.
  - Press the STOP/RESET key of the parameter unit.



Table 6-1

| Parameter Unit Display | Protective Function Name Detection Level                                                    | Possible Cause (●) and Corrective Action (●)                                                                                                                                                                                                                                                                                                                                                                                                                                                                                                                                                                 |
|------------------------|---------------------------------------------------------------------------------------------|--------------------------------------------------------------------------------------------------------------------------------------------------------------------------------------------------------------------------------------------------------------------------------------------------------------------------------------------------------------------------------------------------------------------------------------------------------------------------------------------------------------------------------------------------------------------------------------------------------------|
| カソクジ<br>カデンリュウ         | <b>Acceleration-time overcurrent</b><br>Output current is more than 200% of motor rating.   | <ul style="list-style-type: none"> <li>● The acceleration torque is beyond the drive unit capability. <ul style="list-style-type: none"> <li>● Increase the acceleration time.</li> </ul> </li> <li>● Outputs U, V and W are in a short circuit or ground fault. <ul style="list-style-type: none"> <li>● Check the motor winding resistance.</li> <li>● Check the connection cables for damage.</li> </ul> </li> <li>● The motor restarted during coasting. <ul style="list-style-type: none"> <li>● Restart it after a complete stop.</li> </ul> </li> </ul>                                               |
| テイソクジ<br>カデンリュウ        | <b>Constant speed-time overcurrent</b><br>Output current is more than 200% of motor rating. | <ul style="list-style-type: none"> <li>● Excessive load was applied instantaneously.</li> <li>● Outputs U, V and W resulted in a short circuit or ground fault during constant-speed operation. <ul style="list-style-type: none"> <li>● Check the motor winding resistance.</li> <li>● Check the connection cables for damage.</li> </ul> </li> </ul>                                                                                                                                                                                                                                                       |
| ゲンソクジ<br>カデンリュウ        | <b>Deceleration-time overcurrent</b><br>Output current is more than 200% of motor rating.   | <ul style="list-style-type: none"> <li>● The deceleration torque is beyond the drive unit capability. <ul style="list-style-type: none"> <li>● Increase the deceleration time.</li> </ul> </li> <li>● Outputs U, V and W resulted in a short circuit or ground fault during deceleration operation. <ul style="list-style-type: none"> <li>● Check the motor winding resistance.</li> <li>● Check the connection cables for damage.</li> </ul> </li> <li>● The mechanical brake of the motor operates too early. <ul style="list-style-type: none"> <li>● Delay the operation timing.</li> </ul> </li> </ul> |
| カソクジ<br>カデンアツ          | <b>Acceleration-time overvoltage</b><br>Main circuit DC voltage is more than 400V.          | <ul style="list-style-type: none"> <li>● Surge compounded with power during acceleration operation. <ul style="list-style-type: none"> <li>● Install a reactor.</li> <li>● Fit a surge suppressor or like to the surge source.</li> </ul> </li> <li>● The regenerative energy handling capability is insufficient. <ul style="list-style-type: none"> <li>● Fit the regenerative brake option.</li> </ul> </li> </ul>                                                                                                                                                                                        |
| テイソクジ<br>カデンアツ         | <b>Constant speed-time overvoltage</b><br>Main circuit DC voltage is more than 400V.        | <ul style="list-style-type: none"> <li>● Surge compounded with power during acceleration operation. <ul style="list-style-type: none"> <li>● Install a reactor.</li> <li>● Fit a surge suppressor or like to the surge source.</li> </ul> </li> <li>● Load increased suddenly, activating the stall prevention function.</li> <li>● The regenerative energy handling capability is insufficient. <ul style="list-style-type: none"> <li>● Fit the regenerative brake option.</li> </ul> </li> </ul>                                                                                                          |
| ゲンソクジ<br>カデンアツ         | <b>Deceleration-time overvoltage</b><br>Main circuit DC voltage is more than 400V.          | <ul style="list-style-type: none"> <li>● The deceleration torque is beyond the drive unit capability. <ul style="list-style-type: none"> <li>● Increase the deceleration time.</li> </ul> </li> <li>● The regenerative energy handling capability is insufficient. <ul style="list-style-type: none"> <li>● Fit the regenerative brake option.</li> </ul> </li> <li>● Surge compounded with power during deceleration operation or stop. <ul style="list-style-type: none"> <li>● Install a reactor.</li> <li>● Fit a surge suppressor or like to the surge source.</li> </ul> </li> </ul>                   |

Table 6-1 (Continued)

| Parameter<br>Unit Display | Protective<br>Function Name<br>Detection Level                                                       | Possible Cause (●) and<br>Corrective Action (•)                                                                                                                                                                                                                                                                                                                                                                                                                                                                                                                                                                                                                                                                                                                                                                                    |
|---------------------------|------------------------------------------------------------------------------------------------------|------------------------------------------------------------------------------------------------------------------------------------------------------------------------------------------------------------------------------------------------------------------------------------------------------------------------------------------------------------------------------------------------------------------------------------------------------------------------------------------------------------------------------------------------------------------------------------------------------------------------------------------------------------------------------------------------------------------------------------------------------------------------------------------------------------------------------------|
| トランジスタ<br>ホゴサーマル          | <b>Electronic<br/>overcurrent<br/>protection</b>                                                     | <ul style="list-style-type: none"> <li>● The motor and drive unit are operated under overload. <ul style="list-style-type: none"> <li>• Reduce the load.</li> <li>• Increase the capacities of the motor and drive unit.</li> </ul> </li> </ul>                                                                                                                                                                                                                                                                                                                                                                                                                                                                                                                                                                                    |
| デンシ<br>サーマル               |                                                                                                      |                                                                                                                                                                                                                                                                                                                                                                                                                                                                                                                                                                                                                                                                                                                                                                                                                                    |
| フック<br>デンアツ               | <b>Undervoltage</b><br>AC input power supply voltage is less than about 150V.                        | <ul style="list-style-type: none"> <li>● An instantaneous voltage drop in the AC input power supply from the starting of a large capacity equipment, for example.<br/><b>NOTICE</b> Do not switch the AC input power off while the motor is running at high speed. Doing so may activate the undervoltage protective circuit instantaneously under the influence of a motor-generated voltage.</li> <li>● The AC input power supply voltage is insufficient.<br/><b>MEMO</b> An alarm signal is not output if this protective circuit is activated with the AC input power insufficient. It is also not recorded in the alarm history. To export as an external signal the fact that this protective circuit has been activated, assign the UVT signal to the control circuit output terminal using Pr. 190 or Pr. 194.</li> </ul> |
| フィン<br>カネツ                | <b>Fin overheat</b><br>Heat sink temperature is higher than the permissible value of the components. | <ul style="list-style-type: none"> <li>● The ambient temperature exceeded the permissible temperature.</li> <li>● The cooling fan failed.<br/><b>MEMO</b> An alarm signal can be provided by making control circuit output terminal assignment.</li> </ul>                                                                                                                                                                                                                                                                                                                                                                                                                                                                                                                                                                         |
| PUヌケ<br>ハッセイ              | <b>PU disconnection</b><br>—                                                                         | <ul style="list-style-type: none"> <li>● A connection fault of the parameter unit occurred.<br/><b>Refer to: Pr. 75 [Section 8.2]</b></li> <li>● RS-485 communication was interrupted.</li> <li>● The number of communication retries exceeded the Pr. 121 setting.<br/><b>Refer to: Pr. 121 [Section 8.6]</b></li> </ul>                                                                                                                                                                                                                                                                                                                                                                                                                                                                                                          |
| ストール<br>ボウシ<br>ニヨリ<br>テイシ | <b>Stall stop</b><br>Refer to: Pr. 22<br>[Section 8.5.4]                                             | <ul style="list-style-type: none"> <li>● Motor overload activated the stall prevention function consecutively, stopping the motor. <ul style="list-style-type: none"> <li>• Reduce the load.</li> <li>• Increase the capacities of the motor and drive unit.</li> </ul> </li> </ul>                                                                                                                                                                                                                                                                                                                                                                                                                                                                                                                                                |
| エラー15                     | <b>Out-of-synchronism</b>                                                                            | <ul style="list-style-type: none"> <li>● The load is too heavy. <ul style="list-style-type: none"> <li>• Increase the acceleration time setting.</li> <li>• Reduce the load.</li> </ul> </li> <li>● The motor being driven is other than the specified. <ul style="list-style-type: none"> <li>• Use the specified motor.</li> </ul> </li> </ul>                                                                                                                                                                                                                                                                                                                                                                                                                                                                                   |

If any of the messages in Table 6-2 appears, the drive unit is assumed to have failed. If the same message reappears after an alarm reset, immediately replace the drive unit.

Table 6-2

| Parameter Unit Display | Protective Function Name    | Possible Cause (●) and Corrective Action (●)                                                                                                                                                                           |
|------------------------|-----------------------------|------------------------------------------------------------------------------------------------------------------------------------------------------------------------------------------------------------------------|
| CPUエラー                 | <b>CPU fault</b>            | ● The CPU malfunctioned or failed.                                                                                                                                                                                     |
| パラメータエラー               | <b>Storage device fault</b> | ● The storage device failed.                                                                                                                                                                                           |
| ブレーキカイロイジョウ            | <b>Brake circuit fault</b>  | ● The regenerative brake circuit failed. <ul style="list-style-type: none"> <li>● If E. BE reappears after a reset, immediately switch power off.</li> </ul> <b>Leaving power on will overheat the brake resistor.</b> |

### 6.1.2 Alarm function activated

If the alarm function is activated during motor operation, any of the displays in Table 6-3 is provided on the parameter unit.

If you ignore the alarm message and continue operation, the fault detection function is activated, leading to an operation stop. When you noticed that the alarm function had been activated, immediately remove its cause.

|             |                                                                                                                                                                                  |
|-------------|----------------------------------------------------------------------------------------------------------------------------------------------------------------------------------|
| <b>MEMO</b> | ● That the alarm function has been activated can be exported as an alarm signal.<br><b>Refer to: Chapter 8, 8.7.2 Selection of the control circuit output terminal functions</b> |
|-------------|----------------------------------------------------------------------------------------------------------------------------------------------------------------------------------|

Table 6-3

| Parameter Unit Display | Protective Function Name<br>Detection Level                                         | Related Protective Function                                                                                      |
|------------------------|-------------------------------------------------------------------------------------|------------------------------------------------------------------------------------------------------------------|
| OL                     | <b>Overload 1</b><br>Pr. 22 setting [Section 8.5.4]                                 | <b>Acceleration-time overcurrent, constant speed-time overcurrent, deceleration-time overcurrent, stall stop</b> |
| oL                     | <b>Overload 2</b><br>Main circuit DC voltage more than 390V                         | <b>Deceleration-time overvoltage</b>                                                                             |
| FN                     | <b>Fan failure</b><br>Cooling fan fault<br><b>Refer to: Pr. 244 [Section 8.5.5]</b> | <b>Fin overheat</b>                                                                                              |

## 6.1.3 Others

Table 6-4

| Parameter<br>Unit Display            | Name                            | Possible Cause (●) and<br>Corrective Action (•)                                                                                                                                                                                                                                                                                                                                                                                                                    |
|--------------------------------------|---------------------------------|--------------------------------------------------------------------------------------------------------------------------------------------------------------------------------------------------------------------------------------------------------------------------------------------------------------------------------------------------------------------------------------------------------------------------------------------------------------------|
| (Types of<br>error are<br>displayed) | <b>Operation error</b>          | <ul style="list-style-type: none"> <li>● Parameter changing operation was performed during external operation.</li> <li>● The value that was set is outside the parameter setting range.</li> <li>● The RES signal remains ON.</li> <li>● The parameter unit is in a connection fault. <ul style="list-style-type: none"> <li>• Check the fitting status.</li> </ul> </li> </ul> <p><b>MEMO</b> An operation error does not activate the relay contact output.</p> |
| PS                                   | <b>Emergency stop operation</b> | <ul style="list-style-type: none"> <li>● The <span style="border: 1px solid black; padding: 2px;">STOP/RESET</span> key of the parameter unit was pressed to make a stop during external operation.</li> </ul> <p><b>MEMO</b> A reset cannot be made in the normal method.<br/><b>Refer to: Pr. 75 [Section 8.2]</b></p>                                                                                                                                           |

## 6.2 Motor operation out of ordinary

If any of the following faults has occurred in the motor, find out its cause and take adequate measures.

| Event                                                             | Check Point                   | Possible Cause (●) and Corrective Action (●)                                                                                                                                                                                                                                                                                                                                                                                                                     |
|-------------------------------------------------------------------|-------------------------------|------------------------------------------------------------------------------------------------------------------------------------------------------------------------------------------------------------------------------------------------------------------------------------------------------------------------------------------------------------------------------------------------------------------------------------------------------------------|
| Motor remains stopped.                                            | Check the main circuit.       | <ul style="list-style-type: none"> <li>● A normal power supply voltage is not applied.</li> <li>● The jumper across terminals P/+P1 has been disconnected.</li> <li>● The motor is not wired properly.</li> <li>● The switch connected between the motor and drive unit is open.</li> </ul>                                                                                                                                                                      |
|                                                                   | Check the control signals.    | <ul style="list-style-type: none"> <li>● The start signal has not been initiated.</li> <li>● Both the forward and reverse rotation signals are input.</li> <li>● The speed setting signal is not input.</li> <li>● The MRS signal remains ON.</li> </ul>                                                                                                                                                                                                         |
|                                                                   | Check the parameter settings. | <ul style="list-style-type: none"> <li>● The reverse rotation prevention, Pr. 78 [Section 8.5.1], value has been set.</li> <li>● 0 was set as the maximum speed, Pr. 1 [Section 8.5.1], value.</li> </ul>                                                                                                                                                                                                                                                        |
|                                                                   | Check the load.               | <ul style="list-style-type: none"> <li>● The load is too heavy.<br/>(The alarm message OL appears.)</li> <li>● The motor shaft is locked.</li> </ul>                                                                                                                                                                                                                                                                                                             |
|                                                                   | Others                        | <ul style="list-style-type: none"> <li>● The alarm lamp is lit.</li> <li>● The POWER lamp is off.</li> <li>● Terminals PC and SD are shorted.</li> </ul>                                                                                                                                                                                                                                                                                                         |
| Motor rotates in opposite direction.                              | Check the main circuit.       | <ul style="list-style-type: none"> <li>● The wiring of the motor connection terminals U, V, W does not match the motor phase sequence.</li> </ul>                                                                                                                                                                                                                                                                                                                |
|                                                                   | Check the control signals.    | <ul style="list-style-type: none"> <li>● The wiring of the forward rotation signal (terminal STF) and that of the reverse rotation signal (terminal STR) was exchanged.</li> </ul>                                                                                                                                                                                                                                                                               |
| Speed differs from the setting.                                   | Check the control signals.    | <ul style="list-style-type: none"> <li>● The speed setting signal differs from the setting.</li> <li>● The speed setting signal is compounded with noise.</li> </ul>                                                                                                                                                                                                                                                                                             |
|                                                                   | Check the parameter settings. | <ul style="list-style-type: none"> <li>● The speed signal bias/gain, Pr. 902, Pr. 903 [Section 8.3.1], values have been set.</li> <li>● The maximum speed, Pr. 1 [Section 8.5.1], value or minimum speed, Pr. 2 [Section 8.5.1], value has been set.</li> <li>● The stall prevention function was activated. <ul style="list-style-type: none"> <li>• Increase the acceleration or deceleration time setting.</li> <li>• Reduce the load.</li> </ul> </li> </ul> |
| Acceleration/ deceleration is not smooth.                         | Check the parameter settings. | <ul style="list-style-type: none"> <li>● The stall prevention function was activated. <ul style="list-style-type: none"> <li>• Increase the acceleration or deceleration time setting.</li> <li>• Reduce the load.</li> </ul> </li> </ul>                                                                                                                                                                                                                        |
| Speed varies.                                                     | Check the control signals.    | <ul style="list-style-type: none"> <li>● The speed setting signal varies.</li> </ul>                                                                                                                                                                                                                                                                                                                                                                             |
|                                                                   | Check the load.               | <ul style="list-style-type: none"> <li>● The load varies.</li> </ul>                                                                                                                                                                                                                                                                                                                                                                                             |
| At start, motor shaft runs in opposite direction instantaneously. | Check the parameter settings. | <ul style="list-style-type: none"> <li>● The acceleration time setting is more than that for the maximum permissible starting torque. <ul style="list-style-type: none"> <li>• Increase the acceleration time setting.</li> <li>• Reduce the stall prevention operation level in Pr. 22.</li> </ul> </li> </ul>                                                                                                                                                  |

## 6.3 Maintenance and Inspection

### WARNING

- When performing inspection by removing the front cover or the like, switch power off, wait 10 or more minutes, then check that the voltage across the DC terminals P/+-N/- is less than 30VDC with a tester or like before starting inspection. Not doing so can cause an electric shock.
- Any person who is involved in inspection should be fully competent to do the work. Otherwise, an electric shock can occur. Do not disassemble or repair the unit.

### 6.3.1 Inspection

#### (1) Daily inspection

During operation and power-on, visually check for the following faults without removing the cover and like.

- 1) Faulty motor operation
- 2) Improper installation environment (ambient temperature, humidity, dust, dirt, etc.)
- 3) Unusual noise, unusual vibration, foul odor, etc.
- 4) Overheat trace, discoloration, etc.
- 5) Improper cooling fan rotation
- 6) Improper on/off of lamps, LEDs and others
- 7) Improper meter indications

|               |                                                                                                                                                                                                                                                                                                                                                                                                                                                                                                                                             |
|---------------|---------------------------------------------------------------------------------------------------------------------------------------------------------------------------------------------------------------------------------------------------------------------------------------------------------------------------------------------------------------------------------------------------------------------------------------------------------------------------------------------------------------------------------------------|
| <b>NOTICE</b> | <ul style="list-style-type: none"> <li>● Always use the drive unit in a clean status.             <ul style="list-style-type: none"> <li>• When cleaning, always switch power off and gently wipe dirty areas with a soft cloth immersed in neutral detergent or ethanol. Do not use detergent or the like to clean the display section of the parameter unit.</li> <li>• When cleaning, do not use solvent, e.g. acetone, benzene, toluene or alcohol, as they will cause the drive unit surface paint to peel off.</li> </ul> </li> </ul> |
|---------------|---------------------------------------------------------------------------------------------------------------------------------------------------------------------------------------------------------------------------------------------------------------------------------------------------------------------------------------------------------------------------------------------------------------------------------------------------------------------------------------------------------------------------------------------|

#### (2) Periodic inspection

After operation has stopped, switch power off, remove the front cover, and perform periodic inspection referring to Table 6-5 Periodic Inspection List.

Table 6-5 Periodic Inspection List

| Area of Inspection      |                                      | Inspection Items                                                                                                                                                                                                           | Methods                                                                                                     | Criteria                                                                                |
|-------------------------|--------------------------------------|----------------------------------------------------------------------------------------------------------------------------------------------------------------------------------------------------------------------------|-------------------------------------------------------------------------------------------------------------|-----------------------------------------------------------------------------------------|
| Surrounding environment |                                      | 1) Check ambient temperature, humidity, vibration, ambience (for dust, dirt, gas, oil mist, water drops, etc.)<br>2) Check for tools, foreign matter and dangerous articles in the periphery.                              | 1) Measure visually or with instruments.<br>• Thermometer<br>• Hygrometer<br>• Recorder<br>2) Visual check. | 1) Standard specification values must be satisfied.<br>2) Must not be left unrecovered. |
| Overall unit            |                                      | Check for unusual vibration and unusual noise.                                                                                                                                                                             | Visual and auditory checks.                                                                                 | No fault.                                                                               |
| Main circuit            | General                              | 1) Check for loose screws and bolts.<br>2) Check parts and members for deformation, crack, damage, and discoloration caused by overheat or deterioration.<br>3) Check for contamination and sticking dust and dirt.        | 1) Retighten.<br>2), 3) Visual check.                                                                       | 1), 2), 3)<br>No fault.                                                                 |
|                         | Conductors, cables                   | 1) Check conductors for discoloration and distortion caused by overheat.<br>2) Check cable sheaths for breakage and discoloration.                                                                                         | 1), 2) Visual check.                                                                                        | 1), 2) No fault.                                                                        |
|                         | Terminal block                       | Check for damage.                                                                                                                                                                                                          | Visual check.                                                                                               | No fault.                                                                               |
|                         | Smoothing capacitor                  | 1) Check for liquid leakage, discoloration, crack and casing expansion.<br>2) Check for projected safety valve.<br>3) Measure capacitance.                                                                                 | 1), 2) Visual check.<br>3) Use capacitance meter for measurement.                                           | 1), 2) No fault.<br>3) 85% or more of rated capacitance.                                |
|                         | Resistor                             | Check for foul odor and insulation crack due to overheat.                                                                                                                                                                  | Olfactory, visual checks.                                                                                   | No fault.                                                                               |
| Control circuit         | Control printed circuits, connectors | 1) Check for loose screws, bolts and connectors.<br>2) Check for unusual odor and discoloration.<br>3) Check for crack, damage, deformation, and rust.<br>4) Check capacitor for liquid leakage and traces of deformation. | 1) Retighten.<br>2) Olfactory, visual checks.<br>3), 4) Visual check.                                       | 1), 2), 3), 4)<br>No fault.                                                             |
| Cooling system          | Cooling fan                          | 1) Check for sticking foreign matter.<br>2) Check for loose connection.                                                                                                                                                    | 1) Hand turn.<br>2) Visual check                                                                            | 1) Smooth turn.<br>2) No fault.                                                         |
|                         | Ventilation path                     | Check for clogged heat sink, suction/exhaust ports, and sticking foreign matter.                                                                                                                                           | Visual check.                                                                                               | No fault.                                                                               |

**NOTICE**

- **Insulation resistance test using megger**  
Where possible, do not conduct an insulation resistance test using a megger since an insulation test has been done before shipment from the factory. When it is inevitable to make an insulation resistance test using a megger, disconnect all cables from the control circuit to prevent a test voltage from leaking into the control circuit. The drive unit will fail if the test voltage is applied to the control circuit.

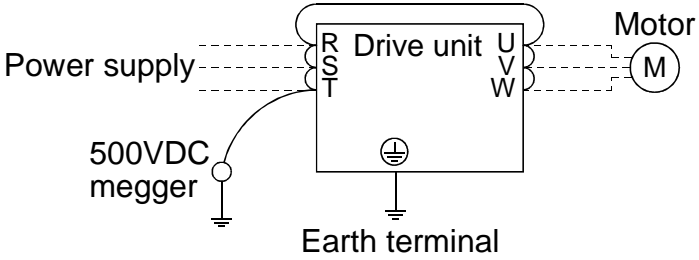

- **Pressure test**  
Do not conduct a pressure test. A pressure test can deteriorate the semiconductor parts in the drive unit.

### 6.3.2 Wear parts

The replacement lives of the parts are as indicated below. Since the lives vary with the operating environment and/or usage, you must replace the parts if you have found any fault during periodic inspection or the like.

| Part Name                        | Standard Replacement Intervals | Method               | Remarks                                                                                                                                                                                                                                                                         |
|----------------------------------|--------------------------------|----------------------|---------------------------------------------------------------------------------------------------------------------------------------------------------------------------------------------------------------------------------------------------------------------------------|
| Cooling fan                      | 2 to 3 years                   | Change (as required) | The bearing life of the cooling fan is 10,000 to 35,000 hours. For continuous operation, therefore, normally replace the fan every 2 to 3 years as a guideline.                                                                                                                 |
| Main circuit smoothing capacitor | 5 years                        | Change (as required) | The life greatly depends on the ambient temperature and operation specifications of the drive unit. When continuous operation is performed in normal air-conditioned environment, the life is approximately 5 years. The life halves for each 10°C rise in ambient temperature. |
| On-board smoothing capacitor     | 5 years                        | Change (as required) | The capacitor deteriorates rapidly after the given period has elapsed, causing the motor to run unstably or activating the overcurrent protective function.                                                                                                                     |



### 6.3.3 Cooling fan replacement method

#### ● Removal

- 1) Remove the wiring cover.
- 2) Unplug the fan connector.

The cooling fan is connected with the cooling fan connector on the drive unit terminal block side.

Unplug the connector and remove the drive unit and cooling fan.

- 3) Remove the cooling fan cover.

Push the cover in the direction of arrows and pull it down.

- 4) Remove the cooling fan and cooling fan cover.

The cooling fan is secured by latches.

The cooling fan and cooling fan cover can be removed by disengaging the latches.

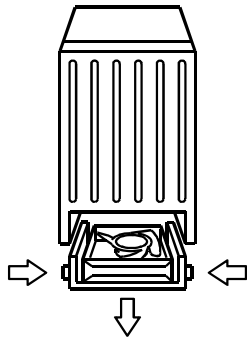

#### ● Reinstallation

- 1) After confirming the orientation of the fan, reinstall the fan to the cover so that the arrow on the left of "AIR FLOW" faces in the opposite direction of the fan cover.

Note: The wrong direction of air flow can shorten the drive unit life.

- 2) Reinstall the fan cover to the drive unit. Pass the wiring through the wiring groove to avoid it from being caught between the chassis and cover.
- 3) Connect the wiring to the connector.
- 4) Reinstall the wiring cover.

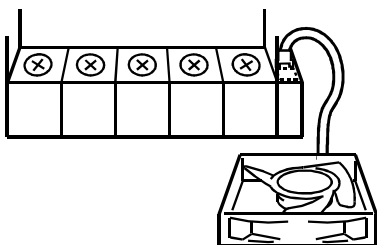

## 7. SPECIFICATIONS

### 7.1 Standard Specifications

#### 7.1.1 Rating specifications

| MD-CX522-□□                    |                                      | 0.4K                                             | 0.75K       | 1.5K | 2.2K | 3.7K |
|--------------------------------|--------------------------------------|--------------------------------------------------|-------------|------|------|------|
| Applicable motor capacity (kW) |                                      | 0.4                                              | 0.75        | 1.5  | 2.2  | 3.7  |
| Output                         | Overload capacity                    | 150% 60s (inverse-time characteristics)          |             |      |      |      |
|                                | Regenerative braking torque (Note 1) | 10% or more                                      | 5% or more  |      |      |      |
| Power supply                   | Rated input AC voltage               | Three phase, 200V to 220V 50Hz, 200 to 230V 60Hz |             |      |      |      |
|                                | Permissible AC voltage fluctuation   | 170 to 242V 50Hz, 170 to 253V 60Hz               |             |      |      |      |
|                                | Permissible frequency fluctuation    | ±5%                                              |             |      |      |      |
|                                | Power supply system capacity (kVA)   | 1.1                                              | 2.2         | 3.1  | 4.3  | 7.3  |
| Protective structure           |                                      | Enclosed type (IP20)                             |             |      |      |      |
| Cooling system                 |                                      | Self-cooling                                     | Air cooling |      |      |      |
| Approx. weight (kg)            |                                      | 8.0                                              | 1.0         | 1.7  | 1.7  | 2.2  |

Note 1: Indicates the short-duration average torque (which varies with motor loss) provided when a motor alone is decelerated from the rated speed at the shortest time, and does not indicate continuous regenerative torque. Since the drive unit does not have a built-in brake resistor, use an optional brake resistor when regenerative energy is large. You can also use the brake unit (model BU).

|             |                                                                                                                                                                                                                                                                                                                                                                                                                                                                                                                                                                                                                                                                                      |
|-------------|--------------------------------------------------------------------------------------------------------------------------------------------------------------------------------------------------------------------------------------------------------------------------------------------------------------------------------------------------------------------------------------------------------------------------------------------------------------------------------------------------------------------------------------------------------------------------------------------------------------------------------------------------------------------------------------|
| <b>MEMO</b> | <ul style="list-style-type: none"> <li>● The rated output capacity and rated speed of the motor used with the drive unit assume the rated input AC voltage indicated above. They cannot be guaranteed when the power supply voltage drops.</li> <li>● The overload capacity indicated in % is the ratio of the overload current to the motor's rated output.</li> <li>● The power supply system capacity varies with the values of the power supply side impedances (including those of the input reactor and cables).</li> <li>● The permissible load inertia moment ratio to the motor shaft is 15 times or less.</li> <li>● The drive unit cannot run multiple motors.</li> </ul> |
|-------------|--------------------------------------------------------------------------------------------------------------------------------------------------------------------------------------------------------------------------------------------------------------------------------------------------------------------------------------------------------------------------------------------------------------------------------------------------------------------------------------------------------------------------------------------------------------------------------------------------------------------------------------------------------------------------------------|

## 7.1.2 Common specifications

### (1) Control specifications

|                                                     |                      |                                                                               |
|-----------------------------------------------------|----------------------|-------------------------------------------------------------------------------|
| <b>Control system</b>                               |                      | Sensor-less PWM control                                                       |
| <b>Carrier frequency</b>                            |                      | 7.5kHz fixed                                                                  |
| <b>Max. output speed</b>                            |                      | 7200r/min (output frequency 240Hz)                                            |
| <b>Speed setting resolution</b>                     | <b>Analog input</b>  | 1/1000 of the max. preset speed<br>1/500 when 5VDC is selected                |
|                                                     | <b>Digital input</b> | 1r/min                                                                        |
| <b>Speed output resolution</b>                      |                      | 0.3r/min                                                                      |
| <b>Speed accuracy</b>                               | <b>Analog input</b>  | Within $\pm 0.5\%$ of maximum output speed                                    |
|                                                     | <b>Digital input</b> | Within $\pm 0.05\%$ of maximum output speed                                   |
| <b>Starting torque</b>                              |                      | 120% or more                                                                  |
| <b>Speed control range</b>                          |                      | 1 : 10                                                                        |
| <b>Initial magnetic pole detection time</b>         |                      | Approx. 0.1s (85ms $\pm$ 15ms)                                                |
| <b>Acceleration/deceleration time setting range</b> |                      | 0.5 to 60.0s<br>(acceleration and deceleration can be set individually)       |
| <b>Stall prevention operation level</b>             |                      | Operation level can be set (60 to 200%), presence or absence can be selected. |

**(2) Operational specifications**

|                                 |                                                  |                                                                                                                                                                                                                                                                                                                                |
|---------------------------------|--------------------------------------------------|--------------------------------------------------------------------------------------------------------------------------------------------------------------------------------------------------------------------------------------------------------------------------------------------------------------------------------|
| <b>Operation method</b>         | <b>PU operation</b>                              | Parameter unit (option) operation                                                                                                                                                                                                                                                                                              |
|                                 | <b>External operation</b>                        | Operation using external analog/contact signals                                                                                                                                                                                                                                                                                |
|                                 | <b>Communication operation</b>                   | Communication operation using RS-485 8-pole, 8-core modular connector, 1 channel                                                                                                                                                                                                                                               |
| <b>Terminal functions</b>       | <b>Speed command</b>                             | Analog input, 1 channels                                                                                                                                                                                                                                                                                                       |
|                                 | <b>Voltage input</b>                             | DC0 to 10V/DC0 to 5V                                                                                                                                                                                                                                                                                                           |
|                                 | <b>Start/stop</b>                                | Contact input, 2 channels<br>(Forward rotation/stop, reverse rotation/stop)                                                                                                                                                                                                                                                    |
|                                 | <b>Reset</b>                                     | Contact input, 1 channel                                                                                                                                                                                                                                                                                                       |
|                                 | <b>Operation function input signal selection</b> | Contact input, 4 channels                                                                                                                                                                                                                                                                                                      |
|                                 | <b>Selection signals</b>                         | Multi-speed operation (up to 7 speeds), output stop                                                                                                                                                                                                                                                                            |
|                                 | <b>Alarm output</b>                              | Relay changeover contact output, 1 channel                                                                                                                                                                                                                                                                                     |
|                                 | <b>Operation status output signal selection</b>  | Open collector output, 2 channels                                                                                                                                                                                                                                                                                              |
|                                 | <b>Selection signals</b>                         | Running, overload alarm, speed detection (1 points), output current detection, fault detection                                                                                                                                                                                                                                 |
|                                 | <b>Meter output signal selection</b>             | Pulse train output, 1 channel                                                                                                                                                                                                                                                                                                  |
| <b>Selection signals</b>        | Motor speed, motor current, preset speed         |                                                                                                                                                                                                                                                                                                                                |
| <b>Protective functions</b>     |                                                  | Overcurrent (acceleration, deceleration, constant speed), regenerative overvoltage (acceleration, deceleration, constant speed), undervoltage, overload (electronic overcurrent protection), brake transistor alarm, output short circuit, brake resistor overheat, fin overheat, parameter error, PU disconnection, CPU error |
| <b>Alarm functions</b>          |                                                  | Overload, fan failure, undervoltage                                                                                                                                                                                                                                                                                            |
| <b>Parameter unit functions</b> | <b>Operation commands</b>                        | Start (forward rotation/reverse rotation) and stop made by operation of individual keys                                                                                                                                                                                                                                        |
|                                 |                                                  | Speed command given by operation of ten-key pad                                                                                                                                                                                                                                                                                |
|                                 | <b>Monitor items</b>                             | Motor speed, motor current, output voltage, alarm display, preset speed                                                                                                                                                                                                                                                        |
|                                 | <b>Others</b>                                    | Alarm history storage (8 alarms), parameter copy function                                                                                                                                                                                                                                                                      |

**(3) Environmental specifications**

|                            |                                                                             |
|----------------------------|-----------------------------------------------------------------------------|
| <b>Ambient temperature</b> | -10°C to +50°C (non-freezing)                                               |
| <b>Ambient humidity</b>    | 90%RH or less (non-condensing)                                              |
| <b>Storage temperature</b> | -20°C to +65°C (applies to short-time transit, etc.)                        |
| <b>Ambience</b>            | Indoors.<br>(No corrosive and flammable gases, oil mist, dust and dirt.)    |
| <b>Altitude, vibration</b> | Max. 1000m above sea level, 5.9m/s <sup>2</sup><br>(conforms to JIS C 0040) |

7.1.3 Outline drawings

CX522-0.4K, 0.75K

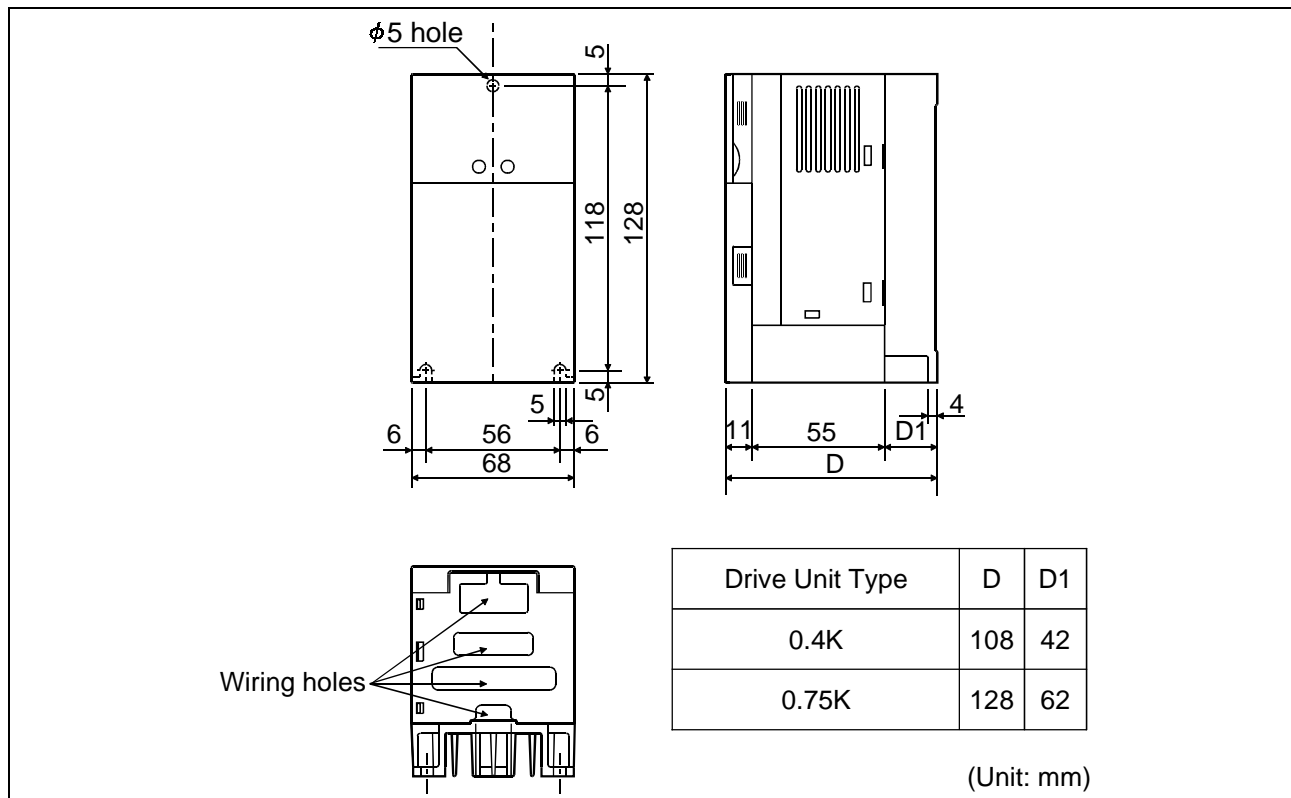

CX522-1.5K, 2.2K

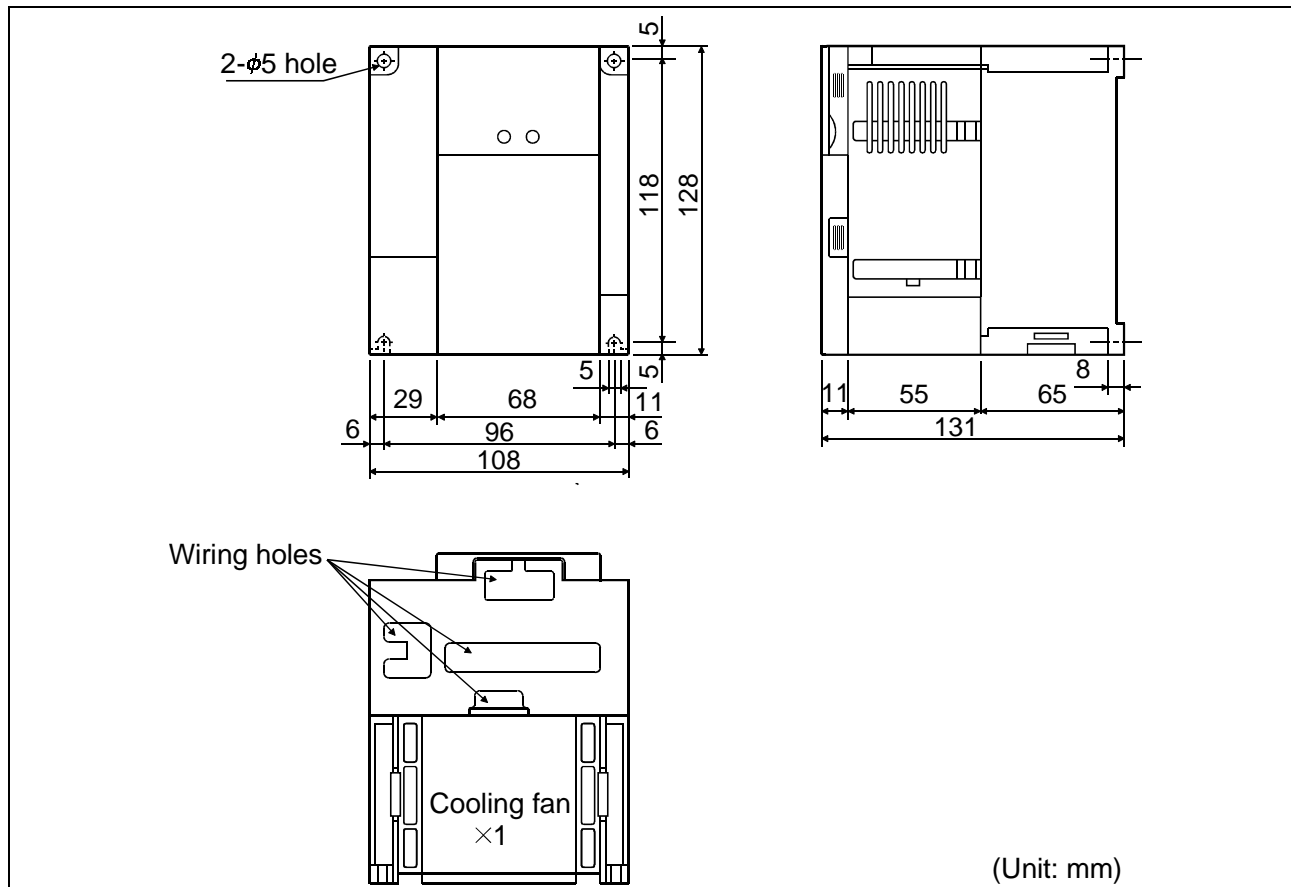

CX522-3.7K

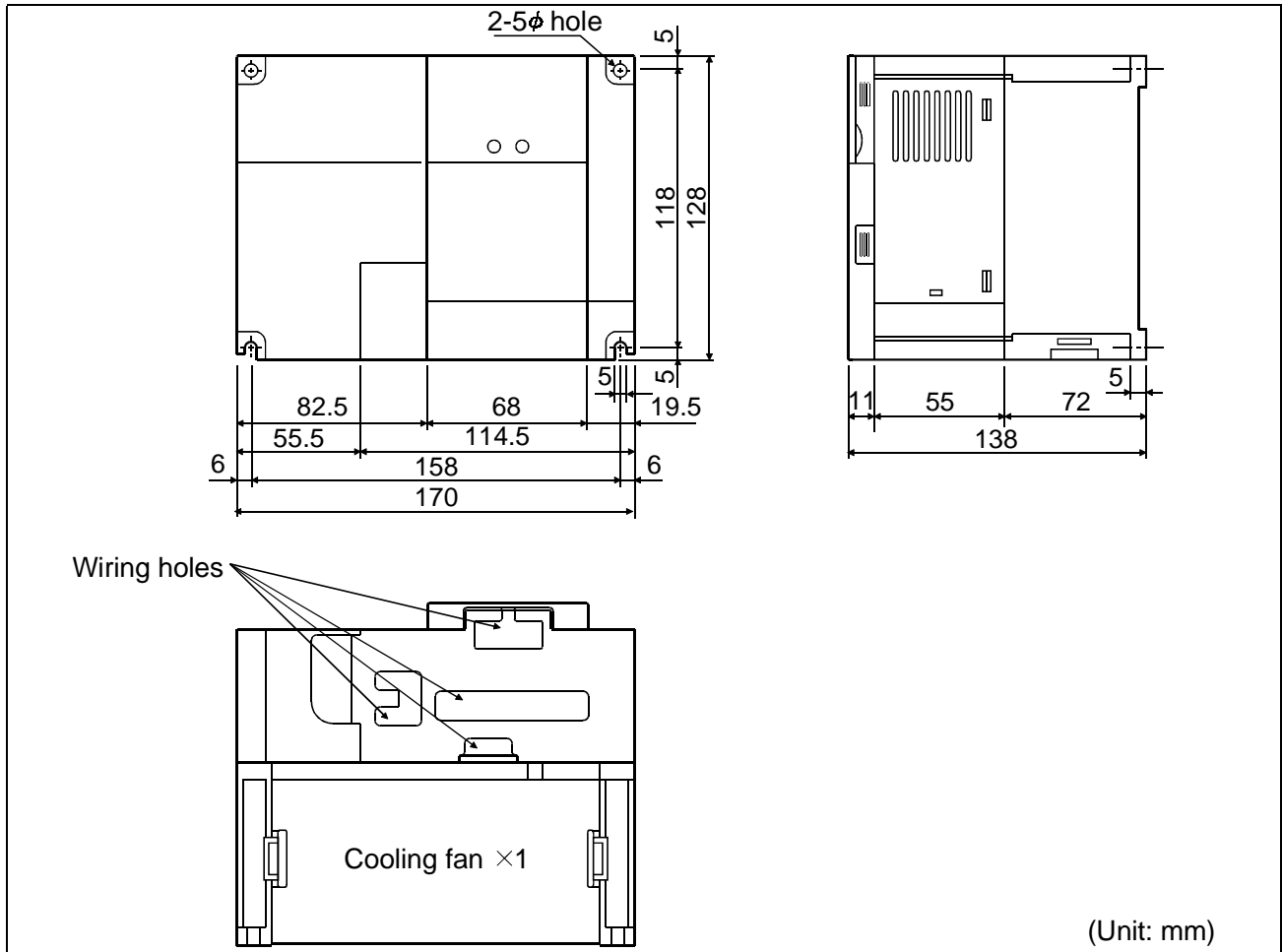

Parameter unit (FR-PU04)

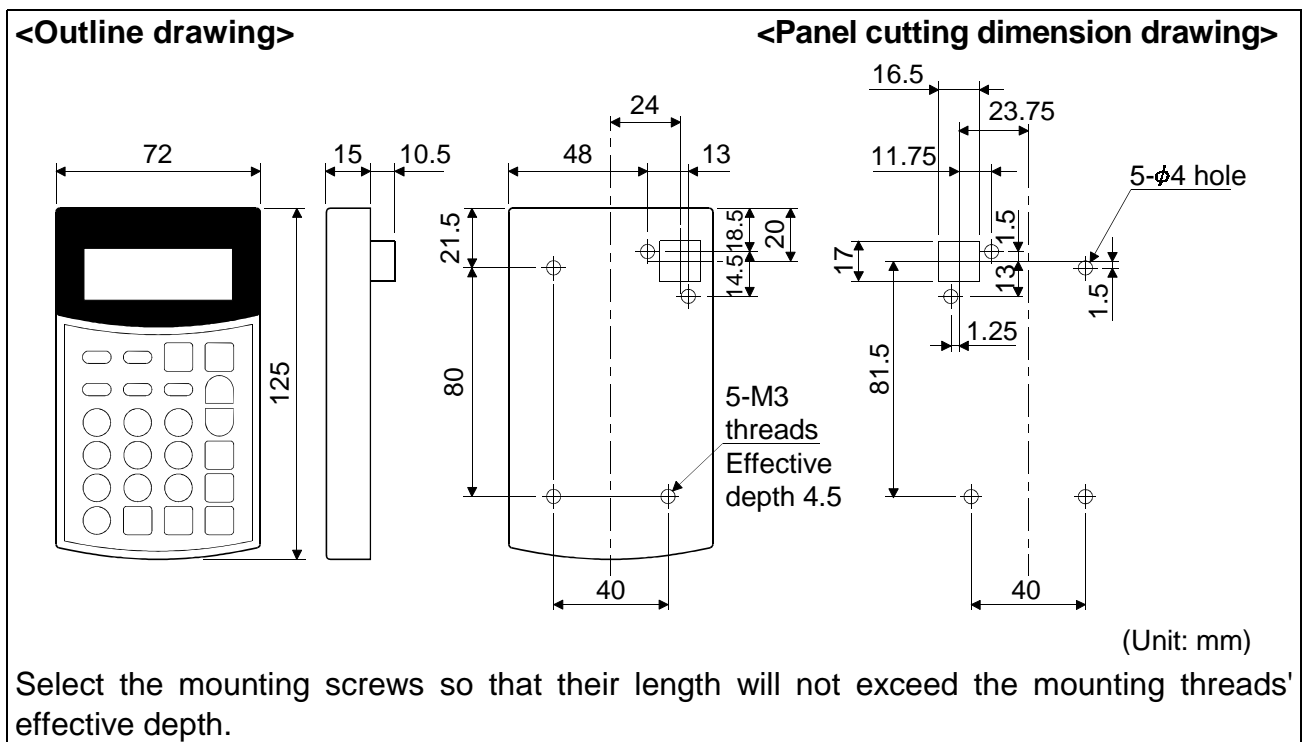

## 8. PARAMETER FUNCTIONS

Refer to Appendix 1 for the parameter list.

|             |                                                                                                                                                                                                                                                                                                                                                                                                                                                                                                                                                                                                                                                                                                                                                                                     |
|-------------|-------------------------------------------------------------------------------------------------------------------------------------------------------------------------------------------------------------------------------------------------------------------------------------------------------------------------------------------------------------------------------------------------------------------------------------------------------------------------------------------------------------------------------------------------------------------------------------------------------------------------------------------------------------------------------------------------------------------------------------------------------------------------------------|
| <b>MEMO</b> | <ul style="list-style-type: none"> <li>● The minimum increment of the setting is 0.1 in the setting range 0.0 to 60.0, or 1 in the range 0 to 60.</li> <li>● The value having a 0 on the right of the decimal point can be entered as an integer. (Example: 10.0 → 10)</li> <li>● If any parameter cannot be set, check that:             <ul style="list-style-type: none"> <li>• The start signal (STF or STR) is not "ON".</li> <li>• The parameter write disable selection (Pr. 77) setting has not been made.</li> <li>• The PU operation mode has not been selected.</li> </ul> </li> <li>● When the PU operation mode cannot be selected, check that:             <ul style="list-style-type: none"> <li>• The start signal (STF or STR) is not "ON".</li> </ul> </li> </ul> |
|-------------|-------------------------------------------------------------------------------------------------------------------------------------------------------------------------------------------------------------------------------------------------------------------------------------------------------------------------------------------------------------------------------------------------------------------------------------------------------------------------------------------------------------------------------------------------------------------------------------------------------------------------------------------------------------------------------------------------------------------------------------------------------------------------------------|

### 8.1 Protection and Editing of the Parameters

#### Pr. 77 "parameter write disable selection"

You can select between write-enable and disable for parameter setting.

| Setting | Function                                                                                                                                                               | Exceptional Parameters                                                                                                                                                                                               |
|---------|------------------------------------------------------------------------------------------------------------------------------------------------------------------------|----------------------------------------------------------------------------------------------------------------------------------------------------------------------------------------------------------------------|
| 0       | You can change the setting only during a stop in the PU operation mode.                                                                                                | Even during operation, you can change the values of the parameters whose numbers are  shaded in the parameter list in Appendix 1. |
| 1       | Whether the motor is running or at a stop, you cannot change the settings in any operation mode.<br>Parameter clear, parameter all clear operations are also disabled. | Pr. 22 [Section 8.5.4], Pr. 75 [Section 8.2], and Pr. 77, Pr. 188 [Section 8.4] allow their values to be changed in any operation mode.                                                                              |
| 2       | Whether the motor is running or at a stop, you can change the values in any operation mode.                                                                            | Pr. 189 [Section 8.4], and Pr. 190, Pr.194 [Section 8.7.2] allow their values to be changed during a stop only.                                                                                                      |

## 8.2 Parameter Unit Operation Selection

### Pr. 75 "disconnected PU detection/PU stop selection"

#### ● Disconnected PU detection function

You can make selection between continued operation or an alarm stop ("PUヌケハツセイ" indication) when the FR-PU04 parameter unit has come off the drive unit during operation.

|             |                                                                                             |
|-------------|---------------------------------------------------------------------------------------------|
| <b>MEMO</b> | ● This function is invalid if power is switched on with the FR-PU04 parameter unit removed. |
|-------------|---------------------------------------------------------------------------------------------|

#### ● PU stop selection

Select the operation mode in which an operation stop is made valid by the STOP/RESET key of the FR-PU04 parameter unit.

| Setting | PU Disconnection Detection Function | PU Stop Selection Operation Mode                                                                                             |
|---------|-------------------------------------|------------------------------------------------------------------------------------------------------------------------------|
| 0       | Operation continued.                | Any operation mode.                                                                                                          |
| 1       | Alarm stop.                         | When operation is stopped in the external operation mode, "PS" appears in the main indicator LED. No alarm signal is output. |
| 2       | Operation continued.                | PU operation mode.                                                                                                           |
| 3       | Alarm stop.                         |                                                                                                                              |

### Restarting method when "PS" appears in the main indicator LED

To restart operation, turn "OFF" the operation command (STF or STR) signal, perform the following operation, and then turn "ON" the operation command.

- 1) Press the EXT key of the parameter unit.

|             |                                                                                             |
|-------------|---------------------------------------------------------------------------------------------|
| <b>MEMO</b> | ● Pr. 75 does not return to the initial value if parameter clear or all clear is performed. |
|-------------|---------------------------------------------------------------------------------------------|



## 8.3 Selection of the Speed Command

### 8.3.1 Selection of the analog speed command specifications

#### Pr. 73 "speed command range selection"

You can select the value of the voltage signal entered to terminal 2.

| Setting | Terminal 2 Input Voltage |
|---------|--------------------------|
| 0       | 0 to 10V                 |
| 1       | 0 to 5V                  |

#### Pr. 74 "filter time constant"

You can set the filter time constants of the speed command input terminals (terminals 2). Increase the value if stable operation cannot be performed due to the influence of noise on the speed command signal. Decreasing the value makes the speed command signal more susceptible to noise but the response of the speed command faster. Conversely, increasing the value makes the speed command signal less susceptible to noise but the response of the speed command slower.

| Setting |
|---------|
| 0 to 8  |

#### Pr. 902 "speed setting voltage bias"

#### Pr. 903 "speed setting voltage gain"

You can set the relationship between the magnitude of the speed setting analog voltage signal input to the terminal 2 and the motor speed. 0V of the speed setting signal corresponds to approx. 0%, and 5V or 10V (depending on Pr. 73 setting) to approx. 100%.

For details of the calibration method, refer to the instruction manual of the FR-PU04 parameter unit.

| Pr. | Setting Range |       |                      |      |
|-----|---------------|-------|----------------------|------|
|     | Motor speed   | Unit  | Speed setting signal | Unit |
| 902 | 0 to 7200     | r/min | 0.0 to 300.0         | %    |
| 903 | 1 to 7200     |       | 0.0 to 300.0         |      |

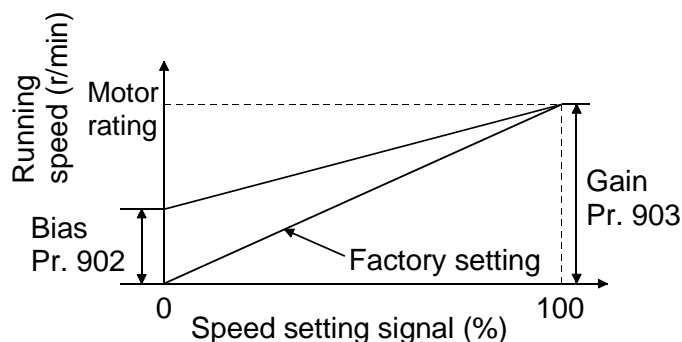

### 8.3.2 Variable-speed operation using contact input signals

Pr. 4 "three-speed setting (high speed)"

Pr. 5 "three-speed setting (middle speed)"

Pr. 6 "three-speed setting (low speed)"

Pr. 24 to 27 "multi-speed setting (speed 4 to 7)"

| Pr.      | Setting Range | Unit  |
|----------|---------------|-------|
| 4 to 6   | 0 to 7200     | r/min |
| 24 to 27 | 0 to 7200     |       |
|          |               | 9999  |

Combining "ON"/"OFF" of the contact signals allows you to choose the preset running speed (any of up to seven different speeds).

The following table lists the relationships between the contact signal input combinations and running speeds.

| Speed   | Contact Signal Input |     |     | Running Speed Setting Parameter | Remarks                                                                                                                                                                                                                                                                                                                                                                   |
|---------|----------------------|-----|-----|---------------------------------|---------------------------------------------------------------------------------------------------------------------------------------------------------------------------------------------------------------------------------------------------------------------------------------------------------------------------------------------------------------------------|
|         | RH                   | RM  | RL  |                                 |                                                                                                                                                                                                                                                                                                                                                                           |
| Speed 1 | ON                   | OFF | OFF | Pr. 4                           | When two or more contact signals are "ON", priority is given to the signals in order of terminals RL, RM and RL.<br><br>When performing multi-speed operation at speeds 4 and higher, set the running speeds in the corresponding parameters.<br><br>When "9999" is set in the parameter, input of the corresponding signal performs operation at the lower preset speed. |
| Speed 2 | OFF                  | ON  | OFF | Pr. 5                           |                                                                                                                                                                                                                                                                                                                                                                           |
| Speed 3 | OFF                  | OFF | ON  | Pr. 6                           |                                                                                                                                                                                                                                                                                                                                                                           |
| Speed 4 | OFF                  | ON  | ON  | Pr. 24                          |                                                                                                                                                                                                                                                                                                                                                                           |
| Speed 5 | ON                   | OFF | ON  | Pr. 25                          |                                                                                                                                                                                                                                                                                                                                                                           |
| Speed 6 | ON                   | ON  | OFF | Pr. 26                          |                                                                                                                                                                                                                                                                                                                                                                           |
| Speed 7 | ON                   | ON  | ON  | Pr. 27                          |                                                                                                                                                                                                                                                                                                                                                                           |

|             |                                                                                                                                                                                                                                                                                          |
|-------------|------------------------------------------------------------------------------------------------------------------------------------------------------------------------------------------------------------------------------------------------------------------------------------------|
| <b>MEMO</b> | <ul style="list-style-type: none"> <li>● Simultaneous input of the multi-speed operation signal and analog speed signal (across terminals 2-5) gives priority to the multi-speed operation signal.</li> <li>● Any setting less than 300r/min will be a stop (0r/min) setting.</li> </ul> |
|-------------|------------------------------------------------------------------------------------------------------------------------------------------------------------------------------------------------------------------------------------------------------------------------------------------|

## 8.4 Selection of the Control Circuit Contact Input Terminal Functions

### Pr. 188 "RES terminal operation selection"

Select the reset operation of the RES terminal. Reset operation is performed when RES-SD are shorted more than 0.1s.

| Setting | Name               | Function                                                                                                                                                                                                                                              |
|---------|--------------------|-------------------------------------------------------------------------------------------------------------------------------------------------------------------------------------------------------------------------------------------------------|
| 0       | CPU reset          | The cumulative thermal value of the electronic overcurrent protection stored during operation is initialized. The alarm status is canceled. Performing reset operation during operation coasts the motor, and canceling the reset restarts the motor. |
| 1       | CPU reset at alarm | The alarm status is canceled. At this time, the cumulative thermal value of the electronic overcurrent protection is also initialized. A reset input is not accepted during normal operation.                                                         |

|             |                                                                                                                                                                                                                                                                                                                            |
|-------------|----------------------------------------------------------------------------------------------------------------------------------------------------------------------------------------------------------------------------------------------------------------------------------------------------------------------------|
| <b>MEMO</b> | <ul style="list-style-type: none"> <li>● The reset operation performed using the <b>STOP/RESET</b> key of the parameter unit will result in an alarm reset regardless of the Pr. 188 setting.</li> <li>● The Pr. 188 setting does not return to the initial value if parameter clear or all clear is performed.</li> </ul> |
|-------------|----------------------------------------------------------------------------------------------------------------------------------------------------------------------------------------------------------------------------------------------------------------------------------------------------------------------------|

### Pr. 189 "STF, STR terminal operation selection"

You can turn the terminal STF into a start/stop function and the terminal STR into a direction of rotation direction switching function.

| Setting | Forward Rotation Operation |     | Reverse Rotation Operation |     | Stop |     |
|---------|----------------------------|-----|----------------------------|-----|------|-----|
|         | STF                        | STR | STF                        | STR | STF  | STR |
| 0       | ON                         | OFF | OFF                        | ON  | OFF  | OFF |
|         |                            |     |                            |     | ON   | ON  |
| 1       | ON                         | OFF | ON                         | ON  | OFF  | OFF |
|         |                            |     |                            |     | OFF  | ON  |

## 8.5 Setting of the Operation Pattern

### 8.5.1 Running speed region

Pr. 1 "maximum speed"

Pr. 2 "minimum speed"

| Pr. | Setting Range | Unit  | Operation                                                                                                                                                                                                                                         |
|-----|---------------|-------|---------------------------------------------------------------------------------------------------------------------------------------------------------------------------------------------------------------------------------------------------|
| 1   | 0 to 7200     | r/min | If the speed command entered is more than the maximum speed set in Pr. 1, the running speed is clamped at the maximum speed.                                                                                                                      |
| 2   | 0 to 7200     | r/min | If the speed command entered is less than the minimum speed set in Pr. 2, the running speed will not fall below the minimum speed.<br>If the speed command is not input, turning "ON" the start signal will start operation at the minimum speed. |

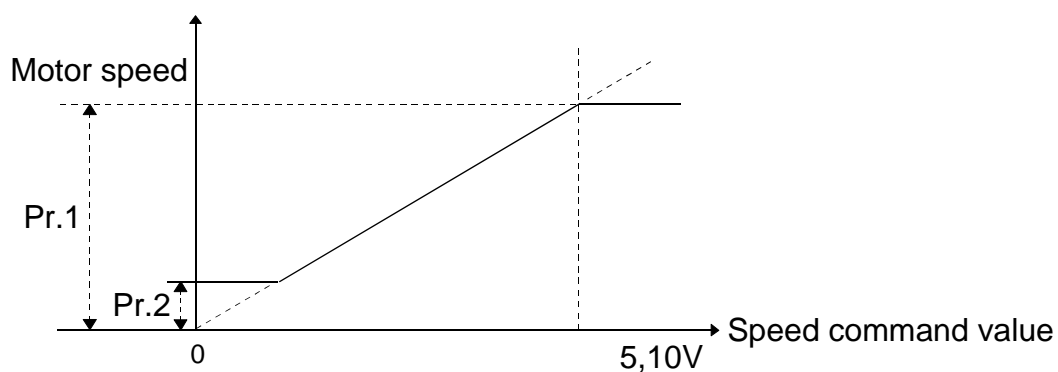

**Pr. 31 to 36 "speed command jumps 1A to 3B"**

| Pr.      | Setting Range   | Unit  |
|----------|-----------------|-------|
| 31 to 36 | 0 to 7200, 9999 | r/min |

You can set three speed areas where continuous operation will be disabled. You can avoid continuous operation at the speed at which resonance will occur due to the natural frequency of a mechanical system. When the speed command within the setting range is input, continuous operation is performed at the preset speed of value A.

Setting "9999" in the parameter makes this function invalid.

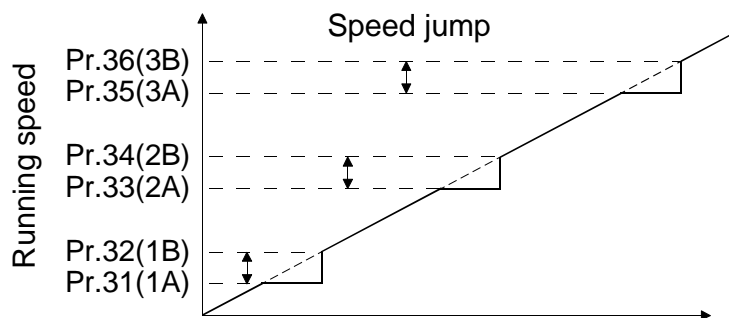

|             |                                                                                                                                                                                                                                                                                                                                                                                               |
|-------------|-----------------------------------------------------------------------------------------------------------------------------------------------------------------------------------------------------------------------------------------------------------------------------------------------------------------------------------------------------------------------------------------------|
| <b>MEMO</b> | <ul style="list-style-type: none"> <li>● The "speed command jump" function is designed to disable continuous operation between the preset A and B points. When the running speed command is outside A-B, the speed varies between A and B in accordance with the preset acceleration/deceleration time.</li> <li>● Any setting less than 300r/min will be a stop (0r/min) setting.</li> </ul> |
|-------------|-----------------------------------------------------------------------------------------------------------------------------------------------------------------------------------------------------------------------------------------------------------------------------------------------------------------------------------------------------------------------------------------------|

**Pr. 78 "reverse rotation prevention selection"**

You can fix the direction of rotation.

| Setting | Function                                                                                                                                                   |
|---------|------------------------------------------------------------------------------------------------------------------------------------------------------------|
| 0       | Forward or reverse rotation operation is performed in accordance with the forward or reverse rotation command.                                             |
| 1       | Forward rotation operation is performed in accordance with the forward rotation command. Operation is stopped in response to the reverse rotation command. |
| 2       | Reverse rotation operation is performed in accordance with the reverse rotation command. Operation is stopped in response to the forward rotation command. |

## 8.5.2 Acceleration time and deceleration time

|        |                                             |
|--------|---------------------------------------------|
| Pr. 7  | "acceleration time"                         |
| Pr. 8  | "deceleration time"                         |
| Pr. 20 | "acceleration/deceleration reference speed" |

| Pr.  | Setting Range | Unit  |
|------|---------------|-------|
| 7, 8 | 0.00 to 60.00 | s     |
| 20   | 1 to 7200     | r/min |

In Pr. 7, set the time required to increase the speed from a start to the speed set in Pr. 20.

In Pr. 8, set the time required to decrease the speed from the speed set in Pr. 20 to a stop.

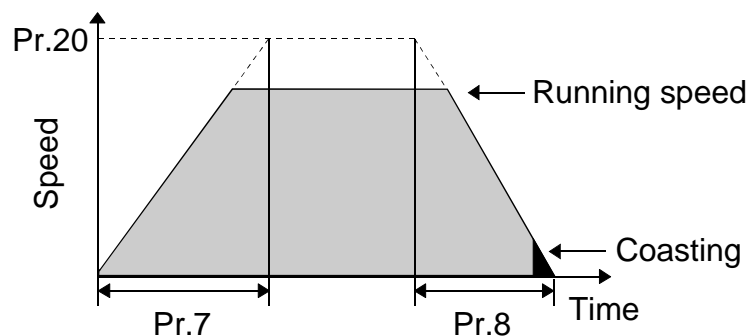

|             |                                                                                                                                                                                                                                                                                                                                                                                                                                                                                                                                                                                                                                                                                                                                                                                                                                                                                                                                                                                                                                                                                                                                                                                                                                                                                         |
|-------------|-----------------------------------------------------------------------------------------------------------------------------------------------------------------------------------------------------------------------------------------------------------------------------------------------------------------------------------------------------------------------------------------------------------------------------------------------------------------------------------------------------------------------------------------------------------------------------------------------------------------------------------------------------------------------------------------------------------------------------------------------------------------------------------------------------------------------------------------------------------------------------------------------------------------------------------------------------------------------------------------------------------------------------------------------------------------------------------------------------------------------------------------------------------------------------------------------------------------------------------------------------------------------------------------|
| <b>MEMO</b> | <ul style="list-style-type: none"> <li>● The minimum value of acceleration/deceleration time is 0.5s. Any acceleration/deceleration time setting of less than 0.5 is handled as 0.5s.</li> <li>● The upper limit of acceleration time at up to 500r/min is 20s (conversion value up to rated speed). When the acceleration time setting is greater than 20s, therefore, the acceleration time required to reach the acceleration/deceleration reference speed is represented by the following expression and is shorter than the preset acceleration time:<br/>       Required acceleration time = <math>1.4 + T1</math><br/> <math>T1 = (\text{preset speed command} - 500) \times \text{Pr. 7 setting} / \text{Pr. 20 setting}</math></li> <li>● During deceleration, the motor will coast at less than 300r/min. Therefore, the time required for deceleration from the speed set in Pr. 20 to 300r/min is as follows:<br/>       Required deceleration time = <math>\text{Pr. 8 setting} \times (\text{Pr. 20 setting} - 300) / \text{Pr. 20 setting}</math></li> <li>● A too short acceleration/deceleration time setting can cause an abnormal stop due to overload, overcurrent or overvoltage. Make a setting which will not display overload on the parameter unit.</li> </ul> |
|-------------|-----------------------------------------------------------------------------------------------------------------------------------------------------------------------------------------------------------------------------------------------------------------------------------------------------------------------------------------------------------------------------------------------------------------------------------------------------------------------------------------------------------------------------------------------------------------------------------------------------------------------------------------------------------------------------------------------------------------------------------------------------------------------------------------------------------------------------------------------------------------------------------------------------------------------------------------------------------------------------------------------------------------------------------------------------------------------------------------------------------------------------------------------------------------------------------------------------------------------------------------------------------------------------------------|

### 8.5.3 Selection of regenerative brake unit

Pr. 30 "regenerative brake option selection"

Pr. 70 "regenerative brake duty"

| Pr. | Setting Range | Unit |
|-----|---------------|------|
| 30  | 0, 1          | —    |
| 70  | 0.0 to 15.0   | %    |

Set Pr. 30 and Pr. 70 according to the regenerative brake unit used. At the setting of Pr. 30 = 0, the Pr. 70 "regenerative brake duty" value is fixed at 3% and Pr. 70 cannot be read.

When Pr. 30 = 1, set the value given in the following table since Pr. 70 setting is enabled.

| Regenerative Brake Option                   | Pr. 30 | Pr. 70 |
|---------------------------------------------|--------|--------|
| MRS brake resistor (option)                 | 0      | —      |
| BU-□□ brake unit (option)                   | 0      | —      |
| FR-ABR-□□ high-duty brake resistor (option) | 1      | 10     |

#### CAUTION

- Do not set the Pr. 70 value which exceeds the setting of the brake resistor used. Doing so will overheat the brake resistor.

### 8.5.4 Stall prevention operation level

Pr. 22 "stall prevention operation level"

| Setting Range    | Unit | Remarks                                                        |
|------------------|------|----------------------------------------------------------------|
| 0, 60.0 to 200.0 | %    | When 0 is set, the stall prevention function is not activated. |

When the output current reaches the Pr. 22 setting, the speed is varied with the running status to suppress the torque. The setting is based on the rated motor current.

When the stall prevention function is activated, OL appears on the screen of the FR-PU04 parameter unit. That the stall prevention function has been activated can be exported as OL signal from the terminal.

**Refer to: 8.7.2 Selection of the control circuit output terminal functions**

|             |                                                                                                                                                                                                                                                                                                                                                                                                                                                                                                                                               |
|-------------|-----------------------------------------------------------------------------------------------------------------------------------------------------------------------------------------------------------------------------------------------------------------------------------------------------------------------------------------------------------------------------------------------------------------------------------------------------------------------------------------------------------------------------------------------|
| <b>MEMO</b> | <ul style="list-style-type: none"> <li>● If the stall prevention function is activated during acceleration or deceleration, the acceleration or deceleration time [Section 8.5.2] will be longer than the setting. When the travel of a machine or the like is determined by the acceleration or deceleration time, the travel will increase due to the operation of the stall prevention function.</li> <li>● If the stall prevention function is activated during constant speed operation, the running speed may vary abruptly.</li> </ul> |
|-------------|-----------------------------------------------------------------------------------------------------------------------------------------------------------------------------------------------------------------------------------------------------------------------------------------------------------------------------------------------------------------------------------------------------------------------------------------------------------------------------------------------------------------------------------------------|

### 8.5.5 Other settings

#### Pr. 84 "rated motor speed"

---

The rated speed of the motor used with the drive unit is displayed. This parameter is for read-only and its value cannot be changed.

#### Pr. 244 "cooling fan operation selection"

---

When the drive unit has a built-in cooling fan, you can select the operation of the cooling fan.

| Setting | Operation                                                                                                                                                             |
|---------|-----------------------------------------------------------------------------------------------------------------------------------------------------------------------|
| 0       | While the drive unit power is on, the cooling fan keeps running.                                                                                                      |
| 1       | While the motor is operating, the cooling fan keeps running. While the motor is at a stop, the cooling fan is stopped according to the temperature of the drive unit. |

|             |                                                                                                                                                                                                                                                                                                                                                                                                                                                                                                                                    |
|-------------|------------------------------------------------------------------------------------------------------------------------------------------------------------------------------------------------------------------------------------------------------------------------------------------------------------------------------------------------------------------------------------------------------------------------------------------------------------------------------------------------------------------------------------|
| <b>MEMO</b> | <ul style="list-style-type: none"> <li>● If the cooling fan stops due to a failure, the "FN" alarm indication appears on the parameter unit.<br/><b>Refer to: Chapter 6, 6.1.2 Alarm function activated</b></li> <li>● That the cooling fan has stopped due to a failure can be exported as an alarm signal.<br/><b>Refer to: 8.7.2 Selection of the control circuit output terminal functions</b></li> <li>● When Pr. 244 = 1, the alarm function is activated if the fan starts running during the fan "OFF" command.</li> </ul> |
|-------------|------------------------------------------------------------------------------------------------------------------------------------------------------------------------------------------------------------------------------------------------------------------------------------------------------------------------------------------------------------------------------------------------------------------------------------------------------------------------------------------------------------------------------------|



## 8.6 Communication operation from the PU connector

|         |                                     |
|---------|-------------------------------------|
| Pr. 117 | "station number"                    |
| Pr. 118 | "communication speed"               |
| Pr. 119 | "stop bit length/data length"       |
| Pr. 120 | "parity check presence/absence"     |
| Pr. 121 | "number of communication retries"   |
| Pr. 122 | "communication check time interval" |
| Pr. 123 | "waiting time setting"              |
| Pr. 124 | "CR-LF presence/absence selection"  |

Make settings necessary for performing RS-485 communication operation from the PU connector using a personal computer or similar equipment. After you have made parameter settings, reset the CPU or switch power "OFF" once. Switching power on again makes the parameter values valid.

| Pr. | Setting Range | Unit    | Description                                                                                                                                                                                                   |
|-----|---------------|---------|---------------------------------------------------------------------------------------------------------------------------------------------------------------------------------------------------------------|
| 117 | 0 to 31       | Station | Set the station number of the drive unit.                                                                                                                                                                     |
| 118 | 48            | —       | 4800bps                                                                                                                                                                                                       |
|     | 96            | —       | 9600bps                                                                                                                                                                                                       |
|     | 192           | —       | 19200bps                                                                                                                                                                                                      |
| 119 | 0             | —       | Stop bit length 1 bit/data length 8 bits                                                                                                                                                                      |
|     | 1             | —       | Stop bit length 2 bits/data length 8 bits                                                                                                                                                                     |
|     | 10            | —       | Stop bit length 1 bit/data length 7 bits                                                                                                                                                                      |
|     | 11            | —       | Stop bit length 2 bits/data length 7 bits                                                                                                                                                                     |
| 120 | 0             | —       | None                                                                                                                                                                                                          |
|     | 1             | —       | Odd parity present                                                                                                                                                                                            |
|     | 2             | —       | Even parity present                                                                                                                                                                                           |
| 121 | 0 to 10       | Times   | Set the number of retries to be made at occurrence of a data receive error. If errors in excess of the setting occur consecutively, E. PUE appears, resulting in an alarm stop.                               |
|     | 9999          | —       | Assigning the LF signal to the control circuit output terminal allows a communication error occurrence signal to be output. Occurrence of a communication error will not cause an alarm stop. [Section 8.7.2] |
| 122 | 0             | —       | No communication. (Communication operation not performed)                                                                                                                                                     |
|     | 0.1 to 999.8  | s       | When a no-communication status time reaches the setting, E. PUE appears and an alarm stop occurs.                                                                                                             |
|     | 9999          | —       | No-communication status time check is not made.                                                                                                                                                               |
| 123 | 0 to 150      | —       | Set the waiting time from when the drive unit has received data until it gives a reply. The actual waiting time is (setting + 12)ms. (processing time)                                                        |
|     | 9999          | —       | Set the waiting time using communication data.                                                                                                                                                                |
| 124 | 0             | —       | Without CR (carriage return), LF (line feed)                                                                                                                                                                  |
|     | 1             | —       | With CR (carriage return)                                                                                                                                                                                     |
|     | 2             | —       | With CR (carriage return)/LF (line feed)                                                                                                                                                                      |

**Refer to: Chapter 6, 6.1.1 Protectire function activated**

**(1) Communication specifications**

|                           |                  |                                                    |
|---------------------------|------------------|----------------------------------------------------|
| Conforming standard       |                  | RS-485 Standard conformance                        |
| Number of units connected |                  | 1 : N (max. 32 units)                              |
| Communication speed       |                  | Selected between 19200, 9600 and 4800bps           |
| Control protocol          |                  | Asynchronous                                       |
| Communication method      |                  | Half-duplex                                        |
| Communication data        | Character system | ASCII (7 bits/8 bits) selectable                   |
|                           | Stop bit length  | Selectable between 1 bit and 2 bits.               |
|                           | Terminator       | CR/LF presence/absence selectable                  |
|                           | Parity check     | Selectable between presence (even/odd) and absence |
|                           | Sumcheck         | Presence                                           |
| Waiting time setting      |                  | Selectable between presence and absence            |

**(2) Communication operation functions**

Setting a value other than 0 in Pr. 122 enables RS-485 communication with the computer connected to the PU connector, allowing you to make operation and parameter settings.

| Setting Item             |               | Description                                                                                                                                      |
|--------------------------|---------------|--------------------------------------------------------------------------------------------------------------------------------------------------|
| Operation                | Start         | Give a forward rotation operation, reverse rotation operation or stop command.                                                                   |
|                          | Speed setting | Set the running speed.                                                                                                                           |
|                          | Monitor       | You can read the motor speed, motor current, output voltage, drive unit fault, or control circuit output terminal assignment function activated. |
|                          | Reset         | Used to reset the drive unit. A reset from the terminal RES is also valid. Reset operation is performed as set in Pr. 188 [Section 8.4].         |
| Parameter write and read |               | You can change or read each parameter value.<br>Parameter write is performed as set in Pr. 77 [Section 8.1].                                     |

Select the operation mode through serial communication.

| Operation Mode               |       |                  |       | Description                                                                                  |
|------------------------------|-------|------------------|-------|----------------------------------------------------------------------------------------------|
| Communication operation mode | Mode  | Instruction Code | Data  | Start, speed setting and other operation settings are made through serial communication.     |
|                              | Write | HFB              | H0002 |                                                                                              |
|                              | Read  | H7B              | H0002 |                                                                                              |
| External operation mode      | Mode  | Instruction Code | Data  | Start and speed setting are made using the input signals from the control circuit terminals. |
|                              | Write | HFB              | H0001 |                                                                                              |
|                              | Read  | H7B              | H0001 |                                                                                              |

The following operation is performed when a communication operation fault occurs.

| Location of Fault Occurrence                    | Operation                                                                                    |                           |
|-------------------------------------------------|----------------------------------------------------------------------------------------------|---------------------------|
|                                                 | Communication operation mode                                                                 | External operation mode   |
| Drive unit                                      | Motor operation stopped                                                                      | Motor operation stopped   |
|                                                 | Communication continued                                                                      | Communication continued   |
| Communication (Computer or communication cable) | Whether motor operation is stopped or continued depends on the Pr. 75 [Section 8.2] setting. | Motor operation continued |
|                                                 | Communication stopped                                                                        | Communication stopped     |

|               |                                                                                                                                                                                                                                                                                                                                                                                                                                                                                                                                                                                                                                                                      |
|---------------|----------------------------------------------------------------------------------------------------------------------------------------------------------------------------------------------------------------------------------------------------------------------------------------------------------------------------------------------------------------------------------------------------------------------------------------------------------------------------------------------------------------------------------------------------------------------------------------------------------------------------------------------------------------------|
| <b>NOTICE</b> | <ul style="list-style-type: none"> <li>● Communication operation is performed in response to the communication request from the personal computer. Therefore, if communication is suspended due to a communication cable break or computer failure during operation, the drive unit cannot detect a fault and stop operation. However, operation is brought to an alarm stop (E. PUE) if the time set as the communication check time interval has elapsed.<br/>To stop operation before the time set as the communication check time interval is reached, reset the CPU using the RES terminal or switch power off. The motor will then coast to a stop.</li> </ul> |
|---------------|----------------------------------------------------------------------------------------------------------------------------------------------------------------------------------------------------------------------------------------------------------------------------------------------------------------------------------------------------------------------------------------------------------------------------------------------------------------------------------------------------------------------------------------------------------------------------------------------------------------------------------------------------------------------|

### (3) Communication data and communication protocol

The following table provides the communication data and communication protocol between the computer and drive unit.

| Communication Data        | Description                                                                                                    |
|---------------------------|----------------------------------------------------------------------------------------------------------------|
| Computer sending data     | The computer gives a communication request to the drive unit in accordance with the user program               |
| Drive unit returning data | In response to the communication request from the computer, the drive unit returns data to the computer.       |
| Computer replying data    | The computer replies to the drive unit whether it could receive the drive unit returning data properly or not. |

#### ● Communication protocol in write mode (when drive unit writes data)

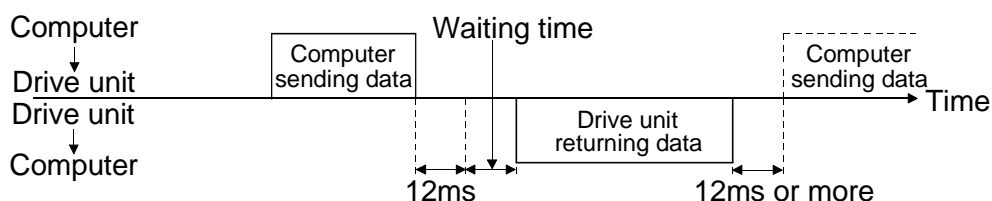

|             |                                                                                                                                                                                                                                                                                                                                                                                                               |
|-------------|---------------------------------------------------------------------------------------------------------------------------------------------------------------------------------------------------------------------------------------------------------------------------------------------------------------------------------------------------------------------------------------------------------------|
| <b>MEMO</b> | <ul style="list-style-type: none"> <li>● On detection of an error at the receipt of the data sent by the computer, the drive unit returns an error code, making the sent data invalid. Data is retransmitted (resending of data by the computer) when an error occurs. Setting of Pr. 121 allows the drive unit to come to an alarm stop if consecutive errors occur in the computer sending data.</li> </ul> |
|-------------|---------------------------------------------------------------------------------------------------------------------------------------------------------------------------------------------------------------------------------------------------------------------------------------------------------------------------------------------------------------------------------------------------------------|

#### ● Communication protocol in read mode (when data is read from drive unit)

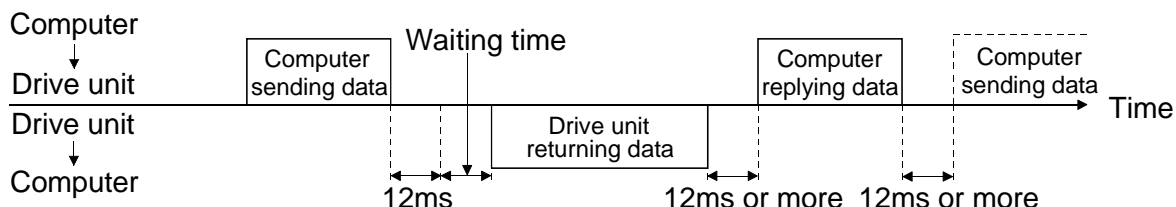

|             |                                                                                                                                                                                                                                                                                                                                                                                                                          |
|-------------|--------------------------------------------------------------------------------------------------------------------------------------------------------------------------------------------------------------------------------------------------------------------------------------------------------------------------------------------------------------------------------------------------------------------------|
| <b>MEMO</b> | <ul style="list-style-type: none"> <li>● On detection of an error at the receipt of the drive unit returning data, an error occurrence is sent using the computer replying data. In this case, the drive unit makes retry transmission (resending of drive unit returning data). Setting of Pr. 121 allows the drive unit to come to an alarm stop if consecutive errors occur in the computer replying data.</li> </ul> |
|-------------|--------------------------------------------------------------------------------------------------------------------------------------------------------------------------------------------------------------------------------------------------------------------------------------------------------------------------------------------------------------------------------------------------------------------------|

Approximately 12ms plus waiting time after the drive unit has completed receiving the data sent by the computer, the drive unit sends the drive unit returning data to the computer.

Set the waiting time in Pr. 123 to match the answerable time of the computer.

|             |                                                                                                        |
|-------------|--------------------------------------------------------------------------------------------------------|
| <b>MEMO</b> | ● The waiting time may also be set using the computer sending data. In this case, set 9999 in Pr. 123. |
|-------------|--------------------------------------------------------------------------------------------------------|

#### (4) Communication data structure

| Mode  | Communication Data        |               | Number of Characters |                |                  |          |           |          |          |          |          |    |
|-------|---------------------------|---------------|----------------------|----------------|------------------|----------|-----------|----------|----------|----------|----------|----|
|       |                           |               | 1                    | 2              | 3                | 4        | 5         | 6        | 7        | 8        | 9        | 10 |
| Write | Computer sending data     |               | ENQ                  | Station number | Instruction code |          | Data code |          | Sumcheck |          | CR<br>LF |    |
|       | Drive unit returning data | Without error | ACK                  | Station number | CR<br>LF         |          |           |          |          |          |          |    |
|       |                           | With error    | NAK                  | Station number | Error code       | CR<br>LF |           |          |          |          |          |    |
| Read  | Computer sending data     |               | ENQ                  | Station number | Instruction code |          | Sumcheck  |          | CR<br>LF |          |          |    |
|       | Drive unit sending data   | Without error | STX                  | Station number | Data code        |          | EXT       | Sumcheck |          | CR<br>LF |          |    |
|       |                           | With error    | NAX                  | Station number | Error code       | CR<br>LF |           |          |          |          |          |    |
|       | Computer replying data    | Without error | ACK                  | Station number | CR<br>LF         |          |           |          |          |          |          |    |
|       |                           | With error    | NAK                  | Station number | CR<br>LF         |          |           |          |          |          |          |    |

- The above format assumes that the data code has two characters. The number of characters in the data code changes with the communication data.
- When using the computer sending data to set the "waiting time", insert the "waiting time" data (one character) in the position next to the instruction code. Set it within the range 0 to 150ms in 10ms increments. (Example; 1: 10ms, 2: 20ms)

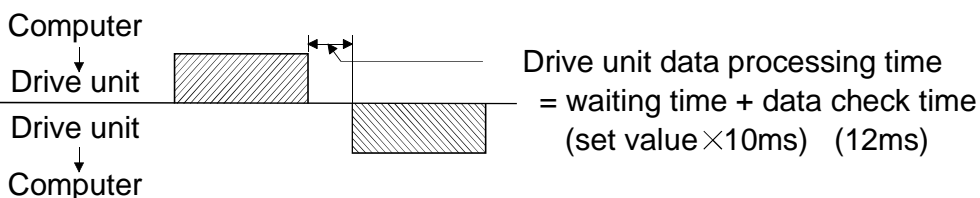

In this case, set 9999 in Pr. 123.

(Data format example)

|     |                |                  |              |           |          |       |
|-----|----------------|------------------|--------------|-----------|----------|-------|
| ENQ | Station number | Instruction code | Waiting time | Data code | Sumcheck | CR LF |
|-----|----------------|------------------|--------------|-----------|----------|-------|

**MEMO**

- The CR (carriage return) and LF (line feed) codes at the format end are automatically set by the computer when data is sent from the computer to the drive unit.

In this case, the sending data from the drive unit must also be set to match the computer data.

Select whether the CR and LF are used or not by setting the Pr. 124 value.

- Expression for calculating the communication data sending time  

$$\text{Data send time (s)} = \frac{\text{total number of bits in one character} \times \text{total number of characters}}{\text{communication speed (bps)}}$$

The total number of bits in one character is equal to the total number of following bits.

- Start bit: 1 bit
- Data: 7 or 8 bits (selected using Pr. 119)
- Stop bit: 1 or 2 bits (selected using Pr. 119)
- Parity check: 0 or 1 bit (selected using Pr. 120)

**(5) Explanation of communication data structure**

## 1) Control codes

The following table lists the ASCII codes and their definitions of the control code names which are set at the beginning, end and like of the format.

| Signal Name | ASCII Code | Description                                |
|-------------|------------|--------------------------------------------|
| STX         | H02        | Start of Text (Start of data)              |
| ETX         | H03        | End of Text (End of data)                  |
| ENQ         | H05        | Enquiry (Communication request)            |
| ACK         | H06        | Acknowledge (No data error detected)       |
| LF          | H0A        | Line Feed                                  |
| CR          | H0D        | Carriage Return                            |
| NAK         | H15        | Negative Acknowledge (Data error detected) |

## 2) Station number

Specify the station number of the drive unit used for communication with the computer.

Specify the drive unit station number within the range H00 to H1F (stations 0 to 31) in hexadecimal.

The communication data is converted into ASCII automatically.

Example: H00 (binary) → H3030 (ASCII)

## 3) Instruction codes and data codes

The instruction code and data code have been set in correspondence with the operation mode, operation or parameter write or read.

The communication data is converted into ASCII automatically.

## i) Setting the operation mode

| Setting Item   | Mode  | Instruction Code | Data Codes and Definitions                                            | Character count |
|----------------|-------|------------------|-----------------------------------------------------------------------|-----------------|
|                |       |                  |                                                                       |                 |
| Operation mode | Write | HFB              | H0001: External operation mode<br>H0002: Communication operation mode | 4               |
|                | Read  | H7B              | H0001: External operation mode<br>H0002: Communication operation mode | 4               |

ii) Setting the operation items

| Setting Item                        | Mode                                                                                                                                                                               | Instruction Code                                                                                                                                                                   | Data Codes and Definitions                                                                                                                                                                                                                                                                                                                                                                                                                                                                                                                                                          | Character count                                                                                                                                                                    |                              |                             |   |                              |                                                                                                                                                                                                 |   |   |   |    |   |
|-------------------------------------|------------------------------------------------------------------------------------------------------------------------------------------------------------------------------------|------------------------------------------------------------------------------------------------------------------------------------------------------------------------------------|-------------------------------------------------------------------------------------------------------------------------------------------------------------------------------------------------------------------------------------------------------------------------------------------------------------------------------------------------------------------------------------------------------------------------------------------------------------------------------------------------------------------------------------------------------------------------------------|------------------------------------------------------------------------------------------------------------------------------------------------------------------------------------|------------------------------|-----------------------------|---|------------------------------|-------------------------------------------------------------------------------------------------------------------------------------------------------------------------------------------------|---|---|---|----|---|
| Start                               | Write                                                                                                                                                                              | HFA                                                                                                                                                                                | H00: Stop<br>H02: Forward rotation<br>H04: Reverse rotation<br><br><div style="text-align: center;"> <table border="1" style="border-collapse: collapse;"> <tr> <td style="padding: 0 5px;">b7</td> <td style="padding: 0 5px;">0</td> <td style="padding: 0 5px;">0</td> <td style="padding: 0 5px;">0</td> <td style="padding: 0 5px;">0</td> <td style="padding: 0 5px;">0</td> <td style="padding: 0 5px;">0</td> <td style="padding: 0 5px;">1</td> <td style="padding: 0 5px;">0</td> <td style="padding: 0 5px;">b0</td> </tr> </table> <p>(For forward rotation)</p> </div> | b7                                                                                                                                                                                 | 0                            | 0                           | 0 | 0                            | 0                                                                                                                                                                                               | 0 | 1 | 0 | b0 | 2 |
| b7                                  | 0                                                                                                                                                                                  | 0                                                                                                                                                                                  | 0                                                                                                                                                                                                                                                                                                                                                                                                                                                                                                                                                                                   | 0                                                                                                                                                                                  | 0                            | 0                           | 1 | 0                            | b0                                                                                                                                                                                              |   |   |   |    |   |
| Speed setting (RAM)                 | Write                                                                                                                                                                              | HED                                                                                                                                                                                | H0000 to H1C20: 1r/min increments (hexadecimal)                                                                                                                                                                                                                                                                                                                                                                                                                                                                                                                                     | 4                                                                                                                                                                                  |                              |                             |   |                              |                                                                                                                                                                                                 |   |   |   |    |   |
|                                     | Read                                                                                                                                                                               | H6D                                                                                                                                                                                | To change the running speed consecutively, write to the drive unit RAM.                                                                                                                                                                                                                                                                                                                                                                                                                                                                                                             |                                                                                                                                                                                    |                              |                             |   |                              |                                                                                                                                                                                                 |   |   |   |    |   |
| Speed setting (E <sup>2</sup> PROM) | Write                                                                                                                                                                              | HEE                                                                                                                                                                                | H0000 to H1C20: Unit 1r/min                                                                                                                                                                                                                                                                                                                                                                                                                                                                                                                                                         | 4                                                                                                                                                                                  |                              |                             |   |                              |                                                                                                                                                                                                 |   |   |   |    |   |
|                                     | Read                                                                                                                                                                               | H6E                                                                                                                                                                                | (hexadecimal)                                                                                                                                                                                                                                                                                                                                                                                                                                                                                                                                                                       |                                                                                                                                                                                    |                              |                             |   |                              |                                                                                                                                                                                                 |   |   |   |    |   |
| Monitor                             | Speed                                                                                                                                                                              | Read                                                                                                                                                                               | H6F                                                                                                                                                                                                                                                                                                                                                                                                                                                                                                                                                                                 | H0000 to H1C20: 0 to 7200r/min                                                                                                                                                     | 4                            |                             |   |                              |                                                                                                                                                                                                 |   |   |   |    |   |
|                                     | Motor current                                                                                                                                                                      | Read                                                                                                                                                                               | H70                                                                                                                                                                                                                                                                                                                                                                                                                                                                                                                                                                                 | H0000 to HC350: 0 to 500.00A                                                                                                                                                       | 4                            |                             |   |                              |                                                                                                                                                                                                 |   |   |   |    |   |
|                                     | Output voltage                                                                                                                                                                     | Read                                                                                                                                                                               | H71                                                                                                                                                                                                                                                                                                                                                                                                                                                                                                                                                                                 | H0000 to H0FA0: 0 to 400.0V                                                                                                                                                        | 4                            |                             |   |                              |                                                                                                                                                                                                 |   |   |   |    |   |
|                                     | Alarm code                                                                                                                                                                         | Read                                                                                                                                                                               | H74                                                                                                                                                                                                                                                                                                                                                                                                                                                                                                                                                                                 | <table border="0"> <tr> <td style="padding-right: 10px;">H** **</td> <td>└ Latest alarm</td> </tr> <tr> <td></td> <td>└ Previous alarm</td> </tr> </table>                         | H** **                       | └ Latest alarm              |   | └ Previous alarm             | H00: No alarm<br>H10: 0C1<br>H11: 0C2<br>H12: 0C3<br>H20: 0V1<br>H21: 0V2<br>H22: 0V3<br>H30: THT<br>H31: THM<br>H40: FIN<br>H51: UVT<br>H60: OLT<br>H70: BE<br>HB0: PE<br>HB1: PUE<br>HFF: E15 | 4 |   |   |    |   |
|                                     |                                                                                                                                                                                    |                                                                                                                                                                                    | H** **                                                                                                                                                                                                                                                                                                                                                                                                                                                                                                                                                                              | └ Latest alarm                                                                                                                                                                     |                              |                             |   |                              |                                                                                                                                                                                                 |   |   |   |    |   |
|                                     |                                                                                                                                                                                    |                                                                                                                                                                                    |                                                                                                                                                                                                                                                                                                                                                                                                                                                                                                                                                                                     | └ Previous alarm                                                                                                                                                                   |                              |                             |   |                              |                                                                                                                                                                                                 |   |   |   |    |   |
|                                     |                                                                                                                                                                                    |                                                                                                                                                                                    | H75                                                                                                                                                                                                                                                                                                                                                                                                                                                                                                                                                                                 | <table border="0"> <tr> <td style="padding-right: 10px;">H** **</td> <td>└ Alarm two times prior to</td> </tr> <tr> <td></td> <td>└ Alarm three times prior to</td> </tr> </table> | H** **                       | └ Alarm two times prior to  |   | └ Alarm three times prior to |                                                                                                                                                                                                 | 4 |   |   |    |   |
|                                     | H** **                                                                                                                                                                             | └ Alarm two times prior to                                                                                                                                                         |                                                                                                                                                                                                                                                                                                                                                                                                                                                                                                                                                                                     |                                                                                                                                                                                    |                              |                             |   |                              |                                                                                                                                                                                                 |   |   |   |    |   |
|                                     |                                                                                                                                                                                    | └ Alarm three times prior to                                                                                                                                                       |                                                                                                                                                                                                                                                                                                                                                                                                                                                                                                                                                                                     |                                                                                                                                                                                    |                              |                             |   |                              |                                                                                                                                                                                                 |   |   |   |    |   |
|                                     | H76                                                                                                                                                                                | <table border="0"> <tr> <td style="padding-right: 10px;">H** **</td> <td>└ Alarm four times prior to</td> </tr> <tr> <td></td> <td>└ Alarm five times prior to</td> </tr> </table> | H** **                                                                                                                                                                                                                                                                                                                                                                                                                                                                                                                                                                              | └ Alarm four times prior to                                                                                                                                                        |                              | └ Alarm five times prior to |   | 4                            |                                                                                                                                                                                                 |   |   |   |    |   |
| H** **                              | └ Alarm four times prior to                                                                                                                                                        |                                                                                                                                                                                    |                                                                                                                                                                                                                                                                                                                                                                                                                                                                                                                                                                                     |                                                                                                                                                                                    |                              |                             |   |                              |                                                                                                                                                                                                 |   |   |   |    |   |
|                                     | └ Alarm five times prior to                                                                                                                                                        |                                                                                                                                                                                    |                                                                                                                                                                                                                                                                                                                                                                                                                                                                                                                                                                                     |                                                                                                                                                                                    |                              |                             |   |                              |                                                                                                                                                                                                 |   |   |   |    |   |
| H77                                 | <table border="0"> <tr> <td style="padding-right: 10px;">H** **</td> <td>└ Alarm six times prior to</td> </tr> <tr> <td></td> <td>└ Alarm seven times prior to</td> </tr> </table> | H** **                                                                                                                                                                             | └ Alarm six times prior to                                                                                                                                                                                                                                                                                                                                                                                                                                                                                                                                                          |                                                                                                                                                                                    | └ Alarm seven times prior to |                             | 4 |                              |                                                                                                                                                                                                 |   |   |   |    |   |
| H** **                              | └ Alarm six times prior to                                                                                                                                                         |                                                                                                                                                                                    |                                                                                                                                                                                                                                                                                                                                                                                                                                                                                                                                                                                     |                                                                                                                                                                                    |                              |                             |   |                              |                                                                                                                                                                                                 |   |   |   |    |   |
|                                     | └ Alarm seven times prior to                                                                                                                                                       |                                                                                                                                                                                    |                                                                                                                                                                                                                                                                                                                                                                                                                                                                                                                                                                                     |                                                                                                                                                                                    |                              |                             |   |                              |                                                                                                                                                                                                 |   |   |   |    |   |
| Drive unit status                   | Read                                                                                                                                                                               | H7A                                                                                                                                                                                | H01: Function assigned to RUN terminal is activated<br>H02: During forward rotation (STF terminal signal ON)<br>H04: During reverse rotation (STR terminal signal ON)<br>H40: Function assigned to FU terminal is activated<br>H80: Alarm output is provided                                                                                                                                                                                                                                                                                                                        | 2                                                                                                                                                                                  |                              |                             |   |                              |                                                                                                                                                                                                 |   |   |   |    |   |
| Reset                               | Write                                                                                                                                                                              | HFD                                                                                                                                                                                | H9696: The drive unit is reset. In this case, the drive unit returning data is not returned. After a reset, wait for more than 100ms and send the computer sending data.                                                                                                                                                                                                                                                                                                                                                                                                            | 4                                                                                                                                                                                  |                              |                             |   |                              |                                                                                                                                                                                                 |   |   |   |    |   |
| Alarm code batch-clear              | Write                                                                                                                                                                              | HF4                                                                                                                                                                                | H9696: Eight alarms stored as a history are all cleared.                                                                                                                                                                                                                                                                                                                                                                                                                                                                                                                            | 4                                                                                                                                                                                  |                              |                             |   |                              |                                                                                                                                                                                                 |   |   |   |    |   |

## iii) Parameter write and read

Parameter write and read require the setting of the extension codes given in Appendix 1 Parameter List (Numerical Order). After setting the extension code, set the instruction code given in Appendix 1 Parameter List (Numerical Order) and perform write or read.

This function is performed as set in Pr. 77.

| Setting Item           | Mode  | Instruction Code                    | Data Codes and Definitions                                                                                                                                                                                                                                                           | Character count |
|------------------------|-------|-------------------------------------|--------------------------------------------------------------------------------------------------------------------------------------------------------------------------------------------------------------------------------------------------------------------------------------|-----------------|
|                        |       |                                     |                                                                                                                                                                                                                                                                                      |                 |
| Extension code setting | Write | HFF                                 | H00: Parameter of extension code 0 can be accessed for read/write.<br>H01: Parameter of extension code 1 can be accessed for read/write.<br>H02: Parameter of extension code 2 can be accessed for read/write.<br>H09: Parameter of extension code 9 can be accessed for read/write. | 2               |
|                        | Read  | H7F                                 |                                                                                                                                                                                                                                                                                      |                 |
| Parameter              | Write | Refer to Appendix 1 Parameter List. | H0000 to HFFFF: Parameter settings (hexadecimal)                                                                                                                                                                                                                                     | 4               |
|                        | Read  |                                     |                                                                                                                                                                                                                                                                                      |                 |

|             |                                                                                                                                                |
|-------------|------------------------------------------------------------------------------------------------------------------------------------------------|
| <b>MEMO</b> | ● Once written, the setting of the HFF instruction code is held, but is cleared to "0" when the drive unit is reset or all clear is performed. |
|-------------|------------------------------------------------------------------------------------------------------------------------------------------------|

When converting a value having a decimal place, e.g. parameter setting range, into a data code, make conversion in the setting range whose decimal place has been carried. Use "HFFFF" with the value "9999" which means no function.

(Example)

| Parameter | Setting Range (Parameter list) | Setting Range (Communication) | Data Code                        |
|-----------|--------------------------------|-------------------------------|----------------------------------|
| Pr. 7     | 0.0 to 60                      | 0 to 6000                     | H0000 to H1770                   |
| Pr. 24    | 0 to 7200<br>9999              | 0 to 7200<br>9999             | H0000 to H1C20<br>HFFFF          |
| Pr. 122   | 0<br>0.1 to 999.8<br>9999      | 0<br>1 to 9998<br>9999        | H0000<br>H0001 to H270E<br>HFFFF |
| Pr. 124   | 0<br>1<br>2                    | 0<br>1<br>2                   | H0001<br>H0002<br>H0003          |



Set the bias and gains in Pr. 902 to 905 [Section 8.3.1].

| Setting Item | Mode  | Instruction Code | Data Codes and Definitions                                     | Character count |
|--------------|-------|------------------|----------------------------------------------------------------|-----------------|
|              |       |                  |                                                                |                 |
| Bias/gain    | Write | HEC              | H00: Bias/gain                                                 | 2               |
|              | Read  | H6C              | H01: Any analog A/D value<br>H02: Analog A/D value of terminal |                 |

|             |                                                                                                                                                |
|-------------|------------------------------------------------------------------------------------------------------------------------------------------------|
| <b>MEMO</b> | ● Once written, the setting of the HEC instruction code is held, but is cleared to "0" when the drive unit is reset or all clear is performed. |
|-------------|------------------------------------------------------------------------------------------------------------------------------------------------|

Clear the parameters.

| Setting Item    | Mode  | Instruction Code | Data Codes and Definitions                                                                                                                                                                                                                                                                                                                                                                                                                                             | Character count |
|-----------------|-------|------------------|------------------------------------------------------------------------------------------------------------------------------------------------------------------------------------------------------------------------------------------------------------------------------------------------------------------------------------------------------------------------------------------------------------------------------------------------------------------------|-----------------|
|                 |       |                  |                                                                                                                                                                                                                                                                                                                                                                                                                                                                        |                 |
| Parameter clear | Write | HFC              | <p>H5A5A: The parameter settings other than the following are initialized to the factory settings.</p> <ul style="list-style-type: none"> <li>• Communication parameters (Pr. 117 to 124)</li> <li>• Calibration parameter (Pr. 900 [Section 8.7.5], Pr. 902, Pr. 903 [Section 8.3.1])</li> <li>• Control parameters</li> <li>• Pr. 75 [Section 8.2], Pr. 188 [Section 8.4]</li> </ul> <p>Also use the data code H9696 to initialize the communication parameters.</p> | 4               |
| All clear       | Write | HFC              | <p>H55AA: The parameter settings other than the following are initialized to the factory settings.</p> <ul style="list-style-type: none"> <li>• Communication parameters (Pr. 117 to 124)</li> <li>• Pr. 75, Pr. 188</li> </ul> <p>Also use the data code H9966 to initialize the communication parameters.</p>                                                                                                                                                        | 4               |

## 4) Sumcheck

As a sumcheck value, set the lower 1 byte (8 bits) of the sum derived from ASCII data (station number, instruction code, waiting time, data code) except the control code. The communication data is converted into ASCII automatically.

|               |       |                   |                     |                 |                 |           |
|---------------|-------|-------------------|---------------------|-----------------|-----------------|-----------|
| Data →        | ENQ   | Station<br>Number | Instruction<br>Code | Waiting<br>Time | Data Code       | Sumcheck  |
| Binary code → | —     | 0 1               | E 1                 | 1               | 0 7 A D         | F 4       |
| ASCII code →  | (H05) | H30 H31           | H45 H31             | H31             | H30 H37 H41 H44 | (H46 H34) |

Sumcheck value calculation:  $H30+31+45+31+31+30+37+41+44=H1F4$

## 5) Error codes

When the data received by the drive unit is in error, the error code is returned to the computer. The definitions of the error codes are as follows.

| Error Code | Error Item             | Error Definition                                                                                                                                             | Drive Unit Operation                                                                                                                                                                                                                     |
|------------|------------------------|--------------------------------------------------------------------------------------------------------------------------------------------------------------|------------------------------------------------------------------------------------------------------------------------------------------------------------------------------------------------------------------------------------------|
| H0         | Computer NAK error     | The number of errors consecutively detected in communication request data from the computer is greater than the permissible number of retries.               | If errors occur consecutively more than the permissible number of communication retries (Pr. 121 setting), the drive unit displays E. PUE and comes to an alarm stop.<br><b>Refer to: Chapter 6, 6.1.1 Protective function activated</b> |
| H1         | Parity error           | The parity check result does not match the specified parity.                                                                                                 |                                                                                                                                                                                                                                          |
| H2         | Sumcheck error         | The sumcheck value in the computer does not match that of the data received by the drive unit.                                                               |                                                                                                                                                                                                                                          |
| H3         | Protocol error         | Data received by the drive unit is in the wrong protocol, data receive is not completed within the given time, or CR and LF are not as set in the parameter. |                                                                                                                                                                                                                                          |
| H4         | Framing error          | The stop bit length differs from the initial setting.                                                                                                        |                                                                                                                                                                                                                                          |
| H5         | Overrun                | New data has been sent by the computer before the drive unit completes receiving the preceding data.                                                         |                                                                                                                                                                                                                                          |
| H7         | Character error        | The character received is invalid (other than 0 to 9, A to F, control code).                                                                                 | The receive data is made invalid and the drive unit continues operation.                                                                                                                                                                 |
| HA         | Mode error             | Parameter write was attempted in other than the computer link operation mode or during drive unit operation, for example.                                    |                                                                                                                                                                                                                                          |
| HB         | Instruction code error | The specified command does not exist.                                                                                                                        |                                                                                                                                                                                                                                          |
| HC         | Data range error       | Invalid data has been specified for parameter write, running speed write, etc.                                                                               |                                                                                                                                                                                                                                          |

**(6) Program example (Switching the operation mode to communication operation)**

|                                                                                                                                                                                                                                                                                                                                                                                                                                 |                                                                                                                                                                                                                                                                                                                                                                                                                                                                                                                                                                                                                                                                                                                                                                                                                                                                                                                                                                              |
|---------------------------------------------------------------------------------------------------------------------------------------------------------------------------------------------------------------------------------------------------------------------------------------------------------------------------------------------------------------------------------------------------------------------------------|------------------------------------------------------------------------------------------------------------------------------------------------------------------------------------------------------------------------------------------------------------------------------------------------------------------------------------------------------------------------------------------------------------------------------------------------------------------------------------------------------------------------------------------------------------------------------------------------------------------------------------------------------------------------------------------------------------------------------------------------------------------------------------------------------------------------------------------------------------------------------------------------------------------------------------------------------------------------------|
| <pre> 10 OPEN "COM1 : 9600,E,8,2,HD" AS #1 20 COMST1,1,1:COMST1,2,1  30 ON COM(1)GOSUB *REC 40 COM(1)ON 50 D\$= "01FB10002" 60 S=0 70 FOR I=1 TO LEN(D\$) 80 A\$=MID\$(D\$,I,1) 90 A=ASC(A\$) 100 S=S+A 110 NEXTI 120 D\$=CHR\$(&amp;H5)+D\$+RIGHT\$(HEX\$(S),2) 130 PRINT#1,D\$ 140 GOTO 50  1000 *REC 1010 IF LOC(1)=0 THEN RETURN 1020 PRINT "RECEIVE DATA" 1030 PRINT INPUT\$(LOC(1),#1) 1040 RETURN                 </pre> | <div style="border: 1px dashed black; border-radius: 10px; padding: 2px; display: inline-block;">Initial setting of input file</div><br>: Communication file opening<br>: Circuit control signal (RS (ON in data-receivable status), ER (unit ready signal)) ON/OFF setting<br><br>: Interrupt definition at data receive<br>: Interrupt enable<br><div style="border: 1px dashed black; border-radius: 10px; padding: 2px; display: inline-block;">Transmission data setting</div><br><br><div style="border: 1px dashed black; border-radius: 10px; padding: 2px; display: inline-block;">Sum code calculation</div><br><br>: Addition of control and sum codes<br><div style="border: 1px dashed black; border-radius: 10px; padding: 2px; display: inline-block;">Data transmission</div><br><br><div style="border: 1px dashed black; border-radius: 10px; padding: 2px; display: inline-block;">Interrupt data receive</div><br>: Interrupt occurrence at data receive |
|---------------------------------------------------------------------------------------------------------------------------------------------------------------------------------------------------------------------------------------------------------------------------------------------------------------------------------------------------------------------------------------------------------------------------------|------------------------------------------------------------------------------------------------------------------------------------------------------------------------------------------------------------------------------------------------------------------------------------------------------------------------------------------------------------------------------------------------------------------------------------------------------------------------------------------------------------------------------------------------------------------------------------------------------------------------------------------------------------------------------------------------------------------------------------------------------------------------------------------------------------------------------------------------------------------------------------------------------------------------------------------------------------------------------|

General flowchart

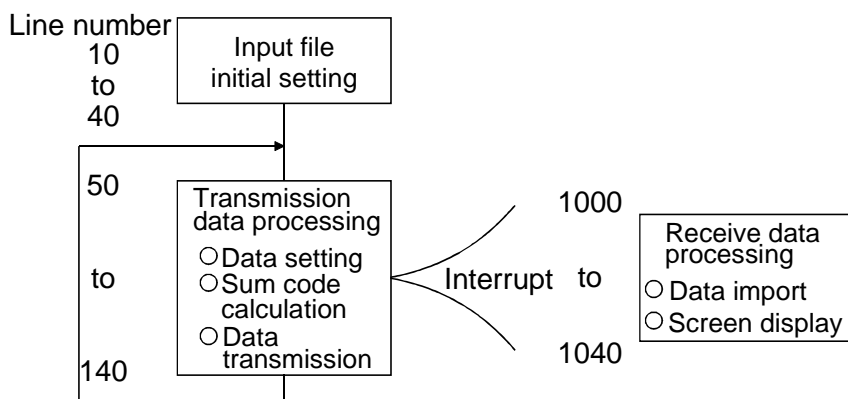

|               |                                                                                                                                                                                                                                                                                                                                                                                                                                                                                                |
|---------------|------------------------------------------------------------------------------------------------------------------------------------------------------------------------------------------------------------------------------------------------------------------------------------------------------------------------------------------------------------------------------------------------------------------------------------------------------------------------------------------------|
| <b>NOTICE</b> | <ul style="list-style-type: none"> <li>● The drive unit does not accept data from the computer if it is in error. Hence, always insert a data error retry program in the user program.</li> <li>● Since the communication of any data, e.g. run command, monitor, is started from the computer, the drive unit will not return data without the computer's command. For monitoring, therefore, design the program to cause the computer to provide a data read request as required.</li> </ul> |
|---------------|------------------------------------------------------------------------------------------------------------------------------------------------------------------------------------------------------------------------------------------------------------------------------------------------------------------------------------------------------------------------------------------------------------------------------------------------------------------------------------------------|

## 8.7 Monitoring of Operation Status

### 8.7.1 Selection of parameter unit display data

#### Pr. 37 "speed unit switch-over 1"

Change the display unit of the FR-PU04 parameter unit.

| Setting Range | Function                                                                                                                                                                                                                                              |
|---------------|-------------------------------------------------------------------------------------------------------------------------------------------------------------------------------------------------------------------------------------------------------|
| 0             | The motor speed is displayed. The unit is r/min.                                                                                                                                                                                                      |
| 1 to 9998     | By setting a value corresponding to the rated speed, a machine operation amount equivalent can be displayed. At the setting of "10", 10 appears when the motor reaches the rated speed and "3" appears when the motor reaches 1/3 of the rated speed. |

|             |                                                                                                                     |
|-------------|---------------------------------------------------------------------------------------------------------------------|
| <b>MEMO</b> | ● Changing the speed unit switch-over setting also changes the units of the other speed-related parameter settings. |
|-------------|---------------------------------------------------------------------------------------------------------------------|

#### Pr. 144 "speed unit switch-over 2"

Set this parameter to show the display unit of the FR-PU04 parameter unit as an output frequency.

| Setting Range | Function                                                                              |
|---------------|---------------------------------------------------------------------------------------|
| 0             | The Pr. 37 setting is enabled.                                                        |
| 1             | The Pr. 37 setting is disabled and the output frequency is displayed. The unit is Hz. |

#### Pr. 52 "main display screen data selection"

You can select the display data of the main display screen of the parameter unit.

| Setting | Display Data                                                 | Unit      |
|---------|--------------------------------------------------------------|-----------|
| 0       | Motor speed, Output frequency (Note)                         | r/min, Hz |
|         | Motor current                                                | A         |
|         | Output voltage                                               | V         |
|         | Alarm indication                                             | —         |
| 100     | Motor speed (during operation)<br>Preset speed (during stop) | r/min     |
|         | Motor current                                                | A         |
|         | Output voltage                                               | V         |
|         | Alarm indication                                             | —         |
| 5       | Preset speed                                                 | r/min     |
| 6       | Motor speed                                                  | r/min     |

Note: Setting "1" in Pr. 144 changes the display data to output frequency.

## 8.7.2 Selection of the control circuit output terminal functions

**Pr. 190 "RUN terminal function selection"**

**Pr. 194 "FU terminal function selection"**

You can select/change the functions of the control circuit output terminals. At the initial values, the terminal names and signal names match.

| Setting | Signal Name | Operation                                                                                                                                                                |
|---------|-------------|--------------------------------------------------------------------------------------------------------------------------------------------------------------------------|
| 0       | RUN         | "ON" during motor operation, "OFF" during voltage braking operation or stop.                                                                                             |
| 3       | OL          | Turns "ON" when overload is Pr. 22 setting or higher.<br><b>Refer to: 8.5.4 Stall prevention operation level</b>                                                         |
| 4       | FU          | Turns "ON" at the preset speed or more.<br><b>Refer to: 8.7.3 Detection of running speed</b>                                                                             |
| 12      | Y12         | "ON" at the preset output current or higher.<br><b>Refer to: 8.7.4 Detection of output current</b>                                                                       |
| 21      | UVT         | Turns "ON" when AC input power supply voltage is insufficient.<br><b>Refer to: 6.1.1 Protective function actived (Undervoltage)</b>                                      |
| 25      | FAN         | Turns "ON" only when the cooling fan fails.                                                                                                                              |
| 98      | LF          | Turns "ON" at a fan failure or communication error alarm.<br><b>Refer to: 8.5.5 Other settings</b><br><b>Refer to: 8.6 Communication operation from the PU connector</b> |
| 99      | ABC         | Turns "ON" when the protective function is activated.<br><b>Refer to: Chapter 6 Troubleshooting</b>                                                                      |
| 9999    | —           | No function                                                                                                                                                              |

## 8.7.3 Detection of running speed

**Pr. 42 "speed detection"**

**Pr. 43 "speed detection for reverse rotation"**

| Pr. | Setting Range | Unit  | Signal |
|-----|---------------|-------|--------|
| 42  | 0 to 7200     | r/min | FU     |
| 43  | 0 to 7200     | r/min | FU     |
|     | 9999          | —     | —      |

Once the motor speed has reached or exceeded the speed set in the corresponding parameter, it is exported from the control circuit output terminals where the FU signal has been assigned.

Pr. 43 is valid for only the operation performed using the reverse rotation signal (terminal STR or **REV** key).

Setting the Pr. 43 value makes the Pr. 42 setting invalid for reverse rotation signal operation so that you can separate detection between forward rotation operation and reverse rotation operation.

Setting "9999" in Pr. 43 provides the same function as set in Pr. 42.

**Refer to: 8.7.2 Selection for the control circuit output terminal functions**

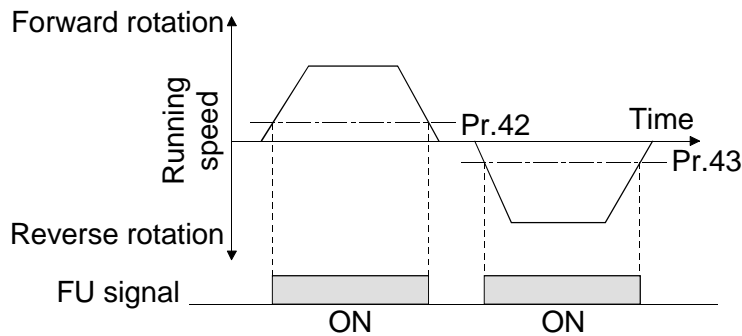

### 8.7.4 Detection of output current

**Pr. 150** "output current detection level"

**Pr. 151** "output current detection time"

| Pr. | Setting Range | Unit |
|-----|---------------|------|
| 150 | 0.0 to 200.0  | %    |
| 151 | 0.0 to 10.0   | s    |

If the motor current remains higher than the Pr. 150 setting for longer than the time set in Pr. 151, the terminal where the assigned Y12 signal turns "ON". The Pr. 150 value is based on the rated motor current.

Use any of Pr. 190, Pr. 194 [Section 8.7.2] to assign the terminal used for Y12 signal output.

Once turned on, the Y12 signal remains on for at least 100ms.

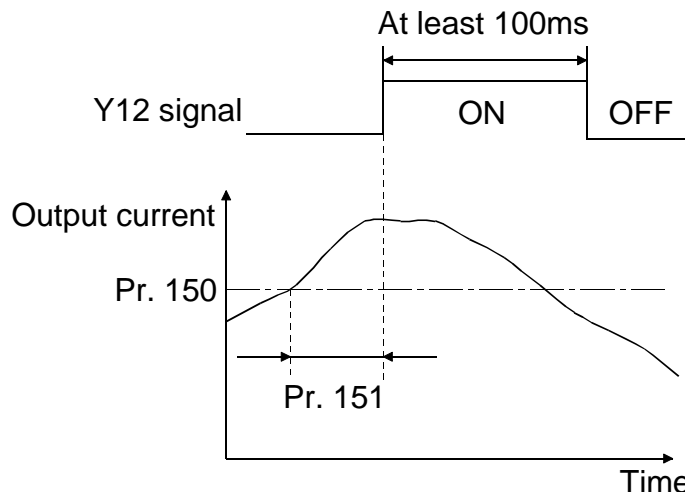

## 8.7.5 Selection of the instrument connection terminal functions

### Pr. 54 "FM terminal function selection"

You can select the signals output to the FM terminal designed for instrument connection.

| Setting | Display Data  | Unit  | Full-Scale          |
|---------|---------------|-------|---------------------|
| 1       | Motor speed   | r/min | Value set in Pr. 55 |
| 2       | Motor current | A     | Value set in Pr. 56 |
| 5       | Preset speed  | r/min | Value set in Pr. 55 |

|             |                                                                                                                                                                                                                   |
|-------------|-------------------------------------------------------------------------------------------------------------------------------------------------------------------------------------------------------------------|
| <b>MEMO</b> | <ul style="list-style-type: none"> <li>● The maximum number of pulses of the terminal FM is 2400 pulses/s.</li> <li>● The output signals from the terminal FM is updated at intervals of several 10ms.</li> </ul> |
|-------------|-------------------------------------------------------------------------------------------------------------------------------------------------------------------------------------------------------------------|

### Pr. 55 "speed monitoring reference"

### Pr. 56 "current monitoring reference"

The terminal FM outputs a 1440 pulse/s signal at the value set in Pr. 55 or 56.

| Pr. | Setting Range  | Unit  |
|-----|----------------|-------|
| 55  | 0 to 7200      | r/min |
| 56  | 0.00 to 500.00 | A     |

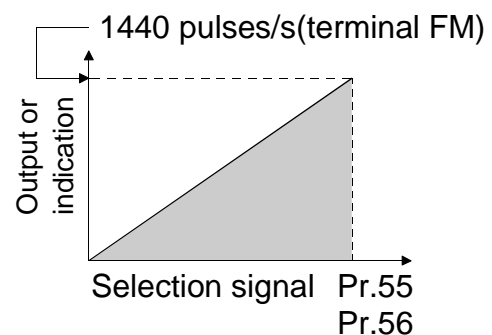

### Pr. 900 "FM terminal calibration"

Using the parameter unit, you can calibrate the full scale of a meter connected to the FM instrument connection terminal.

The terminal FM outputs a 1mADC current at the value set in Pr. 55 or 56. When the full scale of the meter used must be calibrated, it can be adjusted using Pr. 900.

For the calibration procedure, refer to the instruction manual of the parameter unit.

**APPENDIX 1 PARAMETER LIST (NUMERICAL ORDER)**

| No. | Name                                       | Setting Range        | Initial Value | Customer Setting | Instruction Code |       | Data      | Refer to |
|-----|--------------------------------------------|----------------------|---------------|------------------|------------------|-------|-----------|----------|
|     |                                            |                      |               |                  | read             | Write | Extension |          |
| 1   | Maximum speed                              | 0 to 7200r/min       | 7200          |                  | 01               | 81    | 0         | 8-6      |
| 2   | Minimum speed                              | 0 to 7200r/min       | 0             |                  | 02               | 82    | 0         |          |
| 4   | Three-speed setting (high speed)           | 0 to 7200r/min       | 7200          |                  | 04               | 84    | 0         | 8-4      |
| 5   | Three-speed setting (middle speed)         | 0 to 7200r/min       | 3600          |                  | 05               | 85    | 0         |          |
| 6   | Three-speed setting (low speed)            | 0 to 7200r/min       | 1200          |                  | 06               | 86    | 0         |          |
| 7   | Acceleration time                          | 0.00 to 60.00s       | 40            |                  | 07               | 87    | 0         | 8-8      |
| 8   | Deceleration time                          | 0.00 to 60.00s       | 40            |                  | 08               | 88    | 0         |          |
| 20  | Acceleration/ deceleration reference speed | 1 to 7200r/min       | 7200          |                  | 14               | 94    | 0         |          |
| 22  | Stall prevention operation level           | 0,60.0 to 200.0%     | 150           |                  | 16               | 96    | 0         | 8-9      |
| 24  | Multi-speed setting (speed 4)              | 0 to 7200r/min, 9999 | 9999          |                  | 18               | 98    | 0         | 8-4      |
| 25  | Multi-speed setting (speed 5)              | 0 to 7200r/min, 9999 | 9999          |                  | 19               | 99    | 0         |          |
| 26  | Multi-speed setting (speed 6)              | 0 to 7200r/min, 9999 | 9999          |                  | 1A               | 9A    | 0         |          |
| 27  | Multi-speed setting (speed 7)              | 0 to 7200r/min, 9999 | 9999          |                  | 1B               | 9B    | 0         |          |
| 30  | Regenerative brake option selection        | 0, 1                 | 1             |                  | 1E               | 9E    | 0         | 8-9      |
| 31  | Speed command jump 1A                      | 0 to 7200r/min, 9999 | 9999          |                  | 1F               | 9F    | 0         | 8-7      |
| 32  | Speed command jump 1B                      | 0 to 7200r/min, 9999 | 9999          |                  | 20               | A0    | 0         |          |
| 33  | Speed command jump 2A                      | 0 to 7200r/min, 9999 | 9999          |                  | 21               | A1    | 0         |          |
| 34  | Speed command jump 2B                      | 0 to 7200r/min, 9999 | 9999          |                  | 22               | A2    | 0         |          |
| 35  | Speed command jump 3A                      | 0 to 7200r/min, 9999 | 9999          |                  | 23               | A3    | 0         |          |
| 36  | Speed command jump 3B                      | 0 to 7200r/min, 9999 | 9999          |                  | 24               | A4    | 0         |          |
| 37  | Speed unit switch-over 1                   | 0 to 9998            | 0             |                  | 25               | A5    | 0         | 8-22     |



**APPENDIX 1 PARAMETER LIST (NUMERICAL ORDER)**

| No. | Name                                        | Setting Range                | Initial Value       | Customer Setting | Instruction Code |       | Data      | Refer to |
|-----|---------------------------------------------|------------------------------|---------------------|------------------|------------------|-------|-----------|----------|
|     |                                             |                              |                     |                  | read             | Write | Extension |          |
| 42  | Speed detection                             | 0 to 7200r/min               | 720                 |                  | 2A               | AA    | 0         | 8-23     |
| 43  | Speed detection for reverse rotation        | 0 to 7200r/min, 9999         | 9999                |                  | 2B               | AB    | 0         |          |
| 52  | Main display screen data selection          | Refer to manual description. | 0                   |                  | 34               | B4    | 0         | 8-22     |
| 54  | FM terminal function selection              | Refer to manual description. | 1                   |                  | 36               | B6    | 0         | 8-25     |
| 55  | Speed monitoring reference                  | 0 to 7200r/min               | 7200                |                  | 37               | B7    | 0         |          |
| 56  | Current monitoring reference                | 0.00 to 500.00A              | Rated motor current |                  | 38               | B8    | 0         |          |
| 70  | Regenerative brake duty                     | 0.0 to 15.0%                 | 10                  |                  | 46               | C6    | 0         | 8-9      |
| 73  | Speed command range selection               | 0, 1                         | 0                   |                  | 49               | C9    | 0         | 8-3      |
| 74  | Filter time constant                        | 0 to 8                       | 1                   |                  | 4A               | CA    | 0         |          |
| 75  | Disconnected PU detection/PU stop selection | 0 to 3                       | 0                   |                  | 4B               | CB    | 0         | 8-2      |
| 77  | Parameter write disable selection           | 0, 1, 2                      | 0                   |                  | 4D               | CD    | 0         | 8-1      |
| 78  | Reverse rotation prevention selection       | 0, 1, 2                      | 1                   |                  | 4E               | CE    | 0         | 8-7      |
| 84  | Rated motor speed                           | Read-only                    |                     |                  | 54               | —     | 0         | 8-10     |
| 117 | Station number                              | 0 to 31                      | 0                   |                  | 11               | 91    | 1         | 8-11     |
| 118 | Communication speed                         | 48, 96, 192                  | 192                 |                  | 12               | 92    | 1         |          |
| 119 | Stop bit length/data length                 | 0, 1, 10, 11                 | 1                   |                  | 13               | 93    | 1         |          |
| 120 | Parity check presence /absence              | 0, 1, 2                      | 2                   |                  | 14               | 94    | 1         |          |

**APPENDIX 1 PARAMETER LIST (NUMERICAL ORDER)**

| No. | Name                                  | Setting Range                | Initial Value                   | Customer Setting  | Instruction Code |       | Data      | Refer to |     |
|-----|---------------------------------------|------------------------------|---------------------------------|-------------------|------------------|-------|-----------|----------|-----|
|     |                                       |                              |                                 |                   | read             | Write | Extension |          |     |
| 121 | Number of communication retries       | 0 to 10, 9999                | 1                               |                   | 15               | 95    | 1         | 8-11     |     |
| 122 | Communication check time interval     | 0, 0.1 to 999.8, 9999        | 0                               |                   | 16               | 96    | 1         |          |     |
| 123 | Waiting time setting                  | 0 to 150, 9999               | 9999                            |                   | 17               | 97    | 1         |          |     |
| 124 | CR-LF presence /absence selection     | 0, 1, 2                      | 1                               |                   | 18               | 98    | 1         |          |     |
| 144 | Speed unit switch-over 2              | 0, 1                         | 0                               |                   | 2C               | AC    | 1         | 8-22     |     |
| 150 | Output current detection level        | 0.0 to 200.0%                | 150                             |                   | 32               | B2    | 1         | 8-24     |     |
| 151 | Output current detection time         | 0.0 to 10.0s                 | 0                               |                   | 33               | B3    | 1         |          |     |
| 188 | RES terminal operation selection      | 0, 1                         | 0                               |                   | 1C               | 9C    | 2         | 8-5      |     |
| 189 | STF, STR terminal operation selection | 0, 1                         | 0                               |                   | 1D               | 9D    | 2         |          |     |
| 190 | RUN terminal function selection       | Refer to manual description. | 0                               |                   | 1E               | 9E    | 2         | 8-23     |     |
| 194 | FU terminal function selection        | Refer to manual description. | 4                               |                   | 22               | A2    | 2         |          |     |
| 244 | Cooling fan operation selection       | 0, 1                         | 0                               |                   | 34               | B4    | 2         | 8-10     |     |
| 900 | Calibration parameters                | FM terminal calibration      | —                               |                   | 5C               | DC    | 1         | 8-25     |     |
| 902 |                                       | Speed setting voltage bias   | 0.0 to 300.0%<br>0 to 7200r/min | Approx.<br>0<br>0 |                  | 5E    | DE        | 1        | 8-3 |
| 903 |                                       | Speed setting voltage gain   | 0.0 to 300.0%<br>1 to 7200r/min | 100<br>7200       |                  | 5F    | DF        | 1        |     |

## REVISIONS

\*The manual number is given on the bottom left of the back cover.

| Print Date | *Manual Number   | Revision      |
|------------|------------------|---------------|
| Jan., 2002 | IB(NA)-0600103-A | First edition |
|            |                  |               |