



# INVERTER

Plug-in option

## FR-A7NP E kit

### INSTRUCTION MANUAL

---

***PROFIBUS-DP***  
***communication function***

---

PRE-OPERATION INSTRUCTIONS

1

INSTALLATION

2

WIRING

3

INVERTER SETTING

4

FUNCTIONS

5

PROFIBUS DEVICE DATA

6

PPO TYPE SUPPORT SPECIFICATION

7

PPO TYPE NON-SUPPORT SPECIFICATION

8

TROUBLESHOOTING

9

Thank you for choosing this Mitsubishi Inverter plug-in option. This Instruction Manual gives handling information and precautions for use of this equipment. Incorrect handling might cause an unexpected fault. Before using the equipment, please read this manual carefully to use the equipment to its optimum. Please forward this manual to the end user.

## This section is specifically about safety matters

Do not attempt to install, operate, maintain or inspect this product until you have read through this Instruction Manual and appended documents carefully and can use the equipment correctly. Do not use this product until you have a full knowledge of the equipment, safety information and instructions.

In this Instruction Manual, the safety instruction levels are classified into "WARNING" and "CAUTION".



### WARNING

Incorrect handling may cause hazardous conditions, resulting in death or severe injury.



### CAUTION

Incorrect handling may cause hazardous conditions, resulting in medium or slight injury, or may cause only material damage.

The  **CAUTION** level may even lead to a serious consequence according to conditions. Both instruction levels must be followed because these are important to personal safety.

## SAFETY INSTRUCTIONS

### 1. Electric Shock Prevention

#### **WARNING**

- While power is ON or when the inverter is running, do not open the front cover. You may get an electric shock.
- Do not run the inverter with the front cover or wiring cover removed. Otherwise, you may access the exposed high-voltage terminals and charging part and get an electric shock.
- Even if power is OFF, do not remove the front cover except for wiring or periodic inspection. You may accidentally touch the charged inverter circuits and get an electric shock.
- Before wiring or inspection, power must be switched OFF. To confirm that, LED indication of the operation panel must be checked. (It must be OFF.) Any person who is involved in wiring or inspection shall wait for at least 10 minutes after the power supply has been switched OFF and check that there are no residual voltage using a tester or the like. The capacitor is charged with high voltage for some time after power OFF, and it is dangerous.
- Any person who is involved in wiring or inspection of this equipment shall be fully competent to do the work.
- The plug-in option must be installed before wiring. Otherwise, you may get an electric shock or be injured.
- Do not touch the plug-in option or handle the cables with wet hands. Otherwise you may get an electric shock.
- Do not subject the cables to scratches, excessive stress, heavy loads or pinching. Otherwise you may get an electric shock.

## 2. Injury Prevention

### CAUTION

- The voltage applied to each terminal must be the ones specified in the Instruction Manual. Otherwise burst, damage, etc. may occur.
- The cables must be connected to the correct terminals. Otherwise burst, damage, etc. may occur.
- Polarity must be correct. Otherwise burst, damage, etc. may occur.
- While power is ON or for some time after power-OFF, do not touch the inverter as they will be extremely hot. Doing so can cause burns.

## 3. Additional Instructions

Also the following points must be noted to prevent an accidental failure, injury, electric shock, etc.

### 1) Transportation and mounting

### CAUTION

- Do not install or operate the plug-in option if it is damaged or has parts missing.
- Do not stand or rest heavy objects on the product.
- The mounting orientation must be correct.
- Foreign conductive objects must be prevented from entering the inverter. That includes screws and metal fragments or other flammable substances such as oil.

### 2) Trial run

### CAUTION

- Before starting operation, each parameter must be confirmed and adjusted. A failure to do so may cause some machines to make unexpected motions.

## 3) Usage

### WARNING

- Do not modify the equipment.
- Do not perform parts removal which is not instructed in this manual. Doing so may lead to fault or damage of the inverter.

### CAUTION

- When parameter clear or all parameter clear is performed, the required parameters must be set again before starting operations because all parameters return to the initial value.
- For prevention of damage due to static electricity, nearby metal must be touched before touching this product to eliminate static electricity from your body.

### 4) Maintenance, inspection and parts replacement

### CAUTION

- Do not test the equipment with a megger (measure insulation resistance).

### 5) Disposal

### CAUTION

- This inverter plug-in option must be treated as industrial waste.

### 6) General instruction

Many of the diagrams and drawings in this Instruction Manual show the inverter without a cover or partially open for explanation. Never operate the inverter in this manner. The cover must be reinstalled and the instructions in the inverter manual must be followed when operating the inverter.

# — CONTENTS —

<b>1</b>	<b>PRE-OPERATION INSTRUCTIONS</b>	<b>1</b>
<b>1.1</b>	<b>Unpacking and product confirmation</b>	<b>1</b>
1.1.1	SERIAL number	1
1.1.2	Product confirmation	2
1.1.3	Parts	3
<b>1.2</b>	<b>Node address setting</b>	<b>4</b>
<b>1.3</b>	<b>Specifications</b>	<b>5</b>
1.3.1	Inverter option specifications	5
1.3.2	Communication specifications	5
<b>2</b>	<b>INSTALLATION</b>	<b>6</b>
<b>2.1</b>	<b>Pre-installation instructions</b>	<b>6</b>
<b>2.2</b>	<b>Installation procedure</b>	<b>6</b>
<b>3</b>	<b>WIRING</b>	<b>12</b>
<b>3.1</b>	<b>Terminal block</b>	<b>12</b>
<b>3.2</b>	<b>Wiring</b>	<b>13</b>
<b>4</b>	<b>INVERTER SETTING</b>	<b>18</b>
<b>4.1</b>	<b>Parameter list</b>	<b>18</b>

<b>4.2</b>	<b>Operation mode setting</b> .....	<b>19</b>
4.2.1	Operation mode indicator .....	19
4.2.2	Operation mode switching and communication startup mode (Pr. 79, Pr. 340) .....	20
<b>4.3</b>	<b>Start and speed command sources (Pr. 338, Pr. 339, Pr. 550)</b> .....	<b>23</b>
4.3.1	Communication EEPROM write selection (Pr. 342) .....	27
<b>4.4</b>	<b>Operation at communication error occurrence</b> .....	<b>28</b>
4.4.1	Operation selection at communication error occurrence (Pr. 500 to Pr. 502) .....	28
4.4.2	Fault and measures .....	32
<b>4.5</b>	<b>Inverter reset</b> .....	<b>33</b>
<b>5</b>	<b>FUNCTIONS</b>	<b>35</b>
<hr/> <hr/>		
<b>5.1</b>	<b>Output from the inverter to the network</b> .....	<b>35</b>
<b>5.2</b>	<b>Input to the inverter from the network</b> .....	<b>36</b>
<b>6</b>	<b>PROFIBUS DEVICE DATA</b>	<b>37</b>
<hr/> <hr/>		
<b>6.1</b>	<b>Device data (GSD file)</b> .....	<b>37</b>
<b>6.2</b>	<b>Slave user parameter</b> .....	<b>41</b>
<b>7</b>	<b>PPO TYPE SUPPORT SPECIFICATION</b>	<b>42</b>
<hr/> <hr/>		
<b>7.1</b>	<b>PROFIBUS profiles</b> .....	<b>42</b>
<b>7.2</b>	<b>ID definitions</b> .....	<b>43</b>
<b>7.3</b>	<b>Buffer memory map</b> .....	<b>44</b>

<b>7.4</b>	<b>Buffer memory configuration .....</b>	<b>45</b>
<b>7.5</b>	<b>Buffer memory details .....</b>	<b>46</b>
<b>7.6</b>	<b>Outline of PNU.....</b>	<b>53</b>
<b>7.7</b>	<b>PROFIBUS PNU.....</b>	<b>54</b>
7.7.1	Real-time monitor .....	54
7.7.2	Parameter clear .....	55
7.7.3	Operation mode read/write .....	55
7.7.4	Set frequency read .....	55
7.7.5	Terminal input read.....	56
7.7.6	Inverter reset .....	56
7.7.7	Node address read .....	56
7.7.8	Fault records read .....	57
7.7.9	PNU list read .....	61
<b>7.8</b>	<b>Standard parameters .....</b>	<b>62</b>
<b>8</b>	<b>PPO TYPE NON-SUPPORT SPECIFICATION .....</b>	<b>64</b>
<hr/>		
<b>8.1</b>	<b>PROFIBUS profiles .....</b>	<b>64</b>
<b>8.2</b>	<b>ID definitions .....</b>	<b>65</b>
<b>8.3</b>	<b>Buffer memory map .....</b>	<b>65</b>
<b>8.4</b>	<b>Buffer memory configuration .....</b>	<b>66</b>
<b>8.5</b>	<b>Buffer memory details .....</b>	<b>67</b>
<b>8.6</b>	<b>Outline of PNU.....</b>	<b>72</b>
<b>8.7</b>	<b>PROFIBUS PNU (Module type E5NP) .....</b>	<b>73</b>
8.7.1	Real-time monitor area (IND=0000H (IND=00H, PP=00H)).....	73

8.7.2	System environment variable (sev) area (IND = 01PPH (IND = 01H, PP = 00H, 01H))	74
<b>8.8</b>	<b>Standard parameters</b>	<b>78</b>
8.8.1	Normal parameter area (IND = 0200H (IND = 02H, PP = 00H))	78
8.8.2	Pr. 900 to calibration parameter (frequency) area (IND=0300H (IND=03H, PP=00H))	79
8.8.3	Pr. 900 to calibration parameter (%) area (IND=0400H (IND=04H, PP=00H))	80
<b>9</b>	<b>TROUBLESHOOTING</b>	<b>81</b>

---

---

# 1 PRE-OPERATION INSTRUCTIONS

## 1.1 Unpacking and product confirmation

Take the plug-in option out of the package, check the product name, and confirm that the product is as you ordered and intact.

This product is a plug-in option for the FR-E700 series inverter.

### 1.1.1 SERIAL number

Check the SERIAL number indicated on the inverter rating plate or package.

For the 200V class of FR-E700, this option can be used with the inverter having the following SERIAL number or later. (For the 400V class of FR-E700, this option can be used with all inverters regardless of SERIAL number.)

Model	SERIAL number
FR-E720-0.1K to 0.75K	J7Y○○○○○○
FR-E720-1.5K to 5.5K	K7Y○○○○○○
FR-E720-7.5K	L7Y○○○○○○
FR-E720-11K, 15K	G7Y○○○○○○

#### ● SERIAL number check

Refer to the inverter manual for the location of the rating plate.

#### Rating plate example

<u>□</u>	<u>Z</u>	<u>Y</u>	<u>○○○○○○</u>
Symbol	Year	Month	Control number
SERIAL number			



The SERIAL consists of one symbol, two characters indicating production year and month, and six characters indicating control number.

The last digit of the production year is indicated as the Year, and the Month is indicated by 1 to 9, X (October), Y (November), or Z (December).

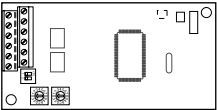

## 1.1.2 Product confirmation

Check the enclosed items.

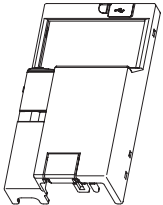
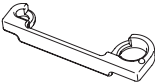
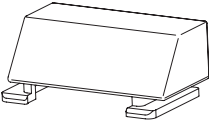
<p>Plug-in option ..... 1</p> 	<p>Mounting screw (M3 × 6mm) ..... 2 (Refer to page 8, 10.)</p> 	
<p>Front cover for plug-in option ..... 1</p> 	<p>Option protective cover ..... 1 *</p> 	<p>Option small cover (Not used) ..... 1</p> 

\* Used with the FR-E720-3.7K (FR-E720-175) or lower and FR-E740-7.5K (FR-E740-170) or lower.

### CAUTION

- Install a provided front cover for plug-in option in place of the inverter front cover.

### REMARKS

- PROFIBUS® is a registered trademark of PROFIBUS User Organization.

### 1.1.3 Parts

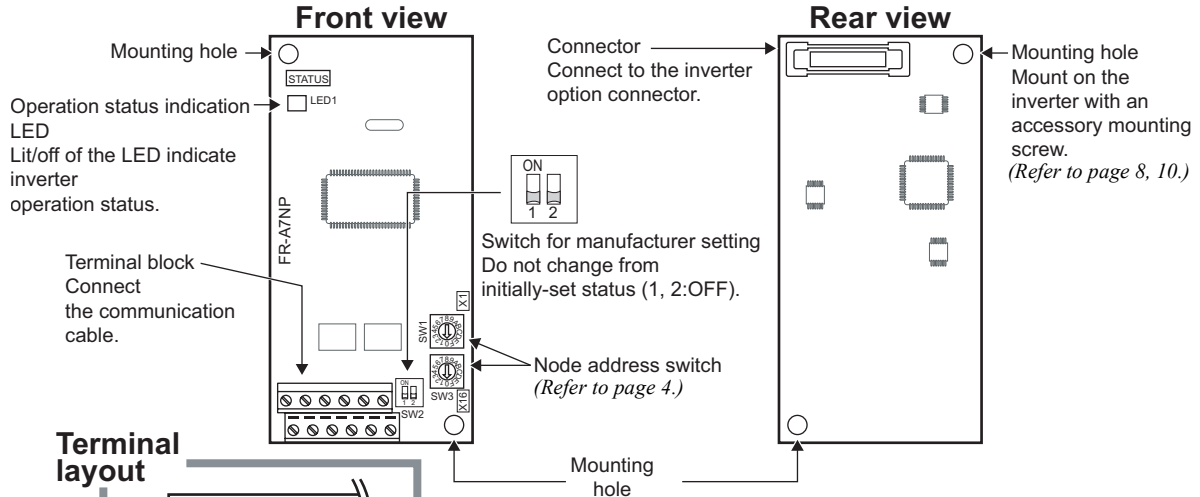

#### Terminal layout

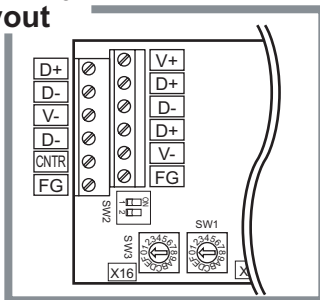



Name	Function	
Node address switch	Set the inverter address within the range of 00H to 7DH.	
Operation status indication LED	<b>OFF</b>	Inverter power OFF
	<b>Red is lit</b>	A communication error with the master occurred
	<b>Green is lit</b>	During communication with the master

## 1.2 Node address setting

Set the node address between "00H to 7DH" using node address switches on FR-A7NP (refer to page 3). The setting is applied at the next power-ON.

Set the arrow (↑) of the corresponding switches to a number or an alphabet to set a desired address.

- Setting example

<p>Node address 1: Set the "↑" of X16(SW3) to "0" and the "↑" of X1(SW1) to "1".</p>  <p>The diagram shows two rotary switches. The top switch is labeled 'X1' and has positions for '0', '1', '2', '3', '4', '5', '6', '7', '8', '9', 'A', 'B', 'C', 'D', 'E', 'F', 'G', 'H'. The arrow points to '1'. The bottom switch is labeled 'X16' and has positions for '0', '1', '2', '3', '4', '5', '6', '7', '8', '9', 'A', 'B', 'C', 'D', 'E', 'F', 'G', 'H'. The arrow points to '0'.</p>	<p>Node address 38 (26H): Set the "↑" of X16(SW3) to "2" and the "↑" of X1(SW1) to "6".</p>  <p>The diagram shows two rotary switches. The top switch is labeled 'X1' and has positions for '0', '1', '2', '3', '4', '5', '6', '7', '8', '9', 'A', 'B', 'C', 'D', 'E', 'F', 'G', 'H'. The arrow points to '6'. The bottom switch is labeled 'X16' and has positions for '0', '1', '2', '3', '4', '5', '6', '7', '8', '9', 'A', 'B', 'C', 'D', 'E', 'F', 'G', 'H'. The arrow points to '2'.</p>
--	---

### CAUTION

- Set the node address switch to the switch number (alphabet) position correctly. If the switch is set between numbers, normal data communication cannot be established.
- Do not set the node addresses to 7EH through FFH. When these addresses are set, they are recognized as 7DH.
- The node addresses, 00H, 01H, 02H, 7CH, and 7DH, may not be available for some master modules.
- You cannot set the same node address to other devices on the network. (Doing so disables proper communication.)
- Set the inverter node address before switching ON the inverter and do not change the setting while power is ON. Otherwise you may get an electric shock.

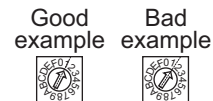

## 1.3 Specifications

### 1.3.1 Inverter option specifications

Type	Inverter plug-in option type
Number of nodes occupied	One inverter occupies one node.
Connection cable	Cable which supports 12.0Mbps communication (EIA-485(RS-485) standard)

### 1.3.2 Communication specifications

Communication speed	Wiring length 1200m or less	9600bps, 19.2Kbps, 93.75Kbps
	Wiring length 600m or less	187.5Kbps
	Wiring length 200m or less	500Kbps, 1.5Mbps
	Wiring length 100m or less	3.0Mbps, 6.0Mbps, 12.0Mbps

## 2 INSTALLATION

### 2.1 Pre-installation instructions

Make sure that the input power of the inverter is OFF.

#### ⚠ CAUTION

- ⚠ With input power ON, do not install or remove the plug-in option. Otherwise, the inverter and plug-in option may be damaged.
- ⚠ For prevention of damage due to static electricity, touch nearby metal before touching this product to eliminate static electricity from your body.

### 2.2 Installation procedure

The FR-E700 series has one connection connector for the plug-in option.

#### CAUTION

- Always perform wiring to the main circuit terminals and control circuit terminals before installing the option. Wiring cannot be performed after installing the option.  
For wiring to terminals RUN, FU, and SE of control circuit terminal, run cables to prevent them from being caught between the option board and control circuit terminal block as shown in the right figure. In case cables are caught, the inverter may be damaged.
- When the inverter cannot recognize that the option unit is mounted due to improper installation, etc., "E. 1" (option fault) is displayed.
- Take care not to drop a mounting screw during mounting and removal.
- Pull out the option straight to remove. Otherwise, the connector may be damaged.

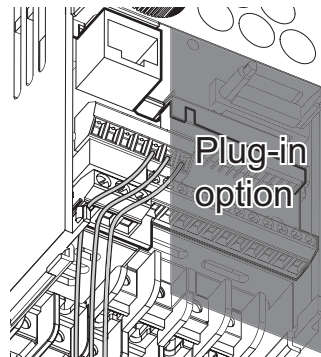

● Inverter with one front cover

- (1) Remove the front cover from the inverter. (For removing the front cover, refer to the FR-E700 instruction manual.)
- (2) Remove the PU cover from the front cover. Open the PU cover with a driver, etc. and remove it in the direction of arrow as shown below.

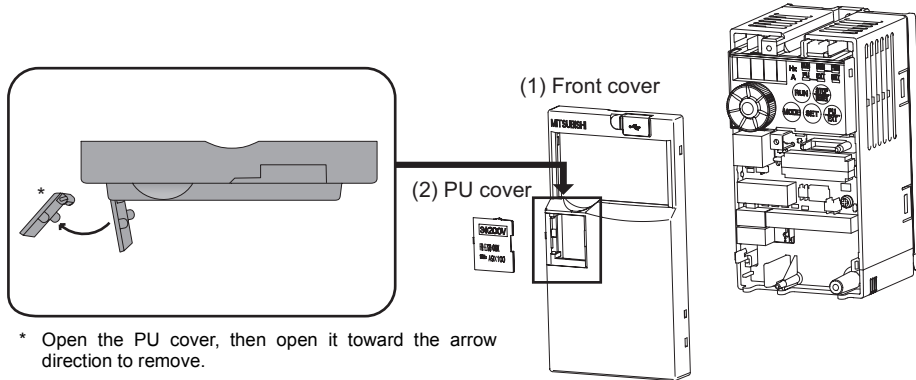

\* Open the PU cover, then open it toward the arrow direction to remove.

## REMARKS

- Because the voltage class, model name and serial (only voltage class is labeled for FR-E740-5.5K (FR-E740-120) or higher) are stated on the PU cover, replace a PU cover of a plug-in option front cover with the removed PU cover from the inverter.

## 7 INSTALLATION

- (3) Install the option protective cover.
- (4) Securely fit the connector of the plug-in option to the inverter connector along the guides.
- (5) Securely fix the both top and bottom of the plug-in option to the inverter with the accessory mounting screws. (tightening torque  $0.45\text{N}\cdot\text{m}$  to  $0.55\text{N}\cdot\text{m}$ ) If the screw holes do not line-up, the connector may not have been plugged snugly. Check for loose plugging.
- (6) Remove the PU cover provided on the front cover for plug-in option and install the other PU cover, which was removed in (2).
- (7) Loosen the terminal screw and insert the cable into the terminal. Tighten each cable with fixing screws to the recommended tightening torque. (Refer to *Chapter 3* for wiring.)
- (8) Install the front cover for plug-in option to the inverter.

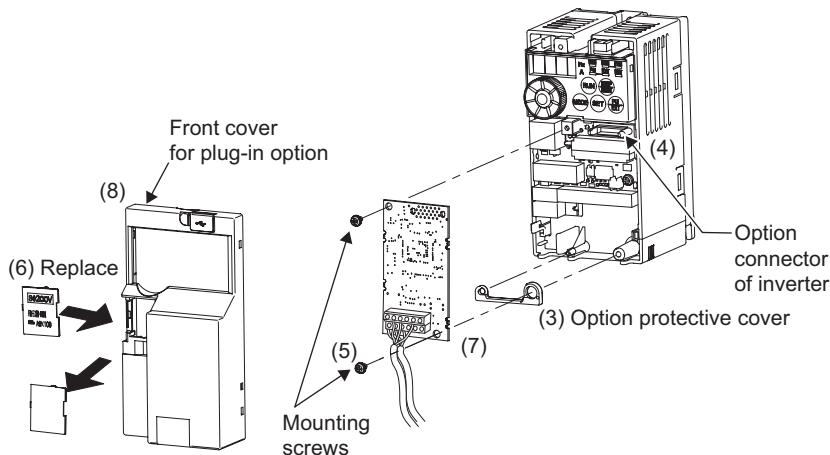

### REMARKS

- When the option protective cover is not installed, the protective structure (JEM1030) changes to open type (IP00).

● Inverter with front covers 1 and 2

- (1) Remove the front covers 1 and 2 from the inverter. (For removing the front cover, refer to the FR-E700 instruction manual.)
- (2) Remove the PU cover from the front cover 2. For removing the PU cover, refer to *page 7*.

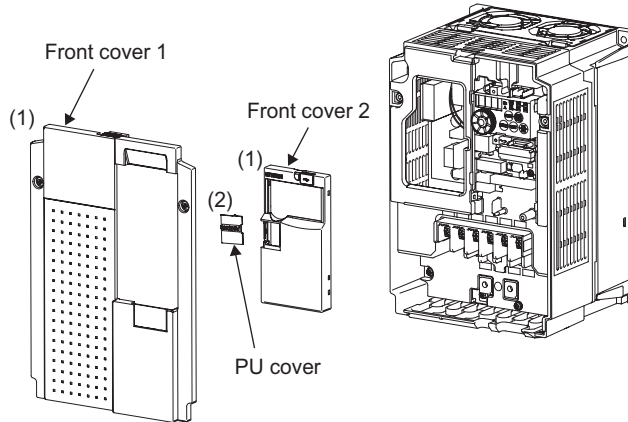

## REMARKS

- Because the voltage class is stated on the PU cover, replace a PU cover of a plug-in option front cover with the removed PU cover from the inverter.



- (3) Install the front cover 1 to the inverter.
- (4) Securely fit the connector of the plug-in option to the inverter connector along the guides.
- (5) Securely fix the both top and bottom of the plug-in option to the inverter with the accessory mounting screws. (tightening torque  $0.45\text{N}\cdot\text{m}$  to  $0.55\text{N}\cdot\text{m}$ ) If the screw holes do not line up, the connector may not have been plugged securely. Check for loose plugging.
- (6) Remove the PU cover provided on the front cover for plug-in option and install the other PU cover, which was removed in (2).
- (7) Loosen the terminal screw and insert the cable into the terminal. Tighten each cable with fixing screws to the recommended tightening torque. (Refer to *Chapter 3* for wiring.)
- (8) Install the front cover for plug-in option to the inverter.

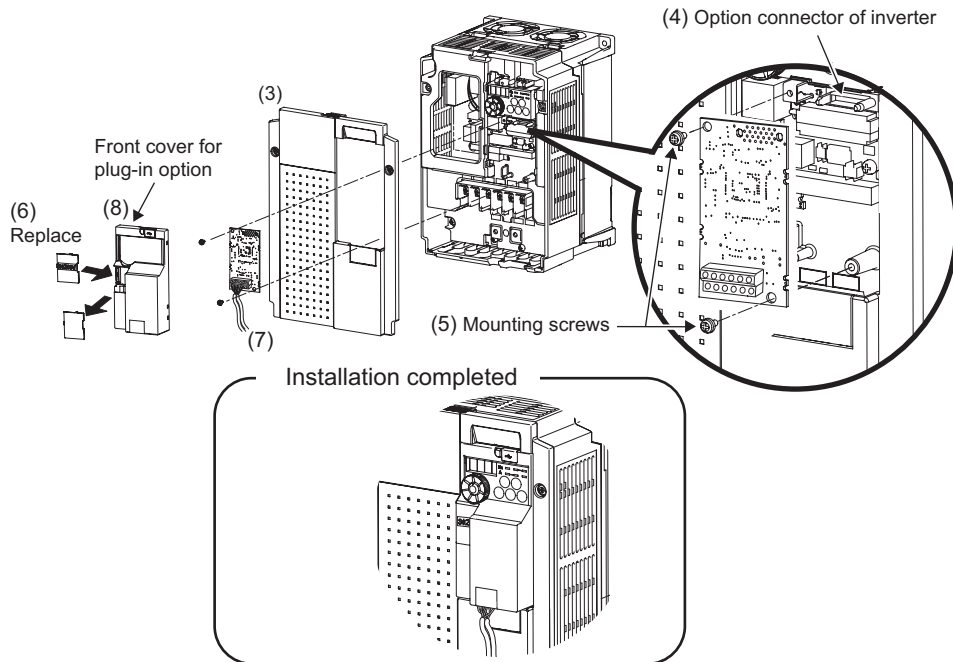

# 3 WIRING

## 3.1 Terminal block

Terminal block layout

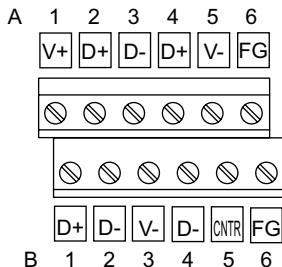

Terminal No.	Terminal Name	Definition
1-A	V+ (VP) *1	Voltage output (approx. 5V to V-)
1-B	D+ (RXD/TXD-P)	Sends and receives PROFIBUS signal+ (B-line)
2-A	D+ (RXD/TXD-P)	Sends and receives PROFIBUS signal+ (B-line)
2-B	D+ (RXD/TXD-N)	Sends and receives PROFIBUS signal- (A-line)
3-A	D+ (RXD/TXD-N)	Sends and receives PROFIBUS signal- (A-line)
3-B	V- (DGND) *1	GND of D+/D-
4-A	D+ (RXD/TXD-P) *1	(To connect a terminating resistor)
4-B	D+ (RXD/TXD-N) *1	(To connect a terminating resistor)
5-A	V- (DGND) *1	GND of D+/D-
5-B	CNTR *2	Control signal (sending request from the inverter)
6-A	FG	(Connected to the earth of the inverter unit)
6-B	FG	(Connected to the earth of the inverter unit)

\*1 Use this when connecting a terminating resistor. (Refer to page 15)

\*2 It may not be necessary depending on the master used.

## 3.2 Wiring

Use the network connection cable which supports 12.0Mbps communication.

- (1) Strip off the sheath of the PROFIBUS communication dedicated cable and wind wires and shield cables to use. If the length of the sheath peeled is too long, a short circuit may occur among neighboring wires. If the length is too short, cables and shield cables might come off.

Cable stripping length Approx 5mm

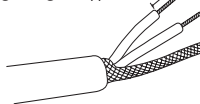

**Wire the stripped cable after twisting it to prevent it from becoming loose.  
(Do not solder it.)  
Use a blade terminal as required.**

### REMARKS

- Information on blade terminals...recommended product (as of January 2010)

Terminal Screw Size	Cable Size (mm <sup>2</sup> )	Blade Terminal Model		Manufacturer
		With insulation sleeve	Without insulation sleeve	
M2	0.3 to 0.5	AI 0,5-6WH	A 0,5-6	Phoenix Contact Co.,Ltd.

Blade terminal crimping tool: CRIMPFOX 6 (Phoenix Contact Co., Ltd.)

When using the blade terminal (without insulation sleeve), use care so that the twisted wires do not come out.

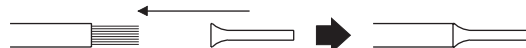

- (2) Loosen the terminal screw and insert the cable into the terminal.  
Tighten each cable with fixing screws to the recommended tightening torque.

<Cable connection example>

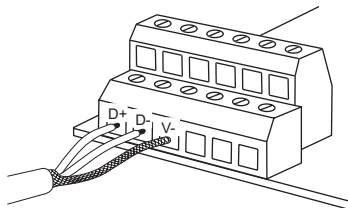

<Connection example of multiple inverters>

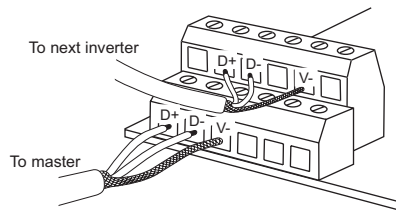

Screw Size	Tightening Torque	Cable Size	Screwdriver
M2	0.22N·m to 0.25N·m	0.3mm <sup>2</sup> to 0.75mm <sup>2</sup>	Small ⊖ flat-blade screwdriver (Tip thickness: 0.4mm /tip width: 2.5mm)

## CAUTION

- Undertightening can cause cable disconnection or malfunction. Overtightening can cause a short circuit or malfunction due to damage to the screw or unit.

(3) Terminating resistor

Connect terminating resistors to the both ends of a network if the both ends are FR-A7NP-mounted inverters.

Connection example

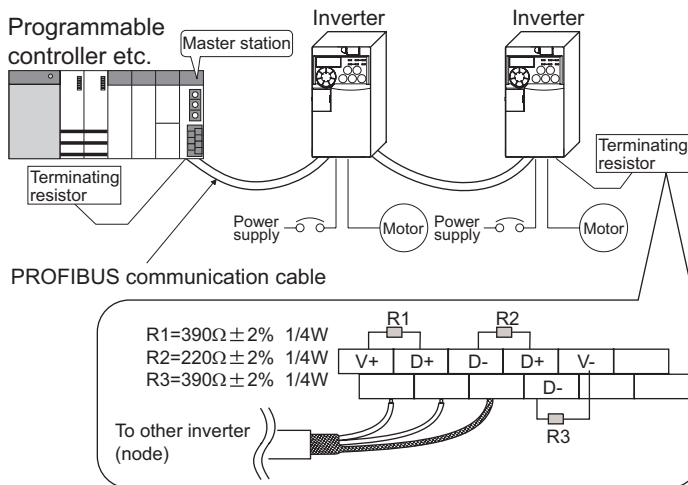

- (4) When wiring, if a hook of the front cover of the plug-in option impedes wiring, cut off the hook and perform wiring.

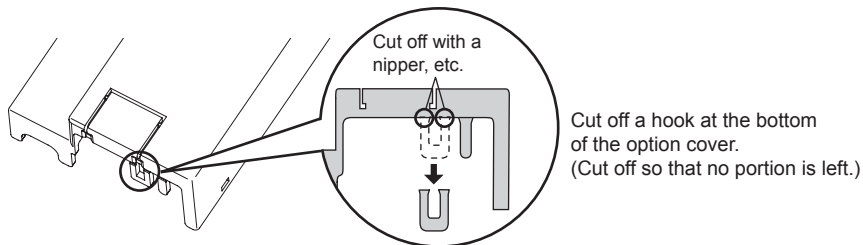

### REMARKS

- When the option protective cover is not fitted or wire is not passed through even if the hook of the front cover of the plug-in option has been cut off, the protective structure (JEM1030) changes to open type (IP00).

- (5) When wiring an inverter, which has front covers 1 and 2, pass the cable over the front cover 1 as shown below. If a PROFIBUS communication dedicated cable is passed through underneath the inverter front cover 1, the bending radius of the cable shortens, stressing the cable.

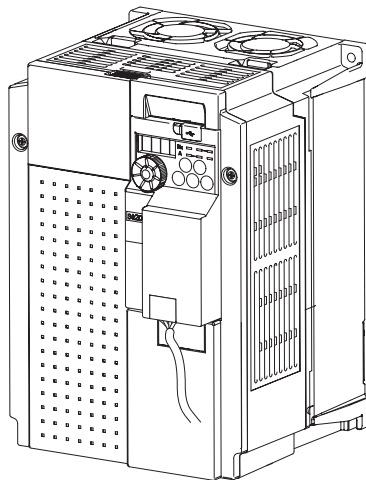

3

**⚠ CAUTION**

- ⚠ When wiring, take care not to subject the cable to stress.**
- ⚠ After wiring, wire offcuts must not be left in the inverter. They may cause a fault, failure or malfunction.**



# 4 INVERTER SETTING

## 4.1 Parameter list

The following parameters are used for the communication option (FR-A7NP).  
Set the values according to need.

Parameter Number	Name	Setting Range	Minimum Setting Increments	Initial Value	Refer to page
79	Operation mode selection	0 to 4, 6, 7	1	0	20
338	Communication operation command source	0, 1	1	0	23
339	Communication speed command source	0, 1, 2	1	0	23
340	Communication startup mode selection	0, 1, 10	1	0	20
342	Communication EEPROM write selection	0, 1	1	0	27
349 *1	Communication reset selection	0, 1	1	0	34
500 *1	Communication error execution waiting time	0 to 999.8s	0.1s	0	28
501 *1	Communication error occurrence count display	0	1	0	29
502 *2	Stop mode selection at communication error	0, 1, 2, 3	1	0	30
550 *2	NET mode operation command source selection	0, 2, 9999	1	9999	23

\*1 Parameters which can be displayed when the plug-in option (FR-A7NP) is mounted.

\*2 The setting is applied after inverter reset or at the next power-ON.

## 4.2 Operation mode setting

The inverter mounted with a communication option has three operation modes.

- (1) PU operation [PU]..... Controls the inverter from the keys of the operation panel on the inverter or parameter unit (FR-PU07/FR-PA07).
- (2) External operation [EXT] ... Controls the inverter by switching ON/OFF external signals connected to the control circuit terminals of the inverter.  
(The inverter is factory-set to this mode.)
- (3) Network operation [NET] ... Controls the inverter with instructions from the network via the communication option.  
(The operation signal and running frequency can be entered from the control circuit terminals depending on the *Pr. 338 Communication operation command source* and *Pr. 339 Communication speed command source* settings.  
*Refer to page 24.*)

### 4.2.1 Operation mode indicator

Operation panel



Operation mode indicators  
(The inverter operates according to the LED lit mode.)  
PU: PU operation mode  
EXT: External operation mode  
NET: Network operation mode

### **4.2.2 Operation mode switching and communication startup mode (Pr. 79, Pr. 340)**

#### **(1) Operation mode switching conditions**

Before switching the operation mode, check that:

- 1) The inverter is at a stop;
- 2) Both the STF and STR signals are OFF; and
- 3) The *Pr. 79 Operation mode selection* setting is correct.

(Set using the operation panel of the inverter or parameter unit (FR-PU07/FR-PA07).)

Refer to *the Inverter Manual* for details of *Pr. 79*.

#### **(2) Operation mode selection at power ON and at restoration from instantaneous power failure**

The operation mode at power ON and at restoration from instantaneous power failure can be selected.

Set a value other than "0" in *Pr. 340* to select the network operation mode.

After started in Network operation mode, parameter write from the network is enabled.

#### **REMARKS**

- Change of the *Pr. 340* setting is applied valid power ON or an inverter reset.
- *Pr. 340* can be changed with the operation panel in any operation mode.

Pr. 340 Setting	Pr. 79 Setting	Operation Mode at Power ON or Power Restoration	Operation Mode Switchover
0 (initial value)	0 (initial value)	External operation mode	Switching among the External, PU, and NET operation mode is enabled *1
	1	PU operation mode	PU operation mode fixed
	2	External operation mode	Switching between the external and NET operation mode is enabled Switching to the PU operation mode is disallowed
	3, 4	External/PU combined operation mode	Operation mode switching is disallowed
	6	External operation mode	Switching among the External, PU, and NET operation mode is enabled while running.
	7	X12 (MRS) signal ON ..... External operation mode	Switching among the External, PU, and NET operation mode is enabled *1
X12 (MRS) signal OFF ... External operation mode		External operation mode fixed (Forcibly switched to external operation mode.)	
1	0	NET operation mode	Same as when Pr. 340 = "0"
	1	PU operation mode	
	2	NET operation mode	
	3, 4	External/PU combined operation mode	
	6 *3	NET operation mode	
	7	X12 (MRS) signal ON .... NET operation mode	
X12 (MRS) signal OFF ... External operation mode			
10	0	NET operation mode	Switching between the PU and NET operation mode is enabled *2
	1	PU operation mode	Same as when Pr. 340 = "0"
	2	NET operation mode	NET operation mode fixed
	3, 4	External/PU combined operation mode	Same as when Pr. 340 = "0"
	6 *3	NET operation mode	Switching between the PU and NET operation mode is enabled while running *2
	7	External operation mode	Same as when Pr. 340 = "0"

\*1 Operation mode cannot be directly changed between the PU operation mode and Network operation mode.

\*2 Operation mode can be changed between the PU operation mode and Network operation mode with of the operation panel and X65 signal.

\*3 Pr. 79 = "6" and Pr. 128 to Pr. 134 (PID control) are not activated simultaneously. Switchover mode and PID control are made invalid, and the inverter performs the same operation as when "0" is set in Pr. 79.

## (3) Operation mode switching method

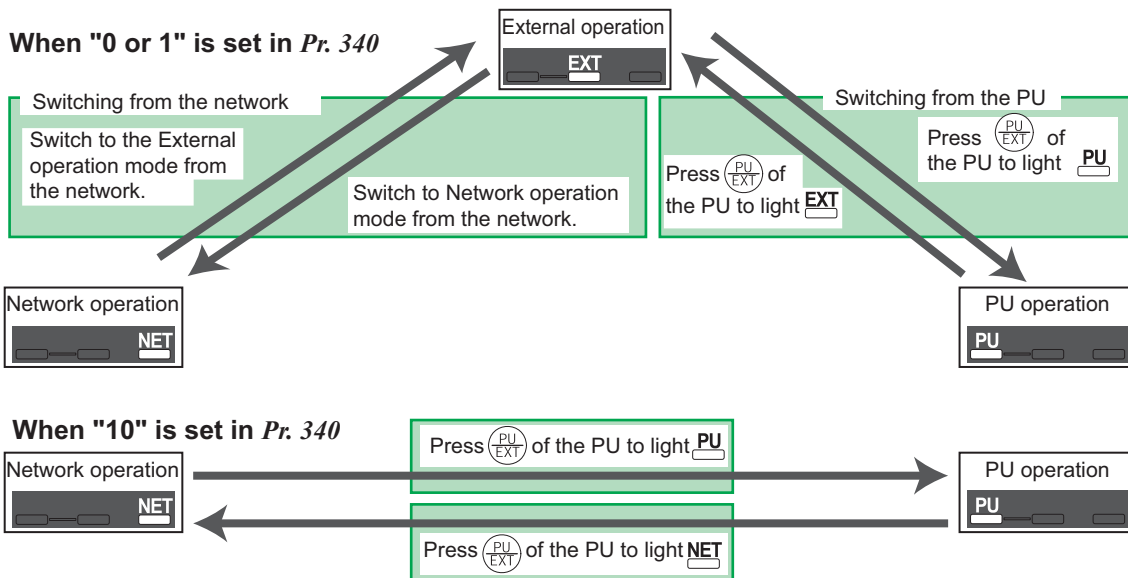

For the switching method from the external terminal, refer to *the Inverter Manual*. Refer to page 55 and 76 for a switching method from the network.

### CAUTION

- When starting the inverter in Network operation mode at power ON or an inverter reset, set a value other than "0" in Pr. 340. (Refer to page 20)
- When setting a value other than "0" in Pr. 340, make sure that the initial settings of the inverter are correct.

### 4.3 Start and speed command sources (Pr. 338, Pr. 339, Pr. 550)

**(1) Select command source for the Network operation mode (Pr. 550)**

A control location for the Network operation mode can be selected from either the RS-485 communication with the PU connector or a communication option.

When using a communication option, set "0 or 9999 (initial value)" in Pr. 550.

Parameter Number	Name	Initial Value	Setting Range	Description
550	NET mode operation command source selection	9999	0	The communication option is the command source when NET operation mode.
			2	PU connector is the command source when NET operation mode.
			9999	Automatic communication option recognition Normally, PU connector is the command source. When a communication option is mounted, the communication option is the command source.

*Refer to the inverter manual for details.*

## (2) Selection of control source for the network operation mode (Pr. 338, Pr. 339)

- There are two command types: the start command, which controls the signals related to the inverter start command and function selection, and the speed command, which controls signals related to frequency setting.
- In Network operation mode, the commands from the external terminals and communication (PU connector or communication option) are as listed below.

Operation Location Selection		Pr. 338 Communication operation command source		0: NET			1: External			Remarks	
		Pr. 339 Communication speed command source		0: NET	1: External	2: External	0: NET	1: External	2: External		
Fixed function (terminal-equivalent function)	Running frequency from communication		NET	—	NET	NET	—	NET			
	Terminal 2		—	External	—	—	External	—			
	Terminal 4		—	External		—	External				
Selective function	Pr. 178 to Pr. 184 setting	0	RL	Low speed operation command/remote setting clear/stop-on contact selection 0	NET	External		NET	External		Pr. 59 = "0" (multi-speed) Pr. 59 = "1, 2" (remote) Pr. 270 = "1" (stop-on-contact)
		1	RM	Middle speed operation command/remote setting function	NET	External		NET	External		
		2	RH	High speed operation command/remote setting function	NET	External		NET	External		
		3	RT	Second function selection/stop-on contact selection 1	NET			External			Pr. 270 = "1" (stop-on-contact)
		4	AU	Terminal 4 input selection	—	Combined		—	Combined		
		5	JOG	Jog operation selection	—			External			

Operation Location Selection		Pr. 338 Communication operation command source		0: NET			1: External			Remarks		
		Pr. 339 Communication speed command source		0: NET	1: External	2: External	0: NET	1: External	2: External			
Selective function	Pr. 178 to Pr. 184 setting	7	OH	External thermal relay input		External						
		8	REX	15-speed selection	NET	External		NET	External			Pr. 59 = "0" (multi-speed)
		10	X10	Inverter run enable signal	External							
		12	X12	PU operation external interlock	External							
		14	X14	PID control valid terminal	NET	External		NET	External			
		15	BRI	Brake opening completion signal	NET			External				
		16	X16	PU-External operation switchover	External							
		18	X18	V/F switchover	NET			External				
		24	MRS	Output stop	Combined			External				Pr. 79 ≠ "7"
				PU operation interlock	External							Pr. 79 = "7" When the X12 signal is not assigned
25	STOP	Start self-holding selection	—			External						
60	STF	Forward rotation command	NET			External						



## 7 INVERTER SETTING

Operation Location Selection		Pr. 338 Communication operation command source		0: NET			1: External			Remarks
		Pr. 339 Communication speed command source		0: NET	1: External	2: External	0: NET	1: External	2: External	
Selective function Pr. 178 to Pr. 184 setting	61	STR	Reverse rotation command	NET			External			
	62	RES	Inverter reset				External			
	65	X65	PU/NET operation switchover				External			
	66	X66	External/NET operation switchover				External			
	67	X67	Command source switchover				External			

### [Explanation of table]

External : Command is valid only from control terminal.

NET : Command only from communication is valid

Combined : Command from both control terminal and communication is valid.

— : Command from either of control terminal and communication is invalid.

### REMARKS

- The command source of communication is as set in Pr. 550 and Pr. 551.
- The Pr. 338 and Pr. 339 settings can be changed while the inverter is running when Pr. 77 = "2". Note that the setting change is applied after the inverter has stopped. Until the inverter has stopped, communication operation command source and communication speed command source before the setting change are valid.

### 4.3.1 Communication EEPROM write selection (Pr. 342)

When parameter write is performed from the communication option, write to RAM is enabled. Set when frequent parameter changes are necessary.

Parameter Number	Name	Initial Value	Setting Range	Description
342	Communication EEPROM write selection	0	0	Parameter values written by communication are written to the EEPROM and RAM.
			1	Parameter values written by communication are written to the RAM.

- When changing the parameter values frequently, set "1" in *Pr. 342* to write them to the RAM. Performing frequent parameter write with "0 (initial value)" (EEPROM write) set will shorten the life of the EEPROM.

#### REMARKS

- When "1" (write to RAM only) is set in *Pr. 342*, powering OFF the inverter will erase the changed parameter values. Therefore, the parameter values available when power is switched ON again are the values stored in EEPROM previously.

## 4.4 Operation at communication error occurrence

### 4.4.1 Operation selection at communication error occurrence (Pr. 500 to Pr. 502)

You can select operations at communication error occurrences by setting *Pr. 500* to *Pr. 502* under network operation.

#### (1) Waiting time for the communication line error output after a communication error

Waiting time for the communication error output after a communication line error occurrence can be set.

Parameter Number	Name	Setting Range	Minimum Setting Increments	Initial Value
500	Communication error execution waiting time	0 to 999.8s	0.1s	0

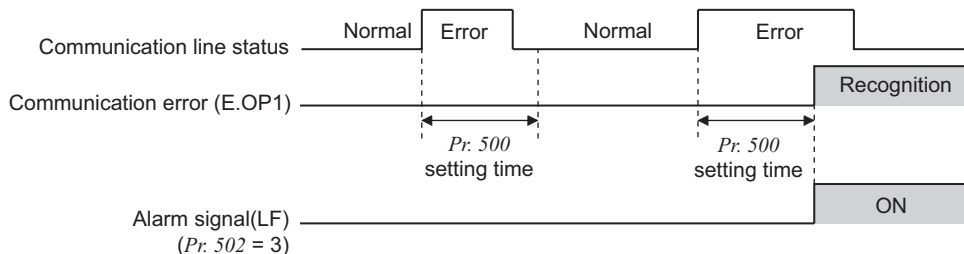

When a communication line error occurs and lasts longer than the time set in *Pr. 500*, it is recognized as a communication error.

If the communication returns to normal within the time, it is not recognized as a communication error, and the operation continues.

**(2) Displaying and clearing the communication error count**

The cumulative count of communication error occurrences can be displayed.

Write "0" to clear this cumulative count.

Parameter Number	Name	Setting Range	Minimum Setting Increments	Initial Value
501	Communication error occurrence count display	0	1	0

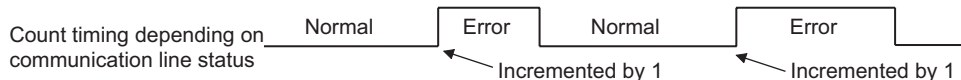

At the point of communication line error occurrence, *Pr. 501 Communication error occurrence count display* is incremented by 1.

**CAUTION**

- **Communication error count is temporarily stored in the RAM. The error count is stored in EEPROM only once per hour. If power reset or inverter reset is performed, *Pr. 501* setting will be the one that is last stored to EEPROM depending on the reset timing.**

## (3) Inverter operation at a communication error occurrence

How the inverter operates at a communication line error or an option unit fault can be set.

Parameter Number	Name	Setting Range	Minimum Setting Increments	Initial Value
502	Stop mode selection at communication error	0, 1, 2, 3	1	0

### About setting

#### ● Operation at an error occurrence

Error Definition	Pr. 502 Setting	Operation	Indication	Fault Output
Communication line	0	Continued *	Normal indication *	Not provided *
	1			
	2			
	3			
Communication option itself	0, 3	Coast to stop	E. 1 lit	Provided
	1, 2	Decelerated to stop	E. 1 lit after stop	Provided after stop

\* When the communication returns to normal within the time period set in Pr. 500, the communication option error (E.OP1) does not occur.

#### ● Operation at error recognition after elapse of Pr. 500 time

Error Definition	Pr. 502 Setting	Operation	Indication	Fault Output
Communication line	0	Coast to stop	E.OP1 lit	Provided
	1	Decelerated to stop	E.OP1 lit after stop	Provided after stop
	2			Not provided
	3	Continued	Normal indication	
Communication option itself	0, 3	Coast to stop	E. 1 lit	Provided
	1, 2	Decelerated to stop	E. 1 lit after stop	Provided after stop

● **Operation at error removal**

Error Definition	Pr. 502 Setting	Operation	Indication	Fault Output
Communication line	0	Kept stopped	E.OP1 kept lit	Kept provided
	1			
	2	Restart	Normal indication	Not provided
	3	Continued		
Communication option itself	0, 3	Kept stopped	E. 1 kept lit	Kept provided
	1, 2			

**CAUTION**

- Communication line error [E.OP1 (fault data: HA1)] is an error that occurs on the communication line. Communication option error [E. 1 (fault data: HF1)] is an error that occurs in the communication circuit inside the option.
- Fault output indicates the fault output signal (ALM signal) and fault bit output.
- When the fault output setting is active, fault records are stored in the faults history. When the fault output setting is not active, fault record is overwritten to the faults history temporarily but not stored. After the error is removed, the fault indication is reset, changing the display back to normal, and the last fault is displayed in the faults history.
- When the Pr. 502 setting is "1" or "2", the deceleration time is the normal deceleration time setting (e.g. Pr. 8, Pr. 44, Pr. 45).
- The acceleration time at a restart is the normal acceleration time setting (e.g. Pr. 7, Pr. 44).
- When the Pr. 502 setting is "2", the operation/speed command at a restart is the one given before the error occurrence.
- When a communication line error occurs at the Pr. 502 setting of "2", removing the error during deceleration causes acceleration to restart at that point. (Acceleration is not restarted if the error is that of the option unit itself.)

## 4.4.2 Fault and measures

(1) The inverter operates as follows at fault occurrences.

Fault Location	Status		Operation Mode		
			Network Operation	External Operation	PU Operation
Inverter	Inverter operation		<b>Inverter trip</b>	Inverter trip	Inverter trip
	Data communication		<b>Continued</b>	Continued	Continued
Communication line	Inverter operation		<b>Inverter trip *</b>	Continued	Continued
	Data communication		<b>Stop</b>	Stop	Stop
Communication option	Communication option connection error	Inverter operation	<b>Inverter trip *</b>	Inverter trip *	Inverter trip *
		Data communication	<b>Continued</b>	Continued	Continued
	Error of communication option itself	Inverter operation	<b>Inverter trip *</b>	Continued	Continued
		Data communication	<b>Stop</b>	Stop	Stop

\* Depends on the *Pr. 502* setting.

(2) Measures at error occurrences

Fault Indication	Error Definition	Measures
E.OP1	Communication line error	Check the LED status of the option unit and remove the cause of the alarm. (Refer to <i>page 3</i> for LED indication status) Check the other nodes on the network. Inspect the master.
E.1	Option fault	Check the connection between the inverter and option unit for poor contact, etc. and remove the cause of the error.

When faults other than the above are displayed, refer to the inverter manual and remove the cause of the error.

## 4.5 Inverter reset

### (1) Operation conditions of inverter reset

Which resetting method is allowed or not allowed in each operation mode is described below.

Resetting Method			Operation Mode		
			Network Operation	External Operation	PU Operation
Reset from the network	Inverter reset ( <i>Refer to page 56</i> ) *1		Allowed	Disallowed	Disallowed
	Error reset (STW(bit7)) at inverter fault ( <i>Refer to page 48</i> ) *2	<i>Pr.349 = 0</i>	Allowed	Allowed	Allowed
		<i>Pr.349 = 1</i>		Disallowed	Disallowed
Turn ON the inverter RES signal (terminal RES)			Enabled	Enabled	Enabled
Switch OFF inverter power			Enabled	Enabled	Enabled
Reset from the PU/operation panel	Inverter reset		Enabled	Enabled	Enabled
	Reset at inverter fault		Enabled	Enabled	Enabled

\*1 Inverter reset can be made any time.

\*2 Reset can be made only when the protective function of the inverter is activated. (Available with PPO type 1 to 5 only)

### CAUTION

- When a communication line error has occurred, reset cannot be made from the network.
- The inverter is set to the External operation mode if it has been reset in Network operation mode in the initial status.  
To resume the network operation, the inverter must be switched to the Network operation mode again.  
Set a value other than "0" in *Pr. 340* to start in Network operation mode. (*Refer to page 20.*)
- The inverter cannot be controlled for about 1s after release of a reset command .



### (2) Error reset operation selection at inverter fault

When used with the communication option, an error reset command\* from network can be invalid in the external operation mode or PU operation mode.

Parameter Number	Name	Initial Value	Setting Range	Function
349	Communication reset selection	0	0	Error reset* is enabled independently of operation mode
			1	Error reset* is enabled only in the Network operation mode

\* An error reset command (STW (bit7)) at inverter fault is available with PPO type 1 to 5. (Refer to page 48.)

# 5 FUNCTIONS

## 5.1 Output from the inverter to the network

Main items to be output from the inverter (FR-A7NP) to the network and their descriptions are explained below.

Item	Description	Refer to Page	
		PPO Type Support Specification	PPO Type Non-Support Specification
Inverter monitor	Monitor various items such as inverter output frequency and output current.	54	73
Parameter read	Read parameter settings of the inverter.	46	67
Inverter status	Monitor output signal of the inverter.	49	70
Operation mode read	Read the operation mode of the inverter.	49, 55	—
Set frequency read	Read the frequency set in the inverter.	55	76
Terminal input read	Read the analog value of terminal 2, 4.	56	76
Node address read	Read node address of the inverter.	56	—
Alarm definition read	Monitor alarm history occurred in the inverter and energization time, output frequency, output current and output voltage at alarm occurrence are monitored.	57	77
PNU list read	Read the available PNU number.	61	—

### REMARKS

- Refer to the *inverter manual* for functions controllable from the network in each operation mode.

## 5.2 Input to the inverter from the network

Main items which can be commanded from the network to the inverter and their descriptions are explained below.

Item	Description	Refer to page	
		PPO Type Support Specifications	PPO Type Non-Support Specifications
Frequency setting	Set the running frequency of the inverter.	50	76
Operation mode write	Set the operation mode of the inverter.	55	76
Run command	Set the control input command such as forward operation signal (STF) and reverse rotation signal (STR).	48	75
Inverter reset	Reset the inverter.	48, 56	74
Parameter write	Set parameters of the inverter.	46, 62	67, 78
Parameter clear	Return parameters to the initial values.	55	74
Input terminal function	Use the function of the inverter input terminal.	51	75

### REMARKS

- Refer to the *inverter manual* for functions controllable from the network in each operation mode.

# 6 PROFIBUS DEVICE DATA

## 6.1 Device data (GSD file)

melc08fa.gsd is a GSD file designed to recognize the features and functions of the PROFIBUS-DP devices of the FR-A7NP. You can obtain it from us.

GSD file can be downloaded from Mitsubishi Electric FA Network Service

MELFANS web: <http://www.MitsubishiElectric.co.jp/melfansweb> or obtained from your sales representative.

When editing this file, use a text editor.

For installation instructions, refer to the instruction manual of the PROFIBUS-DP Configuration Software.

Although this product complies with PPO type specification, it includes specifications which do not support PPO type specification (FR-E5NP intercompatibility protocol). This manual states the section supporting PPO type specification as "PPO type support specification" and the section not supporting PPO type as "PPO type non-support specification".

### CAUTION

- You cannot use the device data which does not include PPO type support specification (data for the FR-E5NP).

<melc08fa.gsd>

Parameter	Value	Description *1
#Profibus_DP		File header
GSD_Revision	1	ID version of GSD file
Vendor_Name	"Mitsubishi Electric"	Manufacturer name *2
Model_Name	"FR-A7NP"	Product name
Revision	"Revision 1.00"	Product version
Ident_Number	08FAH	Device number obtained from Profibus Nutzer Organization
Protocol_Ident	0	PROFIBUS-DP is 0 fixed.
Station_Type	0	DP slave is 0 fixed.

Parameter	Value	Description *1
FMS_Supp	0	FMS (Field-Bus Message Specifications) not supported.
Hardware_Release	"BC101B376"	Hardware version
Software_Release	"7732"	Software version
9.6_supp	1	Communication speed 9600bps support
19.2_supp	1	Communication speed 19.2Kbps support
93.75_supp	1	Communication speed 93.75Kbps support
187.5_supp	1	Communication speed 187.5Kbps support
500_supp	1	Communication speed 500Kbps support
1.5M_supp	1	Communication speed 1.5Mbps support
3M_supp	1	Communication speed 3.0Mbps support
6M_supp	1	Communication speed 6.0Mbps support
12M_supp	1	Communication speed 12.0Mbps support
MaxTsd_r_9.6	15	Longest time 15 bit times at communication speed 9600bps
MaxTsd_r_19.2	15	Longest time 15 bit times at communication speed 19.2Kbps
MaxTsd_r_93.75	15	Longest time 15 bit times at communication speed 93.75Kbps
MaxTsd_r_187.5	15	Longest time 15 bit times at communication speed 187.5Kbps
MaxTsd_r_500	15	Longest time 15 bit times at communication speed 500Kbps
MaxTsd_r_1.5M	25	Longest time 25 bit times at communication speed 1.5MKbps
MaxTsd_r_3M	50	Longest time 50 bit times at communication speed 3.0Mbps
MaxTsd_r_6M	100	Longest time 100 bit times at communication speed 6.0Mbps

Parameter	Value	Description *1
MaxTsdrr_12M	200	Longest time 200 bit times at communication speed 12.0Mbps
Redundancy	0	Redundancy not supported.
Repeater_Ctrl_Sig	2	Installed as TTL level via RTS signal from module.
24V_Pins	0	24V power supply for maintenance device connection is not used.
Freeze_Mode_supp	1	Freeze mode supported.
Sync_Mode_supp	1	Synchronous mode supported.
Auto_Baud_supp	1	Automatic baud rate detection support
Set_Slave_Add_supp	0	Slave address is not set.
Min_Slave_Intervall	1	100 µs interval between 2 polling cycles
Modular_Station	1	Modular device specified.
Max_Module	1	Maximum number of modules:1
Max_Input_Len	28	Input data: Maximum 28 bytes
Max_output_Len	28	Output data: Maximum 28 bytes
Max_Data_Len	56	Input and output data: Maximum 28 + 28 = 56 bytes
Fail_Safe	0	Failsafe not supported
Max_Diag_Data_Len	6	Diagnostic data of 6 bytes secured (no external diagnosis)
Slave_Family	1	Drives defined as function class (Main Family)
PrmText	1	Text selection 1 registration
Text(0)	"No byte swapping"	If Bit 0 = 0, "No byte swapping"
Text(1)	"Byte swapping"	If Bit 0 = 1, "Byte swapping"
EndPrmText		

Parameter	Value	Description *1
ExtUserPrmData	1 "Byte swapping"	Byte swapping selection 1 registration on text base
Bit(0) 0 0-1		Bit 0 = default 0, range 0 to 1
Prm_Text_Ref	1	Text selection 1 is used.
EndExtUserPrmData		
Max_User_Prm_Data_Len	2	User parameter of 2 bytes secured
Ext_User_Prm_Data_Const(0)	01H	Initial value of user parameter's 1 byte
Ext_User_Prm_Data_Const(1)	00H	Initial value of user parameter's 2 byte
Ext_User_Prm_Data_Ref(1)	1	Byte swapping selection 1 is used on text base in user parameter's 2 byte.
Module	"PPO type 1" F3H, F1H	PPO type 1 selection
EndModule		
Module	"PPO type 2" F3H, F5H	PPO type 2 selection
EndModule		
Module	"PPO type 3" F1H	PPO type 3 selection
EndModule		
Module	"PPO type 4" F5H	PPO type 4 selection
EndModule		
Module	"PPO type 5" F3H, F9H	PPO type 5 selection
EndModule		
Module	"500 series" 75H	FR-E5NP intercompatibility protocol selection
EndModule		

\*1 Description is not included in the ASCII file itself.

\*2 Use "Mitsubishi" if the maximum number of characters of the Vendor\_Name of the master used is 10.

## 6.2 Slave user parameter

By changing the slave user parameter value, you can use the byte swapping function (byte inversion function).

Setting "1" at Address 1H (Bit 0) makes the byte swapping function valid.  
 Since "-" is an unused bit, set "0".

Address	Functions							
0H	For manufacturer setting (Always set "1".)							
1H	Bit7	Bit6	Bit5	Bit4	Bit3	Bit2	Bit1	Bit0
	—	—	—	—	—	—	—	0:Byte swapping invalid 1:Byte swapping valid

### Example

- Byte swapping invalid (When address 1H (Bit0)=0)

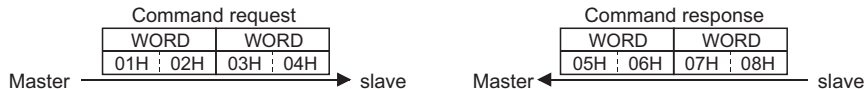

- Byte swapping valid (When address 1H (Bit0)=1)



The data is byte swapped in the slave to be a receiving/sending data.



# 7 PPO TYPE SUPPORT SPECIFICATION

## 7.1 PROFIBUS profiles

The option unit operates as a "slave of the PROFIBUS DP master" or a "controller equivalent to PROFIBUS DP master class 1 on an RS-485 network".

The PROFIBUS profile (data buffer) can be selected from among six different types, "PPO type1" to "PPO type5", and "E5NP". This chapter explains the profile of module type "PPO type1" to "PPO type5". (For the module type "E5NP" profile, refer to *Chapter 8*.)

Module type is changed with the slave module setting. For details, refer to *the instruction manual* of the Network Master Configuration Software. The configuration of PPO type is as follows.

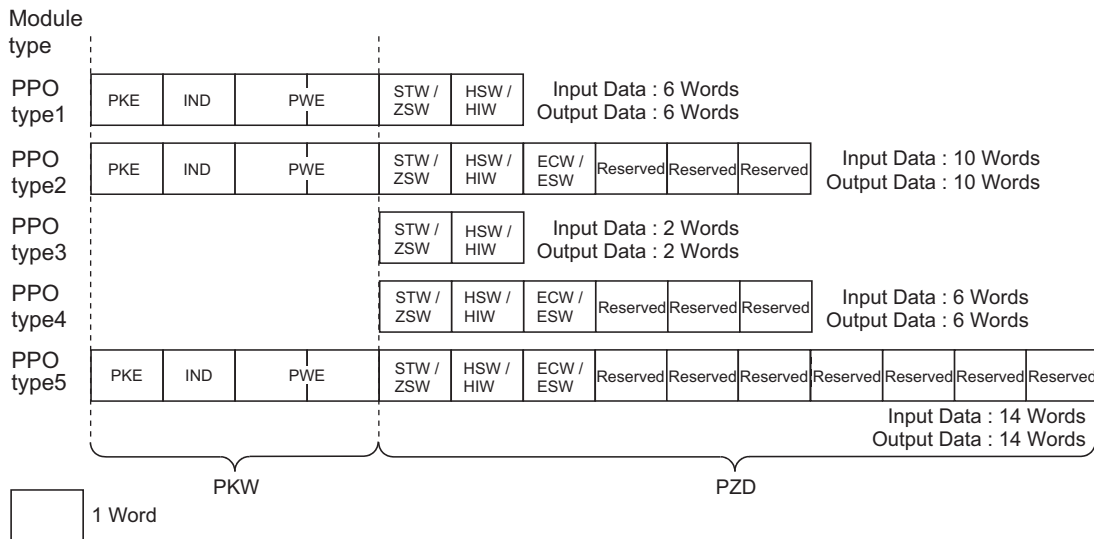

## 7.2 ID definitions

ID		Definition
PKW <i>(Refer to page 46)</i>	PKE	PNU number (PNU) and task or response Id (AK)
	IND	Sub-Index number and reserved area for extension
	PWE	<ul style="list-style-type: none"> <li>• Set 0 since high bits (Bits 16 to 31) are not used.</li> <li>• Low bits (Bits 0 to 15): Parameter value</li> </ul>
PZD <i>(Refer to page 48)</i>	STW/ZSW	STW: Control Word (Command request)*
		ZSW: Status Word (Command response)*
	HSW/HIW	HSW: Set frequency (Command request)*
		HIW: Output frequency (Command response)*
	ECW/ESW	ECW: Extended Control Word (Command request)*
		ECW: Extended Status Word (Command response)*
Reserved	Reserved area for extension	

\* Command request: Message from the master to the slave  
 Command response: Message from the slave to the master

## 7.3 Buffer memory map

The following shows the buffer memory map of the PPO type1 to PPO type5 PROFIBUS profiles.

Module type	1Word	2Word	3Word	4Word	5Word	6Word	7Word	8Word	9Word	10Word	11Word	12Word	13Word	14Word
PPO type1	PKE	IND	PWE	STW / ZSW	HSW / HIW									
PPO type2	PKE	IND	PWE	STW / ZSW	HSW / HIW	ECW / ESW	Reserved	Reserved	Reserved					
PPO type3	STW / ZSW	HSW / HIW												
PPO type4	STW / ZSW	HSW / HIW	ECW / ESW	Reserved	Reserved	Reserved								
PPO type5	PKE	IND	PWE	STW / ZSW	HSW / HIW	ECW / ESW	Reserved	Reserved	Reserved	Reserved	Reserved	Reserved	Reserved	Reserved

## 7.4 Buffer memory configuration

The buffer memory configuration is shown below.

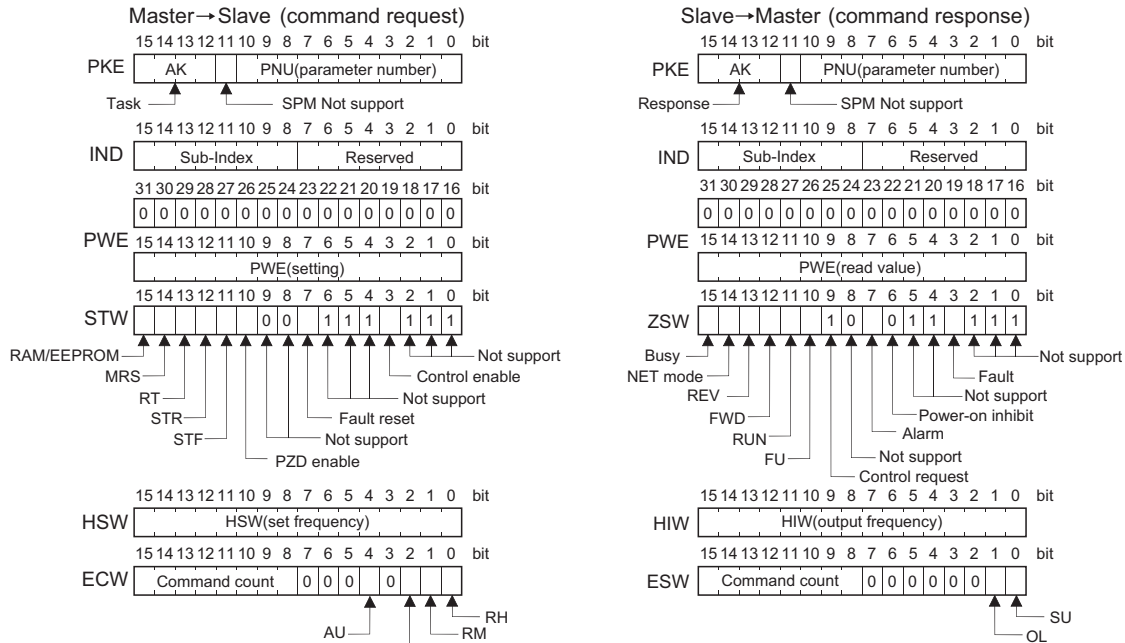

For buffer memory details, refer to *page 46*.

## 7.5 Buffer memory details

The following indicates the buffer memory details of the PROFIBUS profiles.

### (1) PKW

Name		Bit	Definition															
PKE	PNU	0 to 10	PNU number															
	SPM	11	Not used (0 is set)															
	AK	12 to 15	[Command request]															
			<table border="1"> <thead> <tr> <th>Value</th> <th>Operation</th> </tr> </thead> <tbody> <tr> <td>0</td> <td>No task</td> </tr> <tr> <td>1</td> <td>Parameter value is requested (read request)</td> </tr> <tr> <td>2</td> <td>Parameter value (word) is changed (write request)</td> </tr> <tr> <td>6</td> <td>Parameter value (array) is requested (read request)</td> </tr> <tr> <td>7</td> <td>Parameter value (array word) is changed (write request)</td> </tr> <tr> <td>Other than the above</td> <td>Non-supported</td> </tr> </tbody> </table>		Value	Operation	0	No task	1	Parameter value is requested (read request)	2	Parameter value (word) is changed (write request)	6	Parameter value (array) is requested (read request)	7	Parameter value (array word) is changed (write request)	Other than the above	Non-supported
			Value	Operation														
			0	No task														
			1	Parameter value is requested (read request)														
			2	Parameter value (word) is changed (write request)														
			6	Parameter value (array) is requested (read request)														
			7	Parameter value (array word) is changed (write request)														
Other than the above			Non-supported															
[Command response]																		
<table border="1"> <thead> <tr> <th>Value</th> <th>Operation</th> </tr> </thead> <tbody> <tr> <td>0</td> <td>No response (Busy status)</td> </tr> <tr> <td>1</td> <td>Parameter value (word) is transferred.</td> </tr> <tr> <td>4</td> <td>Parameter value (array word) is transferred.</td> </tr> <tr> <td>7</td> <td>Command execution error (error number is stored into PWE <i>(Refer to page 47)</i>)</td> </tr> <tr> <td>Other than the above</td> <td>Non-supported</td> </tr> </tbody> </table>		Value	Operation	0	No response (Busy status)	1	Parameter value (word) is transferred.	4	Parameter value (array word) is transferred.	7	Command execution error (error number is stored into PWE <i>(Refer to page 47)</i> )	Other than the above	Non-supported					
Value	Operation																	
0	No response (Busy status)																	
1	Parameter value (word) is transferred.																	
4	Parameter value (array word) is transferred.																	
7	Command execution error (error number is stored into PWE <i>(Refer to page 47)</i> )																	
Other than the above	Non-supported																	
IND	0 to 7	Reserved area for extension (0 is set)																
	8 to 15	Sub-Index number At command request, set this number when AK = "6, 7".																

Name	Bit	Definition																
PWE	0 to 15	<p>PNU read value/write value When command response AK = "7 (command execution error)", PWE definition is as follows.</p> <table border="1" data-bbox="426 249 1307 536"> <thead> <tr> <th data-bbox="426 249 535 280">Value</th> <th data-bbox="535 249 1307 280">Error Definition</th> </tr> </thead> <tbody> <tr> <td data-bbox="426 280 535 317">0</td> <td data-bbox="535 280 1307 317">Invalid PNU</td> </tr> <tr> <td data-bbox="426 317 535 353">1</td> <td data-bbox="535 317 1307 353">Parameter value unchangeable (This error also occurs when <i>Pr.77</i> = "1")</td> </tr> <tr> <td data-bbox="426 353 535 389">2</td> <td data-bbox="535 353 1307 389">Outside setting range</td> </tr> <tr> <td data-bbox="426 389 535 425">3</td> <td data-bbox="535 389 1307 425">Invalid Sub-Index number</td> </tr> <tr> <td data-bbox="426 425 535 462">4</td> <td data-bbox="535 425 1307 462">Without array</td> </tr> <tr> <td data-bbox="426 462 535 498">11</td> <td data-bbox="535 462 1307 498">No parameter change right</td> </tr> <tr> <td data-bbox="426 498 535 536">18</td> <td data-bbox="535 498 1307 536">Other error *</td> </tr> </tbody> </table> <p>* Indicates outside AK number range, write data error, external operation error, without option error, instruction code error, with STF error, with STR error, with operation mode specification error, parameter calibration error (<i>Pr. 900 or later</i>), reset disabled error (with reset input specification of <i>Pr. 75</i>), etc.</p>	Value	Error Definition	0	Invalid PNU	1	Parameter value unchangeable (This error also occurs when <i>Pr.77</i> = "1")	2	Outside setting range	3	Invalid Sub-Index number	4	Without array	11	No parameter change right	18	Other error *
	Value	Error Definition																
0	Invalid PNU																	
1	Parameter value unchangeable (This error also occurs when <i>Pr.77</i> = "1")																	
2	Outside setting range																	
3	Invalid Sub-Index number																	
4	Without array																	
11	No parameter change right																	
18	Other error *																	
16 to 31	Not used (0 is set)																	

## (2) PZD

Name		Bit	Definition	
STW	—	0 to 2	Not used (1 is set)	
	Control enable	3	0: Inverter output shutoff 1: Inverter output shutoff is cancelled	
	—	4 to 6	Not used (1 is set)	
	Fault reset (Reset)	7	[At inverter error] 0: No action 1: When Pr. 349 = "0", error reset can be made in any operation mode. When Pr. 349 = "1", error reset is enabled only in NET operation mode. [When inverter is normal] No action	
	—	8, 9	Not used (0 is set)	
	PZD enable	10	0: Command request of PZD is not processed. (Note that PZD enable and command count request can be executed.) 1: Command request of PZD is processed. * At power-on or inverter reset, set 1 once.	
	Forward rotation command (STF signal)	11	0: OFF (Stop command) 1: ON (Forward rotation start)	A starting command is input to the inverter when the signal turns on. A stop command is given when both signals turn on simultaneously.
	Reverse rotation command (STR signal)	12	0: OFF (Stop command) 1: ON (Reverse rotation start)	
	Second function selection (RT signal)	13	0: OFF 1: ON (Second function is selected)	
	Output stop (MRS signal)	14	0: OFF 1: ON (output is shut off)	
	RAM/EEPROM	15	0: Set frequency (HSW) is written to RAM (Power-on reset returns the changed set frequency to the setting before it was written to RAM.). 1: Set frequency (HSW) is written to EEPROM.	

Name		Bit	Definition
ZSW	—	0 to 2	Not used (1 is returned)
	Fault	3	0: Inverter normal 1: Inverter alarm occurrence
	—	4, 5	Not used (1 is returned)
	Power-on inhibit	6	0 is returned
	Alarm	7	0: Command execution normal 1: Command execution error
	—	8	Not used (0 is returned)
	Control request	9	1 is returned
	Output frequency detection (FU signal)	10	0: OFF 1: ON (output frequency being detected) (For details, refer to Pr. 42 and Pr.43 in the inverter manual.)
	Inverter running (RUN signal)	11	0: OFF 1: ON (inverter running)
	Forward running	12	0: Other than forward running (during stop, reverse running) 1: Forward running
	Reverse running	13	0: Other than reverse running (during stop, forward running) 1: Reverse running
NET mode	14	0: Other than network operation mode 1: Network operation mode	



Name		Bit	Definition										
ZSW	BUSY	15	0: Ready status 1: Busy status * * If it takes time to perform slave side processing, slave side busy status is announced since reply to the master will be delayed. During busy status, other response data are unfixed values. When the slave side is busy, request from the master is invalid. Therefore, the same request must be sent again. The response data of the FR-A7NP during Busy status is as follows.										
				<table border="1"> <thead> <tr> <th></th> <th>[During Busy status] and [inverter reset]</th> <th>[During Busy status] and [other than inverter rest]</th> </tr> </thead> <tbody> <tr> <td>PKW</td> <td>0</td> <td>All 0 when AK = 0 Reply data when AK ≠ 0</td> </tr> <tr> <td>PZD</td> <td>ZSW Bit15 = 1 Other error Bit = 0</td> <td>ZSW Bit15 = 1 Other error Bit = inverter status data</td> </tr> </tbody> </table>		[During Busy status] and [inverter reset]	[During Busy status] and [other than inverter rest]	PKW	0	All 0 when AK = 0 Reply data when AK ≠ 0	PZD	ZSW Bit15 = 1 Other error Bit = 0	ZSW Bit15 = 1 Other error Bit = inverter status data
				[During Busy status] and [inverter reset]	[During Busy status] and [other than inverter rest]								
			PKW	0	All 0 when AK = 0 Reply data when AK ≠ 0								
PZD	ZSW Bit15 = 1 Other error Bit = 0	ZSW Bit15 = 1 Other error Bit = inverter status data											
	HSW	0 to 15	Set frequency (0.01 Hz increments) (Always set frequency (Hz) regardless of the <i>Pr. 37</i> setting.)										
	HIW	0 to 15	Output frequency (0.01 Hz increments) (It is always displayed as frequency (Hz) regardless of the <i>Pr. 37</i> setting.)										

Name		Bit	Definition	
ECW	High speed operation command (Terminal RH function)	0	Functions assigned to terminal RH, RM, RL are activated. (Signal names are initial values. Using <i>Pr.180 to Pr.182</i> , you can change output signal functions. Refer to the inverter manual for details of <i>Pr.180 to Pr.182</i> .)	
	Middle-speed operation command (Terminal RM function)	1		
	Low-speed operation command (Terminal RL function)	2		
	—	3		Not used (0 is set)
	Terminal 4 input selection (AU signal)	4		0: OFF 1: ON (Terminal 4 input is the main speed setting)
	—	5 to 7		Not used (0 is set)
	Command count	8 to 15		Used by the master to recognize the command response.
ESW	Up to frequency (SU signal)	0	0: OFF 1: ON (Output frequency has reached the set frequency)	
	Overload alarm (OL signal)	1	0: OFF 1: ON (Overload alarm occurrence)	
	—	2 to 7	Not used (0 is set)	
	Command count	8 to 15	Echo back of the command request.	
Reserved		0 to 15	Not used (0 is set, 0 is returned)	

---

### **CAUTION**

---

- Only when the contents of the command request (request for changing the inverter setting: PKW, HSW, STW/ECW) from the master changed, the inverter processes the request. If the contents of the command request are identical with those of the last request, the inverter does not process the request. (The received request is cleared.)

For instance, while the master keeps sending the "network operation mode enabled" command, changing the mode to the PU operation mode with switchover function does not allow the "network operation mode enabled" command to be executed due to the same contents as that sent last time. Therefore, the operation mode remains the PU operation mode without changing to the Network operation mode. In this case, send another command as "PU operation mode enabled" from the master once, then send the "network operation mode enabled" command again.

---

---

## 7.6 Outline of PNU

You can use the PNU to make inverter settings from the network.  
 The data used with the network is denoted PNU(P) to differentiate it from the parameter (Pr.).  
 This chapter explains the module type "PPO type 1" to "PPO type 5".

### CAUTION

• Parameter definitions differ according to the module type selected. When using "E5NP", refer to *page 72*.

#### (1) PNU data definition

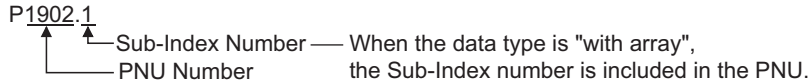

#### (2) PNU data type

The PNU has the data types of "Array Unsigned 16 (AUs16)" and "Unsigned 16 (Us16)".

Array Unsigned 16 (AUs16)	
P1902.1 	With array
Unsigned 16 (Us16)	
P1240	Without array

### CAUTION

• When the data type is "with array", include the sub-index number in the PNU.

## 7.7 PROFIBUS PNU

### 7.7.1 Real-time monitor

The following items can be monitored from the master.

PNU	Item	Increments	Data Type
P1.1	Output frequency	0.01Hz	AUs16
P1.2	Output current	0.01A	AUs16
P1.3	Output voltage	0.1V	AUs16
P1.5	Frequency setting	0.01Hz	AUs16
P1.7	Motor torque	0.1%	AUs16
P1.8	Converter output voltage	0.1V	AUs16
P1.9	Regenerative brake duty	0.1%	AUs16
P1.10	Electronic thermal relay function load factor	0.1%	AUs16
P1.11	Output current peak value	0.01A	AUs16
P1.12	Converter output voltage peak value	0.1V	AUs16
P1.14	Output power	0.01kW	AUs16

PNU	Item	Increments	Data Type
P1.15	Input terminal status *1	—	AUs16
P1.16	Output terminal status *2	—	AUs16
P1.20	Cumulative energization time	1h	AUs16
P1.23	Actual operation time	1h	AUs16
P1.24	Motor load factor	0.1%	AUs16
P1.25	Cumulative power	1kWh	AUs16
P1.52	PID set point	0.1%	AUs16
P1.53	PID measurement value	0.1%	AUs16
P1.54	PID deviation	0.1%	AUs16
P1.61	Motor thermal load factor	0.1%	AUs16
P1.62	Inverter thermal load factor	0.1%	AUs16
P1.63	Cumulative power 2	0.01kWh	AUs16

\*1 Input terminal monitor details

b15

—	—	—	—	—	RES	—	MRS	—	RH	RM	RL	—	—	STR	STF
---	---	---	---	---	-----	---	-----	---	----	----	----	---	---	-----	-----

Functions of each terminal are assigned using Pr.178 to Pr.184. (Refer to the inverter manual for details.)

\*2 Output terminal monitor details

b15

—	—	—	—	—	—	—	—	—	—	ABC	FU	—	—	—	RUN
---	---	---	---	---	---	---	---	---	---	-----	----	---	---	---	-----

Functions of each terminal are assigned using Pr.190 to Pr.192. (Refer to the inverter manual for details.)

### 7.7.2 Parameter clear

Parameter clear can be performed from the master.

PNU	Item	Data Definition	Data Type
P2.2	Parameter clear	965AH	AUs16
P2.3	All parameter clear	99AAH	AUs16
P2.5	Parameter clear*	5A96H	AUs16
P2.6	All parameter clear*	AA99H	AUs16
P2.8	Error history clear	0000H	AUs16

\* Communication parameters (*Pr. 117 to Pr. 124, Pr. 338 to Pr. 340, Pr. 343, Pr. 349, Pr. 549 to Pr. 551*) are not cleared.

### 7.7.3 Operation mode read/write

Read/write of the operation mode can be performed from the master.

PNU	Item	Data Definition	Data Type
P3	Operation mode read/write	External operation mode:10H PU operation mode:11H ( <i>Pr. 79</i> = "6") Network operation mode:14H	Us16

### 7.7.4 Set frequency read

The frequency set to the inverter can be read from the master.

PNU	Item	Data Definition	Data Type
P4.1	Set frequency (RAM) read*	Set frequency (RAM) is read.	AUs16
P4.2	Set frequency (EEPROM) read*	Set frequency (EEPROM) is read.	AUs16

\* It is always displayed as frequency (Hz) regardless of the *Pr. 37* setting.

### 7.7.5 Terminal input read

Analog input values of terminals 2 and 4 can be read.

PNU	Item	Data Definition	Data Type
P5.1	Terminal 2 input value read	Terminal 2 input value (%) is read.	AUs16
P5.2	Terminal 4 input value read	Terminal 4 input value (%) is read.	AUs16

### 7.7.6 Inverter reset

The inverter can be reset from the master.

PNU	Item	Data Definition	Data Type
P6	Inverter reset	The inverter is reset after the data was written from the master.	Us16

- The inverter maintains the resetting status while reset is requested.
- When  $Pr.75 = "1, 3, 15, 17"$ , reset is enabled only during an inverter error.

### 7.7.7 Node address read

The node address of the inverter can be read.

PNU	Item	Data Definition	Data Type
P918	Node address read	Set node address is read.	Us16

### 7.7.8 Fault records read

(1) Fault records of past eight faults occurred in the inverter can be read. (Refer to page 58 for error number.)

PNU	Item	Data Definition	Data Type
P947.1 to P947.8	Latest fault is read	P947.1 :error number P947.2 to P947.8 :all 0	AUs16
P947.9 to P947.16	Second fault in past is read	P947.9 :error number P947.10 to P947.16 :all 0	AUs16
P947.17 to P947.24	Third fault in past is read	P947.17 :error number P947.18 to P947.24 :all 0	AUs16
P947.25 to P947.32	Forth fault in past is read	P947.25 :error number P947.26 to P947.32 :all 0	AUs16
P947.33 to P947.40	Fifth fault in past is read	P947.33 :error number P947.34 to P947.40 :all 0	AUs16
P947.41 to P947.48	Sixth fault in past is read	P947.41 :error number P947.42 to P947.48 :all 0	AUs16
P947.49 to P947.56	Seventh fault in past is read	P947.49 :error number P947.50 to P947.56 :all 0	AUs16
P947.57 to P947.64	Eighth fault in past is read	P947.57 :error number P947.58 to P947.64 :all 0	AUs16



<Fault data>

Refer to *the inverter manual* for details of fault definitions.

Error Number	Definition
00H	No fault present
10H	E.OC1
11H	E.OC2
12H	E.OC3
20H	E.OV1
21H	E.OV2
22H	E.OV3
30H	E.THT
31H	E.THM
40H	E.FIN
52H	E.ILF
60H	E.OLT
70H	E.BE
80H	E.GF
81H	E.LF
90H	E.OHT
A1H	E.OP1

Error Number	Definition
B0H	E.PE
B1H	E.PUE
B2H	E.RET
B3H	E.PE2
C0H	E.CPU
C5H	E.IOH
C7H	E.AIE
C8H	E.USB
D8H	E.MB4
D9H	E.MB5
DAH	E.MB6
DBH	E.MB7
F1H	E. 1
F5H	E. 5
F6H	E. 6
F7H	E. 7
FDH	E. 13

(2) Energization time (fault monitor) for past eight faults at the inverter fault occurrence can be read.

<b>PNU</b>	<b>Item</b>	<b>Data Definition</b>	<b>Data Type</b>
P948.1 to P948.8	Latest fault monitor energization time read	P948.1 :energization time P948.2 to P948.8 :all 0	AUs16
P948.9 to P948.16	Energization time of second fault monitor in past read	P948.9 :energization time P948.10 to P948.16 :all 0	AUs16
P948.17 to P948.24	Energization time of third fault monitor in past read	P948.17 :energization time P948.18 to P948.24 :all 0	AUs16
P948.25 to P948.32	Energization time of forth fault monitor in past read	P948.25 :energization time P948.26 to P948.32 :all 0	AUs16
P948.33 to P948.40	Energization time of fifth fault monitor in past read	P948.33 :energization time P948.34 to P948.40 :all 0	AUs16
P948.41 to P948.48	Energization time of sixth fault monitor in past read	P948.41 :energization time P948.42 to P948.48 :all 0	AUs16
P948.49 to P948.56	Energization time of seventh fault monitor in past read	P948.49 :energization time P948.50 to P948.56 :all 0	AUs16
P948.57 to P948.64	Energization time of eighth fault monitor in past read	P948.57 :energization time P948.58 to P948.64 :all 0	AUs16

(3) Output frequency, output current and output voltage for past eight faults at the inverter fault occurrence can be read.

<b>PNU</b>	<b>Item</b>	<b>Data Definition</b>	<b>Data Type</b>
P949.1 to P949.8	Latest fault monitor frequency, current and voltage read	P949.1 :output frequency P949.2 :output current P949.3 :output voltage P949.4 to P949.8 :all 0	AUs16
P949.9 to P949.16	Second fault monitor frequency, current and voltage in past read	P949.9 :output frequency P949.10 :output current P949.11 :output voltage P949.12 to P949.16 :all 0	AUs16
P949.17 to P949.24	Third fault monitor frequency, current and voltage in past read	P949.17 :output frequency P949.18 :output current P949.19 :output voltage P949.20 to P949.24 :all 0	AUs16
P949.25 to P949.32	Forth fault monitor frequency, current and voltage in past read	P949.25 :output frequency P949.26 :output current P949.27 :output voltage P949.28 to P949.32 :all 0	AUs16
P949.33 to P949.40	Fifth fault monitor frequency, current and voltage in past read	P949.33 :output frequency P949.34 :output current P949.35 :output voltage P949.36 to P949.40 :all 0	AUs16
P949.41 to P949.48	Sixth fault monitor frequency, current and voltage in past read	P949.41 :output frequency P949.42 :output current P949.43 :output voltage P949.44 to P949.48 :all 0	AUs16
P949.49 to P949.56	Seventh fault monitor frequency, current and voltage in past read	P949.49 :output frequency P949.50 :output current P949.51 :output voltage P949.52 to P949.56 :all 0	AUs16
P949.57 to P949.64	Eighth fault monitor frequency, current and voltage in past read	P949.57 :output frequency P949.58 :output current P949.59 :output voltage P949.60 to P949.64 :all 0	AUs16

### 7.7.9 PNU list read

The usable PNU numbers can be read.

PNU	Item	Data Definition	Data Type
P980.1 to 116 P981.1 to 116 P982.1 to 116 P983.1 to 116 P984.1 to 116 P985.1 to 116 P986.1 to 116 P987.1 to 116 P988.1 to 116 P989.1 to 116	PNU list read	Usable PNU numbers are read in sorted status.	AUs16

PNU list read example

PNU	Usable PNU number	REMARKS
P980.1	1	Inverter command parameter
P980.2	2	
P980.3	3	
⋮	⋮	
P980.116	1000	Inverter standard parameter
P981.1	1001	
P981.2	1002	
⋮	⋮	
P982.111	0*	

\* When 0 is stored, read is terminated.

## 7.8 Standard parameters

You can use the PNU to make parameter settings from the network.

The table below lists PNU numbers corresponding to parameter numbers.

Standard parameter examples are introduced below. Refer to the examples and make parameter settings. Refer to *the inverter manual* for details of the parameters.

Representation of the PNU for standard parameters (Example: Pr.902)



### Example of parameter list

Parameter Number	PNU	Name	Minimum Setting Increments	Setting Range		Data Type
				Decimal	Hexadecimal	
0	P1000	Torque boost	0.1%	0 to 30	0 to 12C	Us16
1	P1001	Maximum frequency	0.01Hz	0 to 120	0 to 2EE0	Us16
2	P1002	Minimum frequency	0.01Hz	0 to 120	0 to 2EE0	Us16
3	P1003	Base Frequency	0.01Hz	0 to 400	0 to 9C40	Us16
4	P1004	Multi-speed setting (high speed)	0.01Hz	0 to 400	0 to 9C40	Us16
5	P1005	Multi-speed setting (middle speed)	0.01Hz	0 to 400	0 to 9C40	Us16
6	P1006	Multi-speed setting (low speed)	0.01Hz	0 to 400	0 to 9C40	Us16
⋮	⋮	⋮	⋮	⋮	⋮	⋮

### CAUTION

Write to Pr. 77 and Pr. 79 is not allowed from the network with FR-A7NP. (Read is allowed.)

The following parameters require the sub-index number for the PNU.

Parameter Number	PNU	Name	Minimum Setting Increments	Setting Range		Data Type
				Decimal	Hexadecimal	
900	P1900.1	FM terminal calibration *1	—	—	—	AUs16
901	P1901.1	AM terminal calibration *2	—	—	—	AUs16
902	P1902.1	Terminal 2 frequency setting bias frequency	0.01Hz	0 to 400	0 to 9C40	AUs16
	P1902.2	Terminal 2 frequency setting bias	0.1%	0 to 300	0 to BB8	AUs16
903	P1903.1	Terminal 2 frequency setting gain frequency	0.01Hz	0 to 400	0 to 9C40	AUs16
	P1903.2	Terminal 2 frequency setting gain	0.1%	0 to 300	0 to BB8	AUs16
904	P1904.1	Terminal 4 frequency setting bias frequency	0.01Hz	0 to 400	0 to 9C40	AUs16
	P1904.2	Terminal 4 frequency setting bias	0.1%	0 to 300	0 to BB8	AUs16
905	P1905.1	Terminal 4 frequency setting gain frequency	0.01Hz	0 to 400	0 to 9C40	AUs16
	P1905.2	Terminal 4 frequency setting gain	0.1%	0 to 300	0 to BB8	AUs16
922	P1922.1	Frequency setting voltage bias frequency (built-in potentiometer) *1	0.01Hz	0 to 400	0 to 9C40	AUs16
	P1922.2	Frequency setting voltage bias (built-in potentiometer) *1	0.1%	0 to 300	0 to BB8	AUs16
923	P1923.1	Frequency setting voltage gain frequency (built-in potentiometer) *1	0.01Hz	0 to 400	0 to 9C40	AUs16
	P1923.2	Frequency setting voltage gain (built-in potentiometer) *1	0.1%	0 to 300	0 to BB8	AUs16

\*1 These parameters can be set for the Japanese version only.

\*2 This parameter can be set for the NA, EC and CH versions only.



## 8.2 ID definitions

ID		Definition
PKW <i>(Refer to page 67)</i>	PKE	PNU number (PNU) and task or response Id (AK)
	IND	Index number
	PWE	<ul style="list-style-type: none"> <li>• Set 0 since high bits (Bits 16 to 31) are not used.</li> <li>• Lower (Bits 0 to 15): Parameter value</li> </ul>
PZD <i>(Refer to page 70)</i>	ZSW	<ul style="list-style-type: none"> <li>• Bits 0 to 7: Inverter status (Command response)</li> <li>• Set 0 since Bits 8 to 15 are not used.</li> </ul>
	HIW	Reserved area for extension

\* Command request: Message from the master to the slave  
 Command response: Message from the slave to the master

## 8.3 Buffer memory map

The following shows the buffer memory map of the E5NP PROFIBUS profiles.

Module type	1 Word	2 Words	3 Words	4 Words	5 Words	6 Words
E5NP	PKE	IND	PWE		Reserved/ HIW	Reserved/ ZSW



## 8.4 Buffer memory configuration

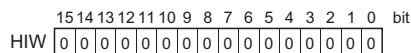
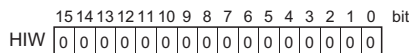
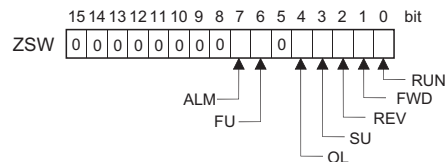
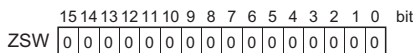
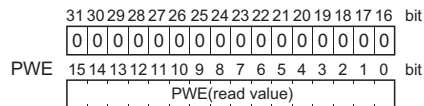
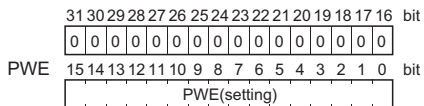
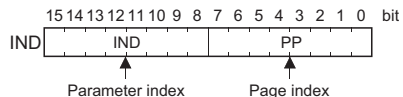
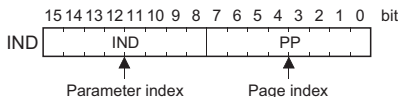
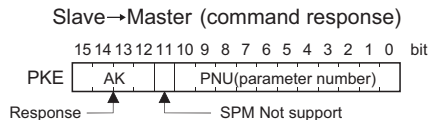
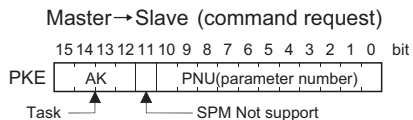

For buffer memory details, refer to *page 67*.

## 8.5 Buffer memory details

The following indicates the buffer memory details of the PROFIBUS profiles.

### (1) PKW

Name		Bit	Definition												
PKE	PNU	0 to 10	PNU number (Together, the PNU and the IND define which data word is being accessed.)												
	SPM	11	Not used (0 is set)												
	AK	12 to 15	[Command request]												
			<table border="1"> <thead> <tr> <th>Value</th> <th>Operation</th> </tr> </thead> <tbody> <tr> <td>0</td> <td>No task</td> </tr> <tr> <td>1</td> <td>Parameter value is requested (read request)</td> </tr> <tr> <td>2</td> <td>Parameter value (word) is changed (write request)</td> </tr> <tr> <td>Other than the above</td> <td>Non-supported</td> </tr> </tbody> </table>		Value	Operation	0	No task	1	Parameter value is requested (read request)	2	Parameter value (word) is changed (write request)	Other than the above	Non-supported	
			Value	Operation											
			0	No task											
			1	Parameter value is requested (read request)											
			2	Parameter value (word) is changed (write request)											
			Other than the above	Non-supported											
			[Command response]												
<table border="1"> <thead> <tr> <th>Value</th> <th>Operation</th> </tr> </thead> <tbody> <tr> <td>0</td> <td>No response (Busy status)</td> </tr> <tr> <td>1</td> <td>Inverter can accept data (Ready status)</td> </tr> <tr> <td>7</td> <td>Command execution error (error number is stored into PWE (<i>Refer to page 69.</i>))</td> </tr> <tr> <td>8</td> <td>No operation change rights</td> </tr> <tr> <td>Other than the above</td> <td>Not used</td> </tr> </tbody> </table>			Value	Operation	0	No response (Busy status)	1	Inverter can accept data (Ready status)	7	Command execution error (error number is stored into PWE ( <i>Refer to page 69.</i> ))	8	No operation change rights	Other than the above	Not used	
Value			Operation												
0	No response (Busy status)														
1	Inverter can accept data (Ready status)														
7	Command execution error (error number is stored into PWE ( <i>Refer to page 69.</i> ))														
8	No operation change rights														
Other than the above	Not used														
[Command response]															
<table border="1"> <thead> <tr> <th>Value</th> <th>Operation</th> </tr> </thead> <tbody> <tr> <td>0</td> <td>No response (Busy status)</td> </tr> <tr> <td>1</td> <td>Inverter can accept data (Ready status)</td> </tr> <tr> <td>7</td> <td>Command execution error (error number is stored into PWE (<i>Refer to page 69.</i>))</td> </tr> <tr> <td>8</td> <td>No operation change rights</td> </tr> <tr> <td>Other than the above</td> <td>Not used</td> </tr> </tbody> </table>		Value	Operation	0	No response (Busy status)	1	Inverter can accept data (Ready status)	7	Command execution error (error number is stored into PWE ( <i>Refer to page 69.</i> ))	8	No operation change rights	Other than the above	Not used		
Value	Operation														
0	No response (Busy status)														
1	Inverter can accept data (Ready status)														
7	Command execution error (error number is stored into PWE ( <i>Refer to page 69.</i> ))														
8	No operation change rights														
Other than the above	Not used														
[Command response]															
<table border="1"> <thead> <tr> <th>Value</th> <th>Operation</th> </tr> </thead> <tbody> <tr> <td>0</td> <td>No response (Busy status)</td> </tr> <tr> <td>1</td> <td>Inverter can accept data (Ready status)</td> </tr> <tr> <td>7</td> <td>Command execution error (error number is stored into PWE (<i>Refer to page 69.</i>))</td> </tr> <tr> <td>8</td> <td>No operation change rights</td> </tr> <tr> <td>Other than the above</td> <td>Not used</td> </tr> </tbody> </table>		Value	Operation	0	No response (Busy status)	1	Inverter can accept data (Ready status)	7	Command execution error (error number is stored into PWE ( <i>Refer to page 69.</i> ))	8	No operation change rights	Other than the above	Not used		
Value	Operation														
0	No response (Busy status)														
1	Inverter can accept data (Ready status)														
7	Command execution error (error number is stored into PWE ( <i>Refer to page 69.</i> ))														
8	No operation change rights														
Other than the above	Not used														

Name		Bit	Definition
IND	PP	0 to 7	<p>Page Index :</p> <ul style="list-style-type: none"> <li>If IND = 1 (system environment variable (sev) area ), the PP values specify different blocks of sev's: <ul style="list-style-type: none"> <li>PP = 0 : sev_I, block I</li> <li>PP = 1 : sev_II, block II (alarm history)</li> <li>PP = 2 : sev_III, block III</li> </ul> </li> </ul> <p>(For details, refer to <i>page 74.</i>)</p> <ul style="list-style-type: none"> <li>If IND is other than 1 (system environment variable (sev) area), set PP to 0.</li> </ul>
	IND	8 to 15	<p>Parameter Index :</p> <p>Specifies the area from which Parameter Number (PNU) is being accessed. (For details, refer to <i>page 73.</i>)</p> <ul style="list-style-type: none"> <li>IND = 0: real-time monitor area</li> <li>IND = 1: system environment variable (sev) area (3 blocks)</li> <li>IND = 2: normal parameter area</li> <li>IND = 3: <i>Pr. 900 to</i> calibration parameter (frequency) area</li> <li>IND = 4: <i>Pr. 900 to</i> calibration parameter (%) area</li> </ul>

Name	Bit	Definition																																					
PWE	0 to 15	PNU read value/write value When command response AK = "7 (command execution error)", PWE definition is as follows.																																					
		<table border="1"> <thead> <tr> <th data-bbox="441 236 690 270">Value</th> <th data-bbox="690 236 1275 270">Error Definition</th> </tr> </thead> <tbody> <tr> <td data-bbox="441 270 690 311">0</td> <td data-bbox="690 270 1275 311">Without error</td> </tr> <tr> <td data-bbox="441 311 690 346">1</td> <td data-bbox="690 311 1275 346">Unsupported task (includes writing)</td> </tr> <tr> <td data-bbox="441 346 690 380">2</td> <td data-bbox="690 346 1275 380">Invalid Parameter Index (IND)</td> </tr> <tr> <td data-bbox="441 380 690 414">3</td> <td data-bbox="690 380 1275 414">Invalid PNU</td> </tr> <tr> <td data-bbox="441 414 690 448">6</td> <td data-bbox="690 414 1275 448">Invalid Page Index (PP)</td> </tr> <tr> <td data-bbox="441 448 690 482">65</td> <td data-bbox="690 448 1275 482">Mode error</td> </tr> <tr> <td data-bbox="441 482 690 516">66</td> <td data-bbox="690 482 1275 516">Instruction code error</td> </tr> <tr> <td data-bbox="441 516 690 551">67</td> <td data-bbox="690 516 1275 551">Data setting range error</td> </tr> </tbody> </table>	Value	Error Definition	0	Without error	1	Unsupported task (includes writing)	2	Invalid Parameter Index (IND)	3	Invalid PNU	6	Invalid Page Index (PP)	65	Mode error	66	Instruction code error	67	Data setting range error	<table border="1"> <thead> <tr> <th data-bbox="441 236 690 270">Value</th> <th data-bbox="690 236 1275 270">Error Definition</th> </tr> </thead> <tbody> <tr> <td data-bbox="441 270 690 311">0</td> <td data-bbox="690 270 1275 311">Without error</td> </tr> <tr> <td data-bbox="441 311 690 346">1</td> <td data-bbox="690 311 1275 346">Unsupported task (includes writing)</td> </tr> <tr> <td data-bbox="441 346 690 380">2</td> <td data-bbox="690 346 1275 380">Invalid Parameter Index (IND)</td> </tr> <tr> <td data-bbox="441 380 690 414">3</td> <td data-bbox="690 380 1275 414">Invalid PNU</td> </tr> <tr> <td data-bbox="441 414 690 448">6</td> <td data-bbox="690 414 1275 448">Invalid Page Index (PP)</td> </tr> <tr> <td data-bbox="441 448 690 482">65</td> <td data-bbox="690 448 1275 482">Mode error</td> </tr> <tr> <td data-bbox="441 482 690 516">66</td> <td data-bbox="690 482 1275 516">Instruction code error</td> </tr> <tr> <td data-bbox="441 516 690 551">67</td> <td data-bbox="690 516 1275 551">Data setting range error</td> </tr> </tbody> </table>	Value	Error Definition	0	Without error	1	Unsupported task (includes writing)	2	Invalid Parameter Index (IND)	3	Invalid PNU	6	Invalid Page Index (PP)	65	Mode error	66	Instruction code error	67	Data setting range error
		Value	Error Definition																																				
		0	Without error																																				
		1	Unsupported task (includes writing)																																				
		2	Invalid Parameter Index (IND)																																				
		3	Invalid PNU																																				
		6	Invalid Page Index (PP)																																				
		65	Mode error																																				
		66	Instruction code error																																				
67	Data setting range error																																						
Value	Error Definition																																						
0	Without error																																						
1	Unsupported task (includes writing)																																						
2	Invalid Parameter Index (IND)																																						
3	Invalid PNU																																						
6	Invalid Page Index (PP)																																						
65	Mode error																																						
66	Instruction code error																																						
67	Data setting range error																																						
16 to 31	Not used (0 is set)																																						

## (2) PZD

Name		Bit	Definition
ZSW	Inverter running (RUN signal)	0	0 : OFF 1 : ON (inverter running)
	Forward running	1	0 : Other than forward running (during stop or reverse rotation) 1 : Forward running
	Reverse running	2	0 : Other than reverse running (during stop or forward rotation) 1 : Reverse running
	Up to frequency (SU signal)	3	0 : OFF 1 : ON (up to frequency)
	Overload alarm (OL signal)	4	0 : OFF 1 : ON (overload alarm)
	—	5	Not used (0 is returned)
	Output frequency detection (FU signal)	6	0 : OFF 1 : ON (output frequency being detected)
	Fault output (ALM signal)	7	0 : Inverter normal 1 : Inverter alarm occurrence
—	8 to 15	Not used (0 is returned)	<ul style="list-style-type: none"> <li>• For master-to-slave messages (command request), bits 0 to 7 are not used and must be set to 0. The bit-wise data here do not reflect <i>Pr.190 to Pr.192 (output terminal function selection)</i>.</li> <li>• At command response, signals are the same. Signals are not affected by settings of <i>Pr.190 to Pr.192 (output terminal function selection)</i>.</li> </ul>
HIW	0 to 15	Not used (0 is set)	

---

---

**CAUTION**

---

---

- Only when the contents of the command request (request for changing the inverter setting: PKW) from the master changed, the inverter processes the request. If the contents of the command request are identical with those of the last request, the inverter does not process the request. (The received request is cleared.)

For instance, while the master keeps sending the "network operation mode enabled" command, changing the mode to the PU operation mode with switchover function does not allow the "network operation mode enabled" command to be executed due to the same contents as that sent last time. Therefore, the operation mode remains the PU operation mode without changing to the Network operation mode.

In this case, send another command as "PU operation mode enabled" from the master once, then send the "network operation mode enabled" command again.

---

---

### **8.6 Outline of PNU**

---

You can use the PNU to make inverter settings from the network.  
The data used with the network is denoted PNU(P) to differentiate it from the parameter (Pr.).  
This chapter explains the module type "E5NP".

---

#### **CAUTION**

---

- **Parameter definitions differ according to the module type selected. When using "PPO type1" to "PPO type5", refer to *page 53*.**
- 
-

## 8.7 PROFIBUS PNU (Module type E5NP)

### 8.7.1 Real-time monitor area (IND=0000H (IND=00H, PP=00H))

The following items can be monitored from the master.

IND	PNU	Item	Increments
0000H	0H	Output frequency	0.01Hz
0000H	1H	Output current	0.01A
0000H	2H	Output voltage	0.1V
0000H	4H	Frequency setting	0.01Hz
0000H	6H	Motor torque	0.1%
0000H	7H	Converter output voltage	0.1V
0000H	8H	Regenerative brake duty	0.1%
0000H	9H	Electronic thermal relay function load factor	0.1%
0000H	AH	Output current peak value	0.01A
0000H	BH	Converter output voltage peak value	0.1V
0000H	DH	Output power	0.01kW

IND	PNU	Item	Increments
0000H	EH	Input terminal status *1	—
0000H	FH	Output terminal status *2	—
0000H	13H	Cumulative energization time	1h
0000H	16H	Actual operation time	1h
0000H	17H	Motor load factor	0.1%
0000H	18H	Cumulative power	1kWh
0000H	33H	PID set point	0.1%
0000H	34H	PID measured value	0.1%
0000H	35H	PID deviation	0.1%
0000H	3CH	Motor thermal load factor	0.1%
0000H	3DH	Inverter thermal load factor	0.1%
0000H	3EH	Cumulative power 2	0.01kWh

#### \*1 Input terminal monitor details

b15											b0				
—	—	—	—	—	RES	—	MRS	—	RH	RM	RL	—	—	STR	STF

Functions of each terminal are assigned using Pr.178 to Pr.184. (Refer to the inverter manual for details)

#### \*2 Output terminal monitor details

b15											b0				
—	—	—	—	—	—	—	—	—	—	ABC	FU	—	—	—	RUN

Functions of each terminal are assigned using Pr.190 to Pr.192. (Refer to the inverter manual for details)



**8.7.2 System environment variable (sev) area (IND = 01PPH (IND = 01H, PP = 00H, 01H))****● sev Interface (IND = 01H, PP = 00H, sev\_I, block I)****(1) Parameter clear**

Parameter clear can be performed from the master.

IND	PNU	Item	Data Definition
0100H	1H	Inverter reset	
0100H	2H	Parameter clear	965AH
0100H	3H	All parameter clear	99AAH
0100H	5H	Parameter clear *	5A96H
0100H	6H	All parameter clear *	AA99H

\* Communication parameters (Pr. 117 to Pr. 124, Pr. 338 to Pr.340, Pr.343, Pr. 349, Pr.549 to Pr.551) are not cleared.

(2) Inverter status/operation command

The inverter status can be monitored and operation command can be given from the master.

IND	PNU	Item			
0100H	AH	<ul style="list-style-type: none"> <li>Inverter status Refer to ZSW on <i>page 70</i> for details.</li> <li>Run command</li> </ul>			
		<b>Bit</b>	<b>Name</b>	<b>Definition</b>	
		1	Forward rotation command (STF signal)	0: OFF (Stop command) 1: ON (Forward rotation start)	A starting command is input to the inverter when the signal turns ON. A stop command is given when both signals turn ON simultaneously.
		2	Reverse rotation command (STR signal)	0: OFF (Stop command) 1: ON (Reverse rotation start)	
		3	High-speed operation command (terminal RH function) *1	Functions assigned to terminals RH, RM and RL are activated.	
		4	Middle-speed operation command (terminal RM function) *1		
		5	Low-speed operation command (terminal RL function) *1		
		7	Second function selection (RT signal)	1: Second function is selected	
		8	Terminal 4 input selection (AU signal)	1: Terminal 4 input is the main speed setting	
		10	Output stop (terminal MRS function) *1	Functions assigned to terminal MRS is activated.	
12	Inverter reset (terminal RES function) *1	Functions assigned to terminal RES is activated. *2			
Other than the above	–	Not used (0 is set)			
		*1 Signal names are initial values. Using <i>Pr. 180 to Pr. 184</i> , you can change output signal functions. Refer to the inverter manual for details of <i>Pr. 180 to Pr. 184</i> .			
		*2 Inverter reset function is invalid.			

### (3) Operation mode write

Write of the operation mode can be performed from the master.

IND	PNU	Item	Data Definition
0100H	BH	Operation mode	External operation mode:10H PU operation mode:11H (When Pr.79 = "6") Network operation mode:14H

### (4) Set frequency read/write

The frequency set to the inverter can be read/written from the master.

IND	PNU	Item	Data Definition
0100H	DH	Set frequency (RAM) *1	Set frequency (RAM) is read or written.
0100H	EH	Set frequency (EEPROM) *1,2	Write set frequency to EEPROM.

\*1 Writing to PNU = DH or PNU = EH can be read out from PNU = DH.

\*2 To change the running frequency consecutively, always write data to the inverter RAM.

### (5) Terminal input read

The analog input values of terminals 2 and 4 can be read.

IND	PNU	Name	Minimum Setting Increments
0100H	FH	Terminal 2 input value read	0.1%
0100H	10H	Terminal 4 input value read	0.1%

● **Faults History (IND = 01H, PP = 01H, sev\_II, block II)**

The past eight inverter fault records can be read.

IND	PNU	Item	IND	PNU	Item
0101H	0H	Latest fault *1	0101H	4H	Fifth fault in past is read
0101H	1H	Second fault in past is read	0101H	5H	Sixth fault in past is read
0101H	2H	Third fault in past is read	0101H	6H	Seventh fault in past is read
0101H	3H	Forth fault in past is read	0101H	7H	Eighth fault in past is read

\*1 Writing a value of 0000H to this parameter resets all faults history. All other parameters at this index are read only.

<Fault data>

Refer to *the inverter manual* for details of alarm definitions.

Error Number	Definition
00H	No fault present
10H	E.OC1
11H	E.OC2
12H	E.OC3
20H	E.OV1
21H	E.OV2
22H	E.OV3
30H	E.THT
31H	E.THM
40H	E.FIN
52H	E.ILF
60H	E.OLT

Error Number	Definition
70H	E.BE
80H	E.GF
81H	E.LF
90H	E.OHT
A1H	E.OP1
B0H	E.PE
B1H	E.PUE
B2H	E.RET
B3H	E.PE2
C0H	E.CPU
C5H	E.IOH
C7H	E.AIE

Error Number	Definition
C8H	E.USB
D8H	E.MB4
D9H	E.MB5
DAH	E.MB6
DBH	E.MB7
F1H	E. 1
F5H	E. 5
F6H	E. 6
F7H	E. 7
FDH	E. 13

## 8.8 Standard parameters

### 8.8.1 Normal parameter area (IND = 0200H (IND = 02H, PP = 00H))

You can use the PNU to make parameter settings from the network.

The table below lists PNU numbers corresponding to parameter numbers.

Standard parameter examples are introduced below. Refer to the examples and make parameter settings.

Refer to the inverter manual for details of the parameters.

#### Example of parameter list

IND	PNU	Parameter Number	Name	Minimum Setting Increments	Setting Range	
					Decimal	Hexadecimal
0200H	0H	0	Torque boost	0.1%	0 to 30	0 to 12C
	1H	1	Maximum frequency	0.01Hz	0 to 120	0 to 2EE0
	2H	2	Minimum frequency	0.01Hz	0 to 120	0 to 2EE0
	3H	3	Base Frequency	0.01Hz	0 to 400	0 to 9C40
	4H	4	Multi-speed setting (high speed)	0.01Hz	0 to 400	0 to 9C40
	5H	5	Multi-speed setting (middle speed)	0.01Hz	0 to 400	0 to 9C40
	6H	6	Multi-speed setting (low speed)	0.01Hz	0 to 400	0 to 9C40
	:	:	:	:	:	:

#### CAUTION

- Write to Pr. 77 and Pr. 79 is not allowed from the network with the FR-A7NP. (Read is allowed.)

### 8.8.2 Pr. 900 to calibration parameter (frequency) area (IND=0300H (IND=03H, PP=00H))

The following parameters can be set with IND=0300H.

IND	PNU	Parameter Number	Name	Minimum Setting Increments	Setting Range	
					Decimal	Hexadecimal
0300H	0H	900	FM terminal calibration *1	-	-	-
0300H	1H	901	AM terminal calibration *2	-	-	-
0300H	2H	902	Terminal 2 frequency setting bias frequency	0.01Hz	0 to 400	0 to 9C40
0300H	3H	903	Terminal 2 frequency setting gain frequency	0.01Hz	0 to 400	0 to 9C40
0300H	4H	904	Terminal 4 frequency setting bias frequency	0.01Hz	0 to 400	0 to 9C40
0300H	5H	905	Terminal 4 frequency setting gain frequency	0.01Hz	0 to 400	0 to 9C40
0300H	16H	922	Frequency setting voltage bias frequency (built-in potentiometer) *1	0.01Hz	0 to 400	0 to 9C40
0300H	17H	923	Frequency setting voltage gain frequency (built-in potentiometer) *1	0.01Hz	0 to 400	0 to 9C40

\*1 These parameters can be set for the Japanese version only.

\*2 This parameter can be set for the NA, EC and CH versions only.

**8.8.3 Pr. 900 to calibration parameter (%) area (IND=0400H (IND=04H, PP=00H))**

The following parameters can be set with IND=0400H.

IND	PNU	Parameter Number	Name	Minimum Setting Increments
0400H	2H	902	Terminal 2 frequency setting bias	0.1%
0400H	3H	903	Terminal 2 frequency setting gain	0.1%
0400H	4H	904	Terminal 4 frequency setting bias	0.1%
0400H	5H	905	Terminal 4 frequency setting gain	0.1%
0400H	16H	922	Frequency setting voltage bias (built-in potentiometer) *	0.1%
0400H	17H	923	Frequency setting voltage gain (built-in potentiometer) *	0.1%

\* These parameters can be set for the Japanese version only.

# 9 TROUBLESHOOTING

When a fault occurs where the inverter trips itself and the option unit, check the inverter's operation panel, the LED on the option unit, and the following checkpoints to identify the cause, then take appropriate countermeasures. If the fault does not correspond to any of the following faults or if you have any other problem, please contact your sales representative.

Operation Panel Display on the Inverter	LED on FR-A7NP	Possible Cause		Checkpoint / Troubleshooting
0.00	Off	The option unit is not operating.	The option unit is not mounted properly.	Check if the option unit is mounted properly.
			PROFIBUS communication is not established with the master. (Incorrect node address setting)	Set the same node address with the master on A7NP using the node address switches. (Turn OFF, then ON the power supply after changing the node address setting on A7NP.)
			PROFIBUS communication is not established with the master. (Incorrect GSD file has been registered.)	Register the correct GSD file with a configuration software, and set the network configuration to the master.
			PROFIBUS communication is not established with the master. (Incorrect wiring)	Check the wiring of the option unit. D+ PROFIBUS transmitting/receiving data+ (B line) D- PROFIBUS transmitting/receiving data- (A line)
		—	Reset the inverter. Perform all parameter clear to initialize all parameter settings, then turn ON the inverter power again.	
	The network is unstable.	The network cables are not connected correctly.	Check if the network cables are connected properly between the nodes.	
		The PROFIBUS communication is not established with the master. (Unstable bus line)	Connect a terminating resistor. If a terminating resistor has been already connected, check if it is connected properly.	
		The network setting is incorrect.	Check the network setting with the PROFIBUS-DP network configuration software.	
		The inverter is affected by the other nodes.	Check if any network error has occurred in the other nodes.	
	Lit in red	No master is present in the network, or the master is not properly operating.	Check the connection and the operation of the PROFIBUS-DP master.	





Operation Panel Display on the Inverter	LED on FR-A7NP	Possible Cause	Checkpoint / Troubleshooting
E.OP1	Lit in red	The PROFIBUS communication had been established (the green LED had been lit), but the master stopped transmitting data to the option unit during an inverter stop.	Check the connection and the wiring of the communication cable.
		Communication errors occurred consecutively after the PROFIBUS communication had been established (green LED had been ON).	Connect a terminating resistor. If a terminating resistor has been already connected, check if it is connected properly.
		The PROFIBUS communication had been established (the green LED had been lit), but the master stopped transmitting data to the option unit during an inverter stop.	Check the master ladder, etc., and remove the causes that disconnect the data transmission between the master and the option unit.

# MEMO



# INVERTER



IB(NA)-0600346ENG-B(1011) MEE

Printed in Japan

Specifications subject to change without notice.