



**MITSUBISHI  
ELECTRIC**

---

# QCPU(A mode) CPU Module

---

User's Manual  
(Hardware)  
**Q02CPU-A**  
**Q02HCPU-A**  
**Q06HCPU-A**

Thank you for purchasing the Mitsubishi programmable controller MELSEC-Q series.

Prior to use, please read this and relevant manuals thoroughly to fully understand the product.

**MELSEC-Q**

Mitsubishi Programmable  
Controller

MODEL	QCPU-A(A)-U-H/W-E
MODEL CODE	13JR04
IB(NA)-0800084-M(1405)MEE	



## ● SAFETY PRECAUTIONS ●

(Read these precautions before using this product.)

Before using this product, please read this manual and the relevant manuals carefully and pay full attention to safety to handle the product correctly.

In this manual, the safety precautions are classified into two levels:

"⚠ WARNING" and "⚠ CAUTION".



Indicates that incorrect handling may cause hazardous conditions, resulting in death or severe injury.



Indicates that incorrect handling may cause hazardous conditions, resulting in minor or moderate injury or property damage.

Under some circumstances, failure to observe the precautions given under "⚠ CAUTION" may lead to serious consequences.

Observe the precautions of both levels because they are important for personal and system safety.

Make sure that the end users read this manual and then keep the manual in a safe place for future reference.

## [DESIGN PRECAUTIONS]

### **WARNING**

- Configure safety circuits external to the programmable controller to ensure that the entire system operates safely even when a fault occurs in the external power supply or the programmable controller. Failure to do so may result in an accident due to an incorrect output or malfunction.
  - (1) Configure external safety circuits, such as an emergency stop circuit, protection circuit, and protective interlock circuit for forward/reverse operation or upper/lower limit positioning.
  - (2) When the programmable controller detects the following error conditions, it stops the operation and turn off all the outputs.
    - Overcurrent or overvoltage protection of the power supply module is activated.
    - The CPU module detects an error such as a watchdog timer error by the self-diagnostics function.All outputs may turn on when an error occurs in the part, such as I/O control part, where the CPU module cannot detect any error. To ensure safety operation in such a case, provide a safety mechanism or a fail-safe circuit external to the programmable controller. For a fail-safe circuit example, refer to Chapter 4 LOADING AND INSTALLATION in this manual.
  - (3) Outputs may remain on or off due to a failure of an output module relay or transistor. Configure an external circuit for monitoring output signals that could cause a serious accident.
- In an output module, when a load current exceeding the rated current or an overcurrent caused by a load short-circuit flows for a long time, it may cause smoke and fire. To prevent this, configure an external safety circuit, such as a fuse.
- Configure a circuit so that the programmable controller is turned on first and then the external power supply. If the external power supply is turned on first, an accident may occur due to an incorrect output or malfunction.
- For the operating status of each station after a communication failure, refer to relevant manuals for the network.

Incorrect output or malfunction due to a communication failure may result in an accident.

## [DESIGN PRECAUTIONS]

### **WARNING**

- When controlling a running programmable controller from a peripheral connected to the CPU module or from a personal computer connected to a special function module, configure an interlock circuit in the sequence program to ensure that the entire system will always operate safely. For program modification and operating status change, read relevant manuals carefully and ensure the safety before operation. Especially, in the case of a control from an external device to a remote programmable controller, immediate action cannot be taken for a problem on the programmable controller due to a communication failure. To prevent this, configure an interlock circuit in the sequence program, and determine corrective actions to be taken between the external device and CPU module in case of a communication failure.
- When setting up the system, do not allow any empty slot on the base unit. If any slot is left empty, be sure to use a blank cover (A1SG60) or a dummy module (A1SG62) for it. Otherwise, internal parts of the module may be fried in the short circuit test or when an overcurrent or overvoltage is accidentally applied to the external I/O section.

### **CAUTION**

- Do not install the control lines or communication cables together with the main circuit lines or power cables. Keep a distance of 100mm (3.9inches) or more between them. Failure to do so may result in malfunction due to noise.
- When a device such as a lamp, heater, or solenoid valve is controlled through an output module, a large current (approximately ten times greater than normal) may flow when the output is turned from off to on. Take measures such as replacing the module with one having a sufficient current rating.
- After the CPU module is powered on or is reset, the time taken to enter the RUN status varies depending on the system configuration, parameter settings, and/or program size. Design circuits so that the entire system will always operate safely, regardless of the time.

## [INSTALLATION PRECAUTIONS]

### CAUTION

- Use the programmable controller under the environment that meets the general specifications in this manual.  
Failure to do so may result in electric shock, fire, malfunction, or damage to or deterioration of the product.
- To mount the CPU module, while pressing the module mounting lever located in the lower part of the module, fully insert the module fixing projection(s) into the hole(s) in the base unit and press the module until it snaps into place.  
Incorrect mounting may cause malfunction, failure or a drop of the module.  
When using the programmable controller in an environment of frequent vibrations, fix the module with the screw.  
Tighten the screw within the specified torque range.  
Undertightening can cause drop of the screw, short circuit or malfunction.  
Overtightening can damage the screw and/or module, resulting in drop, short circuit, or malfunction.
- Insert securely the module fixing projection at the bottom of the AnS series module into the fixing hole in the base unit and then tighten the module fixing screw within the specified torque.  
When no screw is tightened, even if the module is installed correctly, it may cause malfunctions, a failure or a drop of the module.  
Tightening the screw excessively may damage the screw and/or the module, resulting in a drop of the module, a short circuit or malfunctions.
- When using an extension cable, connect it to the extension cable connector of the base unit securely.  
Check the connection for looseness.  
Poor contact may cause incorrect input or output.
- When using a memory card, fully insert it into the memory card slot.  
Check that it is inserted completely.  
Poor contact may cause malfunction.
- Shut off the external power supply for the system in all phases before mounting or removing the module.  
Failure to do so may result in damage to the product.
- Do not directly touch any conductive part of the module.  
Doing so can cause malfunction or a failure of the module.

## [WIRING PRECAUTIONS]

### **WARNING**

- Shut off the external power supply for the system in all phases before wiring. Failure to do so may result in electric shock or damage to the product.
- After wiring, attach the included terminal cover to the module before turning it on for operation. Failure to do so may result in electric shock.

### **CAUTION**

- Ground the FG and LG terminals to the protective ground conductor dedicated to the programmable controller. Failure to do so may result in electric shock or malfunction.
- Use applicable solderless terminals and tighten them with the specified torque range. If any solderless terminal is used, it may be disconnected when the terminal screw comes loose, resulting in failure.
- Check the rated voltage and terminal layout before wiring to the module, and connect the cables correctly. Connecting a power supply with a different voltage rating or incorrect wiring may cause a fire or failure.
- Do not connect multiple power supply modules to one module in parallel. The power supply modules may be heated, resulting in a fire or failure.
- Connectors for external connection must be crimped or pressed with the tool specified by the manufacturer, or must be correctly soldered. Incomplete connections could result in short circuit, fire or malfunction.
- Tighten the terminal screws within the specified torque range. Undertightening can cause short circuit, fire, or malfunction. Overtightening can damage the screw and/or module, resulting in drop, short circuit, or malfunction.
- Prevent foreign matter such as dust or wire chips from entering the module. Such foreign matter can cause a fire, failure or malfunction.
- A protective film is attached to the top of the module to prevent foreign matter, such as wire chips, from entering during wiring. Do not remove the film during wiring. Remove it for heat dissipation before system operation.

## [WIRING PRECAUTIONS]

### CAUTION

- Mitsubishi programmable controllers must be installed in control panels. Connect the main power supply to the power supply module in the control panel through a relay terminal block. Wiring and replacement of a power supply module must be performed by maintenance personnel who is familiar with protection against electric shock. (For the wiring methods, refer to QCPU (A mode) User's Manual.)

## [STARTUP AND MAINTENANCE PRECAUTIONS]

### WARNING

- Do not touch any terminal while power is on. Doing so will cause electric shock.
- Correctly connect the battery connector. Do not charge, disassemble, heat, short-circuit, solder, or throw the battery into the fire. Doing so will cause the battery to produce heat, explode, or ignite, resulting in injury and fire.
- Shut off the external power supply for the system in all phases before cleaning the module or retightening the terminal screws or module fixing screws. Failure to do so may result in electric shock. Undertightening the terminal screws can cause short circuit or malfunction. Overtightening can damage the screw and/or module, resulting in drop, short circuit, or malfunction.

### CAUTION

- Before performing online operations (especially, program modification, forced output and operating status change) for the running CPU module from the peripheral connected, read relevant manuals carefully and ensure the safety. Improper operation may damage machines or cause accidents.
- Do not disassemble or modify the modules. Doing so may cause failure, malfunction, injury, or a fire.
- Use any radio communication device such as a cellular phone or PHS (Personal Handy-phone System) more than 25cm (9.84inches) away in all directions from the programmable controller. Failure to do so may cause malfunction.



## [STARTUP AND MAINTENANCE PRECAUTIONS]

### CAUTION

- Shut off the external power supply for the system in all phases before mounting or removing the module. Failure to do so may cause the module to fail or malfunction.
- After the first use of the product, do not mount/remove the module to/from the base unit, and the terminal block to/from the module more than 50 times (IEC 61131-2 compliant) respectively.  
Exceeding the limit of 50 times may cause malfunction.
- Do not drop or apply any shock to the battery to be installed in the module. Doing so may damage the battery, causing the battery fluid to leak inside the battery. If the battery is dropped or any shock is applied to it, dispose of it without using.
- Before handling the module, touch a grounded metal object to discharge the static electricity from the human body.  
Failure to do so may cause the module to fail or malfunction.

## [DISPOSAL PRECAUTIONS]

### CAUTION

- When disposing of the product, treat it as an industrial waste.  
When disposing of batteries, separate them from other wastes according to the local regulations.  
(For details of the Battery Directive in EU member states, refer to QCPU-A (A mode) User's Manual.)

## [TRANSPORTATION PRECAUTIONS]

### CAUTION

- When transporting lithium batteries, follow the transportation regulations. (For details of the regulated models, refer to Chapter 7.)

## ● PRÉCAUTIONS DE SÉCURITÉ ●

(Lire ces précautions avant toute utilisation du produit.)

Avant d'utiliser ce produit, lire attentivement ce manuel ainsi que les manuels auxquels il renvoie, et toujours considérer la sécurité comme de la plus haute importance en manipulant le produit correctement.

Dans ce manuel, les précautions de sécurité sont classées en deux niveaux, à savoir : "⚠️ AVERTISSEMENT" et "⚠️ ATTENTION".

### **⚠️ AVERTISSEMENT**

Attire l'attention sur le fait qu'une négligence peut créer une situation de danger avec risque de mort ou de blessures graves.

### **⚠️ ATTENTION**

Attire l'attention sur le fait qu'une négligence peut créer une situation de danger avec risque de blessures légères ou de gravité moyennes ou risque de dégâts matériels.

Dans certaines circonstances, le non-respect d'une précaution de sécurité introduite sous le titre "⚠️ ATTENTION" peut avoir des conséquences graves.

Les précautions de ces deux niveaux doivent être observées dans leur intégralité car elles ont trait à la sécurité des personnes et aussi du système.

Veiller à ce que les utilisateurs finaux lisent ce manuel qui doit être conservé soigneusement à portée de main pour s'y référer autant que de besoin.

 **AVERTISSEMENT**

- *Configurer des circuits de sécurité extérieurs à l'automate programmable pour garantir la sécurité du système dans son ensemble à la survenance d'une anomalie dans l'alimentation externe comme dans l'automate programmable. Faute de quoi, une instruction de sortie incorrecte ou un dysfonctionnement pourrait être à l'origine d'un accident.*
  - (1) *Configurer des circuits de sécurité externes, comme un circuit d'arrêt d'urgence, un circuit de protection et les circuits de verrouillage de sécurité pour l'opération d'inversion de marche avant/arrière et de positionnement en limite haute/basse.*
  - (2) *Quand l'automate programmable détecte l'un des états d'erreur ci-après, il interrompt la marche et il désactive les sorties.*
    - *La protection contre surintensité ou surtension du module d'alimentation a déclenché.*
    - *Le module CPU détecte une erreur, telle qu'une erreur d'horloge de surveillance détectée par la fonction d'autodiagnostic.*

*Il se peut toutefois que toutes les sorties restent actives si l'erreur se produit dans un organe où le module CPU ne peut pas détecter les erreurs, comme par exemple un organe de commande d'entrée/sortie. Pour garantir la sécurité en exploitation dans une telle éventualité, il faut donc prévoir un mécanisme de sécurité ou un circuit de mise en sécurité à l'extérieur de l'automate programmable. On trouvera un exemple de circuit de mise en sécurité dans le présent manuel, chapitre 4 "CHARGEMENT ET INSTALLATION".*
  - (3) *Une panne de relais ou de transistor dans un module de sortie pourrait activer ou interrompre certaines sortie. Configurer un circuit de surveillance externe pour le suivi des signaux de sortie susceptibles de provoquer un accident grave.*
- *Dans un module de sortie, un courant de charge plus fort que le courant nominal ou une surintensité produite par un court-circuit peuvent, s'ils se prolongent, être à l'origine d'un dégagement de fumée ou d'un départ de feu. Pour éviter cela, il faut configurer un circuit de sécurité, avec un fusible par exemple.*
- *Configurer le circuit de façon à allumer d'abord l'automate programmable avant l'alimentation externe. Si on commence par brancher l'alimentation externe, ceci peut être une cause d'accident en cas de sortie incorrecte ou autre dysfonctionnement.*

 **AVERTISSEMENT**

- *Quant à l'état opérationnel de chacune des stations en cas de problème de communication, voir les manuels correspondants pour le réseau. Une sortie erronée ou un dysfonctionnement suite à une erreur de communication peuvent être à l'origine d'un accident.*
- *Si l'automate programmable doit être commandé à partir d'un périphérique raccordé au module CPU ou à partir d'un ordinateur personnel raccordé à un module fonctionnel spécial, il faut dans le programme séquentiel constituer un circuit de verrouillage permettant de garantir en tous temps la sécurité de l'ensemble du système.*

*Avant de procéder à des modifications dans le programme ou à des changements d'état fonctionnel, lire attentivement les manuels correspondants et s'assurer de pouvoir opérer en toute sécurité.*

*En particulier, lorsqu'un automate programmable distant est commandé à partir d'un dispositif externe, il faut tenir compte du fait qu'aucune action immédiate ne sera possible s'il y a un problème de communication avec l'automate programmable.*

*Pour éviter cela, constituer un circuit de verrouillage dans le programme séquentiel, et prévoir les mesures correctives à prendre entre le dispositif externe et le module CPU en cas de problème de communication.*
- *Au montage du système, il ne doit rester aucune fente à carte vide sur l'unité de base.*

*S'il reste une fente à carte vide, il est indispensable de la boucher avec un couvercle d'obturation (A1SG60) ou d'y insérer un module factice (A1SG62). Sinon, des organes internes du module pourraient être projetés lors d'un essai de court-circuit, ou si une surintensité ou une surtension est accidentellement appliquée à une section entrée/sortie.*

## **[Précautions lors de la conception]**

### **ATTENTION**

- *Ne pas entremêler les lignes de commandes ou câbles de communication avec les lignes des circuits principaux ou les câbles d'alimentation. Maintenir entre eux une distance d'au moins 100mm (3,9pouces). Faute de quoi, il y a risque de dysfonctionnement par un bruit.*
- *Lorsque le module de sortie commande un dispositif comme une lampe, un réchauffeur ou une électrovanne, un fort courant (jusqu'à 10 fois l'intensité normale) traverse la sortie quand celle-ci passe de OFF à ON. Prendre les mesures indispensables, comme le remplacement du module par un autre ayant une capacité de courant suffisante.*
- *À la mise sous tension ou à la réinitialisation du module CPU, le temps nécessaire à l'entrée en état RUN dépend de la configuration du système, du paramétrage et/ou de la taille du programme. Concevoir les circuits de manière que tout le système fonctionne en sécurité, indépendamment de ce temps.*

## **[Précautions d'installation]**

### **ATTENTION**

- *Utiliser l'automate programmable dans un environnement en conformité avec les spécifications générales que présente ce manuel. Faute de quoi, il a risque d'électrocution, de départ de feu, de dysfonctionnement, d'endommagement ou de détérioration du produit.*
- *Pour fixer le module CPU à sa place, tout en appuyant sur le levier de fixation qui se trouve à la partie inférieure du module, engager le(s) ergot(s) de fixation du module à fond dans le(s) trou(s) du socle et appuyer sur le module jusqu'à encliquètement. Une fixation incorrecte peut être à l'origine de pannes, de dysfonctionnements ou d'une chute du module. Si l'automate programmable est installé dans un environnement exposé aux vibrations, le module doit être immobilisé par une vis de blocage. Serrer la vis dans les limites du couples de serrage prescrit. Si les vis sont insuffisamment serrées, le module risque de tomber et il peut y avoir des court-circuits ou des dysfonctionnements. Un serrage excessif peut endommager les vis et/ou le module, avec aussi un risque de chute, de court-circuits et de dysfonctionnements.*

## **[Précautions d'installation]**

### **ATTENTION**

- *Introduire fermement l'ergot de fixation à la base du module de série AnS dans le trou de fixation du socle, puis serrer la vis de fixation du module au couple prescrit.  
Si on ne serre pas la vis, même si le module a bien pris sa place, il peut y avoir dysfonctionnement, panne ou même chute du module.  
Un serrage excessif pourrait endommager la vis et/ou le module et il y aurait aussi risque de chute du module, de court-circuit ou de dysfonctionnements.*
- *Si on utilise un câble de rallonge, le raccorder fermement sur le connecteur pour câble de rallonge sur l'unité de base.  
Vérifier que les connexions ne sont pas desserrées.  
Un mauvais contact peut être à l'origine d'une entrée ou sortie erronée.*
- *Quand on utilise une carte-mémoire, l'insérer bien à fond dans la fente pour carte-mémoire.  
Vérifier que la carte a été poussée bien à fond dans le logement.  
Tout mauvais contact peut être source de dysfonctionnements.*
- *Couper l'alimentation externe du système sur toutes les phases avant la mise en place ou le retrait du module.  
Faute de quoi, le produit risquerait d'être endommagé.*
- *Éviter tout contact direct avec les parties conductrices du module.  
Cela pourrait être à l'origine de dysfonctionnements ou d'une panne du module.*

## **[Précautions de câblage]**

### **AVERTISSEMENT**

- *Couper l'alimentation externe du système sur toutes les phases avant de commencer à câbler.  
Faute de quoi, il y a risque d'électrocution et d'endommagement du produit.*
- *Après câblage, mettre le couvre-bornes fourni en place avant de procéder à la mise sous tension pour mettre en marche.  
Faute de quoi, il y a risque d'électrocution.*

## **[Précautions de câblage]**

### **ATTENTION**

- *Mettre à la masse les bornes FG et LG sur le conducteur réservé à la protection à la terre de l'automate programmable.  
Faute de quoi, il y a risque d'électrocution et de dysfonctionnement.*
- *Utiliser des bornes sans soudure du type prescrit en les serrant au couple prescrit. Une borne sans soudure dont la vis se desserre peut être une source de mauvais contact avec risque de panne.*
- *Vérifier la tension nominale et l'affectation des bornes avant le câblage du module et raccorder les câbles correctement.  
Le raccordement d'une alimentation d'une tension autre que la tension nominale ou une erreur de câblage peut être à l'origine d'un départ de feu ou d'une panne.*
- *Ne pas raccorder plusieurs modules d'alimentation en parallèle sur un même module. La surchauffe des modules d'alimentation pourrait entraîner un départ de feu ou être à l'origine d'une panne.*
- *Les connecteurs pour connexions externes doivent être sertis ou comprimés avec l'outil prescrit par le fabricant ou, à défaut, doivent être soudés correctement.  
Une connexion imparfaite peut être à l'origine d'un court-circuit ou d'un départ de feu, ou entraîner des dysfonctionnements.*
- *Serrer les vis de borne dans les limites du couple de serrage prescrit.  
Si les vis sont insuffisamment serrées, il y a risque de court-circuits, départ de feu ou dysfonctionnement.  
Un serrage excessif peut endommager les vis et/ou le module, avec aussi un risque de chute, de court-circuits et de dysfonctionnements.*
- *Veiller à ne pas laisser la poussière, les copeaux métalliques ou d'autres corps étrangers pénétrer dans le module. Tout corps étranger peut être à l'origine d'un départ de feu, d'une panne ou d'un dysfonctionnement.*
- *Le haut du module est recouvert d'un film protecteur pour éviter toute pénétration de corps étrangers comme des copeaux métalliques pendant le câblage.  
Ne pas retirer le film protecteur avant de terminer le câblage.  
Il doit cependant être retiré avant la mise en service du système pour une meilleure dispersion de la chaleur.*

## **[Précautions de câblage]**

### **ATTENTION**

- *Les automates programmable Mitsubishi doivent être installés en tableau ou armoire de commande.  
Raccorder l'alimentation principale au module d'alimentation dans le tableau de commande sur une plaque à bornes avec relais.  
Le câblage et le remplacement d'un module d'alimentation doivent être effectués par un personnel d'entretien averti des risques d'électrocution. (À propos des méthodes de câblage, se reporter au Manuel de l'utilisateur QCPU (mode A).)*

## **[Précautions de mise en service et de maintenance]**

### **AVERTISSEMENT**

- *Ne toucher à aucun des bornes quand le système est sous tension. Il y aurait risque d'électrocution.*
- *Raccorder correctement le connecteur des piles. Les piles ne doivent pas être rechargées, démontées, court-circuitées ou soudées. Elles ne doivent pas non plus être jetées au feu.  
Ceci risquerait de faire surchauffer ou éclater les piles qui, si elles s'enflammaient, pourraient être à l'origine de blessures ou d'un départ de feu.*
- *Couper l'alimentation du système sur toutes les phases avant le nettoyage du module ou avant le resserrage des vis de bornes ou des vis de fixation du module. Faute de quoi, il y a risque d'électrocution.  
Un serrage insuffisant des vis de bornes peut être à l'origine d'un court-circuit ou de dysfonctionnement.  
Un serrage excessif peut endommager les vis et/ou le module, avec aussi un risque de chute, de court-circuits et de dysfonctionnements.*



 **ATTENTION**

- *Avant d'effectuer une opération en ligne (en particulier une modification de programme, une sortie forcée ou un changement d'état fonctionnel) sur un module CPU en marche à partir d'un périphérique connecté, consulter les manuels correspondants pour être sûr de pouvoir opérer en toute sécurité. Une fausse manœuvre pourrait être à l'origine d'un accident ou de dégâts matériels.*
- *Ne pas démonter ni modifier les modules.  
Cela pourrait entraîner des pannes ou dysfonctionnements et être à l'origine de blessures ou de départs de feu.*
- *Tout type d'appareil de communication radio, y compris les téléphones portables et les appareils PHS (Personal handy-phone system), doit être tenus éloignés de plus de 25cm (9,84pouces) de l'automate programmable, dans tous les sens.  
Le non-respect de cette précaution expose à des dysfonctionnements.*
- *Couper l'alimentation externe du système sur toutes les phases avant la mise en place ou le retrait du module. Le non-respect de cette précaution peut être à l'origine de pannes ou de dysfonctionnements du module.*
- *Après la mise en service du produit, le nombre maximum admissible d'opérations d'insertion/retrait du module sur le socle ou de la plaque à bornes sur le module est de 50 (matériel selon norme IEC 61131-2).  
Dépasser ce nombre maximum de 50 opérations d'insertion/retrait peut être à l'origine de dysfonctionnements.*
- *Ne pas faire tomber ou soumettre à de forts chocs les piles à installer dans les modules.  
Cela pourrait endommager les piles, avec risque de fuite du liquide à l'intérieur des piles. Toute pile qu'on a laissé tomber ou qui a subi un choc violent doit être jetée avant usage.*
- *Avant de manipuler un module, se débarrasser de la charge électrostatique qu'accumule le corps humain en touchant un objet métallique raccordé à la terre.  
Le non-respect de cette précaution peut être à l'origine de pannes ou de dysfonctionnements du module.*

### **[Précautions de mise au rebut]**

#### **ATTENTION**

- *Pour le mettre au rebut, ce produit doit être traité comme un déchet industriel. Les piles ou batteries doivent être mises au rebut séparément des autres déchets et conformément à la réglementation locale. (Pour le détail des directives sur les piles et batteries dans les pays de l'Union Européenne, voir le Manuel de l'utilisateur QCPU-A (mode A).)*

### **[Précautions de transport]**



#### **ATTENTION**

- *Pour le transport des piles au lithium, respecter la réglementation afférente à ce transport. (Pour le détail des modèles soumis à une réglementation, se reporter au chapitre 7.)*

## ●安全注意事项●

(使用之前请务必阅读)

在使用本产品之前，应仔细阅读本手册以及本手册中所介绍的相关手册，同时在充分注意安全的前提下正确操作。

在“安全注意事项”中，安全注意事项被分为“警告”和“注意”两个等级。



**警告**

表示错误操作可能造成危险后果，导致死亡或重伤事故。



**注意**

表示错误操作可能造成危险后果，导致中度伤害、轻伤或财产损失。

此外，根据情况不同，即使标注为“注意”的事项也有可能引发严重后果。这两个等级的注意事项记载的均为重要内容，请务必遵守。

请妥善保管本手册以备需要时取阅，并将本手册交给最终用户。

## 【设计注意事项】

### 警告

- 应在可编程控制器外部设置一个安全电路，以保证整个系统在外部电源异常或可编程控制器本体故障时也能安全运行。  
否则可能由于误输出、误动作而导致事故发生。
- (1) 应在可编程控制器外部配置紧急停止电路、保护电路、正转 / 反转等相反动作的互锁电路、定位的上限 / 下限等防止设备破损的互锁电路等。
- (2) 可编程控制器在检测到下列异常状态时，会停止运算并 OFF 所有输出。
  - 电源模块的过电流保护装置或过电压保护装置工作时。
  - 可编程控制器 CPU 通过看门狗定时器错误等自诊断功能检测到异常时。此外，出现可编程控制器 CPU 所无法检测的输入输出控制部分等的异常时，所有输出可能会为 ON。此时，应在可编程控制器外部设置一个失效安全电路或装置，以保证设备安全运行。  
失效安全电路的示例请参照本用户手册的实际安装与设置。
- (3) 输出模块的继电器以及晶体管等的故障可能会导致输出保持 ON 状态或 OFF 状态。对于可能导致重大事故发生的输出信号，应在外部设置监视电路。
- 输出模块因为超过额定的负载电流或负载短路等导致长时间过电流时，可能会导致冒烟、火灾，因此请在外部设置保险丝等安全电路。
- 应配置成在可编程控制器本体电源接通后再接通外部供应电源的电路。  
如果外部供应电源先接通，可能由于误输出、误动作而导致事故发生。

## 【设计注意事项】

### ⚠ 警告

- 关于数据链接出现通信异常时各站的动作状态，请参照各数据链接的手册。否则可能由于误输出、误动作而导致事故发生。
- 在 CPU 模块上连接周边机器，或在特殊功能模块上连接计算机等以对运行中的可编程控制器进行控制（数据更改）时，应在顺控程序上配置互锁电路，以保证整个系统始终能安全运行。  
此外，对运行中的可编程控制器进行其他控制（程序更改、运行状态更改（状态控制））时，应仔细阅读相关手册，在充分确认安全的基础上进行操作。特别是在通过外部机器对远程的可编程控制器进行上述控制时，可能会因为数据通信异常而导致无法立即对可编程控制器侧的故障做出反应。  
在顺控程序上配置互锁电路的同时，应在外部机器与可编程控制器 CPU 之间确定发生数据通信异常时的系统的处理方法。
- 配置系统时，请勿在基板上设置空插槽。  
出现空插槽时，请务必使用空槽盖板（A1SG60）、虚拟模块（A1SG62）。  
进行短路试验时，或误对外部输入输出部施加过电流或过电压时，模块的内部部件可能会四处飞散。

### ⚠ 注意

- 请勿将控制线及通信电缆与主电路及动力线等捆扎在一起或相互靠得太近。应相距大约 100mm 以上距离。  
因为噪声有可能导致误动作。
- 通过输出模块控制指示灯负载、加热器、电磁阀等时，输出的 OFF → ON 时可能会有大电流（通常的 10 倍左右）流过，因此请采取改用额定电流有充足余地的模块等措施。
- CPU 模块的电源关闭→接通或复位时，CPU 模块变为 RUN 状态为止的时间会因系统配置、参数设置、程序容量等而变动。  
应通过设计使得在变为 RUN 状态为止的时间发生变动时也能保证整个系统安全运行。

## 【安装注意事项】

### ⚠ 注意

- 应在本手册记载的一般规格环境下使用可编程控制器。  
如果在一般规格范围以外的环境中使用可编程控制器，可能导致触电、火灾、误动作、产品损坏或性能劣化。
- CPU 模块应在按住模块下部的模块安装手柄的同时，将模块固定用凸起部切实插入到基板的固定孔中，以模块固定孔为支点进行安装。  
如果模块未正确安装，有可能造成误动作、故障或掉落。  
在振动较多的环境下使用时，应使用螺栓固定模块。  
应在规定的扭矩范围内拧紧螺栓。  
如果螺栓拧得过松，有可能导致掉落、短路或误动作。  
如果螺栓拧得过紧，有可能造成螺栓及模块损坏从而导致掉落、短路或误动作。
- AnS 系列的模块应在将模块下部的模块固定用凸起部切实插入基板的固定孔后，以规定的扭矩拧紧模块固定螺栓。  
如果模块未正确安装并以螺栓固定，有可能造成误动作、故障或掉落。  
如果螺栓拧得过紧，有可能造成螺栓及模块损坏从而导致掉落、短路或误动作。
- 扩展电缆应切实安装到基本模块的扩展电缆用接口上。安装后应检查有无浮起。  
因为接触不良有可能导致误输入、误输出。
- 存储卡应按入存储卡安装用接口中并切实安装。  
安装后应检查有无浮起。  
因为接触不良有可能导致误动作。
- 在拆装模块时，必须将系统使用的外部供应电源全部断开后再进行操作。  
如果未全部断开，有可能导致产品损坏。
- 请勿直接触碰模块的导电部分。  
否则可能导致模块误动作、故障。

## 【配线注意事项】

### ⚠ 警告

- 在配线作业等时，必须将系统使用的外部供应电源全部断开后再进行操作。如果未全部断开，有可能导致触电或产品损坏。
- 配线作业结束后进行通电、运行时，必须安装产品附带的端子盖。如果未安装端子盖，有可能导致触电。

### ⚠ 注意

- 必须将 FG 端子及 LG 端子与可编程控制器的专用接地线连接。否则有可能导致触电、误动作。
- 应使用合适的压装端子，并按规定扭矩拧紧。如果使用 Y 型压装端子，端子螺栓松动时可能导致脱落或故障。
- 进行模块配线作业时，应在确认产品的额定电压及端子排列的基础上正确进行操作。如果连接了与额定值不符的电源或配线错误，可能导致火灾或故障。
- 请勿将多个电源模块的输出并联。否则电源模块会过热，可能导致火灾或故障。
- 外部连接用接口应使用制造商指定的工具进行压装、压接或正确焊接。如果连接不牢固，可能导致短路、火灾或故障。
- 应在规定的扭矩范围内拧紧端子螺栓。如果端子螺栓拧得过松，有可能导致短路、火灾或误动作。如果端子螺栓拧得过紧，有可能造成螺栓及模块破损从而导致掉落、短路或误动作。
- 应注意防止切屑及配线头等异物掉入模块内。否则有可能导致火灾、故障或误动作。
- 为了防止配线时配线头等异物落入模块内，在模块顶部贴有防止异物落入用的标签。在配线作业期间请勿揭下该标签。在系统运行前，为了散热，必须将该标签揭下。

## 【配线注意事项】

### ⚠ 注意

- 本公司的可编程控制器应设置在控制盘内使用。与设置在控制盘内的可编程控制器电源模块之间的主电源配线应经由中继端子排进行。  
此外，电源模块的更换和配线作业应由接受过充分的触电防护教育的维护作业人员进行。  
配线方法请参照 QCPU-A (A 模式) 用户手册 (详细篇)。

## 【启动 / 维护注意事项】

### ⚠ 警告

- 在通电状态下请勿触摸端子。  
否则可能导致触电。
- 应正确连接电池接口。请勿对电池进行充电、拆解、加热、投入火中、短接、焊接等。如果错误使用电池，有可能因为电池发热、破裂或起火等而导致人身伤害、火灾。
- 在清洁模块或重新紧固端子螺栓、模块安装螺栓时，必须将系统使用的外部供应电源全部断开后再进行操作。  
如果未全部断开，有可能导致触电。  
如果端子螺栓拧得过松，有可能导致短路或误动作。  
如果螺栓拧得过紧，有可能造成螺栓及模块损坏从而导致掉落、短路或误动作。

### ⚠ 注意

- 把周边机器连接到运行中的 CPU 模块上进行在线操作 (特别是程序更改、强制输出、运行状态的更改) 前，应仔细阅读手册，在充分确认安全的基础上进行操作。  
否则操作错误有可能导致设备破损或事故。
- 请勿拆开或改造各模块。  
否则可能导致故障、误动作、人身伤害或火灾。
- 便携电话或 PHS 等无线通信设备应在距离可编程控制器本体 (各个方向) 25cm 以上的地方使用。  
否则可能导致误动作。



### 【启动 / 维护注意事项】

#### ⚠ 注意

- 在拆装模块时，必须将系统使用的外部供应电源全部断开后再进行操作。  
如果未全部断开，有可能导致模块故障或误动作。
- 产品投入使用后，模块和基板以及端子排的拆装次数不应超过 50 次。  
(根据 IEC61131-2 规范)  
如果超过了 50 次，有可能导致误动作。
- 请勿使模块中安装的电池掉落或受到撞击。  
掉落或受到撞击会导致电池破损，造成电池内部发生漏液。  
掉落或受到撞击的电池不可使用，应予以报废。
- 在触碰模块之前，必须先触碰已接地的金属等，释放掉人体等所携带的静电。  
如果不释放掉静电，有可能导致模块故障或误动作。

### 【报废处理注意事项】

#### ⚠ 注意

- 本产品报废时，应当作为工业废物处理。  
电池报废时应根据各地区所制定的法律法规分别进行。  
(关于欧盟成员国的电池管制的详细内容，请参照 QCPU-A (A 模式) 用户手册 (详细篇。))

### 【运输注意事项】

#### ⚠ 注意

- 在运输含锂电池时，应根据运输管制进行处理。(管制对象机种的详细内容请参照第7章。)

## ● CONDITIONS OF USE FOR THE PRODUCT ●

(1) Mitsubishi programmable controller ("the PRODUCT") shall be used in conditions;

- i) where any problem, fault or failure occurring in the PRODUCT, if any, shall not lead to any major or serious accident; and
- ii) where the backup and fail-safe function are systematically or automatically provided outside of the PRODUCT for the case of any problem, fault or failure occurring in the PRODUCT.

(2) The PRODUCT has been designed and manufactured for the purpose of being used in general industries.

MITSUBISHI SHALL HAVE NO RESPONSIBILITY OR LIABILITY (INCLUDING, BUT NOT LIMITED TO ANY AND ALL RESPONSIBILITY OR LIABILITY BASED ON CONTRACT, WARRANTY, TORT, PRODUCT LIABILITY) FOR ANY INJURY OR DEATH TO PERSONS OR LOSS OR DAMAGE TO PROPERTY CAUSED BY the PRODUCT THAT ARE OPERATED OR USED IN APPLICATION NOT INTENDED OR EXCLUDED BY INSTRUCTIONS, PRECAUTIONS, OR WARNING CONTAINED IN MITSUBISHI'S USER, INSTRUCTION AND/OR SAFETY MANUALS, TECHNICAL BULLETINS AND GUIDELINES FOR the PRODUCT.

("Prohibited Application")

Prohibited Applications include, but not limited to, the use of the PRODUCT in;

- Nuclear Power Plants and any other power plants operated by Power companies, and/or any other cases in which the public could be affected if any problem or fault occurs in the PRODUCT.
- Railway companies or Public service purposes, and/or any other cases in which establishment of a special quality assurance system is required by the Purchaser or End User.
- Aircraft or Aerospace, Medical applications, Train equipment, transport equipment such as Elevator and Escalator, Incineration and Fuel devices, Vehicles, Manned transportation, Equipment for Recreation and Amusement, and Safety devices, handling of Nuclear or Hazardous Materials or Chemicals, Mining and Drilling, and/or other applications where there is a significant risk of injury to the public or property.

Notwithstanding the above, restrictions Mitsubishi may in its sole discretion, authorize use of the PRODUCT in one or more of the Prohibited Applications, provided that the usage of the PRODUCT is limited only for the specific applications agreed to by Mitsubishi and provided further that no special quality assurance or fail-safe, redundant or other safety features which exceed the general specifications of the PRODUCTS are required. For details, please contact the Mitsubishi representative in your region.

## REVISIONS

\* The manual number is given on the bottom right of the front cover.

Print Date	*Manual Number	Revision
Dec.,1999	IB (NA)-0800084-A	First edition
Mar.,2000	IB (NA)-0800084-B	<u>Addition of model</u> QA1S33B
Dec.,2003	IB (NA)-0800084-C	<u>Addition of model</u> A1SY42P <u>Addition</u> Chapter 7 <u>Partial correction</u> SAFETY PRECAUTIONS, Section 5.2.1, 5.2.2
Dec.,2004	IB (NA)-0800084-D	<u>Partial correction</u> SAFETY PRECAUTIONS, CONTENTS, Section 2.1, 2.2, Chapter 3, Section 3.1.3, 3.1.4, 3.1.5, 3.2, 3.2.1, 3.2.2, 3.2.4, 4.1, 4.1.1, 4.1.4, 4.2, 4.3, 4.3.1, 4.3.2, 4.3.3, Chapter 5, Chapter 6, Section 6.2, Chapter 7
Jul.,2005	IB (NA)-0800084-E	<u>Addition</u> USER PRECAUTIONS <u>Partial correction</u> SAFETY PRECAUTIONS, Section 2.1, 2.2, 3.1.1, 3.1.3, 3.1.5, 3.2.2, 4.1, 4.2, 4.3.2, 4.5.2, 4.5.3, Chapter 5, Section 6.2
Oct.,2006	IB (NA)-0800084-F	<u>Partial correction</u> SAFETY PRECAUTIONS, Section 2.1, 2.2, 3.1.3, 3.2.4, 3.2.6, 4.1.2, 4.3.1, 4.3.2, 4.3.3, 5.2.1, 5.2.2, 6.2
May,2007	IB (NA)-0800084-G	<u>Partial correction</u> Section 3.1.1, 3.1.3, 3.2.7, 4.3.2, 4.3.3, 5.1.2, 5.2.1 <u>Addition</u> Section 3.1.7
Sep.,2008	IB (NA)-0800084-H	<u>Partial correction</u> SAFETY PRECAUTIONS, CONTENTS, USER PRECAUTIONS, Section 2.1, 2.2, 3.1, 3.1.1, 3.1.2, 3.1.3, 3.2, 3.2.3, 3.2.4, 3.2.5, 3.2.6, 3.2.7, 4.1, 4.1.1, 4.1.4, 4.2, 4.3.1, 4.3.2, 5.1.1, 5.2.1, Chapter 6
Sep.,2009	IB (NA)-0800084-I	<u>Partial correction</u> SAFETY PRECAUTIONS, CONTENTS, Chapter 3, Section 4.5.1, 7.1

\* The manual number is given on the bottom right of the front cover.

Print Date	*Manual Number	Revision
Jan., 2011	IB (NA)-0800084-J	<u>Partial correction</u> SAFETY PRECAUTIONS, Section 2.1, Chapter 3, Section 3.1, 3.1.3, 3.1.4, 3.1.5, 3.1.7, 4.2, 4.3.2, 4.4, 5.1.2, 5.2.2, 5.3.2, 6.2 <u>Addition</u> CONDITIONS OF USE FOR THE PRODUCT, Section 3.1.8
Aug., 2011	IB (NA)-0800084-K	<u>Partial correction</u> SAFETY PRECAUTIONS, Section 2.1, 2.2, 2.3, 3.1.1, 4.1, 4.2, 4.3.2, 5.1.2, 5.2.2, 5.3.2 <u>Addition</u> SAFETY PRECAUTIONS (Chinese)
Oct., 2011	IB (NA)-0800084-L	<u>Partial correction</u> Section 1.1, 2.3, 4.1.1, 4.1.2
May, 2014	IB (NA)-0800084-M	<u>Partial correction</u> SAFETY PRECAUTIONS, Section 3.1.3, 4.1.1

Japanese Manual Version IB(NA)-0800028-M

This manual confers no industrial property rights or any rights of any other kind, nor does it confer any patent licenses. Mitsubishi Electric Corporation cannot be held responsible for any problems involving industrial property rights which may occur as a result of using the contents noted in this manual.

---

---

# CONTENTS

---

---

1. OVERVIEW .....	1
1.1 Supplied Parts .....	1
2. GENERAL SPECIFICATIONS.....	3
2.1 General Specifications .....	3
2.2 Performance Specifications of CPU Modules .....	5
2.3 Specifications of Base Units.....	7
3. EMC DIRECTIVES AND LOW VOLTAGE DIRECTIVES.....	8
3.1 Requirements for Compliance with EMC Directive .....	8
3.1.1 Standards applicable to the EMC Directive.....	9
3.1.2 Installation inside the control panel.....	11
3.1.3 Cables.....	13
3.1.4 Power supply module.....	21
3.1.5 Ferrite core.....	21
3.1.6 Noise filter (power supply line filter).....	22
3.1.7 Power line for external power supply terminal.....	23
3.1.8 Installation environment of the CC-Link/LT module and the AS-I module .....	23
3.2 Requirements for Compliance with Low Voltage Directive.....	24
3.2.1 Standard applied for MELSEC-AnS series programmable controller .....	24
3.2.2 Precautions when using the MELSEC-AnS series programmable controller .....	25
3.2.3 Power supply .....	26
3.2.4 Control panel.....	26
3.2.5 Module installation .....	28
3.2.6 External wiring .....	28
4. LOADING AND INSTALLATION .....	29
4.1 Module Installation .....	29
4.1.1 Handling instructions.....	29
4.1.2 Instructions for mounting the base unit.....	31
4.1.3 Installation and removal of dustproof cover .....	34
4.1.4 Installation and removal of modules .....	35
4.1.5 Setting the extension number of the extension base unit .....	39
4.1.6 Connection and disconnection of extension cable.....	41
4.2 Fail-Safe Circuit Concept .....	44
4.3 Wiring .....	48
4.3.1 Power supply module specifications .....	48
4.3.2 The precautions on the wiring.....	51
4.3.3 Connecting to the power supply module .....	55

4.4 Precautions when Connecting the Uninterruptible Power Supply (UPS)	56
4.5 Part Names and Settings of the CPU Module	57
4.5.1 Part names and settings	57
4.5.2 Switch operation after program write	60
4.5.3 Latch clear operation	60
4.5.4 Installation and removal of memory card during power-on	60
5. SPECIFICATIONS AND CONNECTIONS OF I/O MODULES	62
5.1 Input modules	62
5.1.1 Input module specifications	62
5.1.2 Input module connections	66
5.2 Output modules	72
5.2.1 Output module specifications	72
5.2.2 Output module connections	78
5.3 Input/output combined modules	88
5.3.1 Input/output combined module specifications	88
5.3.2 Input/output composite module connections	90
6. ERROR CODES	92
6.1 Reading the Error Code	92
6.2 Error Code List	93
7. TRANSPORTATION PRECAUTIONS	113
7.1 Relevant Models	113
7.2 Transportation Guidelines	113

## ABOUT THE MANUALS

The following manuals are related to this product.

Referring to this list, please request the necessary manuals.

### Detailed manual

Manual name	Manual Number (Model code)
QCPU-A (A mode) User's Manual This manual describes information on the performance, functions and handling of the QCPU-A (A mode) and on the specifications and handling of the memory cassettes, power supply modules and base units. (Sold separately)	SH-080065 (13JR10)

### Related Manuals

Manual name	Manual Number (Model code)
Type ACPU/QCPU-A (A Mode) Programming Manual (Fundamentals) This manual describes programming methods required to create programs, device names, parameters, types of program, configuration of the memory area, etc. (Sold separately)	IB-66249 (13J740)
Type ACPU/QCPU-A (A Mode) Programming Manual (Common Instructions) This manual describes how to use the sequence instructions, basic instructions, application instructions and micro-computer programs. (Sold separately)	IB-66250 (13J741)
Type AnSHCPU/AnACPU/AnUCPU/QCPU-A (A Mode) Programming Manual (Dedicated Instructions) This manual describes the extended instructions for the A2ASCPU(S1/30). (Sold separately)	IB-66251 (13J742)
Type AnACPU/AnUCPU (AD57 control Instructions) Programming Manual This manual describes the dedicated instructions used to control AD57(S1)/ AD58 CRT/LCD control modules with an A2ASCPU(S1/30). (Sold separately)	IB-66257 (13J743)



Manual name	Manual Number (Model code)
Type AnACPU/AnUCPU/QCPU-A (A mode) Programming Manual (PID control instructions) This manual describes the dedicated instructions used to execute PID control with an A2ASCPU(S1/30). (Sold separately)	IB-66258 (13J744)
Type MELSAP-II (SFC) Programming Manual Describes the specifications, functions, instructions, and programming methods for SFC programming using MELSAP II. (Sold separately)	IB-66361 (13JF40)
AnS Module Type I/O User's Manual This manual gives the specifications for AnS module type I/O modules. (Sold separately)	IB-66541 (13JE81)

## USER PRECAUTIONS

### PRECAUTIONS WHEN USING THE Q SERIES

For a new CPU module, which has never used before, the contents of built-in RAM and device data are undefined.

Make sure to clear the built-in RAM memory (PC memory all clear) in the CPU module by peripheral devices and operate latch clear by RUN/STOP key switches.

### PRECAUTIONS FOR BATTERY

- (1) The operation after a battery is unmounted and the programmable controller is stored.

When reoperating after a battery is uncounted and the programmable controller is stored, the contents of built-in RAM and device data may be undefined. For this reason, make sure to clear the built-in RAM memory (PC memory all clear) in the CPU module by peripheral devices and operate latch clear by RUN/STOP key switch before start the operation again.

- (2) If a battery exceeded its guaranteed life is stored and reoperated. If a battery exceeded its guaranteed life is stored and reoperated, the contents of built-in RAM and device data may be undefined. For this reason, make sure to clear the built-in RAM memory (PC memory all clear) in the CPU module by peripheral devices and operate latch clear by RUN/STOP key switches before start the operation again.

After the built-in RAM clear and latch clear of the CPU module, write the backed-up memory contents to the CPU module before saving.

POINT
-------

Make sure to back-up each memory contents before storing the programmable controller.
---

- \* Refer to the following manuals for details of built-in RAM clear (programmable controller memory all clear) by peripheral devices.

- GX Developer Operating Manual
- A6GPP/A6PHP Operating Manual
- SW□SRX/SW□NX/SW□IVD-GPPA Operating Manual

Refer to Section 4.5.3 for latch clear operation by RUN/STOP key switch of the CPU module.

# 1. OVERVIEW

This user's manual provides the performance specifications, loading and installation, part names and settings, I/O module specifications and installation, and error code reading method of the Q02CPU-A, Q02HCPU-A and Q06HCPU-A (hereinafter referred to as the "QCPU-A").

## 1.1 Supplied Parts

The following tables list the parts packed with the corresponding modules.

### (1) CPU module

Product Name	Type	Quantity
CPU module	Q02CPU-A	1
	Q02HCPU-A	
	Q06HCPU-A	
Battery	Q6BAT	1

### (2) Main base unit for A series modules

Product Name	Type	Quantity
Main base unit	QA1S33B	1
	QA1S35B	
	QA1S38B	
Base unit mounting screw	M5 screw	4
Dustproof cover	_____	1
This manual	_____	1

### (3) Extension base unit for A series modules

Product Name	Type	Quantity
Extension base unit	QA1S51B	1
	QA1S65B	
	QA1S68B	
Base unit mounting screw	M5 screw	3/4 <sup>*1</sup>
Supplementary Description for QA1S51B Extension Base Unit (BCN-P5920) <sup>*2</sup>	_____	1
Dustproof cover <sup>*2</sup>	_____	

\*1 Screws as many as the number of mounting holes are supplied.

\*2 This document is included only with the QA1S5□B.

(4) Power supply module

Product Name	Type	Quantity
Power supply module	A1S61PN	1
	A1S62PN	
	A1S63P	

## 2. GENERAL SPECIFICATIONS

### 2.1 General Specifications

This section provides specifications common to various modules used.

General Specification

Item	Specifications					
Ambient operating temperature <i>Température ambiante de fonctionnement</i>	0 to 55 °C 0 à 55 °C					
Ambient storage temperature	-20 to 75 °C					
Ambient operating humidity	10 to 90 % RH, No-condensing					
Ambient storage humidity	10 to 90 % RH, No-condensing					
Vibration resistance *4	Compliant with JIS B 3502, IEC 61131-2	Under intermittent vibration	Frequency	Acceleration	Amplitude	Sweep count
			5 to 9Hz	————	3.5mm (0.138in.)	10 times each in X, Y, Z directions
		9 to 150Hz	9.8m/s <sup>2</sup>	————		
		Under continuous vibration	5 to 9Hz	————	1.75mm (0.069in.)	————
		9 to 150Hz	4.9m/s <sup>2</sup>	————		
Shock resistance	Compliant with JIS B 3502, IEC 61131-2 (147 m/ s <sup>2</sup> , 3 times in each of 3 directions X Y Z)					
Operating ambience	No corrosive gases					
Operating altitude *3	0 to 2000m					
Installation location	Control panel					
Over voltage category *1	II max.					
Pollution level *2	2 max.					
Equipment category	Class I					

\*1 This indicates the section of the power supply to which the equipment is assumed to be connected between the public electrical power distribution network and the machinery within premises. Category II applies to equipment for which electrical power is supplied from fixed facilities. The surge voltage withstand level for up to the rated voltage of 300V is 2500V.

- \*2 This index indicates the degree to which conductive material is generated in terms of the environment in which the equipment is used. Pollution level 2 is when only non-conductive pollution occurs. A temporary conductivity caused by condensing must be expected occasionally.
- \*3 Do not use or store the programmable controller under pressure higher than the atmospheric pressure of altitude 0m. Doing so can cause a malfunction.  
When using the programmable controller under pressure, please contact your sales representative.
- \*4 When an A series extension base unit (A52B, A55B, A58B, A62B, A65B, A68B) is used in the system, the following specifications apply.

	Frequency	Acceleration	Amplitude	Sweep count
Under intermittent vibration	10 to 57Hz	———	0.075mm (0.003in.)	10 times each in X, Y, Z directions
	57 to 150Hz	9.8m/s <sup>2</sup>	———	
Under continuous vibration	10 to 57Hz	———	0.035mm (0.001in.)	———
	57 to 150Hz	4.9m/s <sup>2</sup>	———	

## 2.2 Performance Specifications of CPU Modules

This section gives the performance specifications of the CPU modules.

Performance List

Item		Type		Remarks
		Q02CPU-A	Q02HCPU-A	
Control system		Repeated operation using stored program		
I/O control method		Refresh mode		Partial direct I/O possible depending on instruction
Programming language		Language dedicated to sequence control		
		Relay symbol type and logic symbolic language, MELSAP-II (SFC)		
Processing speed (sequence instruction)	LD	0.079 $\mu$ s/ steps	0.034 $\mu$ s/steps	
	MOV	0.474 $\mu$ s/ steps	0.204 $\mu$ s/steps	
Constant scan		10 to 190 ms (can be specified in 10ms increments)		Set to special register D9020
Memory capacity	Built-in RAM	144k bytes		
	When using memory card (RAM)	448k bytes		
	Built-in ROM	144k bytes		
Program capacity	Main sequence program	Max. 28k steps	Max. 30k steps	Parameter setting
	Sub sequence program	Unavailable	Max. 30k steps	
I/O device points		8192 points (X/Y0 to 1FFF) (Total points available on programs including remote I/O)		
I/O points		4096 points (X/Y0 to FFF) (Points can be controlled on basic and expansion base modules)		
Output mode switching at STOP $\rightarrow$ RUN		Re-output of operation at time of STOP (default)/output after operation execution		Parameter setting
Self-diagnostics functions		Watchdog error monitor (watchdog timer fixed to 200ms) Memory, CPU, I/O, battery and other error detection		
Operation mode at error occurrence		STOP/CONTINUE selection		Parameter setting
Starting method at RUN		Initial start (Automatic restart made when "RUN" switch of CPU is moved to ON position at power-on or at power restoration after power failure)		

## Performance List (Continued)

Item	Type			Remarks
	Q02CPU-A	Q02HCPU-A	Q06HCPU-A	
Latch (power failure compensation) range	Defaults to L1000 to L2047 (Latch range can be set for L, B, T, C, D and W)			Set range in parameters
Remote RUN/PAUSE contact	One RUN contact and one PAUSE contact can be set within the range from X0 to X1FFF.			Parameter setting
Clock function	Year, month, day, hour, minute, second, day of week (Automatically recognizes leap years.) Accuracy -3.18 to +5.25s(TYP.+2.12s)/d at 0°C -3.93 to +5.25s(TYP.+1.90s)/d at 25°C -14.69 to +3.53s(TYP.-3.67s)/d at 55°C			
Allowable momentary power interruption time	Depends on power supply module			
5VDC internal current consumption	0.60A	0.64A	0.64A	
Weight	0.20kg	0.20kg	0.20kg	
External dimensions	98(3.86)(H)×27.4(1.08)(W)×89.3(3.52)(D) mm(inches)			

### CAUTION

When using the conventional type peripheral device and GPP function software package, set the programmable controller type to "Q02(H)-A/Q06H-A".

When the GPP used is incompatible with the "Q02(H)-A/Q06H-A", make the following setting.

GPP- Compatible CPU	"Q02(H)-A/Q06H-A"- Incompatible	"A4UCPU"- Incompatible	"A3ACPU"- Incompatible
Programmable controller type	A4UCPU	A3ACPU	A3HCPU

Note that the setting of the programmable controller type to "A3ACPU" or "A3HCPU" will limit the usable ranges of the devices.



## 2.3 Specifications of Base Units

### (1) Main Base Unit

Item \ Type	QA1S33B	QA1S35B	QA1S38B
Number of I/O modules accepted	3	5	8
5VDC internal current consumption	0.107A	0.117A(0.086A) *	0.118A(0.086A) *
External dimensions	255(10.04)(W)× 130(5.12)(H)× 51.2(2.02)(D) mm(inches)	325(12.80)(W)× 130(5.12)(H)× 51.2(2.02)(D) mm(inches)	430(16.93)(W)× 130(5.12)(H)× 51.2(2.02)(D) mm(inches)
Weight	0.57kg	0.75kg	1.00kg

\* The parenthesized values are for those products not provided for CE mark.

### (2) Extension Base Unit

Item \ Type	QA1S51B	QA1S65B	QA1S68B
Number of I/O modules accepted	1	5	8
5VDC internal current consumption	0.12A	0.117A(0.088A) *	0.118A(0.090A) *
External dimensions	100(3.94)(W)× 130(5.12)(H)× 50.7(2.00)(D) mm(inches)	315(12.40)(W)× 130(5.12)(H)× 51.2(2.02)(D) mm(inches)	420(16.54)(W)× 130(5.12)(H)× 51.2(2.02)(D) mm(inches)
Weight	0.23kg	0.75kg	1.00kg

\* The parenthesized values are for those products not provided for CE mark.

---

---

### **3. EMC DIRECTIVES AND LOW VOLTAGE DIRECTIVES**

---

---

The products sold in the European countries have been required by law to comply with the EMC Directives and Low Voltage Directives of the EU Directives since 1996 and 1997, respectively.

The manufacturers must confirm by self-declaration that their products meet the requirements of these directives, and put the CE mark on the products.

(1) Authorized representative in Europe

Authorized representative in Europe is shown below.

Name : Mitsubishi Electric Europe BV

Address: Gothaer Strasse 8, 40880 Ratingen, Germany

#### **3.1 Requirements for Compliance with EMC Directive**

The EMC Directives specifies emission and immunity criteria and requires the products to meet both of them, i.e., not to emit excessive electromagnetic interference (emission): to be immune to electromagnetic interference outside (immunity).

Guidelines for complying the machinery including MELSEC-Q series programmable controller with the EMC Directives are provided in Section 3.1.1 to 3.1.8 below.

The guidelines are created based on the requirements of the regulations and relevant standards, however, they do not guarantee that the machinery constructed according to them will not comply with the Directives.

Therefore, the manufacturer of the machinery must finally determine how to make it comply with the EMC Directives: if it is actually compliant with the EMC Directives.

### 3.1.1 Standards applicable to the EMC Directive

#### (1) Regulations regarding emission

Standard	Test item	Test description	Value specified in standard
EN61131-2: 2007	CISPR16-2-3 Radiated emission *2	Radio waves from the product are measured.	<ul style="list-style-type: none"><li>• 30M-230MHz QP: 40dB<math>\mu</math>V/m (10m in measurement range) *1</li><li>• 230M-1000MHz QP: 47dB<math>\mu</math>V/m (10m in measurement range)</li></ul>
	CISPR16-2-1, CISPR16-1-2 Conducted emission *2	Noise from the product to the power line is measured.	<ul style="list-style-type: none"><li>• 150k-500kHz QP: 79dB, Mean: 66dB *1</li><li>• 500k-30MHz QP: 73dB, Mean: 60dB</li></ul>

\*1 QP: Quasi-peak value, Mean: Average value

\*2 Programmable controllers are open-type devices (devices designed to be housed inside other equipment) and must be installed inside a conductive control panel. The corresponding tests were conducted with the programmable controller installed inside a control panel.

## (2) Regulations regarding immunity

Standard	Test item	Test description	Value specified in standard
EN61131-2: 2007	EN61000-4-2 Electrostatic discharge immunity *1	Immunity test in which electrostatic is applied to the cabinet of the equipment.	<ul style="list-style-type: none"> <li>• 8kV Air discharge</li> <li>• 4kV Contact discharge</li> </ul>
	EN61000-4-3 Radiated, radio- frequency, electromagnetic field immunity *1	Immunity test in which electric fields are irradiated to the product.	<ul style="list-style-type: none"> <li>• 80% AM modulation@1kHz</li> <li>• 80M-1000MHz: 10V/m</li> <li>• 1.4G-2.0GHz: 3V/m</li> <li>• 2.0G-2.7GHz: 1V/m</li> </ul>
	EN61000-4-4 Electrical fast transient/burst immunity *1	Immunity test in which burst noise is applied to the power line and signal line.	<ul style="list-style-type: none"> <li>• AC/DC main power, I/O power, AC I/O (unshielded): 2kV</li> <li>• DC I/O, analog, communication: 1kV</li> </ul>
	EN61000-4-5 Surge immunity *1	Immunity test in which lightning surge is applied to the power line and signal line.	<ul style="list-style-type: none"> <li>• AC power line, AC I/O power, AC I/O (unshielded) : 2kV CM, 1kV DM</li> <li>• DC power line, DC I/O power : 0.5kV CM, DM</li> <li>• DC I/O, AC I/O (shielded), analog<sup>2</sup>, communication: 1kV CM</li> </ul>
	EN61000-4-6 Immunity to conducted disturbances, induced by radio- frequency fields *1	Immunity test in which high frequency noise is applied to the power line and signal line	0.15M-80MHz, 80% AM modulation@1kHz, 10Vrms
EN61131-2: 2007	EN61000-4-8 Power-frequency magnetic field immunity *1	Immunity test in which the product is installed in inductive magnetic field	50Hz/60Hz, 30A/m
	EN61000-4-11 Voltage dips and interruption immunity	Immunity test in which power supply voltage is momentarily interrupted	<ul style="list-style-type: none"> <li>• Apply at 0%, 0.5 cycles and zero-cross point</li> <li>• 0%, 250/300 cycles (50/60Hz)</li> <li>• 40%, 10/12 cycles (50/60Hz)</li> <li>• 70%, 25/30 cycles (50/60Hz)</li> </ul>

\*1 Programmable controllers are open-type devices (devices designed to be housed inside other equipment) and must be installed inside a conductive control panel. The corresponding tests were conducted with the programmable controller installed inside a control panel.

\*2 The accuracy of an analog-digital converter module may temporary vary within  $\pm 10\%$ .

### 3.1.2 Installation inside the control panel

The programmable controller is open equipment and must be installed within a control panel for use.\* This not only ensures safety but also ensures effective shielding of programmable controller-generated electromagnetic noise.

\* Also, each network remote station needs to be installed inside the control panel.

However, the waterproof type remote station can be installed outside the control panel.

- (1) Control panel
  - (a) Use a conductive control panel.
  - (b) When attaching the control panel's top plate or base plate, mask painting and weld so that good surface contact can be made between the panel and the bolt.
  - (c) To ensure good electrical contact with the control panel, mask the paint on the installation bolts of the inner plate in the control panel so that contact between surfaces can be ensured over the widest possible area.
  - (d) Earth the control panel with a thick wire so that a low impedance connection to ground can be ensured even at high frequencies.
  - (e) Holes made in the control panel must be 10 cm (3.94 in.) diameter or less. If the holes are 10 cm (3.94 in.) or larger, radio frequency noise may be emitted.
  
- (2) Connection of power and earth wires

Earthing and power supply wires for the programmable controller system must be connected as described below.

  - (a) Provide an earthing point near the power supply module. Earth the power supply's LG and FG terminals (LG : Line Ground, FG : Frame Ground) with the thickest and shortest wire possible. (The wire length must be 30 cm (11.18 in.) or shorter.) The LG and FG terminals function is to pass the noise generated in the programmable controller system to the ground, so an impedance that is as low as possible must be ensured. As the wires are used to relieve the noise, the wire itself carries a large noise content and thus short wiring means that the wire is prevented from acting as an antenna.

- (b) The earth wire led from the earthing point must be twisted with the power supply wires. By twisting with the earthing wire, noise flowing from the power supply wires can be relieved to the earthing. However, if a filter is installed on the power supply wires, the wires and the earthing wire may not need to be twisted.

### 3.1.3 Cables

The cables extracted from the control panel contain a high frequency noise component. On the outside of the control panel, therefore, they serve as antennas to emit noise. To prevent noise emission, use shielded cables for the cables which are connected to the I/O modules and intelligent function modules and may be extracted to the outside of the control panel.

The use of a shielded cable also increases noise resistance.

The signal lines (including common line) of the programmable controller, which are connected to I/O modules, intelligent function modules and/or extension cables, have noise durability in the condition of grounding their shields by using the shielded cables. If a shielded cable is not used or not grounded correctly, the noise resistance will not meet the specified requirements.

#### (1) Shield grounding

- (a) When grounding the shield, position the grounding point closer to the module and take care so that the electromagnetic induction will not occur between the grounded cable and ungrounded one.
- (b) When grounding the shield, strip a part of the outer insulation layer to expose the shield, and make the shield contact with the control panel in the largest area as possible. The clamp fitting as shown below can be used. In this case, however, the contact area on the panel's inner surface must be masked during painting.

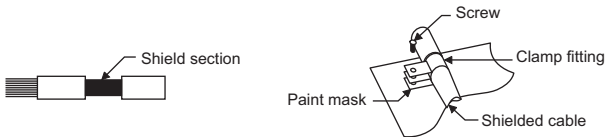

Note) The method of earthing by soldering a wire onto the shield section of the shielded cable as shown below is not recommended. The high frequency impedance will increase and the shield will be ineffective.

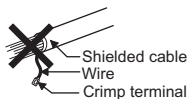

(2) MELSECNET (II) and MELSECNET/10 modules

- (a) Use a double-shielded coaxial cable for the MELSECNET module which uses coaxial cables such as A1SJ71AR21, A1SJ71LR21 and A1SJ71BR11. Noise in the range of 30 MHz or higher in radiation noise can be suppressed by the use of double-shielded coaxial cables (manufactured by MITSUBISHI CABLE INDUSTRIES, LTD: 5C-2V-CCY). Earth the outer shield to the ground.

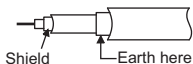

For the shield grounding, refer to item (1).

- (b) Make sure to attach a ferrite core to the double-shielded coaxial cable connected to the MELSECNET module. In addition, position the ferrite core on each cable near the outlet of the control panel. The ferrite core manufactured by TDK Corporation, ZCAT3035-1330, is recommended.
- (3) Ethernet module

Precautions for using AUI cables, twisted pair cables and coaxial cables are described below.

- (a) Always earth the AUI cables<sup>\*1</sup> connected to the 10BASE5 connectors. Because the AUI cable is of the shielded type, strip part of the outer cover and earth the exposed shield section to the ground on the widest contact surface as shown below.

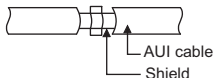

Refer to (1) for the earthing of the shield.

<sup>\*1</sup> Make sure to install a ferrite core for the cable.

The ferrite core manufactured by TDK Corporation, ZCAT2032-0930, is recommended.



- (b) Use shielded twisted pair cables as the twisted pair cables connected to the 10BASE-T connectors. For the shielded twisted pair cables, strip part of the outer cover and earth the exposed shield section to the ground on the widest contact surface as shown below.

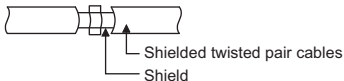

Refer to (1) for the earthing of the shield.

- (c) Always use double-shielded coaxial cables as the coaxial cables<sup>\*2</sup> connected to the 10BASE2 connectors. Earth the double-shielded coaxial cable by connecting its outer shield to the ground.

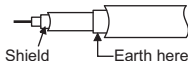

Refer to (1) for the earthing of the shield.

- <sup>\*2</sup> Make sure to install a ferrite core for the cable.  
The ferrite core manufactured by TDK Corporation, ZCAT3035-1330, is recommended.

**Ethernet is a registered trademark of Xerox Corporation in the USA.**

- (4) I/O and other communication cables  
For the I/O signal lines (including common line) and other communication cables (RS-232, RS-422 etc), if extracted to the outside of the control panel, also ensure to earth the shield section of these lines and cables in the same manner as in item (1) above.

## (5) Positioning Modules

Precautions to be followed when the machinery conforming to the EMC Directive is configured using the A1SD75P□-S3 are described below.

### (a) When wiring with a 2 m (6.56 ft.) or less cable

- Ground the shield section of the external wiring cable with the cable clamp.  
(Ground the shield at the closest location to the A1SD75 external wiring connector.)
- Wire the external wiring cable to the drive unit and external device with the shortest practicable length of cable.
- Install the drive unit in the same panel.

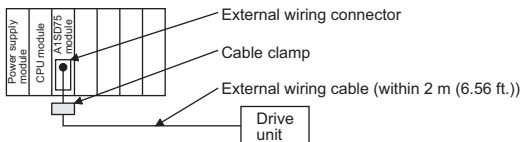

### (b) When wiring with cable that exceeds 2 m (6.56 ft.), but is 10 m (32.81 ft.) or less

- Ground the shield section of the external wiring cable with the cable clamp.  
(Ground the shield at the closest location to the A1SD75 external wiring connector.)
- Install a ferrite core.
- Wire the external wiring cable to the drive unit and external device with the shortest practicable length of cable.

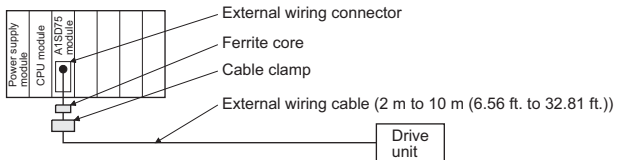

(c) Ferrite core and cable clamp types and required quantities

- Cable clamp  
Type : AD75CK (manufactured by Mitsubishi Electric Corporation)
- Ferrite core  
Type : ZCAT3035-1330 (manufactured by TDK Corporation)  
Contact: TDK Corporation
- Required quantity

Cable length	Prepared part	Required Qty		
		1 axis	2 axes	3 axes
Within 2 m (6.56 ft.)	AD75CK	1	1	1
2 m (6.56 ft.) to 10m (32.81 ft.)	AD75CK	1	1	1
	ZCAT3035-1330	1	2	3

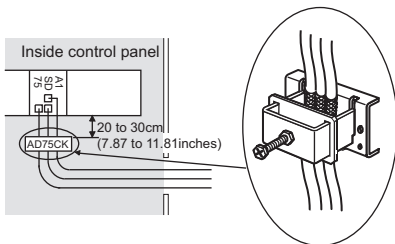

(6) CC-Link Module

- (a) Be sure to ground the cable shield that is connected to the CC-Link module close to the exit of control panel or to any of the CC-Link stations within 30 cm (11.8 in.) from the module or stations.

The CC-Link dedicated cable is a shielded cable. As shown in the illustration below, remove a portion of the outer covering and ground as large a surface area of the exposed shield part as possible.

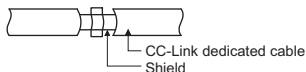

- (b) Always use the specified CC-Link dedicated cable.
- (c) The CC-Link module, the CC-Link stations and the FG line inside the control panel should be connected at the FG terminal as shown in the diagram below.

[Simplified diagram]

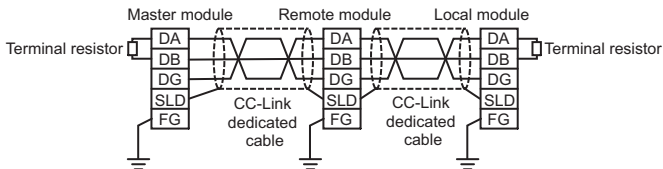

- (d) Each power line connecting to the external power supply terminal or module power supply terminal must be 30m (98.43 ft) or less.
- (e) Install a noise filter to the external power supply. Use a noise filter with an attenuation characteristic equivalent to that of the MA1206 (TDK-Lambda Corporation). Note that a noise filter is not required when the module is used in Zone A defined in EN61131-2.

- (f) Keep the length of signal cables connected to the analog input terminals of the following modules to 30m or less.  
Wire cables connected to the external power supply and module power supply terminal in the control panel where the module is installed.
- AJ65BT-64RD3
  - AJ65BT-64RD4
  - AJ65BT-68TD
- (g) For the cable connected to the power supply terminal of the AJ65SBT-RPS, AJ65SBT-RPG or AJ65BT-68TD, attach a ferrite core with an attenuation characteristic equivalent to that of the ZCAT3035- 1330 from TDK Corporation. Twist the cable around the ferrite core by one as shown below.

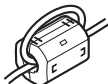

- (h) To supply the module power supply terminal of the AJ65BTB2-16R/16DR, AJ65SBTB2N-8A/8R/8S/16A/16R/16S with power using the AC/DC power supply, follow as shown below.
- Install the AC/DC power supply in the control panel where the module is installed.
  - Use a CE-marked AC/DC power supply and ground the FG terminals. (The AC/DC power supply used for the tests conducted by Mitsubishi: TDK-Lambda Corporation: DLP-120-24-1)
  - For the cable connected to the AC input terminal and DC output terminals of the AC/DC power supply, attach a ferrite core. Twist the cable around the ferrite core by one as shown below. (Ferrite core used for the tests conducted by Mitsubishi: NEC TOKIN Corporation: ESD-SR-250)

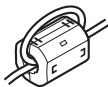

(7) CC-Link/LT module

To supply the CL2DA2-B and CL2AD4-B with 24VDC power using the CL1PAD1, keep the length of the power cable from the CL1PAD1 to the 24VDC power supply to 30m (98.43ft) or less.

(8) Measures against static electricity

When using an insulation displacement connector without connector cover, a connected cable for the connector is thin in applicable wire size and coating. Therefore, note that the module may cause an electric discharge failure.

As measures against the failure, using pressure-displacement type connector whose applicable wire size is thick or soldering type connector is recommended.

### 3.1.4 Power supply module

The precautions required for each power supply module are described below. Always observe the items noted as precautions.

Model	Precautions <sup>*2</sup>
A1S61PN, A1S62PN	Make sure to short the LG and FG terminals with a cable of 6 to 7cm and ground the cable.
A1S63P <sup>*1</sup>	Use the 24VDC panel power equipment conforming to the EU Directive.
A1SJHCPU(S8)	Make sure to short and ground the LG and FG terminals. <sup>*2</sup>

\*1 Filter attachment to the power cable is not required for the A1S63P product with the version (F) and later. However, use the 24VDC panel power equipment that conforms to the CE.

\*2 Make sure to attach two ferrite cores to the power line.

Attach them as close to the power supply module as possible.

Use a ferrite core whose damping characteristic is equivalent to that of the RFC-H13 produced by KITAGAWA INDUSTREIS CO., LTD.

### 3.1.5 Ferrite core

Use of ferrite cores is effective in reducing the conduction noise in the band of about 10 MHz and radiated noise in 30 to 100 MHz band.

It is recommended to attach ferrite cores when the shield of the shielded cable coming out of control panel does not work effectively, or when emission of the conduction noise from the power line has to be suppressed.

We tested using ferrite cores from TDK Corporation, ZCAT3035-1330 and ZCAT2032-0930, and RFC-H13 from KITAGAWA INDUSTREIS CO., LTD.

Make sure to attach a ferrite core to a cable at the position closest to the outlet of control panel as possible. If attached at an improper position, the ferrite core will not work effectively.

- Ferrite core

Type : ZCAT3035-1330, ZCAT2032-0930

Contact : TDK Corporation

Type : RFC-H13

Contact : KITAGAWA INDUSTREIS CO., LTD

### 3.1.6 Noise filter (power supply line filter)

A noise filter is a component which has an effect on conducted noise. With the exception of some models, it is not required to fit the noise filter to the power supply line, but fitting it can further suppress noise. (The noise filter has the effect of reducing conducted noise of 10 M Hz or less.) Use any of the following noise filters (double  $\pi$  type filters) or equivalent.

Model name	FN343-3/01	FN660-6/06	ZHC2203-11
Manufacturer	SCHAFFNER	SCHAFFNER	TDK
Rated current	3 A	6 A	3 A
Rated voltage	250 V		

The precautions required when installing a noise filter are described below.

- (1) Do not bundle the wires on the input side and output side of the noise filter. When bundled, the output side noise will be induced into the input side wires from which the noise was filtered.

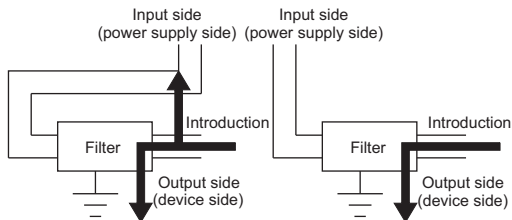

- (a) The noise will be included when the input and output wires are bundled.
  - (b) Separate and lay the input and output wires.
- (2) Earth the noise filter earthing terminal to the control panel with the shortest wire possible (approx. 10 cm (3.94 in.)).



### 3.1.7 Power line for external power supply terminal

Use a CE-marked AC/DC power supply for an external power supply of the modules, and the power cable length needs to be less than 30m (98.43 ft.).\*1

\*1 The power cable length for the A1SJ71E71N-B5 needs to be less than 3m (9.84 ft.).

Install noise filters to external supply power terminals of the I/O module and the modules below.

Use noise filters whose damping characteristic is equivalent to that of the MA1206 produced by TDK Lambda Corporation.

- Analog-digital converter module
- Digital-analog converter module
- Analog I/O module
- Temperature input module
- Temperature control module
- Pulse input module
- High-speed counter module
- Positioning module

### 3.1.8 Installation environment of the CC-Link/LT module and the AS-I module

#### (1) CC-Link/LT module

Use the module under the environment of Zone A\*1.

For the categories of the following products, refer to the manual came with each product.

- CL1Y4-R1B1
- CL1Y4-R1B2
- CL1XY4-DR1B2
- CL1XY8-DR1B2
- CL1PSU-2A

#### (2) AS-i module

Use the module under the environment of Zone A\*1.

\*1 Zone defines categories according to industrial environment, specified in the EMC and Low Voltage Directives, EN61131-2.

Zone C: Factory mains (isolated from public mains by dedicated transformer)

Zone B: Dedicated power distribution, secondary surge protection (rated voltage: 300V or less)

Zone A: Local power distribution, protected from dedicated power distribution by AC/DC converter and insulation transformer (rated voltage: 120V or less)

## **3.2 Requirements for Compliance with Low Voltage Directive**

The Low Voltage Directives apply to the electrical equipment operating from 50 to 1000VAC or 75 to 1500VDC; the manufacturer must ensure the adequate safety of the equipment.

Guidelines for installation and wiring of MELSEC-AnS series programmable controller are provided in Section 3.2.1 to 3.2.7 for the purpose of compliance with the EMC Directives.

The guidelines are created based on the requirements of the regulations and relevant standards, however, they do not guarantee that the machinery constructed according to them will comply with the Directives.

Therefore, the manufacturer of the machinery must finally determine how to make it comply with the EMC Directives: if it is actually compliant with the EMC Directives.

### **3.2.1 Standard applied for MELSEC-AnS series programmable controller**

The standard applied for MELSEC-AnS series programmable controller is EN61010-1 safety of devices used in measurement rooms, control rooms, or laboratories.

For the modules which operate with the rated voltage of 50 VAC/75 VDC or above, we have developed new models that conform to the above standard.

For the modules which operate with the rated voltage under 50 VAC/75 VDC, the conventional models can be used, because they are out of the low-voltage directive application range.

### 3.2.2 Precautions when using the MELSEC-AnS series programmable controller

#### Module selection

- (1) Power module  
For a power module with rated input voltage of 100/200 VAC, select a model in which the internal part between the first order and second order is intensively insulated, because it generates hazardous voltage (voltage of 42.4 V or more at the peak) area.  
For a power module with 24 VDC rated input, a conventional model can be used.
- (2) I/O module  
For I/O module with rated input voltage of 100/200 VAC, select a model in which the internal area between the first order and second order is intensively insulated, because it has hazardous voltage area.  
For I/O module with 24 VDC rated input, a conventional model can be used.
- (3) CPU module, memory card, base unit  
Conventional models can be used for these modules, because they only have a 5 VDC circuit inside.
- (4) Special function module  
Conventional models can be used for the special function modules including analog module, network module, and positioning module, because the rated voltage is 24 VDC or smaller.
- (5) Display device  
Use the CE marked product.

### 3.2.3 Power supply

The insulation specification of the power module was designed assuming installation category II. Be sure to use the installation category II power supply to the programmable controller.

The installation category indicates the durability level against surge voltage generated by a thunderbolt. Category I has the lowest durability; category IV has the highest durability.

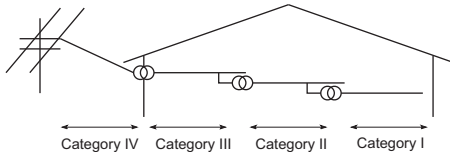

Figure 1. : Installation Category

Category II indicates a power supply whose voltage has been reduced by two or more levels of isolating transformers from the public power distribution.

### 3.2.4 Control panel

Because the programmable controller is an open device (a device designed to be stored within another module), be sure to use it after storing in the control panel.\*

\* Also, each network remote station needs to be installed inside the control panel.

However, the waterproof type remote station can be installed outside the control panel.

#### (1) Electrical shock prevention

In order to prevent persons who are not familiar with the electric facility such as the operators from electric shocks, the control panel must have the following functions :

- (a) The control panel must be equipped with a lock so that only the personnel who has studied about the electric facility and have enough knowledge can open it.
- (b) The control panel must have a structure which automatically stops the power supply when the box is opened.
- (c) For electric shock protection, use IP20 or greater control panel.

(2) Dustproof and waterproof features

The control box also has the dustproof and waterproof functions. Insufficient dustproof and waterproof features lower the insulation withstand voltage, resulting in insulation destruction. The insulation in our programmable controller is designed to cope with the pollution level 2, so use in an environment with pollution level 2 or below.

Pollution level 1: An environment where the air is dry and conductive dust does not exist.

Pollution level 2: An environment where conductive dust does not usually exist, but occasional temporary conductivity occurs due to the accumulated dust. Generally, this is the level for inside the control box equivalent to IP54 in a control room or on the floor of a typical factory.

Pollution level 3: An environment where conductive dust exists and conductivity may be generated due to the accumulated dust.

An environment for a typical factory floor.

Pollution level 4: Continuous conductivity may occur due to rain, snow, etc. An outdoor environment.

As shown above, the programmable controller can realize the pollution level 2 when stored in a control panel equivalent to IP54.

### 3.2.5 Module installation

- (1) Installing modules contiguously  
In AnS series programmable controllers, the left side of each I/O module is left open. When installing an I/O module to the base, do not make any open slots between any two modules. If there is an open slot on the left side of a module with 100/200 VAC rating, the printed board which contains the hazardous voltage circuit becomes bare. When it is unavoidable to make an open slot, be sure to install the blank module (A1SG60).

### 3.2.6 External wiring

- (1) Module power supply and external power supply  
For the remote module which requires 24VDC as module power supply, the 5/12/24/48VDC I/O module, and the intelligent function module (special function module) which requires the external power supply, use the 5/12/24/48VDC circuit which is doubly insulated from the hazardous voltage circuit or use the power supply whose insulation is reinforced.
- (2) External devices  
When a device with a hazardous voltage circuit is externally connected to the programmable controller, use a model whose circuit section of the interface to the programmable controller is intensively insulated from the hazardous voltage circuit.
- (3) Intensive insulation  
Intensive insulation refers to the insulation with the dielectric withstand voltage shown below.

Intensive Insulation Withstand Voltage  
(Installation Category II, source : IEC664)

Rated voltage of hazardous voltage area	Surge withstand voltage (1.2/50 $\mu$ s)
150 VAC or below	2500 V
300 VAC or below	4000 V

---

---

## 4. LOADING AND INSTALLATION

---

---

### 4.1 Module Installation

#### 4.1.1 Handling instructions

The precautions when using the CPU, I/O module, special function module, power supply module and base unit are provided below.

- (1) Do not drop or allow any impact to the module case, memory card, terminal block connector, or pin connector.
- (2) Do not remove the printed-circuit board from the module case. Doing so may cause failure.
- (3) Use caution to prevent foreign matter, such as wire chips, from entering the module during wiring.  
If any foreign matter has entered the module, remove it.
- (4) When using the extension base unit (QA1S6□B), be sure to install the power supply module. Although modules with light load may operate without the power supply module, stable operation is not guaranteed.
- (5) Tighten the screws such as module fixing screws within the following ranges.

Screw	Tightening Torque
QCPU-A module fixing screw (M3×12)	36 to 48 N•cm
AnS series module mounting screw (M4)	78 to 118 N•cm
I/O module terminal block mounting screw (M3.5)	59 to 88 N•cm
Power supply module terminal screw (M3.5)	

- (6) When using extension cables, do not install them together with the main circuit cables (high voltage, large current), or bring them close to each other.
- (7) When installing the programmable controller in a control panel, fully consider its operability, maintainability, and environmental resistance. Securely mount all the MELSEC-Q series modules used on the base unit. For details on the mounting method, refer to the QCPU-A (A mode) User's Manual.

- (7) *Pour installer l'automate programmable dans un tableau de commande, prendre en compte tous les aspects d'opérabilité, de maintenabilité et de résistance à l'environnement. Monter fermement sur l'unité de base tous les modules de la série MELSEC-Q à utiliser. Pour le détail de la méthode de montage, voir le QCPU-A (A mode) User's Manual (Manuel de l'utilisateur QCPU-A (A mode)).*



## 4.1.2 Instructions for mounting the base unit

### (1) Mounting dimensions

Mounting dimensions of each base unit are as follows:

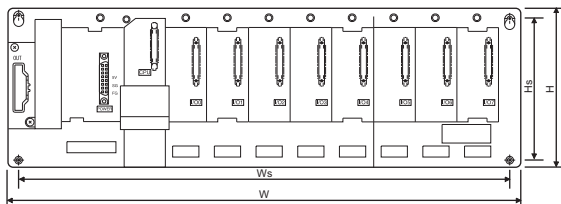

	QA1S33B	QA1S35B	QA1S38B	QA1S51B	QA1S65B	QA1S68B
W	255(10.04)	325(12.80)	430(16.93)	100(3.94)	315(12.40)	420(16.54)
Ws *1	235(9.25)	305(12.01)	410(16.14)	80(3.15)	295(11.61)	400(15.75)
H	130(5.12)					
Hs *1	110(4.33)					

Unit: mm (inches)

\*1 The tolerances of Ws and Hs are  $\pm 0.3$  mm, respectively.

### (2) Unit mounting position

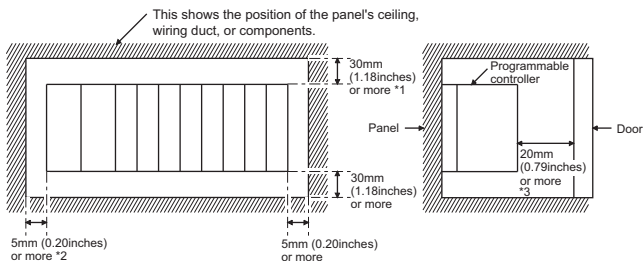

\*1 For wiring duct height of 50mm(1.97inches) or less. 40mm(1.57inches) or more for other cases.

\*2 20mm(0.79inches) or more when the extension cable is connected without removal of the adjacent module.

\*3 80mm(3.15inches) or more for the connector type.

(3) Unit mounting orientation

- (a) Since the programmable controller generates heat, it should be mounted on a well ventilated location in the orientation shown below.

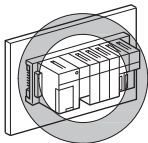

- (b) Do not mount it in either of the orientations shown below.

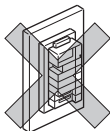

Vertical

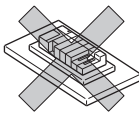

Flat

- (4) Mount base unit on a flat surface. If the mounting surface is not even, this may strain the printed circuit boards and cause malfunctions.
- (5) Avoid mounting base unit in proximity to vibration sources such as large magnetic contractors and no-fuse circuit breakers; mount these on a separate panel or at a distance.
- (6) In order to avoid the effects of radiated noise and heat, provide the clearances indicated below between the programmable controller and devices that generate noise or heat (contactors and relays).
- Required clearance in front of programmable controller: at least 100 mm (3.94 inches)
  - Required clearance on the right and left of programmable controller: at least 50 mm (1.97 inches)

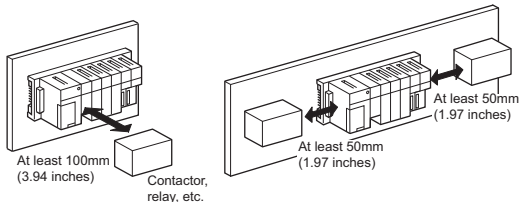

(7) If you want to mount base units on a DIN rail, please note the following points.

(a) Suitable DIN rail types are listed as follows(JIS C 2812):

TH35-7.5Fe

TH35-7.5Al

TH35-15Fe

\*JIS: Japanese Industrial Standard

(b) Spacing intervals for DIN rail mounting screws

When using a TH35-7.5Fe or TH35-7.5Al DIN rail, rail mounting screws should be placed at a pitch of 200 mm (7.87 inches) or less in order to ensure that the rail has sufficient strength.

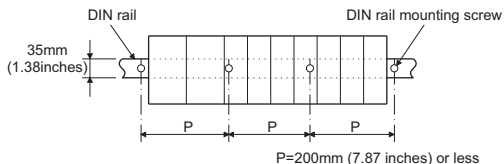

(8) When installing the base unit to DIN rail in an environment with large vibration, use a vibration-proofing bracket (A1S-PLT-D). Mounting the vibration-proofing bracket (A1S-PLT-D) enhances the resistance to vibration.

Depending on the environment to set up the base unit, it is also recommended to fix the base unit to the control panel directly.

### 4.1.3 Installation and removal of dustproof cover

When the QCPU-A is used, the dustproof cover supplied with the main base unit must be installed to the I/O module loaded on the right hand side of the QCPU-A to prevent the ingress of foreign matter into the I/O module.

Always install the dustproof cover. Without the dustproof cover, foreign matter will enter the I/O module, causing a failure.

How to install and remove the dustproof cover will be described below.

#### (1) Installation of dustproof cover

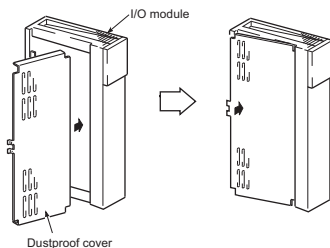

To insert the dustproof cover into the I/O module, insert it into the connector or terminal side slit first as shown above. Then push the opposite side of the dustproof cover into the I/O module to complete installation.

#### (2) Removal of dustproof cover

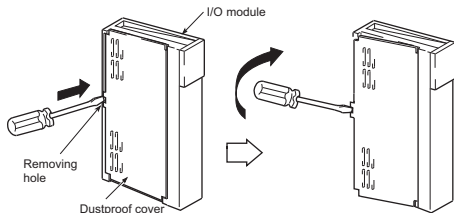

To remove the dustproof cover from the I/O module, insert the tip of a flat-blade screwdriver into the removing hole as shown above, move the screwdriver toward the back of the module, and take the catch of the dustproof cover off the removing hole.

## 4.1.4 Installation and removal of modules

This section explains how to install and remove a power supply, CPU, I/O, special function and other modules to and from the base unit.

### (1) Installation and removal of QCPU-A

#### (a) Installation of QCPU-A

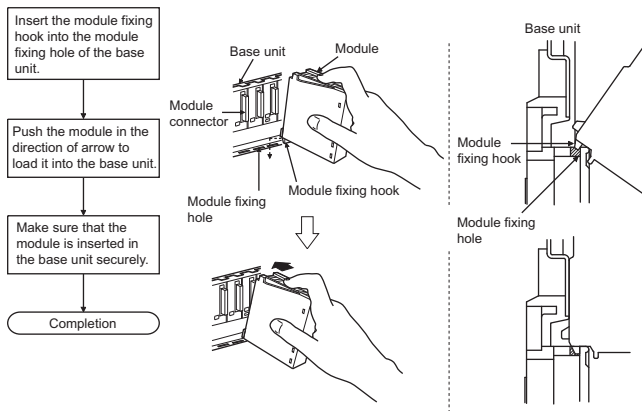

#### POINT

- (1) Insert the module fixing hook into the module fixing hole, making sure that the module is mounted vertically against the base unit. Failure to insert the hook or pressing the module to the base unit at an incorrect angle will damage the module and connector.
- (2) When using the programmable controller in a place where there is large vibration or impact, screw the CPU module to the base unit.  
QCPU-A module fixing screw: M3×12(user-prepared)

## (b) Removal of QCPU-A

Remove the module fixing screw, and using the bottom of the module as a support, pull the top of the module toward you.

While lifting the module, take the module fixing hook off the module fixing hole.

Completion

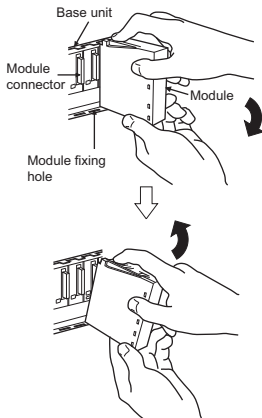

### POINT

When the module fixing screw is used, always remove the module by removing the module fixing screw and then taking the module fixing hook off the module fixing hole of the base unit. Forcibly removing the module will damage the module.

## (2) Installation and removal of module other than QCPU-A

### (a) Installation of module other than QCPU-A

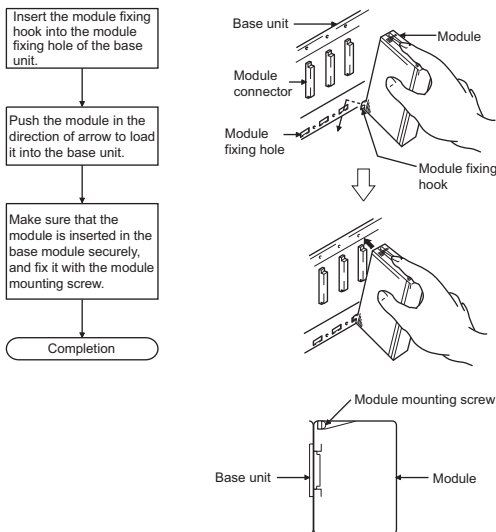

#### POINT

Always insert the module fixing hook of the module into the module fixing hole. Forcing the hook into the hole will damage the module connector and module.

## (b) Removal of module other than QCPU-A

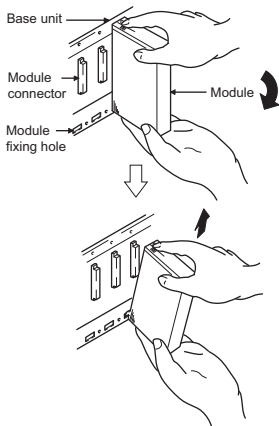
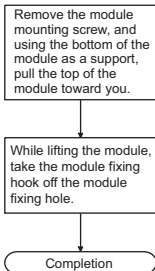

### POINT

Always remove the module by first removing the module fixing screw and then taking the module fixing hook off the module fixing hole of the base unit. Forcibly removing the module will damage the module.



## 4.1.5 Setting the extension number of the extension base unit

When using two or more extension base units, their extension numbers must be set with their extension number setting connectors. Extension 1 need not be set since the extension number is factory-set to 1. Make this setting in the following procedure.

- The extension number setting connector of the extension base unit is located under the IN side base cover. First, loosen the upper and lower screws in the IN side base cover and remove the base cover from the extension base unit.

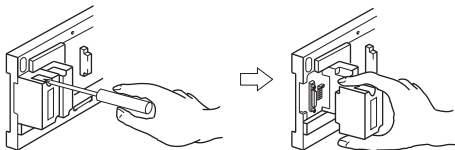

- Insert the connector pin in the required extension number location of the connector (PIN1) existing between the IN and OUT sides of the extension cable connector.

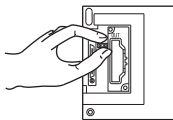

Setting of Number of Stages of Extension Base Units

	Setting of Number of Extension Stages						
	1st stage	2nd stage	3rd stage	4th stage	5th stage	6th stage	7th stage
Setting of No. of stages setting connector							

### POINT

Set the number setting connector to any of numbers 1 to 7 in ascending order. If two or more modules have the same number or any module has no setting, for example, false input and output will occur.

- (3) Install the base cover to the extension base unit and tighten the base cover screw.

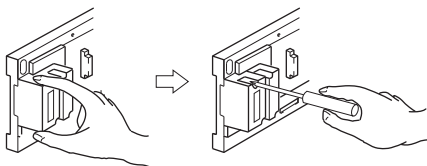

## 4.1.6 Connection and disconnection of extension cable

- (1) Instructions for handling an extension cable
- Do not stamp an extension cable.
  - An extension cable must be connected to the base unit when the base cover has been installed.  
(After you have set the extension number to the extension base unit, reinstall and screw the base cover.)
  - When running an extension cable, the minimum bending radius of the cable should be 55mm(2.17inches) or more.  
If it is less than 55mm(2.17inches), a malfunction may occur due to characteristic deterioration, open cable or the like.
  - When connecting or disconnecting an extension cable, do not hold the ferrite cores mounted at both ends of the cable.  
Hold the connector part of the cable for connection or disconnection.  
Holding the ferrite core may cause the cable to open within the connector.  
Also, if the ferrite core is shifted, the characteristic will change.  
When handling the cable, take care not to shift the ferrite core positions.

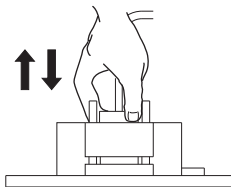

## (2) Connection of extension cable

### POINT

When connecting an extension base unit to the main base unit with an extension cable, always plug the OUT side connector of the main base unit and the IN side connector of the extension base unit with an extension cable. The system will not operate properly if the extension cable is connected in the form of IN → IN, OUT → OUT or OUT → IN.

When connecting two or more extension base units, plug the OUT side connector of the first extension base unit and the IN side connector of the second extension base unit with an extension cable.

- (a) To connect an extension cable to the main base unit, remove the portion under the OUT characters on the base cover with a tool such as a flat-blade screwdriver (5.5×75, 6×100). Insert the driver edge into the gap between the base cover and the section to be removed. Then raise up the driver edge so that the section will come off. Make sure not to insert the driver edge until it damages the connector inside the base cover. This also applies to a case where an extension cable is connected to the OUT side connector of the extension base unit.

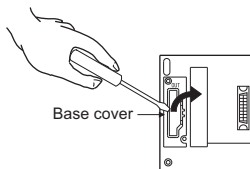

- (b) To connect the extension cable to the next extension base unit, remove the seal applied under the IN characters on the base cover.

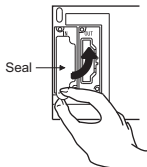

- (c) When plugging the extension cable to any base unit, hold the connector part of the extension cable.

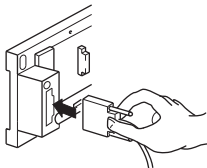

- (d) After fitting the extension cable, always tighten the extension cable connector fixing screws.  
(Tightening torque: 20N•cm)

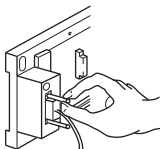

- (3) Disconnection of extension cable  
When unplugging the extension cable, hold and pull the connector part of the extension cable after making sure that the fixing screws have been removed completely.

## 4.2 Fail-Safe Circuit Concept

To prevent the programmable controller from providing false output or input, make up the circuit and program so that the programmable controller system will be started up in the following procedure.

- (1) Turn on the power to the programmable controller.
- (2) Turn on the external power supply used for the process control.
- (3) Turn on the START switch.
- (4) Turn on the power to the output devices by using a program.
- (5) Confirm that all external power supplies are turned on, and then, an I/O control program should be executed.

For example, if the processing external supply power of a DC output module is switched on and then the programmable controller is powered on, the DC output module may provide false output instantaneously. Though Mitsubishi programmable controllers are manufactured under strict quality control, they may cause failure or abnormal operations due to unspecific reasons. To prevent the abnormal operation of the whole system, machine breakdown, and accidents (e.g. emergency stop, protective and interlock circuits), fail-safe circuitry against failure of the programmable controller must be constructed outside the programmable controller.

The following page gives an example of system designing that conforms to the explanation mentioned above and an example of fail-safe measures when the programmable controller causes a failure.

## (1) System design circuit example

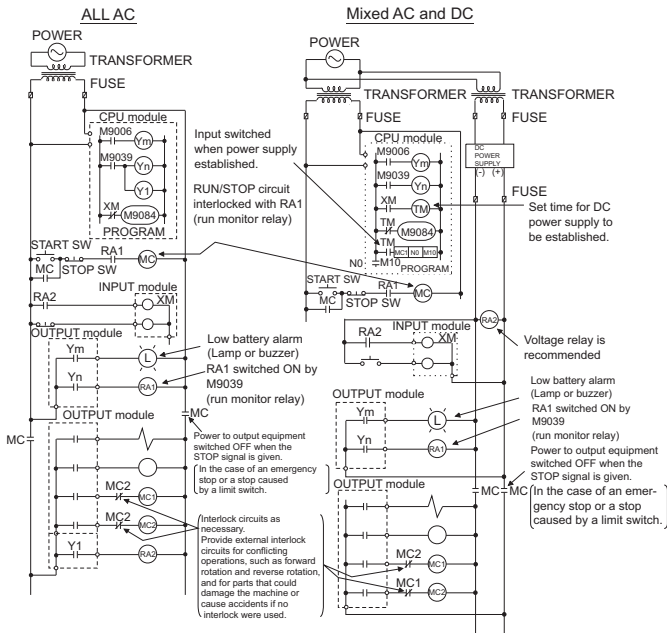

The power-ON procedure is as follows:

### For AC

- 1) Set the ON the power.
- 2) Switch CPU to RUN.
- 3) Turn on the start switch.
- 4) When the magnetic contactor (MC) comes in, the output equipment is powered and may be driven by the program.

### For AC/DC

- 1) Set the ON the power.
- 2) Switch CPU to RUN.
- 3) When DC power is established, RA2 goes ON.
- 4) Timer (TM) times out after the DC power reaches 100%. (The TM set value should be the period of time from when RA2 goes ON to the establishment of 100% DC voltage. Set this value to approximately 0.5 seconds.)
- 5) Turn on the start switch.
- 6) When the magnetic contactor (MC) comes in, the output equipment is powered and may be driven by the program. (If a voltage relay is used at RA2, no timer (TM) is required in the program.)

(2) Fail-safe measures to cover the possibility of programmable controller failure

Although a CPU module detects failures of programmable controller CPU and memory by using the self-diagnostics function, it may not detect those of I/O control area.

In such cases, all I/O points may turn on or off depending on the failure, or the control target may malfunction or the safety may not be ensured.

Mitsubishi programmable controllers are manufactured under strict quality control, however, build a fail-safe circuit outside the programmable controller in order that the programmable controller failure due to unspecified reasons will not result in the machinery breakdown or accidents.

The system example including fail safe circuit and fail safe circuit example are provided below.

<System example>

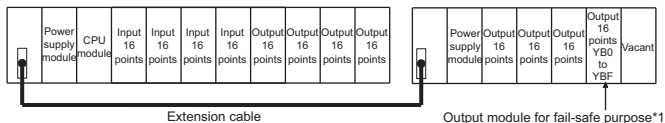

\*1 The output module for fail-safe purpose should be mounted on the last slot of the system. (YB0 to YBF in the above system.)



## <Fail-safe circuit example>

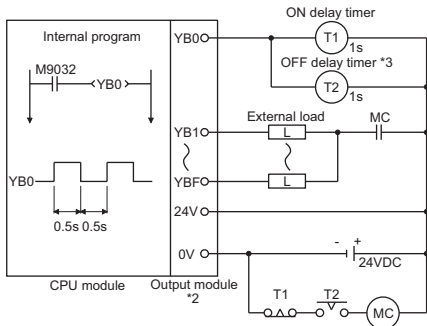

\*2 YB0 turns on and then off at alternatively 0.5 second intervals.

Use a contactless output module (transistor is used in the above example).

\*3 If an offdelay timer (especially miniature timer) is not available, construct the failsafe circuit using an ondelay timer shown on the next page.

### When constructing a failsafe circuit using ondelay timers only

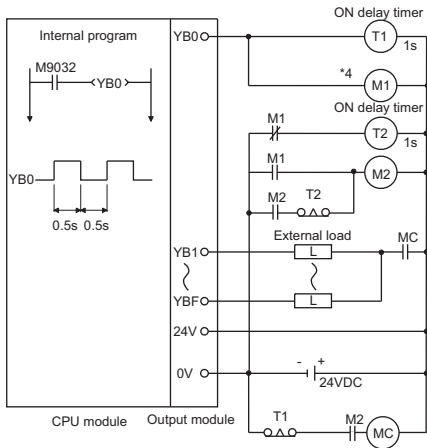

\*4 Use a solid state relay for the M1 relay.

## 4.3 Wiring

### 4.3.1 Power supply module specifications

This section gives the specifications of the power supply modules.

Power Supply Module Specifications

Item	Specifications		
	A1S61PN	A1S62PN	A1S63P
Base loading slot	Power supply module loading slot		
Rated input voltage	100 to 240VAC (85 to 264VAC)	+10% -15%	24VDC +30% -35% (15.6 to 31.2VDC)
Rated input frequency	50/60Hz ± 5%		—
Input voltage distortion factor	Within 5%		—
Max. input apparent power	105VA		41W
Inrush current	20A 8ms or lower *4		81A 1ms or lower
Rated output current	5VDC	5A	3A
	24VDC	—	0.6A
Overcurrent protection *1	5VDC	5.5A or higher	3.3A or higher
	24VDC	—	0.66A or higher
Overvoltage protection *2	5VDC	5.5 to 6.5V	
	24VDC	—	
Efficiency	65% or higher		
Allowable momentary power failure time *3	20ms or lower		10ms or lower (at 24VDC input)
Dielectric withstand voltage	Across inputs/LG and outputs/FG 2,830VAC rms/3 cycles (2000m(6562ft.))		500VAC across primary and 5VDC
Insulation resistance	Across inputs and outputs (LG and FG separated), across inputs and LG/FG, across outputs and FG/LG 10MΩ or higher by 500VDC insulation resistance tester		5MΩ or more by insulation resistance tester
Noise durability	Noise voltage 500 Vp-p, Noise width 1μs, Noise frequency 25 to 60 Hz (noise simulator condition) Noise voltage IEC61000-4-4, 2kV		Noise voltage 500 Vp-p, Noise width 1μs, Noise frequency 25 to 60 Hz (noise simulator condition)
Power indication	Power LED indication (light at the time of output of 5 VDC)		
Fuse	Built-in (Unchangeable by user)		
Terminal screw size <i>Taille des vis de borne</i>	M3.5×7 M3,5×7		
Applicable wire size <i>Taille du fil à utiliser</i>	0.75 to 2mm <sup>2</sup> 0,75 à 2mm <sup>2</sup>		
Applicable solderless terminal <i>Borne sans soudure à utiliser</i>	RAV 1.25 to 3.5, RAV 2 to 3.5 RAV 1,25 à 3,5, RAV 2 à 3,5		

## Power Supply Module Specifications

Applicable tightening torque <i>Couple de serrage à appliquer</i>	59 to 88N·cm <i>59 à 88N·cm</i>		
External dimension	130 × 55 × 93.6 (5.12 × 2.17 × 36.9)		mm (inches)
Weight	0.60 kg	0.60 kg	0.50 kg

POINT	
*1	<p><b>Overcurrent protection</b> The overcurrent protection device shuts off the 5VDC and/or 24VDC circuit(s) and stops the system if the current exceeding the specified value flows in the circuit(s).As this results in voltage drop, the power supply module LED turns off or is dimly lit.After that, power off the input power supply to eliminate the causes of overcurrent, e.g., insufficient current capacity and short circuit, and then power on the input power supply to start the system.When the current has reached the normal value, the initial start up of the system will be performed.</p>
*2	<p><b>Overvoltage protection</b> The overvoltage protection shuts off the 5VDC circuit and stops the system if the overvoltage of 5.5V is applied to the circuit.This results in the power supply module LED turning off.When restarting the system, power OFF and ON the input power supply, and the initial start up of the system will be performed.If the system is not booted and the LED remains off, this means that the power supply module has to be replaced. the LED remains off, this means that the power supply module has to be replaced.</p>
*3	<p><b>Allowable momentary power failure period</b> The programmable controller CPU allowable momentary power failure period varies with the power supply module used.In case of the A1S63P power supply module, the allowable momentary power failure period is defined as the time from when the primary side of the stabilized power supply for supplying 24VDC to the A1S63P is turned off until when the voltage (secondary side) has dropped from 24VDC to the specified value (15.6VDC) or less.</p>
*4	<p><b>Inrush current</b> If the power supply module is re-powered on right after powered off (within 5s), the inrush current exceeding the specified value (2ms or less) may be generated. Therefore, make sure to re-power on the module 5seconds after power off.When selecting a fuse or breaker for external circuit, consider the above point as well as meltdown and detection characteristics.</p>

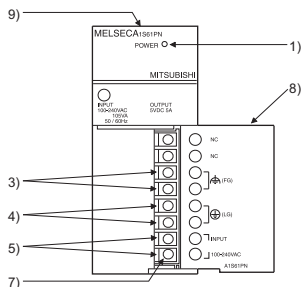
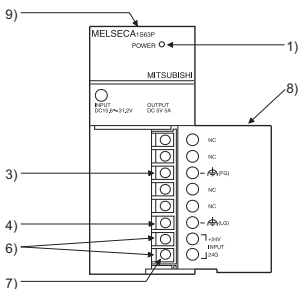
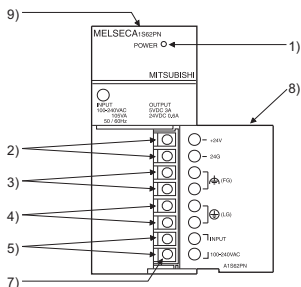
**(1) A1S61PN****(2) A1S62PN****(3) A1S63P**

No.	Name	Description
1)	POWER LED	The indicator LED for the 5 VDC power.
2)	24 V and 24 G terminals	Used to supply 24VDC to inside the output module (using external wiring).
3)	FG terminal	The grounding terminal connected to the shield pattern of the printed circuit board.
4)	LG terminal	Grounding for the power supply filter. The potential of A1S61PN or A1S62PN terminal is 1/2 of the input voltage.
5)	Power supply input terminals	Used to connect 100VAC to 200VAC power supply.
6)	Power supply input terminals	Used to connect a 24VDC power supply.
7)	Terminal screw	M3.5 × 7
8)	Terminal cover	The protective cover of the terminal block.
9)	Module fixing screw	Used to fix the module to the base unit. (M4 screw, tightening torque : 59 to 88 N·cm)

**POINT**

- (1) Do not use the terminal which is printed NC on the terminal block.
- (2) Be sure to ground the terminal LG and FG to the protective ground conductor.

## 4.3.2 The precautions on the wiring

This section gives instructions for wiring the power supply.

### (1) Wiring of power supply

- (a) When voltage fluctuations are larger than the specified value, connect a constant-voltage transformer.

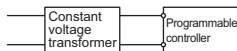

- (b) Use a power supply which generates minimal noise between wires and between the programmable controller and ground. If excessive noise is generated, connect an insulating transformer.

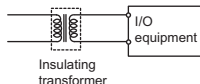
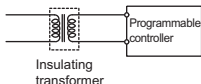

- (c) When a power transformer or insulating transformer is employed to reduce the voltage from 200 VAC to 100 VAC, use one with a capacity greater than those indicated in the following table.

Power Supply Module	Transformer Capacity
A1S61PN	110VA × n
A1S62PN	110VA × n

n: Stands for the number of power supply modules.

- (d) Separate the programmable controller's power supply line from the lines for I/O devices and power devices as shown below.  
When there is much noise, connect an insulation transformer.
- (e) Taking rated current or inrush current into consideration when wiring the power supply, be sure to connect a breaker or an external fuse that have proper blown and detection.

When using a single programmable controller, a 10A breaker or an external fuse are recommended for wiring protection.

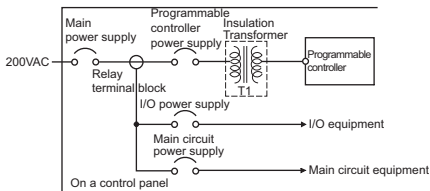

- (f) Note on using the 24 VDC output of the A1S62PN power supply module.  
If the 24 VDC output capacity is insufficient for one power supply module, supply 24 VDC from the external 24 VDC power supply as shown below:

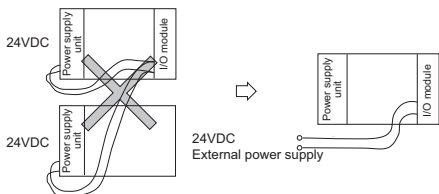

- (g) 100 VAC, 200 VAC and 24 VDC wires should be twisted as dense as possible. Connect the modules with the shortest distance.  
Also, to reduce the voltage drop to the minimum, use the thickest wires possible (maximum  $2\text{mm}^2$ ).
- (h) Do not bind 100VAC and 24VDC wires together with main circuit (high tension and large current) wires or I/O signal line (including common line) nor place them near each other. Provide 100mm (3.94 inches) clearance between the wires if possible.

- (i) As a countermeasure to power surge due to lightening, connect a surge absorber for lightening as shown below.

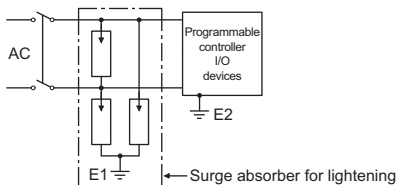

POINT
-------

- |  |
|--|
| POINT  |
| <p>(1) Separate the ground of the surge absorber for lightening (E1) from that of the programmable controller (E2).</p> <p>(2) Select a surge absorber for lightening whose power supply voltage does not exceed the maximum allowable circuit voltage even at the time of maximum power supply voltage elevation.</p> |

(2) Wiring to I/O device

- (a) The solderless terminal with insulation sleeve is inapplicable to a terminal block.  
It is advisable to cover the wire connection part of a terminal with a mark tube or insulation tube.
- (b) Install wiring to a terminal block using the cable of core diameter 0.3 to 0.75mm<sup>2</sup>, and outside diameter 2.8mm or less.
- (c) Run the I/O line and output line away from each other.
- (d) When the main circuit line and power line cannot be separated, use a shielding cable and ground it on the programmable controller side.  
However, ground it on the opposite side in some cases.

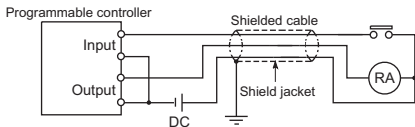

- (e) When cables are run through pipes, securely ground the pipes.
- (f) Run the 24VDC input line away from the 100VAC and 200 VAC lines.

- (g) The cabling of 200m (656.2ft.) or longer distance may produce leakage current depending on the capacity between lines and result in an accident.
- (h) As a countermeasure against the power surge due to lightning, separate the AC wiring and DC wiring and connect a surge absorber for lightning as shown in (i) of item (1). Failure to do so increases the risk of I/O device failure due to lightning.

(3) Grounding

- (a) Carry out the independent grounding if possible. (Grounding resistance  $100\Omega$  or less.)
- (b) If the independent grounding is impossible, carry out the shared grounding (2) as shown below.

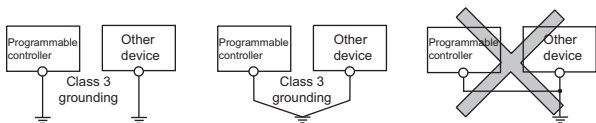

(1) Independent grounding.....Best (2) Shared grounding.....Good (3) Common grounding.....Not allowed

- (c) Use thick cables up to  $2\text{mm}^2$ . Bring the grounding point close to the programmable controller as much as possible so that the ground cable can be shortened.
- (d) If a malfunction occurs due to earthing, separate either LG or FG of the base module, the device combination, or all the connection from the earthing.



### 4.3.3 Connecting to the power supply module

The following diagram shows the wiring example of power lines, grounding lines, etc. to the main and extension bases.

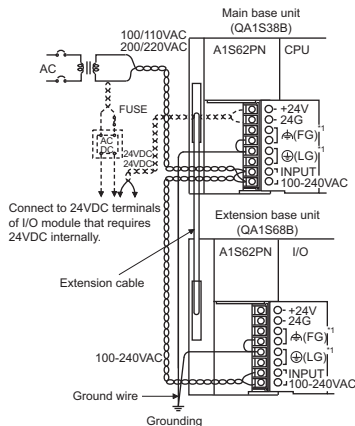

- \*1 Ground the LG and FG terminals by using a ground wire as thick and short as possible (2mm in diameter).

#### POINT

- Use the thickest possible (max. 2 mm<sup>2</sup> (14 AWG)) wires for the 100/200 VAC and 24 VDC power cables. Be sure to twist these wires starting at the connection terminals. For wiring a terminal block, be sure to use a solderless terminal. To prevent short-circuit due to loosening screws, use the solderless terminals with insulation sleeves of 0.8 mm (0.03 inches) or less thick. The number of the solderless terminals to be connected for one terminal block are limited to 2.

Solderless terminals with insulation sleeves Terminal block

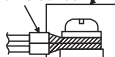

- Be sure to ground the LG and FG terminals. Failure to do so may cause the programmable controller to be susceptible to noise. Note that LG terminals include the potential as half as that of input voltage; you might get an electric shock when you touch them.
- A1S61PN and A1S62PN do not need to be switched as they are 100 to 240VAC wide-range.

## 4.4 Precautions when Connecting the Uninterruptible Power Supply (UPS)

Connect the QCPU-A system to the uninterruptible power supply (UPS), while paying attention to the followings.

When connecting an uninterruptible power supply (UPS) to the programmable controller system, use an online UPS or line-interactive UPS with a voltage distortion rate of 5% or less.

When connecting a standby UPS, use a Mitsubishi FREQUPS FW-F series UPS (hereinafter FW-F series UPS)\*<sup>1</sup>. (Example: FW-F10-0.3K/0.5K)

Do not use any standby UPS other than the FW-F series UPS.

- \*1 The FW-F series UPS whose serial number starts with the letter "P" or later, or ends with the letters "HE" is applicable.

SERIAL : 00000000  
          └──────────┬──────────┘ Starts with "P" or later

SERIAL : B0000000    HE  
                          └──┘ Ends with "HE"

## 4.5 Part Names and Settings of the CPU Module

### 4.5.1 Part names and settings

This section explains the names and settings of the CPU module.

Front face

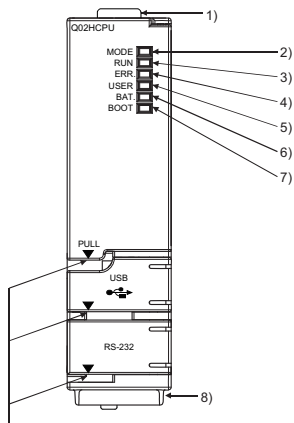

When opening the cover, put your finger here.

With front cover open

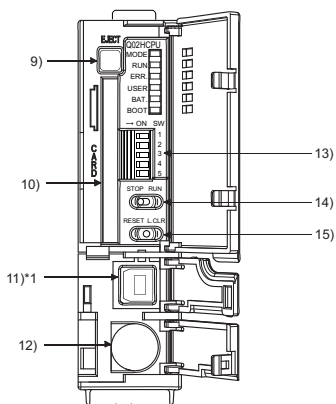

\*1 Not provided for Q02CPU-A.

Side face

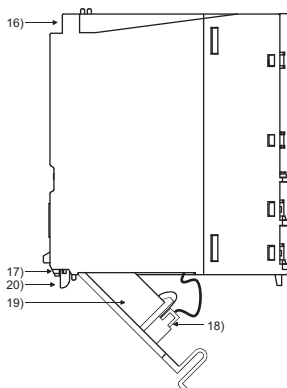

No.	Name	Applications
1)	Module fixing hook	Hook used to fix the module to the base unit. (Single-motion installation)
2)	Mode LED	Indicates the mode of the CPU. Lit (orange) : A mode Lit (green) : Q mode
3)	RUN LED	Indicates the operating status of the CPU. On : During operation in "RUN" or "STEP RUN" mode. Off : During a stop in "STOP", "PAUSE" or "STEP RUN" mode or detection of error whose occurrence stops operation.
4)	ERR. LED	On : Detection of self-diagnostics error which will not stop operation, except battery error. (When operation continued at error detection is set in the parameter) Off : Normal Flicker : Detection of error whose occurrence stops operation.
5)	USER LED	On : Annunciator ON Off : Normal Flicker : Execution of latch clear
6)	BAT. LED	On : Occurrence of battery error due to reduction in battery voltages of CPU and memory card. Off : Normal
7)	BOOT LED	On : Execution of boot operation Off : Non-execution of boot operation
8)	Serial number	Shows the serial number printed on the rating plate.
9)	Memory card EJECT button	Used to eject the memory card from the CPU.
10)	Memory card loading connector	Connector used to load the memory card to the CPU.
11)	USB connector *2	Unusable (Usable for Q mode only)
12)	RS-232 connector *2	Connector for connection with a peripheral device. Can be connected by RS-232C connection cable (QC30R2).

\*2 When normally connecting a cable to the USB connector or RS-232 connector, clamp the cable to prevent it from coming off due to the dangling, moving or carelessly pulling of the cable.

No.	Name	Applications
13)	DIP switches 	Used to set the items for operation of the CPU. SW1: Must not be used. Normally off. (Shipped in off position) SW2: Must not be used. Normally off. (Shipped in off position) SW3: RAM/boot operation designation. (Shipped in off position) On : Boot operation Off : RAM operation SW4: Must not be used. Normally off. (Shipped in off position) SW5: Must not be used. Normally off. (Shipped in off position)
14)	RUN/STOP switch	RUN : Executes sequence program operation. STOP : Stops sequence program operation.
15)	RESET/L.CLR switch	RESET : Used to perform hardware reset, operation fault rest, operation initialization, etc. If this switch is left in the RESET position, the whole system will be reset and the system will not operate properly. After performing reset, always return this switch to the neutral position. L.CLR : Used to turn "OFF" or "zero" all data in the parameter-set latch area. Used to clear the sampling trace and status latch registration.
16)	Module fixing screw hole	Hole for the screw used to fix to the base unit. (M3 × 12 screw)
17)	Module fixing hook	Hook used to fix to the base unit.
18)	Battery connector pin	For connection of battery lead wires. (When shipped from the factory, the lead wires are disconnected from the connector to prevent the battery from consuming.)
19)	Battery	Backup battery for use of built-in RAM and power failure compensation function.
20)	Module loading lever	Used to load the module to the base unit.

## 4.5.2 Switch operation after program write

- (1) When writing a program during STOP of CPU  
Write a program during STOP of the CPU in the following procedure.
  - 1) RUN/STOP switch: STOP  
RUN LED: Off.....CPU STOP status → Program write
  - 2) RUN/STOP switch: STOP → RUN  
RUN LED: On.....CPU RUN status
- (2) When you wrote a program during RUN  
When you wrote a program during RUN of the CPU, do not operate the switch.

## 4.5.3 Latch clear operation

To perform latch clear, operate the RESET/L.CLR switch in the following procedure.

- 1) RESET/L.CLR switch: Move the switch to L.CLR several times until the USER LED flickers.  
(Do not move it to RESET.)  
USER LED: Flicker.....Ready for latch clear.
- 2) RESET/L.CLR switch: Move the switch to L.CLR once more.  
USER LED: Off.....Latch clear complete.

POINT
-------

Latch clear can be set to be valid or invalid device-by-device by making device setting in the parameter. For the operation method, refer to the operating manual of GPP function.
---

## 4.5.4 Installation and removal of memory card during power-on

Do not install or remove the memory card while power is on.

POINT
-------

If you installed or removed the memory card while power was on, the data within the memory card may be corrupted.
---



## 5. SPECIFICATIONS AND CONNECTIONS OF I/O MODULES

### 5.1 Input modules

#### 5.1.1 Input module specifications

Model	Type	No. of Points	Rated Input Voltage	Input Current	Operating Voltage					
					ON voltage	OFF voltage				
A1SX10	AC input	16	100 to 120VAC	6mA	80VAC or higher	30VAC or lower				
A1SX10EU				7mA						
A1SX20			200 to 240VAC	9mA						
A1SX20EU				11mA						
A1SX30	DC/AC input		12/24VDC	4.2/8.6mA	7VDC/AC or higher	2.7VDC/AC or lower				
			12/24VAC							
A1SX40	DC input (sink type)		12/24VDC	3/7mA	8VDC or higher	4VDC or lower				
A1SX40-S1			24VDC	7mA	14VDC or higher	6.5VDC or lower				
A1SX40-S2										
A1SX41			12/24VDC	3/7mA	8VDC or higher	4VDC or lower				
A1SX41-S1							24VDC	7mA	17VDC or higher	3.5VDC or lower
A1SX41-S2			14VDC or higher	6.5VDC or lower						
A1SX42					12/24VDC	2/5mA	8VDC or higher	4VDC or lower		
A1SX42-S1			24VDC	5mA					18.5VDC or higher	3VDC or lower
A1SX42-S2									17.5VDC or higher	7VDC or lower
				64						



	Maximum Simultaneous Input Points (Percentage Simultaneously ON)	Max. Response Time		Field Wiring	Points/ Common	Internal Current Consumption (5VDC)	NO. of Occupied Points
		OFF to ON	ON to OFF				
	100%(110VAC) 60%(132VAC)	20ms or lower	35ms or lower	Terminal	16	0.05A	16
	100%(110VAC)						
	60%(220VAC)	30ms or lower	55ms or lower				
	75%(26.4VDC)	20ms or lower	20ms or lower				
		25ms or lower	20ms or lower				
	100%(26.4VDC)	10ms or lower	10ms or lower				
		0.1ms or lower	0.2ms or lower				
	60%(26.4VDC)	10ms or lower	10ms or lower	40-pin connector	32	0.08A	32
		0.3ms or lower	0.3ms or lower			0.12A	
		10ms or lower	10ms or lower			0.08A	
	50%(24VDC)	0.3ms or lower	0.3ms or lower	40-pin connector ×2		0.09A	64
						0.16A	
						10ms or lower	

Model	Type	No. of Points	Rated Input Voltage	Input Current	Operating Voltage		
					ON voltage	OFF voltage	
A1SX71	DC input (sink/source type)	32	5/12/24VDC	1.2/3.3/ 7mA	3.5VDC or higher	1VDC or lower	
A1SX80		16	12/24VDC	3/7mA	8VDC or higher	4VDC or lower	
A1SX80-S1			24VDC	7mA	17VDC or higher	5VDC or lower	
A1SX80-S2			24VDC		13VDC or higher	6VDC or lower	
A1SX81			32	12/24VDC	3/7mA	8VDC or higher	4VDC or lower
A1SX81-S2		24VDC		7mA	13VDC or higher	6VDC or lower	
A1SX82-S1		64	24VDC	5mA	18.5VDC or higher	3VDC or lower	
A1S42X		DC input (dynamic)	*2 16/32 48/64	12/24VDC	4/9mA	8VDC or higher	4VDC or lower

	Maximum Simultaneous Input Points (Percentage Simultaneously ON)	Max. Response Time		Field Wiring	Points/ Common	Internal Current Consumption (5VDC)	NO. of Occupied Points
		OFF to ON	ON to OFF				
	65%(24VDC)	1.5ms or lower	3ms or lower	40-pin connector	32	0.075A	32
	100%(26.4VDC)	10ms or lower	10ms or lower	Terminal	16	0.05A	16
	85%(26.4VDC)	0.4ms or lower	0.5ms or lower				
	100%(26.4VDC)	10ms or lower	10ms or lower				
	60%(26.4VDC)	10ms or lower	10ms or lower	37-pin D-sub connector	32	0.08A	32
	50%(26.4VDC)	0.3ms or lower	0.3ms or lower	40-pin connector ×2	32	0.16A	64
	100%(26.4VDC)	0.4ms or lower <sup>*1</sup>	0.4ms or lower <sup>*1</sup>	24-pin connector	-	0.08A	16/32/48/64

For all modules, the insulation system is photocoupler insulation and the input indications are LED indications.

\*1.....The dynamic scan cycle is 13.3ms.

\*2.....Set using the DIP switch on the module front.

## 5.1.2 Input module connections

### Input module connections

(1)	Model	Rated Input Voltage	(2)	Model	Rated Input Voltage
	A1SX10	100 to 120 VAC		A1SX30	12/24 VAC/DC
	A1SX10EU				
	A1SX20	200 to 240 VAC			
	A1SX20EU	VAC			
<p>9 and 18 are reconnected internally.</p>			<p>9 and 18 are reconnected internally.</p>		
(3)	Model	Rated Input Voltage	(4)	Model	Rated Input Voltage
	A1SX40	12/24 VDC		A1SX80	12/24 VDC
	A1SX40-S1			A1SX80-S1	
	A1SX40-S2	24 VDC		A1SX80-S2	24 VDC
<p>9 and 18 are reconnected internally.</p>			<p>9 and 18 are reconnected internally.</p>		
English	French	English	French		
100 to 120 VAC	de 100 à 120 V ca	12/24 VAC/DC	12/24 V ca/cc		
200 to 240 VAC	de 200 à 240 V ca	24 VDC	24 V cc		
9 and 18 are connected internally	9 et 18 sont connectés à l'intérieur	Model	Modèle		
Rated Load Voltage	Tension nominale de charge	Vacant	Libre		

(5)	Model	Rated Input Voltage
	A1SX41	12/24 VDC
	A1SX41-S1(S2)	24 VDC
	A1SX42	12/24 VDC
	A1SX42-S1(S2)	24 VDC
A1SX82-S1*3		

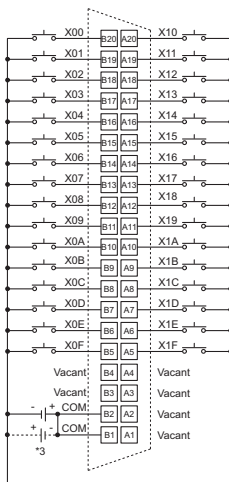

- \*1 The figure above indicates **[F]** (the first half 32 points).  
The connections for **[L]** (the latter half 32 points) are the same as for **[F]** (regard X00 to X1F as X20 to X3F.)  
**[B1]** and **[B2]** are connected internally.
- \*2 The A and B pin number rows shown above are transposed with respect to the diagram of the A and B rows which is printed on the module. Remember that the A row pin numbers correspond to the B row of the module.
- \*3 A1SX82-S1 can use both positive common and negative common.
- \*1 La figure ci-dessus représente **[F]** (première moitié de 32 points).  
Les connexions pour **[L]** (deuxième moitié de 32 points) sont comme pour **[F]** (considérer X00 à X1F comme état X20 à X3F.)  
**[B1]** et **[B2]** sont connectés à l'intérieur.
- \*2 Les rangées de broches A et B ci-dessus correspondent aux rangées de broches marquées A et B sur le schéma imprimé sur le module. Noter que les numéros de broche de rangée A correspondent à la rangée B sur le module.
- \*3 A1SX82-S1 peut s'utiliser avec commun en positif ou commun en négatif.

English	French	English	French
Model	Modèle	Rated Load Voltage	Tension nominale d'entrée
Vacant	Libre	VDC	V cc

(6)	Model	Rated Input Voltage
	A1SX71	5/12/24 VDC

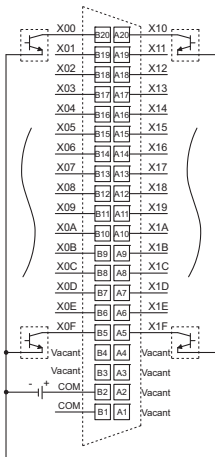

\*1 The figure above shows the connections for the open collector (sink) type.

**[B1]** and **[B2]** are connected internally.

\*1 La figure ci-dessus représente les connexions pour le type collecteur ouvert (dissipateur).

**[B1]** et **[B2]** sont connectés à l'intérieur.

- TTL, LS-TTL, CMOS buffer (sink) connection  
TTL, LS-TTL, connexion tampon CMOS (dissipateur)

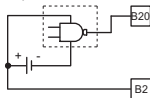

- Sensor (source) connection  
Connexion capteur (source)

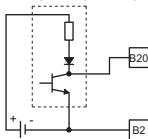

\*2 The A and B pin number rows shown above are transposed with respect to the diagram of the A and B rows which is printed on the module. Remember that the A row pin numbers correspond to the B row of the module.

\*2 Les rangées de broches A et B ci-dessus correspondent aux rangées de broches marquées A et B sur le schéma imprimé sur le module. Noter que les numéros de broche de rangée A correspondent à la rangée B sur le module.

English	French	English	French
Model	Modèle	Rated Load Voltage	Tension nominale d'entrée
Vacant	Libre	VDC	V cc

	Model	Rated Input Voltage
(7)	A1SX81	12/24 VDC
	A1SX81-S2	24 VDC

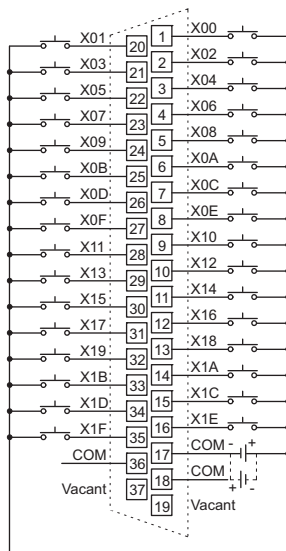

- [17], and [18] and [36] are connected internally.  
[17], [18] et [36] sont connectés à l'intérieur.

English	French	English	French
Model	Modèle	Rated Load Voltage	Tension nominale d'entrée
Vacant	Libre	VDC	V <sub>cc</sub>

(8)	Model	Rated Input Voltage
	A1S42X	12/24 VDC

### Pin Arrangement

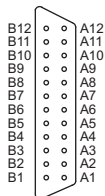

Seen from front face of the module

Pin No.	Signal Name	Pin No.	Signal Name
B12	XD0	A12	XD1
B11	XD2	A11	XD3
B10	XD4	A10	XD5
B9	XD6	A9	XD7
B8	XSCN0	A8	XSCN 1
B7	XSCN 2	A7	XSCN 3
B6	XSCN 4	A6	XSCN 5
B5	XSCN 6	A5	XSCN 7
B4	Vacant	A4	Vacant
B3	12/24 VDC	A3	12/24 VDC
B2	0V	A2	0V
B1	FG	A1	FG

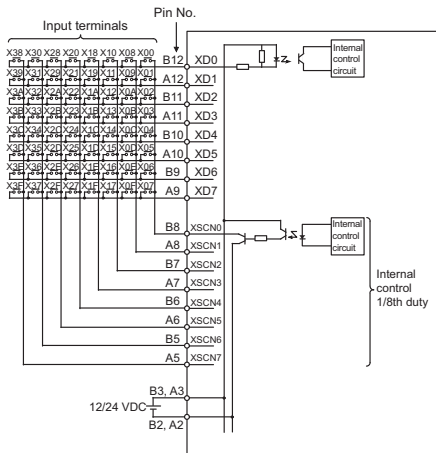

\* If there will be cases where two or more switches are pressed simultaneously, install a diode at each switch (see right).



English	French	English	French
Input terminals	Bornes d'entrée	If there will be cases where two or more switches are pressed simultaneously, install a diode at each switch (see right).	Dans le cas où deux contacteurs ou plus sont actionnés simultanément, installer une diode pour chaque contacteur (voir ci-contre à droite).
Model	Modèle	Internal control circuit	Circuit de commande interne
Pin No.	Broche N°	Internal control 1/8th duty	Commande interne facteur d'utilisation 1/8ème
Signal Name	Nom de signal	Rated Load Voltage	Tension nominale d'entrée
Vacant	Libre	Pin Arrangement	Attribution des broches
VDC	V cc	Seen from front face of the module	Vu depuis le devant du module





## 5.2 Output modules

### 5.2.1 Output module specifications

Model	Type	No. of Points	Rated Load Voltage	Max. Load Current			Max. Output Response Time		
				Point	Common	Module	OFF to ON	ON to OFF	
A1SY10	Relay Output	16	100V to 240VAC 24VDC	2A	8A	-	10ms or lower	12ms or lower	
A1SY 10EU			100V to 120VAC 24VDC			-			
A1SY 14EU		12	100V to 240VAC 24VDC			-			
A1SY 18A						-			8A
A1SY 18AEU						-			-
A1SY22	Triac Output	16	100V to 240VAC	0.6A	2.4A	-	1ms or lower	1ms + 0.5 cycles or less	
A1SY 28A		8		1A	-	8A(AC1 32V, 46°C), 8A(AC2 64V, 40°C) 4A(AC1 32V, 55°C), 2A(AC2 64V, 55°C)			
A1SY 28EU									0.6A

For all modules, the insulation system is photocoupler insulation and the output indications are LED indications.

\*1.....The dynamic scan cycle is 13.3ms (FAST mode) or 106.7ms (SLOW mode).  
(Set using the DIP switch on the module rear.)

\*2.....Set using the DIP switch on the module front.

Field Wiring	Points/ Common	Surge Suppression	Fuse Rating	Error display	External Power Supply (TYP DC24V)		Internal Current Consumption	No. of Occupied Points
					Current			
	8	None	None	None	0.090A	0.12A	16	
	4				0.1A	0.12A		
	-				0.075A	0.24A		
					0.075A	0.24A		
Terminal	8	CR absorber	5A	LED*5	0.002A*3	0.27A		
	-	CR absorber varistor	None	None	-	0.13A		
	4	CR absorber				0.27A		

\*3.....Value at TYP 200VAC.

\*4.....Value at TYP 12VDC.

\*5....."ERR." LED turns on when fuse is blown or external supply power is off.

\*6.....0.08A is shown on the rating plate of the module.

\*7.....0.15A is shown on the rating plate of the module.

Model	Type	No. of Points	Rated Load Voltage	Max. Load Current			Max. Output Response Time	
				Point	Common	Module	OFF to ON	ON to OFF
A1SY40	Transistor Output (sink type)	16	12/24V DC	0.1A	0.8A	-	2ms or lower	2ms or lower
A1SY 40P						-	1ms or lower	1ms or lower
A1SY41		32			2A	-	2ms or lower	2ms or lower
A1SY 41P						-	1ms or lower	1ms or lower
A1SY42		64			1.6A	-	2ms or lower	2ms or lower
A1SY 42P					2A	-	1ms or lower	1ms or lower
A1SY50		16			0.5A	2A	-	2ms or lower
A1SY60	24VDC		2A (25°C) 1.8A (45°C) 1.6A (55°C)	4A (25°C) 3.6A (45°C) 3.2A (55°C)	-			
A1SY 60E	Transistor Output (source type)	5/12 /24VDC	2A	4A	-	3ms or lower	10ms or lower	
A1SY 68A	Transistor Output (sink/source type)	5/12 24/ 48VDC	2A	-	-			
A1SY71	Transistor Output (for TTL/ CMOS) sink type	32	5/ 12VDC	0.016A	0.256A	-	1ms or lower	1ms or lower

For all modules, the insulation system is photocoupler insulation and the output indications are LED indications.

\*1.....The dynamic scan cycle is 13.3ms (FAST mode) or 106.7ms (SLOW mode).

(Set using the DIP switch on the module rear.)

\*2.....Set using the DIP switch on the module front.

	Field Wiring	Points/ Common	Surge Suppression	Fuse Rating	Error display	External Power Supply (TYP DC24V)	Internal Current Consumption	No. of Occupied Points
						Current		
	Terminal	8	Zener diode	1.6A	LED*5	0.008A	0.27A	16
				None	None	0.011A	0.079A*6	
	40-pin connector	32		3.2A	LED*5	0.008A	0.5A	32
				None	None	0.012A	0.141A*7	
	40-pin connector ×2			3.2A	LED*5	0.008A	0.93A	64
				None	None	0.014A	0.17A	
	Terminal	8		3.2A	LED*5	0.06A	0.12A	16
				5A		0.015A	0.12A	
				7A		0.01A	0.2A	
				None		None	-	
		-						
40-pin connector	32	None	1.6A	LED*5	0.15A *4	0.4A	32	

\*3.....Value at TYP 200VAC.

\*4.....Value at TYP 12VDC.

\*5....."ERR." LED turns on when fuse is blown or external supply power is off.

\*6.....0.08A is shown on the rating plate of the module.

\*7.....0.15A is shown on the rating plate of the module.

Model	Type	No. of Points	Rated Load Voltage	Max. Load Current			Max. Output Response Time	
				Point	Common	Module	OFF to ON	ON to OFF
A1SY80	Transistor Output (source type)	16	12/24V DC	0.8A	3.2A	-	2ms or lower	2ms or lower
A1SY81				0.1A	2A	-		
A1SY81EP		32		0.1A (25°C), 0.05A (55°C)	2A (25°C), 1.6A (55°C)	-	0.5ms or lower	1.5ms or lower
A1SY82		64		0.1A	1.6A	-	2ms or lower	2ms or lower
A1S42Y	Transistor Output (dynamic)	16/32 48/64 *2		0.1A (40°C) 0.05A (55°C)	-	-	2ms or lower *1	2ms or lower *1

For all modules, the insulation system is photocoupler insulation and the output indications are LED indications.

\*1.....The dynamic scan cycle is 13.3ms (FAST mode) or 106.7ms (SLOW mode).

(Set using the DIP switch on the module rear.)

\*2.....Set using the DIP switch on the module front.

	Field Wiring	Points/ Common	Surge Suppression	Fuse Rating	Error display	External Power Supply (TYP DC24V)	Internal Current Consumption	No. of Occupied Points
						Current		
	Terminal	8	Zener diode	5A	LED	0.020A	0.12A	16
	37-pin D-sub connector	32		3.2A		0.008A	0.5A	32
Clamp diode			None	None	0.080A	0.5A		
	40-pin connector ×2	32	Zener diode	3.2A	LED*5	0.008A	0.93A	64
	24-pin connector	-	None	1.6A	LED	0.055A	0.18A	16/32 48/64

\*3.....Value at TYP 200VAC.

\*4.....Value at TYP 12VDC.

\*5....."ERR." LED turns on when fuse is blown or external supply power is off.

\*6.....0.08A is shown on the rating plate of the module.

\*7.....0.15A is shown on the rating plate of the module.

## 5.2.2 Output module connections

### Connexions du module de sortie

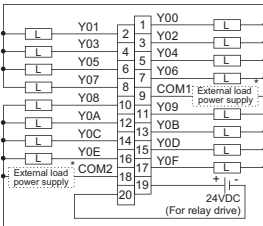
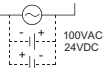
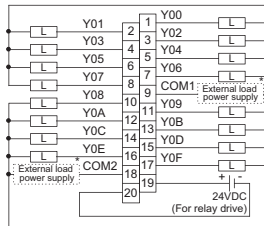
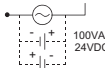
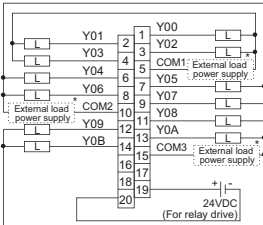
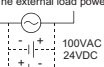
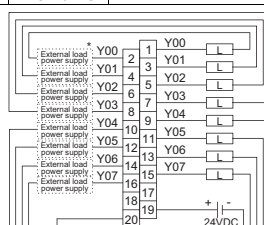
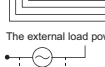
<p>(1)</p> <table border="1"> <thead> <tr> <th>Model</th> <th>Rated Load Voltage</th> </tr> </thead> <tbody> <tr> <td>A1SY10</td> <td>24VDC, 100 to 240VAC</td> </tr> </tbody> </table>  <p>* The external load power supply section is as shown below.</p> 	Model	Rated Load Voltage	A1SY10	24VDC, 100 to 240VAC	<p>(2)</p> <table border="1"> <thead> <tr> <th>Model</th> <th>Rated Load Voltage</th> </tr> </thead> <tbody> <tr> <td>A1SY10EU</td> <td>24VDC, 100 to 120VAC</td> </tr> </tbody> </table>  <p>* The external load power supply section is as shown below.</p> 	Model	Rated Load Voltage	A1SY10EU	24VDC, 100 to 120VAC
Model	Rated Load Voltage								
A1SY10	24VDC, 100 to 240VAC								
Model	Rated Load Voltage								
A1SY10EU	24VDC, 100 to 120VAC								
<p>(3)</p> <table border="1"> <thead> <tr> <th>Model</th> <th>Rated Load Voltage</th> </tr> </thead> <tbody> <tr> <td>A1SY14EU</td> <td>24VDC, 100 to 240VAC</td> </tr> </tbody> </table>  <p>* The external load power supply section is as shown below.</p> 	Model	Rated Load Voltage	A1SY14EU	24VDC, 100 to 240VAC	<p>(4)</p> <table border="1"> <thead> <tr> <th>Model</th> <th>Rated Load Voltage</th> </tr> </thead> <tbody> <tr> <td>A1SY18A A1SY18AEU</td> <td>24VDC, 100 to 240VAC</td> </tr> </tbody> </table>  <p>* The external load power supply section is as shown below.</p> 	Model	Rated Load Voltage	A1SY18A A1SY18AEU	24VDC, 100 to 240VAC
Model	Rated Load Voltage								
A1SY14EU	24VDC, 100 to 240VAC								
Model	Rated Load Voltage								
A1SY18A A1SY18AEU	24VDC, 100 to 240VAC								
English	French	English	French						
100 to 240 VAC	de 100 à 240 V ca	For relay drive	Pour attaque du relais						
24 VDC	24 V cc	External load power supply	Alimentation charge externe						
100 VAC	100 V ca	Rated Load Voltage	Tension nominale d'entrée						
Model	Modèle	The external load power supply section is as shown below.	La section alimentation de la charge externe est comme représenté ci-dessous.						



(5)	Model	Rated Load Voltage	(6)	Model	Rated Load Voltage
	A1SY22	100 to 240 VAC		A1SY28A	100 to 240 VAC
(7)	Model	Rated Load Voltage	(8)	Model	Rated Load Voltage
	A1SY28EU	100 to 240 VAC		A1SY40 A1SY40P	12/24 VDC
English	French	English	French		
100 to 240 VAC	de 100 à 240 V ca	12/24 VDC	12/24 V cc		
Model	Modèle	Rated Load Voltage	Tension nominale d'entrée		

(9)	Model	Rated Load Voltage
	A1SY50	12/24 VDC
	A1SY60	24 VDC

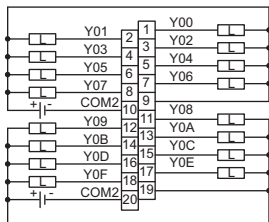

(10)	Model	Rated Load Voltage
	A1SY60E	5/12/24 VDC

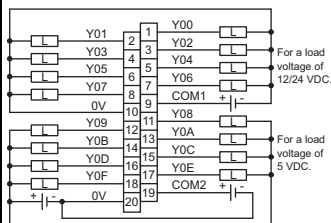

- \* When using a working load voltage of 5VDC, a separate 12/24VDC source is required for the external power supply.
- \* *Pour utiliser une tension de charge utile de 5 V cc, il faut une source séparée 12/24 V cc pour l'alimentation externe.*

(11)	Model	Rated Load Voltage
	A1SY68A	5/12/24/48 VDC

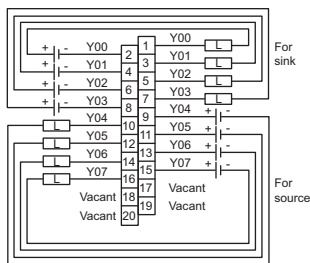

(12)	Model	Rated Load Voltage
	A1SY80	12/24 VDC

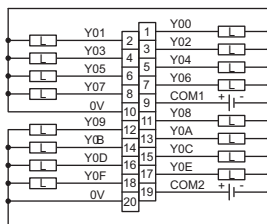

English	French	English	French
100 to 240 VAC	<i>de 100 à 240 V ca</i>	For a load voltage of 12/24 VDC.	<i>Pour une tension de charge de 12/24 V cc.</i>
For sink	<i>Pour dissipateur</i>	For a load voltage of 5 VDC.	<i>Pour une tension de charge de 5 V cc.</i>
For source	<i>Pour source</i>	Model	<i>Modèle</i>
Vacant	<i>Libre</i>	Rated Load Voltage	<i>Tension nominale d'entrée</i>
VDC	<i>V cc</i>		

(13)	Model	Rated Load Voltage
	A1SY41	12/24 VDC
	A1SY41P	

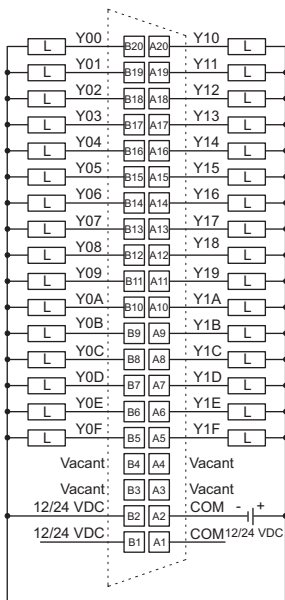

- \*1 [B1] and [B2], and [A1] and [A2] are connected internally.
- \*2 The A and B pin number rows shown above are transposed with respect to the diagram of the A and B rows which is printed on the module. Remember that the A row pin numbers correspond to the B row of the module.
- \*1 [B1] et [B2], ainsi que [A1] et [A2], sont connectés à l'intérieur.
- \*2 Les rangées de broches A et B ci-dessous correspondent aux rangées de broches marquées A et B sur le schéma imprimé sur le module. Noter que les numéros de broche de rangée A correspondent à la rangée B sur le module.

English	French	English	French
12/24 VDC	12/24 V cc	Model	Modèle
Vacant	Libre	Rated Load Voltage	Tension nominale d'entrée

(14)	Model	Rated Load Voltage
	A1SY42	12/24 VDC
	A1SY42P	

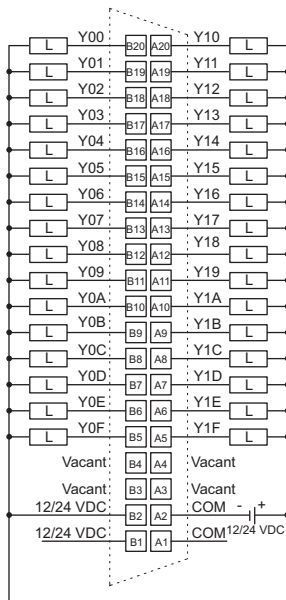

\*1 The figure above indicates **[F]** (the first half 32 points). The connections for **[L]** (the latter half 32 points) are the same as for **[F]** (regard Y00 to Y1F as Y20 to Y3F.)

**[B1]** and **[B2]**, and **[A1]** and **[A2]**, are connected internally.

\*2 The A and B pin number rows shown above are transposed with respect to the diagram of the A and B rows which is printed on the module. Remember that the A row pin numbers correspond to the B row of the module.

\*1 La figure ci-dessus représente **[F]** (première moitié de 32 points).

Les connexions pour **[L]** (deuxième moitié de 32 points) sont comme pour **[F]** (considérer X00 à X1F comme état X20 à X3F.)

**[B1]** et **[B2]**, ainsi que **[A1]** et **[A2]**, sont connectés à l'intérieur.

\*2 Les rangées de broches A et B ci-dessous correspondent aux rangées de broches marquées A et B sur le schéma imprimé sur le module. Noter que les numéros de broche de rangée A correspondent à la rangée B sur le module.

English	French	English	French
12/24 VDC	12/24 V cc	Model	Modèle
Vacant	Libre	Rated Load Voltage	Tension nominale d'entrée

(15)	Model	Rated Load Voltage
	A1SY71	5/12 VDC

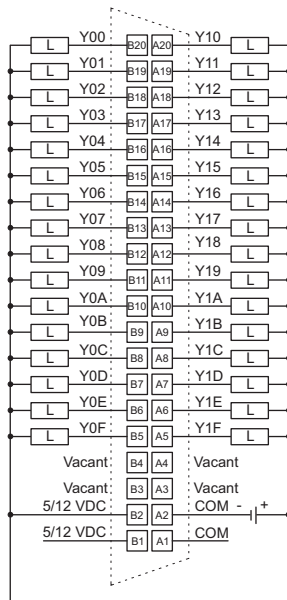

- \*1 [B1] and [B2], and [A1] and [A2], are connected internally.
- \*2 The A and B pin number rows shown above are transposed with respect to the diagram of the A and B rows which is printed on the module. Remember that the A row pin numbers correspond to the B row of the module.
- \*1 [B1] et [B2], ainsi que [A1] et [A2], sont connectés à l'intérieur.
- \*2 Les rangées de broches A et B ci-dessous correspondent aux rangées de broches marquées A et B sur le schéma imprimé sur le module. Noter que les numéros de broche de rangée A correspondent à la rangée B sur le module.

English	French	English	French
12/24 VDC	12/24 V cc	Model	Modèle
Vacant	Libre	Rated Load Voltage	Tension nominale d'entrée

(16)	Model	Rated Load Voltage
	A1SY81	12/24 VDC
	A1SY81EP	

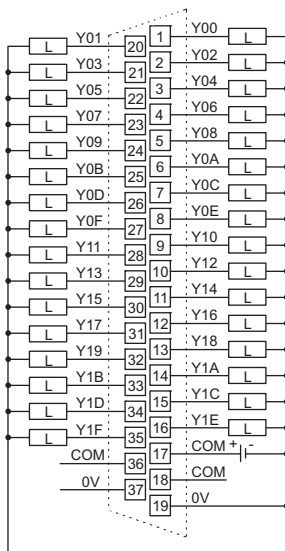

- [17] and [18] and [36], and [19] and [37] are connected internally.
- [17], [18] et [36], ainsi que [19] et [37], sont connectés à l'intérieur.

English	French	English	French
12/24 VDC	12/24 V cc	Model	Modèle
Vacant	Libre	Rated Load Voltage	Tension nominale d'entrée

(17)	Model	Rated Load Voltage
	A1SY82	12/24 VDC



- \*1 The figure above indicates [F] (the first half 32 points).  
The connections for [L] (the latter half 32 points) are the same as for [F] (regard Y00 to Y1F as Y20 to Y3F.)  
[B1] and [B2], and [A1] and [A2], are connected internally.
- \*2 The A and B pin number rows shown above are transposed with respect to the diagram of the A and B rows which is printed on the module. Remember that the A row pin numbers correspond to the B row of the module.
- \*1 La figure ci-dessus représente [F] (première moitié de 32 points).  
Les connexions pour [L] (deuxième moitié de 32 points) sont comme pour [F] (considérer X00 à X1F comme état X20 à X3F.)  
[B1] et [B2], ainsi que [A1] et [A2], sont connectés à l'intérieur.
- \*2 Les rangées de broches A et B ci-dessous correspondent aux rangées de broches marquées A et B sur le schéma imprimé sur le module. Noter que les numéros de broche de rangée A correspondent à la rangée B sur le module.

English	French	English	French
12/24 VDC	12/24 V cc	Model	Modèle
Vacant	Libre	Rated Load Voltage	Tension nominale d'entrée

(18)	Model	Rated Load Voltage
	A1S42Y	12/24 VDC

### Pin Arrangement

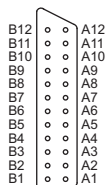

Seen from front face of the module

Pin No.	Signal Name (F <sub>H</sub> )	Pin No.	Signal Name (F <sub>H</sub> )
B12	YD0	A12	YD1
B11	YD2	A11	YD3
B10	YD4	A10	YD5
B9	YD6	A9	YD7
B8	YSCN0	A8	YSCN1
B7	YSCN2	A7	YSCN3
B6	YSCN4	A6	YSCN5
B5	YSCN6	A5	YSCN7
B4	Vacant	A4	Vacant
B3	12/24 VDC	A3	12/24 VDC
B2	0V	A2	0V
B1	Vacant	A1	Vacant

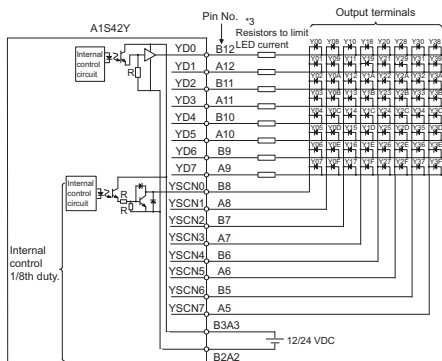

\*1 The fuse in the output module is provided to prevent the external wiring from burning in the event of a short circuit in the module's output. Consequently, it may not be able to protect output devices.  
If an output device is damaged in a failure mode other than a short circuit, the fuse might not be blown.

\*2 The "ERR." LED will also come ON when the external power supply is cut.

\*3 Mount the resistors to limit LED current externally to the A1S42Y.

\*4 The power supply voltage (12/24VDC) is applied in the LED's reverse direction.  
If the peak inverse voltage is insufficient, connect protective diodes in series with each of the LEDs.



\*1 *Le rôle du fusible du module de sortie est d'éviter d'endommager le câblage externe dans l'éventualité d'un court-circuit de la sortie de module. Il ne peut donc assurer la protection des dispositifs de sortie.*

*Si un dispositif de de sortie est endommagé en un mode de défaillance autre qu'un court-circuit, il se peut que le fusible ne saute pas.*

\*2 *La diode lumineuse "ERR" s'allume aussi quand l'alimentation externe est coupée.*

\*3 *Installer des résistances pour limiter le courant LED à l'extérieur du A1S42Y.*

\*4 *La tension d'alimentation (12/24 V cc) s'exerce en sens inverse de la LED.*



*Si la tension inverse de pointe est insuffisante, raccorder des diodes de protection en série avec chacune des LED.*



English	French	English	French
Model	<i>Modèle</i>	Internal control circuit	<i>Circuit de commande interne</i>
Output terminals	<i>Bornes de sortie</i>	Internal control 1/8th duty	<i>Commande interne facteur d'utilisation 1/8ème</i>
Pin No.	<i>Broche N°</i>	Pin Arrangement	<i>Attribution des broches</i>
Signal Name	<i>Nom de signal</i>	Rated Load Voltage	<i>Tension nominale d'entrée</i>
Vacant	<i>Libre</i>	Resistors to limit LED current	<i>Résistance de limitation du courant LED</i>
VDC	<i>V<sub>cc</sub></i>	Seen from front face of the module	<i>Vu depuis le devant du module</i>

## 5.3 Input/output combined modules

### 5.3.1 Input/output combined module specifications

Model	Type	No. of Points	Rated Input Voltage	Input Current	Operating Voltage	
					ON Voltage	OFF Voltage
A1SH42	DC Input (sink type)	32	12/24VDC	2/5mA	8VDC or higher	4VDC or lower
A1SH42P						
A1SH42-S1			24VDC	5mA	15VDC or higher	3VDC or lower
A1SH42P-S1						
A1SX48Y18		8	24VDC	7mA	14VDC or higher	6.5VDC or lower
A1SX48Y58						

Model	Type	No. of Points	Rated Load Voltage	Max. Load Current		Max. Output Response Time	
				1 Point	Common	OFF to ON	ON to OFF
A1SH42	Transistor Output (sink type)	32	12/24VDC	0.1A	1.6A	2ms or lower	2ms or lower
A1SH42P					2A	1ms or lower	1ms or lower
A1SH42-S1					1.6A	2ms or lower	2ms or lower
A1SH42P-S1					2A	1ms or lower	1ms or lower
A1SX48Y18	Relay Output	8	24VDC 240VAC	2A	8A	10ms or lower	12ms or lower
A1SX48Y58	Transistor Output (sink type)		12/24VDC	0.5A	2A	2ms or lower	2ms or lower

For all modules, the insulation system is photocoupler insulation and the operation status is provided by LED indications.

	Max. Simultaneous Input Points (Percentage Simultaneously ON)	Max. Response Time		No. of Occupied Points
		OFF to ON	ON to OFF	
	60%(24VDC)	10ms or lower	10ms or lower	32
		0.3ms or lower	0.3ms or lower	
	100%(26.4VDC)	10ms or lower	10ms or lower	8

	Points/ Common	Field Wiring	Surge Suppression	Fuse Rating	External Power Supply (TYP 24VDC)	External Current Consumption (5VDC)	No. of Occupied Points
					Current		
	32	40-pin Connector	Zener diode	3.2A	0.008A	0.5A	32
				None	0.012A	0.13A	
				3.2A	0.008A	0.5A	
				None	0.012A	0.13A	
	8	Terminal	None	None	0.045A	0.085A	16
			Zener diode	3.2A	0.06A	0.06A	

## 5.3.2 Input/output composite module connections

### Connexions du module composite entrée/sortie

	Model	Rated Input Voltage	Rated Load Voltage
(1)	A1SH42	12/24 VDC	12/24 VDC
	A1SH42P		
	A1SH42-S1	24 VDC	12/24 VDC
	A1SH42P-S1		

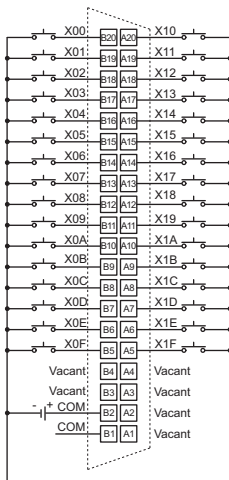

**X** (Input side)  
(Côté entrée)

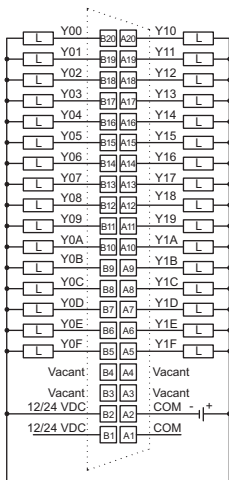

**Y** (Output side)  
(Côté sortie)

\*1 **B1** and **B2** are connected internally.

\*1 **B1** et **B2** sont connectés à l'intérieur.

\*3 **B1** and **B2**, and **A1** and **A2**, are connected internally.

\*3 **B1** et **B2**, ainsi que **A1** et **A2**, sont connectés à l'intérieur.

\*2 The A and B pin number rows shown above are transposed with respect to the diagram of the A and B rows which is printed on the module. Remember that the A row pin numbers correspond to the B row of the module.

\*2 Les rangées de broches A et B ci-dessous correspondent aux rangées de broches marquées A et B sur le schéma imprimé sur le module. Noter que les numéros de broche de rangée A correspondent à la rangée B sur le module.

English	French	English	French
Vacant	Libre	Model	Modèle
VDC	V cc	Rated Load Voltage	Tension nominale d'entrée

(2)	Model	Rated Input Voltage	Rated Load Voltage
	A1SX48Y18	24 VDC	24 VDC/ 240 VAC

(3)	Model	Rated Input Voltage	Rated Load Voltage
	A1SX48Y58	24 VDC	12/24 VDC

English	French	English	French
For relay drive	Pour attaque du relais	VAC	V ca
VDC	V cc	Vacant	Libre
Model	Modèle	Rated Load Voltage	Tension nominale d'entrée

---

---

## **6. ERROR CODES**

---

---

If a fault occurs at the start or during RUN of the programmable controller, the self-diagnostics function gives an error indication or stores an error code (including the step number) in the special register.

### **6.1 Reading the Error Code**

If an error occurs, its code, message and others can be read with a peripheral device.

For details of how to operate the peripheral device, refer to the operating manual of your peripheral device.

## 6.2 Error Code List

This section explains the error definitions, causes and actions of error codes, error messages and detailed error codes.

Table 6.1 Error Code List

Error Message	Error Code (D9008)	Detailed Error Code (D9091)	CPU States	Error and Cause	Corrective Action
"INSTRUCT CODE ERR"  (Checked when STOP → RUN or at execution of instruction.)	10	101	STOP	Instruction codes which the CPU module cannot decode are included in the program.	(1) Read the error step using a peripheral device and correct the program of the step. (2) Check the ROM if it contains instruction codes which cannot be decoded. If it does, replace it with a correct ROM.
		102		Index qualification is specified for a 32-bit constant.	Read the error step using a peripheral device and correct the program of the step.
		103		Device specified by a dedicated instruction is not correct.	
		104		A dedicated instruction has incorrect program structure.	
		105		A dedicated instruction has incorrect command name.	
		106		Index qualification using Z or V is included in the program between LEDA/BIXI and LEDA/BIXENDI.	

Table 6.1 Error Code List (Continue)

Error Message	Error Code (D9008)	Detailed Error Code (D9091)	CPU States	Error and Cause	Corrective Action
"INSTRUCT CODE ERR"  (Checked when STOP → RUN or at execution of instruction.)	10	107	STOP	(1) Index qualification is specified for the device numbers and set values in the OUT instruction of timers and counters. (2) Index qualification is specified at the label number of the pointer (P) provided to the head of destination of the <u>CJ</u> , <u>SCJ</u> , <u>CALL</u> , <u>CALLP</u> , <u>JMP</u> , <u>LEDA/BFCALL</u> and <u>LEDA/BBREAK</u> instructions or at the label number of the interrupt pointer (I) provided to the head of an interrupt program.	Read the error step using a peripheral device and correct the program of the step.
		108		Errors other than 101 to 107 mentioned above.	
"PARAMETER ERROR"  (Checked at power on and at STOP/ PAUSE → RUN.)	11	111	STOP	Capacity settings of the main and sub programs, microcomputer program, file register comments, status latch, sampling trace and extension file registers are not within the usable range of the CPU.	Read parameters in the CPU memory, check the contents, make necessary corrections and write them again to the memory.
		112		Total of the set capacity of the main and sub programs, file register comments, status latch, sampling trace and extension file registers exceeds capacity of the memory cassette.	
		113		Latch range set by parameters or setting of M, L or S is incorrect.	
		114		Sum check error	



Table 6.1 Error Code List (Continue)

Error Message	Error Code (D9008)	Detailed Error Code (D9091)	CPU States	Error and Cause	Corrective Action
"PARAMETER ERROR"  (Checked at power on and at STOP/PAUSE → RUN.)	11	115	STOP	Either of settings of the remote RUN/PAUSE contact point by parameters, operation mode at occurrence of error, annunciator indication mode, or STOP RUN indication mode is incorrect.	Read parameters in the CPU memory, check the contents, make necessary corrections and write them again to the memory.
		116		The MNET-MINI automatic refresh setting by parameters is incorrect.	
		117		Timer setting by parameters is incorrect.	
		118		Counter setting by parameters is incorrect.	
"MISSING END INS"  (Checked at STOP → RUN.)	12	121	STOP	The END (FEND) instruction is not given in the main program.	Write the END instruction at the end of the main program.
		122		The END (FEND) instruction is not given in the sub program if the sub program is set by parameters.	Write the END instruction at the end of the sub program.
"CAN'T EXECUTE (P)"  (Checked at execution of instruction.)	13	131	STOP	The same device number is used at two or more steps for the pointers (P) and interrupt pointers (I) used as labels to be specified at the head of jump destination.	Eliminate the same pointer numbers provided at the head of jump destination.
		132		Label of the pointer (P) specified in the CJ, SCJ, CALL, CALLP, JMP, LEDA/BFCALL or LEDA/BBREAK instruction is not provided before the END instruction.	Read the error step using a peripheral device, check contents and insert a jump destination pointer (P).

Table 6.1 Error Code List (Continue)

Error Message	Error Code (D9008)	Detailed Error Code (D9091)	CPU States	Error and Cause	Corrective Action
"CAN'T EXECUTE (P)"	13	133	STOP	<p>(1) The <u>RET</u> instruction was included in the program and executed though the <u>CALL</u> instruction was not given.</p> <p>(2) The <u>NEXT</u> and <u>LEDA/BBREAK</u> instructions were included in the program and executed though the <u>FOR</u> instruction was not given.</p> <p>(3) Nesting level of the <u>CALL</u>, <u>CALLP</u> and <u>FOR</u> instructions is 6 levels or deeper, and the 6th level was executed.</p> <p>(4) There is no <u>RET</u> or <u>NEXT</u> instruction at execution of the <u>CALL</u> or <u>FOR</u> instruction.</p>	<p>(1) Read the error step using a peripheral device, check contents and correct program of the step.</p> <p>(2) Reduce the number of nesting levels of the <u>CALL</u>, <u>CALLP</u> and <u>FOR</u> instructions to 5 or less.</p>
		134		The <u>CHG</u> instruction was included in the program and executed though no sub program was provided.	Read the error step using a peripheral device and delete the <u>CHG</u> instruction circuit block.
		135		<p>(1) <u>LEDA/BIX</u> and <u>LEDA/BIXEND</u> instructions are not paired.</p> <p>(2) There are 33 or more sets of <u>LEDA/BIX</u> and <u>LEDA/BIXEND</u> instructions.</p>	<p>(1) Read the error step using a peripheral device, check contents and correct program of the step.</p> <p>(2) Reduce the number of sets of <u>LEDA/BIX</u> and <u>LEDA/BIXEND</u> instructions to 32 or less.</p>
(Checked at execution of instruction.)					

Table 6.1 Error Code List (Continue)

Error Message	Error Code (D9008)	Detailed Error Code (D9091)	CPU States	Error and Cause	Corrective Action
"CHK FORMAT ERR"      (Checked at STOP/ PAUSE → RUN.)	14	141	STOP	Instructions (including <code>NOP</code> ) other than <code>LDX</code> , <code>LDIX</code> , <code>ANDX</code> and <code>ANIX</code> are included in the <code>CHK</code> instruction circuit block.	Check the program of the <code>CHK</code> instruction and correct it referring to contents of detailed error codes.
		142		Multiple <code>CHK</code> instructions are given.	
		143		The number of contact points in the <code>CHK</code> instruction circuit block exceeds 150.	
		144		The <code>LEDA CHK</code> instructions are not paired with the <code>LEDA CHKEND</code> instructions, or 2 or more pairs of them are given.	
		145		Format of the block shown below, which is provided before the <code>CHK</code> instruction circuit block, is not as specified. <code>P254 --- CHKD1D2 </code>	
		146		Device number of D1 in the <code>CHKD1D2</code> instruction is different from that of the contact point before the <code>CJ P;</code> instruction.	
		147		Index qualification is used in the check pattern circuit.	

Table 6.1 Error Code List (Continue)

Error Message	Error Code (D9008)	Detailed Error Code (D9091)	CPU States	Error and Cause	Corrective Action
"CHK FORMAT ERR"          (Checked at STOP/ PAUSE → RUN.)	14	148	STOP	<p>(1) Multiple check pattern circuits of the <code>LEDA[CHK] - LEDA[CHKEND]</code> instructions are given.</p> <p>(2) There are 7 or more check condition circuits in the <code>LEDA[CHK] - LEDA[CHKEND]</code> instructions.</p> <p>(3) The check condition circuits in the <code>LEDA[CHK] - LEDA[CHKEND]</code> instructions are written without using X and Y contact instructions or compare instructions.</p> <p>(4) The check pattern circuits of the <code>LEDA[CHK] - LEDA[CHKEND]</code> instructions are written with 257 or more steps.</p>	Check the program of the <code>CHK</code> instruction and correct it referring to contents of detailed error codes.
"CAN'T EXECUTE (I)"          (Checked at occurrence of interrupt.)	15	151	STOP	The <code>IRET</code> instruction was given outside of the interrupt program and was executed.	Read the error step using a peripheral device and delete the <code>IRET</code> instruction.
		152		There is no <code>IRET</code> instruction in the interrupt program.	Check the interrupt program if the <code>IRET</code> instruction is given in it. Write the <code>IRET</code> instruction if it is not given.
		153		Though an interrupt module is used, no interrupt pointer (I) which corresponds to the module is given in the program. Upon occurrence of error, the problem pointer (I) number is stored at D9011.	Monitor special register D9011 using a peripheral device, and check if the interrupt program that corresponds to the stored data is provided or if two or more interrupt pointers (I) of the same number are given. Make necessary corrections.

Table 6.1 Error Code List (Continue)

Error Message	Error Code (D9008)	Detailed Error Code (D9091)	CPU States	Error and Cause	Corrective Action
"CASSETTE ERROR"	16	—	STOP	(1) A memory card is inserted or removed while the CPU module is ON. (2) An invalid memory card is inserted.	(1) Do not insert or remove a memory card while the CPU module is ON. (2) Insert an available memory card.
"RAM ERROR"	20	201	STOP	The sequence program storage RAM in the CPU module caused an error.	Since this is CPU hardware error, consult Mitsubishi representative.
(Checked at power on.)		202		The work area RAM in the CPU module caused an error.	
		203		The device memory in the CPU module caused an error.	
"RAM ERROR" (Checked at execution of END processing.)		204		The address RAM in the CPU module caused an error.	
"OPE CIRCUIT ERROR"	21	211	STOP	The operation circuit for index qualification in the CPU does not work correctly.	Since this is CPU hardware error, consult Mitsubishi representative.
(Checked at power on.)		212		Hardware (logic) in the CPU does not operate correctly.	
		213		The operation circuit for sequential processing in the CPU does not operate correctly.	
		"OPE. CIRCUIT ERR."		214	
(Checked at execution of the END instruction.)		215		In the END processing check, the hardware in the CPU does not operate correctly.	

Table 6.1 Error Code List (Continue)

Error Message	Error Code (D9008)	Detailed Error Code (D9091)	CPU States	Error and Cause	Corrective Action
"WDT ERROR"  (Checked at execution of END processing.)	22	—	STOP	Scan time is longer than the WDT time. (1) Scan time of the user's program has been extended due to certain conditions. (2) Scan time has been extended due to momentary power failure occurred during scanning.	(1) Check the scan time of the user's program and shorten it using the [CJ] instructions. (2) Monitor contents of special register D9005 using a peripheral device. If the contents are other than 0, power supply voltage may not be stable. Check power supply and reduce variation in voltage.
"END NOT EXECUTE"  (Checked at execution of the END instruction.)	24	241	STOP	Whole program of specified program capacity was executed without executing the <u>END</u> instructions. (1) When the <u>END</u> instruction was to be executed, the instruction was read as other instruction code due to noise. (2) The <u>END</u> instruction changed to other instruction code due to unknown cause.	(1) Reset and run the CPU again. If the same error recurs, Since this is CPU hardware error, consult Mitsubishi representative.
"MAIN CPU DOWN"	26	—	STOP	The main CPU is malfunctioning or faulty.	Since this is CPU hardware error, consult Mitsubishi representative.

Table 6.1 Error Code List (Continue)

Error Message	Error Code (D9008)	Detailed Error Code (D9091)	CPU States	Error and Cause	Corrective Action
"UNIT VERIFY ERR"  (Checked continuously.)	31	—	Stop or Continue (set by parameter)	Current I/O module information is different from that recognised when the power was turned on. (1) The I/O module (including special function modules) connection became loose or the module was disconnected during operation, or wrong module was connected.	Read detailed error code using a peripheral device and check or replace the module which corresponds to the data (I/O head number). Or, monitor special registers D9116 to D9123 using a peripheral device and check or replace the modules if corresponding data bit is "1".
"FUSE BREAK OFF"  (Checked continuously.)	32	—	Stop or Continue (set by parameter)	(1) There is an output module of which fuse is blown. (2) The external power supply for output load is turned OFF or is not connected.	(1) Check the FUSE BLOWN indicator LED on the output module and replace the fuse. (2) Read detailed error code using a peripheral device and replace the fuse of the output module which corresponds to the data (I/O head number). Or, monitor special registers D9100 to D9107 using a peripheral device and replace the fuse of the output module of which corresponding data bit is "1". (3) Check the ON/OFF status of the external power supply for output load.

Table 6.1 Error Code List (Continue)

Error Message	Error Code (D9008)	Detailed Error Code (D9091)	CPU States	Error and Cause	Corrective Action
"CONTROL-BUS ERR"	40	401	STOP	Due to the error of the control bus which connects to special function modules, the FROM/TO instruction cannot be executed.	Since it is a hardware error of special function module, CPU module or base module, replace and check defective module(s). Consult Mitsubishi representative for defective modules.
		402		If parameter I/O assignment is being executed, special function modules are not accessible at initial communication. At error occurrence, the head I/O number (upper 2 digits of 3 digits) of the special function module that caused error is stored at D9010.	
		403		Hardware failure.	
		405		(1) The expansion cable is not properly connected. (2) QA1S base failure. The base information is different from that obtained at power on. The failed base is stored in D9068 as a bit pattern. The failed base is stored in D9010 from the upper stage.	(1) Connect the expansion cable properly. (2) The hardware failure occurs in the special function, CPU, or base module. Replace the module and find the faulty one. Describe the problem to the nearest system service, retail store, or corporate office, and obtain advice.



Table 6.1 Error Code List (Continue)

Error Message	Error Code (D9008)	Detailed Error Code (D9091)	CPU States	Error and Cause	Corrective Action
"SP.UNIT DOWN"	41	411	STOP	Though an access was made to a special function module at execution of the FROM/TO instruction no response is received.	Since it is hardware error of the special function module to which an access was made, consult Mitsubishi representative.
		412		If parameter I/O assignment is being executed, no response is received from a special function module at initial communication. At error occurrence, the head I/O number (upper 2 digits of 3 digits) of the special function module that caused error is stored at D9011.	
"LINK UNIT ERROR"	42	—	Continue	Two of data link module is specified as master stations.	Specify one of data link module as a master station and another as a local station.
"I/O INT. ERROR"	43	—	STOP	Though the interrupt module is not loaded, an interrupt occurred.	Since it is hardware error of a module, replace and check a defective module. For defective modules, consult Mitsubishi representative.
"SP.UNIT LAY.ERR."	44	441	STOP	A special function module is assigned as an I/O module, or vice versa, in the I/O assignment using parameters from the peripheral device.	Execute I/O assignment again using parameters from the peripheral device according to the loading status of special function modules.
		442		There are 9 or more special function modules (except the interrupt module) which can execute interruption to the CPU module loaded.	Reduce the special function modules (except the interrupt module) which can execute interrupt start to 8 or less.
		443		There are 2 or more data link modules loaded.	Reduce the data link modules to 1 or less.
		444		There are 7 or more modules such as a computer link module loaded to one CPU module.	Reduce the computer link modules to 6 or less.

Table 6.1 Error Code List (Continue)

Error Message	Error Code (D9008)	Detailed Error Code (D9091)	CPU States	Error and Cause	Corrective Action
"SP.UNIT LAY.ERR."	44	445	STOP	There are 2 or more interrupt modules loaded.	Reduce the interrupt modules to 1.
		446		Modules assigned by parameters for MNT/ MINI automatic refresh from the peripheral device do not conform with the types of station modules actually linked.	Perform again module assignment for MNT/ MINI automatic refresh with parameters according to actually linked station modules.
"SP.UNIT LAY.ERR."	44	447	STOP	The number of modules of I/O assignment registration (number of loaded modules) per one CPU module for the special function modules which can use dedicated instructions is larger than the specified limit. (Total of the number of computers shown below is larger than 1344.) $\begin{aligned} & (A1SJ71C24-R2)(PRF/R4) \times 10 \\ & (A1SJ71UC24 \times 10) \\ & (A1SJ71PT32-S3 \times 125) \\ & + (A1SJ71PT32(S3) * \times 125) \\ & \text{Total} > 1344 \end{aligned}$	Reduce the number of loaded special function modules. *Available when the extension mode is used.
		448		(1) Five or more network modules have been installed. (2) A total of five or more of network modules and data link modules have been installed.	(1) Reduce the number to four or less. (2) Reduce the total number to four or less.
		449		An invalid base module is used. Failure of base module hardware.	Use an available base module. Replace the failed base module.

Table 6.1 Error Code List (Continue)

Error Message	Error Code (D9008)	Detailed Error Code (D9091)	CPU States	Error and Cause	Corrective Action
"SP.UNIT ERROR"  (Checked at execution of the FROM/TO instruction or the dedicated instructions for special function modules.)	46	461	Stop or Continue (set by parameter)	Module specified by the FROM/TO instruction is not a special function module.	Read the error step using a peripheral device and check and correct contents of the FROM/TO instruction of the step.
		462		<p>(1) Module specified by the dedicated instruction for special function module is not a special function module or not a corresponding special function module.</p> <p>(2) A command was issued to a CC-Link module with function version under B.</p> <p>(3) A CC-Link dedicated command was issued to a CC-Link module for which the network parameters have not been set.</p>	<p>(1) Read the error step using a peripheral device and check and correct contents of the dedicated instruction for special function modules of the step.</p> <p>(2) Replace with a CC-Link module having function version B and above.</p> <p>(3) Set the parameters.</p>

Table 6.1 Error Code List (Continue)

Error Message	Error Code (D9008)	Detailed Error Code (D9091)	CPU States	Error and Cause	Corrective Action
"LINK PARA. ERROR"	47	0	Stop or Continue (set by parameter)	<p>[When using MELSECNET/(II)]</p> <p>(1) When the link range at a data link CPU which is also a master station (station number = 00) is set by parameter setting at a peripheral device, for some reason the data written to the link parameter area differs from the link parameter data read by the CPU. Alternatively, no link parameters have been written.</p> <p>(2) The total number of slave stations is set at 0.</p> <p>(3) The head I/O number of the network parameters is incorrect.</p>	<p>(1) Write the parameters again and check.</p> <p>(2) Check the station number settings.</p> <p>(3) Check the head I/O number of the network parameters.</p> <p>(4) Persistent error occurrence may indicate a hardware fault. Consult your nearest Mitsubishi representative, explaining the nature of the problem.</p>
		470		<p>[When using MELSECNET/10]</p> <p>(1) The contents of the network refresh parameters written from a peripheral device differ from the actual system at the base unit.</p> <p>(2) The network refresh parameters have not been written.</p> <p>(3) The head I/O number of the network parameters is incorrect.</p>	

Table 6.1 Error Code List (Continue)

Error Message	Error Code (D9008)	Detailed Error Code (D9091)	CPU States	Error and Cause	Corrective Action
"LINK PARA. ERROR"	47	471	Stop or Continue (set by parameter)	[When using MELSECNET/10] (1) The transfer source device range and transfer destination device range specified for the inter-network transfer parameters are in the same network. (2) The specified range of transfer source devices or transfer destination devices for the inter-network transfer parameters spans two or more networks. (3) The specified range of transfer source devices or transfer destination devices for the inter-network transfer parameters is not used by the network.	(1) Write the parameters again and check. (2) Check the station number settings. (3) Check the head I/O number of the network parameters. (4) Persistent error occurrence may indicate a hardware fault. Consult your nearest Mitsubishi representative, explaining the nature of the problem.
		472		[When using MELSECNET/10] The contents of the routing parameters written from a peripheral device differ from the actual network system.	Write the network refresh parameters again and check.

Table 6.1 Error Code List (Continue)

Error Message	Error Code (D9008)	Detailed Error Code (D9091)	CPU States	Error and Cause	Corrective Action
"LINK PARA. ERROR"	47	473	Stop or Continue (set by parameter)	[When using MELSECNET/10] (1) The contents of the network parameters for the first link unit, written from a peripheral device, differ from the actual network system. (2) The link parameters for the first link unit have not been written. (3) The setting for the total number of stations is 0.	(1) Write the parameters again and check. (2) Check the station number settings. (3) Persistent error occurrence may indicate a hardware fault. Consult your nearest Mitsubishi representative, explaining the nature of the problem.
		474		[When using MELSECNET/10] (1) The contents of the network parameters for the second link unit, written from a peripheral device, differ from the actual network system. (2) The link parameters for the second link unit have not been written. (3) The setting for the total number of stations is 0.	(1) Write the parameters again and check. (2) Check the station number settings. (3) Persistent error occurrence may indicate a hardware fault. Consult your nearest Mitsubishi representative, explaining the nature of the problem.
		475		[When using MELSECNET/10] (1) The contents of the network parameters for the third link unit, written from a peripheral device, differ from the actual network system. (2) The link parameters for the third link unit have not been written. (3) The setting for the total number of stations is 0.	(1) Write the parameters again and check. (2) Check the station number settings. (3) Persistent error occurrence may indicate a hardware fault. Consult your nearest Mitsubishi representative, explaining the nature of the problem.

Table 6.1 Error Code List (Continue)

Error Message	Error Code (D9008)	Detailed Error Code (D9091)	CPU States	Error and Cause	Corrective Action
"LINK PARA. ERROR"	47	476	Stop or Continue (set by parameter)	[When using MELSECNET/10] (1) The contents of the network parameters for the fourth link unit, written from a peripheral device, differ from the actual network system. (2) The link parameters for the fourth link unit have not been written. (3) The setting for the total number of stations is 0.	(1) Write the parameters again and check. (2) Check the station number settings. (3) Persistent error occurrence may indicate a hardware fault. Consult your nearest Mitsubishi representative, explaining the nature of the problem.
		477		A link parameter error was detected by the CC-Link module.	
"OPERATION ERROR"  (Checked at execution of instruction.)	50	501	Stop or Continue (set by parameter)	(1) When file registers (R) are used, operation is executed outside of specified ranges of device numbers and block numbers of file registers (R). (2) File registers are used in the program without setting capacity of file registers.	Read the error step using a peripheral device and check and correct program of the step.
		502		Combination of the devices specified by instruction is incorrect.	
		503		Stored data or constant of specified device is not in the unable range.	
		504		Set number of data to be handled is out of the unable range.	

Table 6.1 Error Code List (Continue)

Error Message	Error Code (D9008)	Detailed Error Code (D9091)	CPU States	Error and Cause	Corrective Action
"OPERATION ERROR"	50	505	Stop or Continue (set by parameter)	(1) Station number specified by the <u>LEDA/BLRDP</u> , <u>LEDA/BLWTP</u> , <u>LRDP</u> , <u>LWTP</u> instructions is not a local station. (2) Head I/O number specified by the <u>LEDA/BRFRP</u> , <u>LEDA/BRTOP</u> , <u>RFRP</u> , <u>RTOP</u> instructions is not of a remote station.	Read the error step using a peripheral device and check and correct program of the step.
		506		Head I/O number specified by the <u>LEDA/BRFRP</u> , <u>LEDA/BRTOP</u> , <u>RFRP</u> , <u>RTOP</u> instructions is not of a special function module.	
		507		(1) When the AD57(S1) or AD58 was executing instructions in divided processing mode, other instructions were executed to either of them. (2) When an AD57(S1) or AD58 was executing instructions in divided processing mode, other instructions were executed in divided mode to another AD57(S1) or AD58.	AD57 (S1) and AD58 cannot be used with QCPU-A. Review the program.
		508		A CC-Link dedicated command was issued to three or more CC-Link modules.	The CC-Link dedicated command can be issued only to two or less CC-Link modules.
(Checked at execution of instruction.)					



Table 6.1 Error Code List (Continue)

Error Message	Error Code (D9008)	Detailed Error Code (D9091)	CPU States	Error and Cause	Corrective Action
"OPERATION ERROR"	50	509	Stop or Continue (set by parameter)	<p>(1) An instruction which cannot be executed by remote terminal modules connected to the MNET/MINI-S3 was executed to the modules.</p> <p>(2) Though there are 32 entries of FROM or TO instructions registered with a PRC instruction in the mailbox (memory area waiting for execution), another PRC instruction is executed to cause an overflow in the mailbox (memory area waiting for execution).</p> <p>(3) The PIDCONT instruction was executed without executing the PIDINIT instruction. The PID57 instruction was executed without executing the PIDINIT or PIDCONT instruction. The program presently executed was specified by the ZCHG instruction.</p> <p>(4) The number of CC-Link dedicated command executed in one scan exceeded 10.</p>	<p>(1) Read the error step using a peripheral device and correct the program, meeting loaded conditions of remote terminal modules.</p> <p>(2) Use special register D9081 (number of empty entries in mailbox) or special relay M9081 (BUSY signal of mailbox) to suppress registration or execution of the PRC instruction.</p> <p>(3) Correct the program specified by the ZCHG instruction to other.</p> <p>(4) Set the number of CC-Link dedicated commands executed in one scan to 10 or less.</p>
(Checked at execution of instruction.)					

Table 6.1 Error Code List (Continue)

Error Message	Error Code (D9008)	Detailed Error Code (D9091)	CPU States	Error and Cause	Corrective Action
"MAINCPU DOWN"	60	—	STOP	(1) The CPU malfunctioned due to noise. (2) Hardware failure.	(1) Take proper countermeasures for noise. (2) Since it is hardware error, consult Mitsubishi representative.
	61				
	62			(1) The power supply module detected an incorrect power waveform. (2) Failure of the power module, CPU module, main base unit or expansion cable is detected.	(1) Correct the power waveform applied to the power supply module. (2) Replace the power module, CPU module, main base unit or expansion cable.
"BATTERY ERROR"  (Checked at power on.)	70	—	Continue	(1) The battery voltage for the CPU module has dropped below the specified value. (2) The lead connector of the CPU module battery is disconnected. (M9006 is ON.) (3) The battery voltage for the memory card has dropped below the specified value. (M9048 is ON.)	(1) Replace the battery of the CPU module. (2) Connect the lead connector when using the built-in RAM or the memory retention function during power failure. (3) Replace the battery of the memory card.

---

---

## 7. TRANSPORTATION PRECAUTIONS

---

---

When transporting lithium batteries, make sure to treat them based on the transportation regulations.

### 7.1 Relevant Models

The batteries for the QCPU-A is classified as shown in the table below.

Product Name	Model	Description	Handled As
Battery	Q6BAT	Lithium battery	Non-dangerous goods
SRAM card battery	Q2MEM-BAT	Lithium coin battery	
Memory card	Q2MEM-1MBS	Packed with lithium coin battery(Q2MEM-BAT)	

### 7.2 Transportation Guidelines

Products are packed properly in compliance with the transportation regulations prior to shipment. When repacking any of the unpacked products to transport it to another location, make sure to observe the IATA Dangerous Goods Regulations, IMDG Code and other local transportation regulations.

For details, please consult your transportation company.



## **WARRANTY**

Please confirm the following product warranty details before using this product.

### **1. Gratis Warranty Term and Gratis Warranty Range**

If any faults or defects (hereinafter "Failure") found to be the responsibility of Mitsubishi occurs during use of the product within the gratis warranty term, the product shall be repaired at no cost via the sales representative or Mitsubishi Service Company.

However, if repairs are required onsite at domestic or overseas location, expenses to send an engineer will be solely at the customer's discretion. Mitsubishi shall not be held responsible for any re-commissioning, maintenance, or testing on-site that involves replacement of the failed module.

#### **[Gratis Warranty Term]**

The gratis warranty term of the product shall be for one year after the date of purchase or delivery to a designated place.

Note that after manufacture and shipment from Mitsubishi, the maximum distribution period shall be six (6) months, and the longest gratis warranty term after manufacturing shall be eighteen (18) months. The gratis warranty term of repair parts shall not exceed the gratis warranty term before repairs.

#### **[Gratis Warranty Range]**

- (1)The range shall be limited to normal use within the usage state, usage methods and usage environment, etc., which follow the conditions and precautions, etc., given in the instruction manual, user's manual and caution labels on the product.
- (2)Even within the gratis warranty term, repairs shall be charged for in the following cases.
  - 1.Failure occurring from inappropriate storage or handling, carelessness or negligence by the user. Failure caused by the user's hardware or software design.
  - 2.Failure caused by unapproved modifications, etc., to the product by the user.
  - 3.When the Mitsubishi product is assembled into a user's device, Failure that could have been avoided if functions or structures, judged as necessary in the legal safety measures the user's device is subject to or as necessary by industry standards, had been provided.
  - 4.Failure that could have been avoided if consumable parts (battery, backlight, fuse, etc.) designated in the instruction manual had been correctly serviced or replaced.
  - 5.Failure caused by external irresistible forces such as fires or abnormal voltages, and Failure caused by force majeure such as earthquakes, lightning, wind and water damage.
  - 6.Failure caused by reasons unpredictable by scientific technology standards at time of shipment from Mitsubishi.
  - 7.Any other failure found not to be the responsibility of Mitsubishi or that admitted not to be so by the user.

## **2. Onerous repair term after discontinuation of production**

(1) Mitsubishi shall accept onerous product repairs for seven (7) years after production of the product is discontinued.

Discontinuation of production shall be notified with Mitsubishi Technical Bulletins, etc.

(2) Product supply (including repair parts) is not available after production is discontinued.

## **3. Overseas service**

Overseas, repairs shall be accepted by Mitsubishi's local overseas FA Center. Note that the repair conditions at each FA Center may differ.

## **4. Exclusion of loss in opportunity and secondary loss from warranty liability**

Regardless of the gratis warranty term, Mitsubishi shall not be liable for compensation of damages caused by any cause found not to be the responsibility of Mitsubishi, loss in opportunity, lost profits incurred to the user by Failures of Mitsubishi products, special damages and secondary damages whether foreseeable or not, compensation for accidents, and compensation for damages to products other than Mitsubishi products, replacement by the user, maintenance of on-site equipment, start-up test run and other tasks.

## **5. Changes in product specifications**

The specifications given in the catalogs, manuals or technical documents are subject to change without prior notice.



Country/Region	Sales office/Tel	Country/Region	Sales office/Tel
USA	Mitsubishi Electric Automation Inc. 500 Corporate Woods Parkway, Vernon Hills, IL 60061, USA Tel : +1-847-478-2100	South Africa	CBI-Electric. Private Bag 2016, ZA-1600 Isando, South Africa Tel : +27-11-977-0770
Brazil	MELCO-TEC Representacao Comercial e Assessoria Tecnica Ltda. Av. Paulista, 1439, cj74, Bela Vista, Sao Paulo CEP: 01311-200-SP Brazil Tel : +55-11-3146-2200	China	Mitsubishi Electric Automation (China) Ltd. No.1386 Hongqiao Road, Mitsubishi Electric Automation Center, Changning District, Shanghai, China Tel : +86-21-2322-3030
Germany	Mitsubishi Electric Europe B.V. German Branch Gothaer Strasse 8, D-40880 Ratingen, Germany Tel : +49-2102-486-0	Taiwan	Setsuyo Enterprise Co., Ltd. 6F., No.105, Wugong 3rd Road, Wugu District, New Taipei City 24889, Taiwan, R.O.C. Tel : +886-2-2299-2499
UK	Mitsubishi Electric Europe B.V. UK Branch Travellers Lane, Hatfield, Hertfordshire, AL10 8XB, UK. Tel : +44-1707-27-6100	Korea	Mitsubishi Electric Automation Korea Co., Ltd. 3F, 1480-6, Gayang-Dong, Gangeo-Gu, Seoul, 157-200, Korea Tel : +82-2-3660-9530
Italy	Mitsubishi Electric Europe B.V. Italian Branch Viale Colleoni 7-20864 Agrate Brianza (Milano), Italy Tel : +39-039-60531	Singapore	Mitsubishi Electric Asia Pte, Ltd. Industrial Division 307, Alexandra Road, Mitsubishi Electric Building, Singapore, 159943 Tel : +65-6470-2308
Spain	Mitsubishi Electric Europe B.V. Spanish Branch Carretera de Rubi 76-80.AC.420, E-08190 Sant Cugat del Valles (Barcelona), Spain Tel : +34-93-565-3131	Thailand	Mitsubishi Electric Automation (Thailand) Co., Ltd. Bang-Chan Industrial Estate No.111 Soi Serithai 54, T.Kannayao, A.Kannayao, Bangkok 10230 Thailand Tel : +66-2906-3238
France	Mitsubishi Electric Europe B.V. French Branch 25, Boulevard des Bouvets, F-92741 Nanterre Cedex, France Tel : +33-1-5568-5568	Indonesia	P. T. Autoteknindo Sumber Makmur Muara Karang Selatan, Block A / Utara No.1 Kav. No. 11, Kawasan Industri Pergudangan, Jakarta-Utara 14440, P.O. Box 5045, Indonesia Tel : +62-21-663-0833
Czech Republic	Mitsubishi Electric Europe B.V.-o.s.Czech office Avenir Business Park, Radicka 751/113e, 158 00 Praha5, Czech Republic Tel : +420-251-551-470	India	Mitsubishi Electric India Pvt. Ltd. 2nd Floor, Tower A & B, Cyber Greens, DLF Cyber City, DLF Phase-III, Gurgaon-122002 Haryana, India Tel : +91-124-463-0300
Poland	Mitsubishi Electric Europe B.V. Polish Branch ul. Krakowska 50, 32-083 Balice, Poland Tel : +48-12-630-47-00	Australia	Mitsubishi Electric Australia Pty. Ltd. 348 Victoria Road PO BOX11, Rydalmere, N.S.W 2116, Australia Tel : +61-2-9684-7777
Russia	Mitsubishi Electric Europe B.V. Russian Branch St.Petersburg office Piskarevsky pr. 2, bld 2, lit "Sch", BC "Benua", office 720; 195027, St. Petersburg, Russia Tel : +7-812-633-3497		

## MITSUBISHI ELECTRIC CORPORATION

HEAD OFFICE : TOKYO BUILDING, 2-7-3 MARUNOUCHI, CHIYODA-KU, TOKYO 100-8310, JAPAN  
NAGOYA WORKS : 1-14, YADA-MINAMI 5-CHOME, HIGASHI-KU, NAGOYA, JAPAN

When exported from Japan, this manual does not require application to the Ministry of Economy, Trade and Industry for service transaction permission.

Specifications subject to change without notice.