



Mitsubishi Programmable Controller

MELSEC iQ-R
series

MELSEC iQ-R Digital-Analog Converter Module User's Manual (Startup)

-R60DA4
-R60DAV8
-R60DAI8

SAFETY PRECAUTIONS

(Read these precautions before using this product.)

Before using the MELSEC iQ-R series programmable controllers, please read the manuals of each product and the relevant manuals introduced in the manuals of each product carefully, and pay full attention to safety to handle the product correctly. In this manual, the safety precautions are classified into two levels: "⚠ WARNING" and "⚠ CAUTION".



WARNING

Indicates that incorrect handling may cause hazardous conditions, resulting in death or severe injury.



CAUTION

Indicates that incorrect handling may cause hazardous conditions, resulting in minor or moderate injury or property damage.

Under some circumstances, failure to observe the precautions given under "⚠ CAUTION" may lead to serious consequences.

Observe the precautions of both levels because they are important for personal and system safety.

Make sure that the end users read this manual and then keep the manual in a safe place for future reference.

[Design Precautions]

WARNING

- Configure safety circuits external to the programmable controller to ensure that the entire system operates safely even when a fault occurs in the external power supply or the programmable controller. Failure to do so may result in an accident due to an incorrect output or malfunction.
 - (1) Emergency stop circuits, protection circuits, and protective interlock circuits for conflicting operations (such as forward/reverse rotations or upper/lower limit positioning) must be configured external to the programmable controller.
 - (2) When the programmable controller detects an abnormal condition, it stops the operation and all outputs are:
 - Turned off if the overcurrent or overvoltage protection of the power supply module is activated.
 - Held or turned off according to the parameter setting if the self-diagnostic function of the CPU module detects an error such as a watchdog timer error.
 - (3) All outputs may be turned on if an error occurs in a part, such as an I/O control part, where the CPU module cannot detect any error. To ensure safety operation in such a case, provide a safety mechanism or a fail-safe circuit external to the programmable controller. For a fail-safe circuit example, refer to "General Safety Requirements" in the MELSEC iQ-R Module Configuration Manual.
 - (4) Outputs may remain on or off due to a failure of a component such as a relay and transistor in an output circuit. Configure an external circuit for monitoring output signals that could cause a serious accident.
 - In an output circuit, when a load current exceeding the rated current or an overcurrent caused by a load short-circuit flows for a long time, it may cause smoke and fire. To prevent this, configure an external safety circuit, such as a fuse.
 - Configure a circuit so that the programmable controller is turned on first and then the external power supply. If the external power supply is turned on first, an accident may occur due to an incorrect output or malfunction.
 - For the operating status of each station after a communication failure, refer to manuals relevant to the network. Incorrect output or malfunction due to a communication failure may result in an accident.
 - When connecting an external device with a CPU module or intelligent function module to modify data of a running programmable controller, configure an interlock circuit in the program to ensure that the entire system will always operate safely. For other forms of control (such as program modification, parameter change, forced output, or operating status change) of a running programmable controller, read the relevant manuals carefully and ensure that the operation is safe before proceeding. Improper operation may damage machines or cause accidents.
 - Especially, when a remote programmable controller is controlled by an external device, immediate action cannot be taken if a problem occurs in the programmable controller due to a communication failure. To prevent this, configure an interlock circuit in the program, and determine corrective actions to be taken between the external device and CPU module in case of a communication failure.
 - Do not write any data to the "system area" and "write-protect area" of the buffer memory in the module. Also, do not use any "use prohibited" signals as an output signal from the CPU module to each module. Doing so may cause malfunction of the programmable controller system. For the "system area", "write-protect area", and the "use prohibited" signals, refer to the user's manual for the module used.
-

[Design Precautions]

WARNING

- If a communication cable is disconnected, the network may be unstable, resulting in a communication failure of multiple stations. Configure an interlock circuit in the program to ensure that the entire system will always operate safely even if communications fail. Incorrect output or malfunction due to a communication failure may result in an accident.
- To maintain the safety of the programmable controller system against unauthorized access from external devices via the network, take appropriate measures. To maintain the safety against unauthorized access via the Internet, take measures such as installing a firewall.

[Precautions for using digital-analog converter modules]

- Outputs may remain on or off due to a failure of a transistor for external output. Configure an external circuit for monitoring output signals that could cause a serious accident.

[Precautions for using high-speed counter modules]

- Outputs may remain on or off due to a failure of a transistor for external output. Configure an external circuit for monitoring output signals that could cause a serious accident.

[Precautions for using positioning modules and simple motion modules]

- Configure safety circuits external to the programmable controller to ensure that the entire system operates safely even when a fault occurs in the external power supply or the programmable controller. Failure to do so may result in an accident due to an incorrect output or malfunction.
 - (1) Machine OPR (Original Point Return) is controlled by two kinds of data: an OPR direction and an OPR speed. Deceleration starts when the near-point dog signal turns on. If an incorrect OPR direction is set, motion control may continue without deceleration. To prevent machine damage caused by this, configure an interlock circuit external to the programmable controller.
 - (2) When the positioning module detects an error, the motion slows down and stops or the motion suddenly stops, depending on the stop group setting in parameter. Set the parameters to meet the specifications of the positioning control system used. In addition, set the OPR parameters and positioning data within the specified setting range.
 - (3) Outputs may remain on or off, or become undefined due to a failure of a component such as an insulation element and transistor in an output circuit, where the positioning module cannot detect any error. In a system where the incorrect outputs could cause a serious accident, configure an external circuit for monitoring output signals.
 - An absolute position restoration by the positioning function of the positioning module may turn off the servo-on signal (servo off) for approximately 60ms + scan time, and the motor may run unexpectedly. If this causes a problem, provide an electromagnetic brake to lock the motor during absolute position restoration.
-

[Design Precautions]

WARNING

[Precautions for using Motion CPUs and simple motion modules]

- If safety standards (such as robot safety rules) apply to the system using the module, servo amplifier, and servomotor, satisfy the safety standards.
- Construct a safety circuit externally of the module or servo amplifier if the abnormal operation of the module or servo amplifier differs from the safety directive operation in the system.

[Precautions for using CC-Link IE Controller Network (when optical fiber cables are used)]

- The optical transmitter and receiver of the CC-Link IE Controller Network module use laser diodes (class 1 in accordance with IEC 60825-1). Do not look directly at a laser beam. Doing so may harm your eyes.

[Precautions for using CC-Link system master/local modules]

- To set the refresh device with module parameters, select the device Y for the remote output (RY) refresh device. If a device other than Y, such as M and L, is selected, the CPU module holds the device status even after its status is changed to STOP. For how to stop data link, refer to the MELSEC iQ-R CC-Link System Master/Local Module User's Manual (Application).
-

[Design Precautions]

CAUTION

- Do not install the control lines or communication cables together with the main circuit lines or power cables. Keep a distance of 100mm or more between them. Failure to do so may result in malfunction due to noise.
- During control of an inductive load such as a lamp, heater, or solenoid valve, a large current (approximately ten times greater than normal) may flow when the output is turned from off to on. Therefore, use a module that has a sufficient current rating.
- After the CPU module is powered on or is reset, the time taken to enter the RUN status varies depending on the system configuration, parameter settings, and/or program size. Design circuits so that the entire system will always operate safely, regardless of the time.
- Do not power off the programmable controller or reset the CPU module while the setting values in the buffer memory are being written to the flash ROM in the module. Doing so will make the data in the flash ROM undefined. The values need to be set in the buffer memory and written to the flash ROM again. Doing so also can cause malfunction or failure of the module.
- When changing the operating status of the CPU module from external devices (such as the remote RUN/STOP functions), select "Do Not OPEN in Program" for "Open Method Setting" in the module parameters. If "OPEN in Program" is selected, an execution of the remote STOP function causes the communication line to close. Consequently, the CPU module cannot reopen the line, and external devices cannot execute the remote RUN function.

[Precautions for using digital-analog converter modules]

- Power on or off the external power supply while the programmable controller is on. Failure to do so may result in incorrect output or malfunction.
- When the power supply is turned on or off, the external power supply is turned on or off, or an output range is switched, a voltage may be applied or a current may flow from between output terminals for a moment. In this case, start the control after analog outputs become stable.

[Precautions for using high-speed counter modules]

- Do not install the control lines or communication cables together with the main circuit lines or power cables. Keep a distance of 150mm or more between them. Failure to do so may result in malfunction due to noise.
-

[Installation Precautions]

WARNING

- Shut off the external power supply (all phases) used in the system before mounting or removing the module. Failure to do so may result in electric shock or cause the module to fail or malfunction.
-

[Installation Precautions]

CAUTION

- Use the programmable controller in an environment that meets the general specifications in the Safety Guidelines included with the base unit. Failure to do so may result in electric shock, fire, malfunction, or damage to or deterioration of the product.
 - To mount a module, place the concave part(s) located at the bottom onto the guide(s) of the base unit, and push in the module until the hook(s) located at the top snaps into place. Incorrect interconnection may cause malfunction, failure, or drop of the module.
 - When using the programmable controller in an environment of frequent vibrations, fix the module with a screw.
 - Tighten the screws within the specified torque range. Undertightening can cause drop of the screw, short circuit, or malfunction. Overtightening can damage the screw and/or module, resulting in drop, short circuit, or malfunction.
 - When using an extension cable, connect it to the extension cable connector of the base unit securely. Check the connection for looseness. Poor contact may cause malfunction.
 - When using an SD memory card, fully insert it into the SD memory card slot. Check that it is inserted completely. Poor contact may cause malfunction. / Failure to do so may cause malfunction.
 - Securely insert an extended SRAM cassette into the cassette connector of the CPU module. After insertion, close the cassette cover and check that the cassette is inserted completely. Poor contact may cause malfunction.
 - Do not directly touch any conductive parts and electronic components of the module, SD memory card, extended SRAM cassette, or connector. Doing so can cause malfunction or failure of the module.
-

[Wiring Precautions]

WARNING

- Shut off the external power supply (all phases) used in the system before installation or wiring. Failure to do so may result in electric shock or cause the module to fail or malfunction.
 - After installation and wiring, attach the included terminal cover to the module before turning it on for operation. Failure to do so may result in electric shock.
-

[Wiring Precautions]

CAUTION

- Individually ground the FG and LG terminals of the programmable controller with a ground resistance of 100 ohms or less. Failure to do so may result in electric shock or malfunction.
 - Use applicable solderless terminals and tighten them within the specified torque range. If any spade solderless terminal is used, it may be disconnected when the terminal screw comes loose, resulting in failure.
 - Check the rated voltage and signal layout before wiring to the module, and connect the cables correctly. Connecting a power supply with a different voltage rating or incorrect wiring may cause fire or failure.
 - Connectors for external devices must be crimped or pressed with the tool specified by the manufacturer, or must be correctly soldered. Incomplete connections may cause short circuit, fire, or malfunction.
 - Securely connect the connector to the module. Poor contact may cause malfunction.
 - Do not install the control lines or communication cables together with the main circuit lines or power cables. Keep a distance of 100mm or more between them. Failure to do so may result in malfunction due to noise.
 - Place the cables in a duct or clamp them. If not, dangling cable may swing or inadvertently be pulled, resulting in damage to the module or cables or malfunction due to poor contact. Do not clamp the extension cables with the jacket stripped.
 - Check the interface type and correctly connect the cable. Incorrect wiring (connecting the cable to an incorrect interface) may cause failure of the module and external device.
 - Tighten the terminal screws or connector screws within the specified torque range. Undertightening can cause drop of the screw, short circuit, fire, or malfunction. Overtightening can damage the screw and/or module, resulting in drop, short circuit, fire, or malfunction.
 - When disconnecting the cable from the module, do not pull the cable by the cable part. For the cable with connector, hold the connector part of the cable. For the cable connected to the terminal block, loosen the terminal screw. Pulling the cable connected to the module may result in malfunction or damage to the module or cable.
 - Prevent foreign matter such as dust or wire chips from entering the module. Such foreign matter can cause a fire, failure, or malfunction.
 - A protective film is attached to the top of the module to prevent foreign matter, such as wire chips, from entering the module during wiring. Do not remove the film during wiring. Remove it for heat dissipation before system operation.
 - Mitsubishi programmable controllers must be installed in control panels. Connect the main power supply to the power supply module in the control panel through a relay terminal block. Wiring and replacement of a power supply module must be performed by qualified maintenance personnel with knowledge of protection against electric shock. For wiring, refer to the MELSEC iQ-R Module Configuration Manual.
 - For Ethernet cables to be used in the system, select the ones that meet the specifications in the user's manual for each module. If not, normal data transmission is not guaranteed.
-

[Wiring Precautions]

CAUTION

[Precautions for using high-speed counter modules]

- Do not install the control lines or communication cables together with the main circuit lines or power cables. Keep a distance of 150mm or more between them. Failure to do so may result in malfunction due to noise.
- Ground the shield cable on the encoder side (relay box) with a ground resistance of 100 ohm or less. Failure to do so may cause malfunction.

[Precautions for using CC-Link IE Controller Network (when optical fiber cables are used)]

- For optical fiber cables to be used in the system, select the ones that meet the specifications in the MELSEC iQ-R Ethernet/CC-Link IE User's Manual (Startup). If not, normal data transmission is not guaranteed.

[Precautions for using CC-Link system master/local modules]

- For the CC-Link system, use a Ver.1.10-compatible CC-Link dedicated cable. If not, the performance of the CC-Link system is not guaranteed. The station-to-station distance and maximum station-to-station distance must meet the specifications in the MELSEC iQ-R CC-Link System Master/Local Module User's Manual (Startup). If not, normal data transmission is not guaranteed.
-

[Startup and Maintenance Precautions]

Warning

- Do not touch any terminal while power is on. Doing so will cause electric shock or malfunction.
 - Correctly connect the battery connector. Do not charge, disassemble, heat, short-circuit, solder, or throw the battery into the fire. Also, do not expose it to liquid or strong shock. Doing so will cause the battery to produce heat, explode, ignite, or leak, resulting in injury and fire.
 - Shut off the external power supply (all phases) used in the system before cleaning the module or retightening the terminal screws, connector screws, or module fixing screws. Failure to do so may result in electric shock.
-

[Startup and Maintenance Precautions]

CAUTION

- When connecting an external device with a CPU module or intelligent function module to modify data of a running programmable controller, configure an interlock circuit in the program to ensure that the entire system will always operate safely. For other forms of control (such as program modification, parameter change, forced output, or operating status change) of a running programmable controller, read the relevant manuals carefully and ensure that the operation is safe before proceeding. Improper operation may damage machines or cause accidents.
 - Especially, when a remote programmable controller is controlled by an external device, immediate action cannot be taken if a problem occurs in the programmable controller due to a communication failure. To prevent this, configure an interlock circuit in the program, and determine corrective actions to be taken between the external device and CPU module in case of a communication failure.
 - Do not disassemble or modify the modules. Doing so may cause failure, malfunction, injury, or a fire.
 - Use any radio communication device such as a cellular phone or PHS (Personal Handy-phone System) more than 25cm away in all directions from the programmable controller. Failure to do so may cause malfunction.
 - Shut off the external power supply (all phases) used in the system before mounting or removing the module. Failure to do so may cause the module to fail or malfunction.
 - Tighten the screws within the specified torque range. Undertightening can cause drop of the component or wire, short circuit, or malfunction. Overtightening can damage the screw and/or module, resulting in drop, short circuit, or malfunction.
 - After the first use of the product, do not mount/remove the module to/from the base unit, and the terminal block to/from the module, and do not insert/remove the extended SRAM cassette to/from the CPU module more than 50 times (IEC 61131-2 compliant) respectively. Exceeding the limit may cause malfunction.
 - After the first use of the product, do not insert/remove the SD memory card to/from the CPU module more than 500 times. Exceeding the limit may cause malfunction.
 - Do not touch the metal terminals on the back side of the SD memory card. Doing so may cause malfunction.
 - Do not touch the integrated circuits on the circuit board of an extended SRAM cassette. Doing so may cause malfunction.
 - Do not drop or apply shock to the battery to be installed in the module. Doing so may damage the battery, causing the battery fluid to leak inside the battery. If the battery is dropped or any shock is applied to it, dispose of it without using.
 - Startup and maintenance of a control panel must be performed by qualified maintenance personnel with knowledge of protection against electric shock. Lock the control panel so that only qualified maintenance personnel can operate it.
 - Before handling the module, touch a conducting object such as a grounded metal to discharge the static electricity from the human body. Failure to do so may cause the module to fail or malfunction.
-

[Startup and Maintenance Precautions]

CAUTION

[Precautions for using positioning modules, Motion CPUs, and simple motion modules]

- Before testing the operation, set a low speed value for the speed limit parameter so that the operation can be stopped immediately upon occurrence of a hazardous condition.
- Check and adjust the programs and each parameter before the operation. Some machines may operate in an unexpected way.

[Precautions for using Motion CPUs and simple motion modules]

- When a system is newly started, or a module or an absolute value-compatible motor is replaced while the absolute position system function is used, always perform the OPR.
 - Operate the modules after checking the brake function.
 - Do not conduct a megger test (an insulation resistance measurement) during an inspection.
 - When maintenance and inspection are completed, check whether the absolute position detection function correctly detects the position.
 - Lock the control panel so that only qualified personnel with knowledge of electrical equipment can operate it.
-

[Operating Precautions]

CAUTION

- When changing data and operating status, and modifying program of the running programmable controller from an external device such as a personal computer connected to an intelligent function module, read relevant manuals carefully and ensure the safety before operation. Incorrect change or modification may cause system malfunction, damage to the machines, or accidents.
- Do not power off the programmable controller or reset the CPU module while the setting values in the buffer memory are being written to the flash ROM in the module. Doing so will make the data in the flash ROM undefined. The values need to be set in the buffer memory and written to the flash ROM again. Doing so also can cause malfunction or failure of the module.

[Precautions for using positioning modules, Motion CPUs, and simple motion modules]

- Note that when the reference axis speed is specified for interpolation operation, the speed of the partner axis (2nd, 3rd, or 4th axis) may exceed the speed limit value.
 - Stay away from the machine during the operation such as test operation and teaching. Failure to do so may cause an injury.
-

[Disposal Precautions]

CAUTION

- When disposing of this product, treat it as industrial waste.
 - When disposing of batteries, separate them from other wastes according to the local regulations. For details on battery regulations in EU member states, refer to the MELSEC iQ-R Module Configuration Manual.
-

[Transportation Precautions]

CAUTION

- When transporting lithium batteries, follow the transportation regulations. For details on the regulated models, refer to the MELSEC iQ-R Module Configuration Manual.
 - The halogens (such as fluorine, chlorine, bromine, and iodine), which are contained in a fumigant used for disinfection and pest control of wood packaging materials, may cause failure of the product. Prevent the entry of fumigant residues into the product or consider other methods (such as heat treatment) instead of fumigation. The disinfection and pest control measures must be applied to unprocessed raw wood.
-

CONDITIONS OF USE FOR THE PRODUCT

- (1) Mitsubishi programmable controller ("the PRODUCT") shall be used in conditions;
- i) where any problem, fault or failure occurring in the PRODUCT, if any, shall not lead to any major or serious accident; and
 - ii) where the backup and fail-safe function are systematically or automatically provided outside of the PRODUCT for the case of any problem, fault or failure occurring in the PRODUCT.
- (2) The PRODUCT has been designed and manufactured for the purpose of being used in general industries. MITSUBISHI SHALL HAVE NO RESPONSIBILITY OR LIABILITY (INCLUDING, BUT NOT LIMITED TO ANY AND ALL RESPONSIBILITY OR LIABILITY BASED ON CONTRACT, WARRANTY, TORT, PRODUCT LIABILITY) FOR ANY INJURY OR DEATH TO PERSONS OR LOSS OR DAMAGE TO PROPERTY CAUSED BY the PRODUCT THAT ARE OPERATED OR USED IN APPLICATION NOT INTENDED OR EXCLUDED BY INSTRUCTIONS, PRECAUTIONS, OR WARNING CONTAINED IN MITSUBISHI'S USER, INSTRUCTION AND/OR SAFETY MANUALS, TECHNICAL BULLETINS AND GUIDELINES FOR the PRODUCT.

("Prohibited Application")

Prohibited Applications include, but not limited to, the use of the PRODUCT in;

- Nuclear Power Plants and any other power plants operated by Power companies, and/or any other cases in which the public could be affected if any problem or fault occurs in the PRODUCT.
- Railway companies or Public service purposes, and/or any other cases in which establishment of a special quality assurance system is required by the Purchaser or End User.
- Aircraft or Aerospace, Medical applications, Train equipment, transport equipment such as Elevator and Escalator, Incineration and Fuel devices, Vehicles, Manned transportation, Equipment for Recreation and Amusement, and Safety devices, handling of Nuclear or Hazardous Materials or Chemicals, Mining and Drilling, and/or other applications where there is a significant risk of injury to the public or property.

Notwithstanding the above, restrictions Mitsubishi may in its sole discretion, authorize use of the PRODUCT in one or more of the Prohibited Applications, provided that the usage of the PRODUCT is limited only for the specific applications agreed to by Mitsubishi and provided further that no special quality assurance or fail-safe, redundant or other safety features which exceed the general specifications of the PRODUCTS are required. For details, please contact the Mitsubishi representative in your region.

INTRODUCTION

Thank you for purchasing the Mitsubishi MELSEC iQ-R series programmable controllers.

This manual describes the performance specifications, procedures before operation, wiring, and operation example of the following relevant modules.

Before using this product, please read this manual and the relevant manuals carefully and develop familiarity with the functions and performance of the MELSEC iQ-R series programmable controller to handle the product correctly.

When applying the program examples introduced in this manual to an actual system, ensure the applicability and confirm that it will not cause system control problems.

Please make sure that the end users read this manual.

Point

Unless otherwise specified, this manual describes the program examples in which the I/O numbers of X/Y0 to X/YF are assigned for a D/A converter module. I/O numbers must be assigned to apply the program examples introduced in this manual to an actual system. For I/O number assignment, refer to the following.

 MELSEC iQ-R Module Configuration Manual



Relevant modules

R60DA4, R60DAV8, R60DAI8

COMPLIANCE WITH EMC AND LOW VOLTAGE DIRECTIVES

Method of ensuring compliance

To ensure that Mitsubishi programmable controllers maintain EMC and Low Voltage Directives when incorporated into other machinery or equipment, certain measures may be necessary. Please refer to one of the following manuals.

-  MELSEC iQ-R Module Configuration Manual
-  Safety Guidelines (This manual is included with the base unit.)

The CE mark on the side of the programmable controller indicates compliance with EMC and Low Voltage Directives.

Additional measures

No additional measures are necessary for the compliance of this product with EMC and Low Voltage Directives.

MEMO

CONTENTS

SAFETY PRECAUTIONS	1
CONDITIONS OF USE FOR THE PRODUCT	12
INTRODUCTION	12
COMPLIANCE WITH EMC AND LOW VOLTAGE DIRECTIVES	13
RELEVANT MANUALS	16
TERMS	16
CHAPTER 1 PART NAMES	18
CHAPTER 2 SPECIFICATIONS	20
2.1 Performance Specifications	20
CHAPTER 3 FUNCTION LIST	23
CHAPTER 4 PROCEDURES BEFORE OPERATION	25
CHAPTER 5 WIRING	27
5.1 Terminal Block	27
5.2 External Wiring	29
CHAPTER 6 OPERATION EXAMPLE	32
6.1 Programming Procedure	32
6.2 Program Examples	32
CHAPTER 7 OFFSET/GAIN SETTING	38
7.1 Setting Procedure	38
APPENDICES	41
Appendix 1 I/O Conversion Characteristics	41
Appendix 2 Accuracy	44
Appendix 3 External Dimensions	45
INDEX	48
REVISIONS	50
WARRANTY	51
TRADEMARKS	52

RELEVANT MANUALS

Manual name [manual number]	Description	Available form
MELSEC iQ-R Digital-Analog Converter Module User's Manual (Startup) [SH-081235] (this manual)	Specifications, procedures before operation, wiring, operation example, and offset/gain setting of the D/A converter module	Print book e-Manual EPUB PDF
MELSEC iQ-R Digital-Analog Converter Module User's Manual (Application) [SH-081237]	Functions, parameter setting, troubleshooting, I/O signals, and buffer memory areas of the D/A converter module	Print book e-Manual EPUB PDF

This manual does not describe the details of the following.

- General specifications
- Available CPU modules and the number of mountable modules
- Installation

For details, refer to the following.

 MELSEC iQ-R Module Configuration Manual

This manual does not describe the module function block.

For details on the module function block, refer to the function block reference for the module used.

Point

e-Manuals are electronic book-type manuals for Mitsubishi Electric FA products that can be read with a dedicated tool.

The following shows the features of e-Manuals.

- Desired information can be searched for from multiple manuals at a time. (Manual cross search)
- Other manuals can be referred to from links in a manual.
- Desired hardware specifications can be checked from each part in the illustrations of products.
- Information frequently referred to can be registered as a favorite.

TERMS

Unless otherwise specified, this manual uses the following terms.

Term	Description
D/A converter module	The abbreviation for the MELSEC iQ-R series digital-analog converter module
GX Works3	The product name of the software package for the MELSEC programmable controllers
Watchdog timer error	An error that occurs if the internal processing of the D/A converter module is abnormal. Watchdog timer enables the module to monitor its own internal processing.
Engineering tool	A generic term for GX Works3
Normal mode	Setting values of the operation mode setting: normal mode and offset/gain setting mode
Offset/gain setting mode	
Buffer memory	A memory in an intelligent function module, where data (such as setting values and monitoring values) exchanged with a CPU module are stored
User range	An analog output range where any value can be set. Set the user range in the offset/gain setting.
R mode	A mode that the module operates with the buffer memory map that memory areas have been newly laid out in the MELSEC iQ-R series.
Q compatible mode	A mode that the module operates with the buffer memory map converted to the equivalent map of the MELSEC-Q series.
Global label	A label that is valid for all program data created in the project. The global label has two types: a module specific label (module label) generated automatically by GX Works3, and an optional label for which any device can be specified.
Module label	A label that represents a memory (I/O signals and buffer memory areas) specific to each module in a given character string. Through the module used, GX Works3 automatically generates this label, which can be used as a global label.

MEMO

1 PART NAMES

The following describes the part names of the D/A converter module.

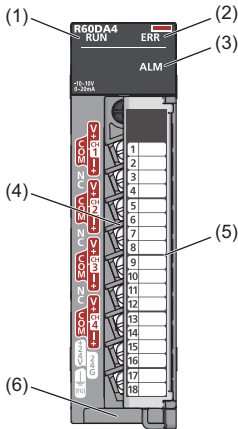

No.	Name	Description
(1)	RUN LED	Indicates the operating status of the module. On: Normal operation Flashing (1s cycles): In offset/gain setting mode Flashing (400ms cycles): Selected as a module for the online module change Off: 5V power supply interrupted, watchdog timer error occurred, or module replacement allowed in the process of the online module change
(2)	ERR LED	Indicates the error status of the module.*1 On: Error occurred Off: Normal operation
(3)	ALM LED	Indicates the alarm status of the module.*1 On: Alert output occurred Off: Normal operation
(4)	Terminal block	18-point screw terminal block for connecting output signal wires of external devices and others
(5)	Terminal block cover	Covers for preventing electric shock while the power is on
(6)	Production information display	Displays the production information (16 digits) of the module.

*1 For details, refer to the following.

📖 MELSEC iQ-R Digital-Analog Converter Module User's Manual (Application)

2 SPECIFICATIONS

This chapter describes the performance specifications.

2.1 Performance Specifications

This section describes the performance specifications of the D/A converter modules.

R60DA4					
Item		Specifications			
Number of analog output points		4 points (4 channels)			
Digital input		16-bit signed binary value (-32768 to 32767)			
Analog output voltage		-10 to 10VDC (external load resistance value 1kΩ or more) 0 to 5VDC (external load resistance value 500Ω or more)			
Analog output current		0 to 20mADC (external load resistance value 0 to 600Ω)			
I/O characteristics, resolution ^{*1}		Analog output range			
		Voltage	0 to 5V	0 to 32000	156.3μV
			1 to 5V		
			-10 to 10V	-32000 to 32000	312.5μV
			User range setting (voltage)		
		Current	0 to 20mA	0 to 32000	625.0nA
			4 to 20mA		
User range setting (current)	-32000 to 32000		350.9nA		
Accuracy (accuracy for the maximum value of the analog output value) ^{*2}		Ambient temperature 25 ±5°C: Within ±0.1% (Voltage ±10mV, current ±20μA) Ambient temperature 0 to 55°C: Within ±0.3% (Voltage ±30mV, current ±60μA)			
Conversion speed	Normal output mode	80μs/CH			
	Wave output mode	80μs/CH			
Number of offset/gain settings ^{*3}		Up to 50000 times			
Output short protection		Protected			
Isolation method		Between I/O terminals and programmable controller power supply: Photocoupler Between output channels: Non-isolation Between the external power supply and analog outputs: Transformer isolation			
Withstand voltage		Between I/O terminals and programmable controller power supply: 500VACrms for 1 minute Between the external power supply and analog outputs: 500VACrms for 1 minute			
Insulation resistance		Between I/O terminals and programmable controller power supply: 10MΩ or higher, at 500VDC			
Number of occupied I/O points		16 points (I/O assignment: Intelligent 16 points)			
External connection system		18-point terminal block			
Applicable wire size		0.3 to 0.75mm ²			
Applicable solderless terminal		R1.25-3 (solderless terminal with an insulation sleeve cannot be used)			
External power supply		24VDC +20%, -15%			
		Ripple, spike 500mV _{p-p} or lower			
		Inrush current: 5.0A, 690μs or shorter			
		Current consumption: 0.14A			
Internal current consumption (5VDC)		0.16A			
External dimensions	Height	106mm (Base unit mounting side: 98mm)			
	Width	27.8mm			
	Depth	131mm			
Weight		0.14kg			

*1 For details on the I/O conversion characteristic, refer to the following.

 Page 41 I/O Conversion Characteristics

*2 Except for the conditions under noise influence.

*3 A count more than 50000 times causes Number of writes to offset/gain settings reach limit error (error code: 1080H).

R60DAV8

Item	Specifications		
Number of analog output points	8 points (8 channels)		
Digital input	16-bit signed binary value (-32768 to 32767)		
Analog output voltage	-10 to 10VDC (external load resistance value 1kΩ or more) 0 to 5VDC (external load resistance value 500Ω or more)		
Analog output current	—		
I/O characteristics, resolution ^{*1}	Analog output range		Digital value
	Voltage	0 to 5V	0 to 32000
		1 to 5V	
		-10 to 10V	-32000 to 32000
User range setting (voltage)		312.5μV	
Accuracy (accuracy for the maximum value of the analog output value) ^{*2}	Ambient temperature 25 ±5°C: Within ±0.1% (Voltage ±10mV) Ambient temperature 0 to 55°C: Within ±0.3% (Voltage ±30mV)		
Conversion speed	80μs/CH		
Number of offset/gain settings ^{*3}	Up to 50000 times		
Output short protection	Protected		
Isolation method	Between I/O terminals and programmable controller power supply: Photocoupler Between output channels: Non-isolation Between the external power supply and analog outputs: Transformer isolation		
Withstand voltage	Between I/O terminals and programmable controller power supply: 500VACrms for 1 minute Between the external power supply and analog outputs: 500VACrms for 1 minute		
Insulation resistance	Between I/O terminals and programmable controller power supply: 10MΩ or higher, at 500VDC		
Number of occupied I/O points	16 points (I/O assignment: Intelligent 16 points)		
External connection system	18-point terminal block		
Applicable wire size	0.3 to 0.75mm ²		
Applicable solderless terminal	R1.25-3 (solderless terminal with an insulation sleeve cannot be used)		
External power supply	24VDC +20%, -15%		
	Ripple, spike 500mV _{P-P} or lower		
	Inrush current: 5.0A, 670μs or shorter		
	Current consumption: 0.16A		
Internal current consumption (5VDC)	0.16A		
External dimensions	Height	106mm (Base unit mounting side: 98mm)	
	Width	27.8mm	
	Depth	131mm	
Weight	0.14kg		

*1 For details on the I/O conversion characteristic, refer to the following.

 Page 41 I/O Conversion Characteristics

*2 Except for the conditions under noise influence.

*3 A count more than 50000 times causes Number of writes to offset/gain settings reach limit error (error code: 1080H).

R60DAI8

Item	Specifications		
Number of analog output points	8 points (8 channels)		
Digital input	16-bit signed binary value (-32768 to 32767)		
Analog output voltage	—		
Analog output current	0 to 20mADC (external load resistance value 0 to 600Ω)		
I/O characteristics, resolution*1	Analog output range		Digital value
	Current	0 to 20mA	0 to 32000
		4 to 20mA	
	User range setting (current)		-32000 to 32000
		350.9nA	
Accuracy (accuracy for the maximum value of the analog output value)*2	Ambient temperature 25±5°C: Within ±0.1% (Current ±20μA) Ambient temperature 0 to 55°C: Within ±0.3% (Current ±60μA)		
Conversion speed	80μs/CH		
Number of offset/gain settings*3	Up to 50000 times		
Output short protection	Protected		
Isolation method	Between I/O terminals and programmable controller power supply: Photocoupler Between output channels: Non-isolation Between the external power supply and analog outputs: Transformer isolation		
Withstand voltage	Between I/O terminals and programmable controller power supply: 500VACrms for 1 minute Between the external power supply and analog outputs: 500VACrms for 1 minute		
Insulation resistance	Between I/O terminals and programmable controller power supply: 10MΩ or higher, at 500VDC		
Number of occupied I/O points	16 points (I/O assignment: Intelligent 16 points)		
External connection system	18-point terminal block		
Applicable wire size	0.3 to 0.75mm ²		
Applicable solderless terminal	R1.25-3 (solderless terminal with an insulation sleeve cannot be used)		
External power supply	24VDC +20%, -15%		
	Ripple, spike 500mV _{p-p} or lower		
	Inrush current: 5.0A, 700μs or shorter		
	Current consumption: 0.26A		
Internal current consumption (5VDC)	0.16A		
External dimensions	Height	106mm (Base unit mounting side: 98mm)	
	Width	27.8mm	
	Depth	131mm	
Weight	0.14kg		

*1 For details on the I/O conversion characteristic, refer to the following.

 Page 41 I/O Conversion Characteristics

*2 Except for the conditions under noise influence.

*3 A count more than 50000 times causes Number of writes to offset/gain settings reach limit error (error code: 1080H).

3 FUNCTION LIST

The following table lists the functions of the D/A converter module. For further details on the function, refer to the following.
 MELSEC iQ-R Digital-Analog Converter Module User's Manual (Application)

Item	Description
Range switching function	Switches the output range of the analog outputs for each channel. Switching the range makes it possible to change the output conversion characteristics.
D/A conversion enable/disable setting function	Controls whether to enable or disable the D/A conversion for each channel. Disabling the D/A conversion on unused channels reduces the D/A conversion cycles.
D/A output enable/disable setting function	Specifies whether to output the D/A conversion value or offset value for each channel. The conversion speed is a constant, regardless of the output enable/disable status.
Analog output HOLD/CLEAR function	Sets whether to hold or clear the analog output value output when the operating status of the CPU module is RUN, STOP, or stop error.
Analog output test function when the CPU module is in the STOP status	Analog output tests can be carried out when the CPU module is in the STOP status.
Scaling function	Performs scale conversion on digital values within a specified range between a scaling upper limit value and a scaling lower limit value. The program for scale conversion can be omitted.
Shift function	Adds a set input value shift amount to a digital value.
Alert output function	Outputs an alert when the digital value exceeds the alert output upper limit value or becomes less than the alert output lower limit value.
Rate control function	Restricts the increasing/decreasing amount of the analog output value per 80μs and prevents a sudden change of the value.
Interruption of external power supply detection function	Detects that the external power supply 24VDC is not supplied or is shut off.
Disconnection detection function ^{*1}	Monitors the analog output value and detects a disconnection.
Interrupt function	Executes an interrupt program of the CPU module when an interrupt factor such as a disconnection or an alert output is detected.
Wave output function	Registers the prepared wave data (digital input value) to the D/A converter module and continuously outputs the data (analog value) in the set conversion cycle.
Inter-module synchronization function	Outputs the D/A conversion values simultaneously from multiple modules in which the inter-module synchronization function is active.
Error history function	Records up to the 16 errors and alarms that occurred in the D/A converter module to store them into the buffer memory area.
Event history function	Collects occurred errors and alarms, and performed operations in the D/A converter module as event information into the CPU module.
Offset/gain setting	Corrects errors in D/A conversion values for each channel.
Backing up, saving, and restoring offset/gain values	Makes it possible to back up, save, and restore the offset/gain values of the user range setting.
Online module change	Allows module replacement without stopping the system. For the procedure of the online module change, refer to the following.  MELSEC iQ-R Online Module Change Manual
Q compatible mode function	Controls an operation state with the buffer memory layout converted to equivalent one of the Q series. This compatibility makes it possible to reuse sequence programs that have exhibited high performance on the Q series analog output modules.

*1 This function is supported only by the R60DA4 and R60DAI8.

MEMO

4 PROCEDURES BEFORE OPERATION

This chapter describes the procedures before operation.

1. Mounting a module

Mount the D/A converter module in any desired configuration.

2. Wiring

Perform wiring of external devices to the D/A converter module.

 Page 29 External Wiring

3. Adding a module

Add the D/A converter module to a module configuration by using the engineering tool. For details, refer to the following.

 GX Works3 Operating Manual

4. Module setting

Perform the module initial setting, module label setting, and auto refresh setting by using an engineering tool. For details, refer to the following.

 MELSEC iQ-R Digital-Analog Converter Module User's Manual (Application)

5. Offset/gain setting

Perform the offset/gain setting to use a user range setting, if necessary.

 Page 38 OFFSET/GAIN SETTING

6. Programming

Create a program. For details, refer to the following.

 Page 32 OPERATION EXAMPLE

MEMO

5 WIRING

This chapter describes the wiring of the D/A converter module.

5.1 Terminal Block

Precautions

Tighten the module fixing screws and others within the specified torque range.

Screw type	Tightening torque range
Module fixing screw (M3) ^{*1}	0.37 to 0.48N·m
Terminal screw (M3)	0.42 to 0.58N·m
Terminal block mounting screw (M3.5)	0.66 to 0.89N·m

*1 The hook on the top of the module allows the module to be fixed to a base unit easily. In a place where there is a lot of vibration, however, fixing with module fixing screws is recommended.

The following table lists an applicable solderless terminal to be connected to the terminal block. When wiring, use applicable wires and an appropriate tightening torque. Use UL listed solderless terminals and, for processing, use a tool recommended by their manufacturer. Note that a solderless terminal with an insulation sleeve cannot be used.

Solderless terminal		Wire			
Model	Applicable tightening torque	Diameter	Type	Material	Temperature rating
R1.25-3	0.42 to 0.58N·m	0.3 to 0.75mm ² (22 to 18 AWG)	Stranded	Copper	75°C or greater

Signal names of the terminal blocks

The following table shows signal names of the terminal blocks.

■R60DA4

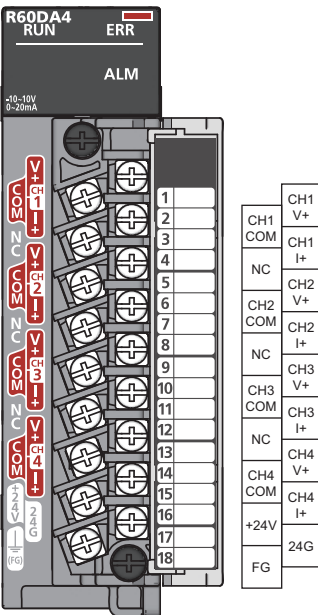
Terminal block	Terminal number	Signal name
	1	CH1 V+
	2	CH1 COM
	3	CH1 I+
	4	NC
	5	CH2 V+
	6	CH2 COM
	7	CH2 I+
	8	NC
	9	CH3 V+
	10	CH3 COM
	11	CH3 I+
	12	NC
	13	CH4 V+
	14	CH4 COM
	15	CH4 I+
	16	+24V
	17	24G
	18	FG

■R60DAV8

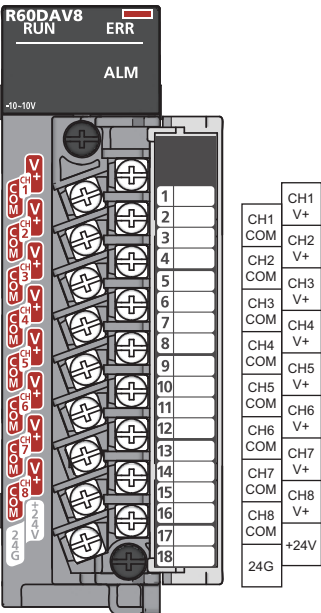
Terminal block	Terminal number	Signal name
 <p>R60DAV8 RUN ERR ALM -10~10V</p> <p>Terminal block diagram showing 18 terminals. The top row has indicators for RUN, ERR, and ALM. The bottom row has a -10~10V indicator. The terminal block is labeled with terminal numbers 1 through 18. A legend to the right of the terminal block lists the signal names for each terminal: CH1 V+, CH2 V+, CH3 V+, CH4 V+, CH5 V+, CH6 V+, CH7 V+, CH8 V+, +24V, and 24G.</p>	1	CH1 V+
	2	COM
	3	CH2 V+
	4	COM
	5	CH3 V+
	6	COM
	7	CH4 V+
	8	COM
	9	CH5 V+
	10	COM
	11	CH6 V+
	12	COM
	13	CH7 V+
	14	COM
	15	CH8 V+
	16	COM
	17	+24V
	18	24G

■R60DAI8

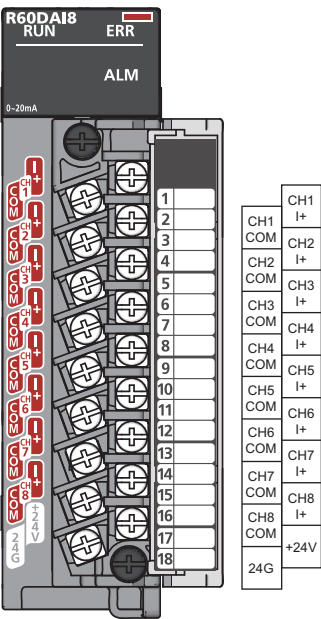
Terminal block	Terminal number	Signal name
 <p>R60DAI8 RUN ERR ALM 0~20mA</p> <p>Terminal block diagram showing 18 terminals. The top row has indicators for RUN, ERR, and ALM. The bottom row has a 0~20mA indicator. The terminal block is labeled with terminal numbers 1 through 18. A legend to the right of the terminal block lists the signal names for each terminal: CH1 I+, CH2 I+, CH3 I+, CH4 I+, CH5 I+, CH6 I+, CH7 I+, CH8 I+, +24V, and 24G.</p>	1	CH1 I+
	2	COM
	3	CH2 I+
	4	COM
	5	CH3 I+
	6	COM
	7	CH4 I+
	8	COM
	9	CH5 I+
	10	COM
	11	CH6 I+
	12	COM
	13	CH7 I+
	14	COM
	15	CH8 I+
	16	COM
	17	+24V
	18	24G

Point

Terminal blocks that have been used on MELSEC-Q series D/A converter modules can be used just the way they are. The terminal layout is the same as the MELSEC-Q series D/A converter modules (Q64DAN, Q68DAVN, and Q68DAIN).

The terminal blocks for MELSEC-L series D/A converter modules, however, cannot be used because of the shape difference.

5.2 External Wiring

Wiring to the terminal block

The following figures show wiring to the terminal block.

■R60DA4

For voltage output

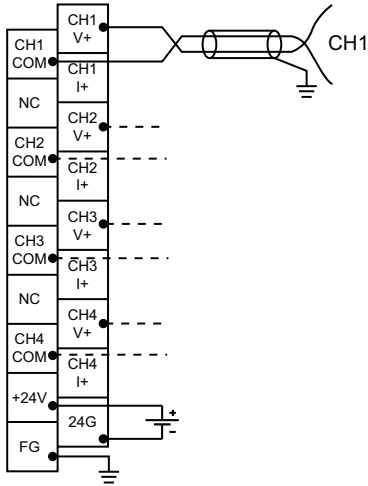

For current output

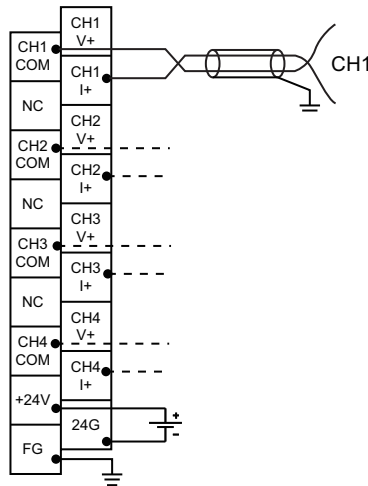

■R60DAV8

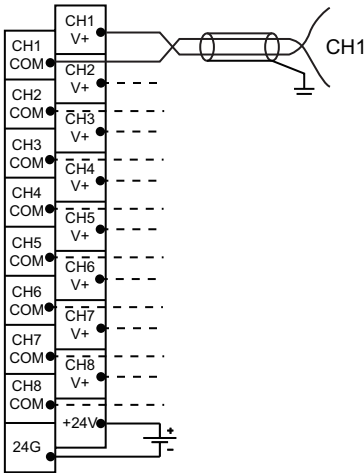

■R60DAI8

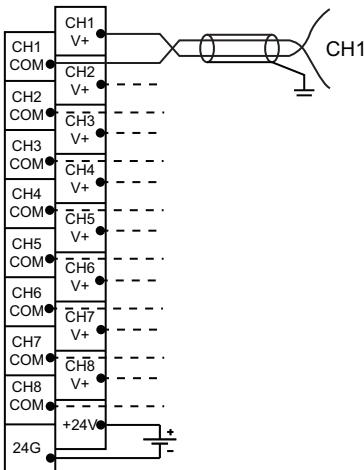

External wiring example

The following figures show the examples of external wiring.

■R60DA4

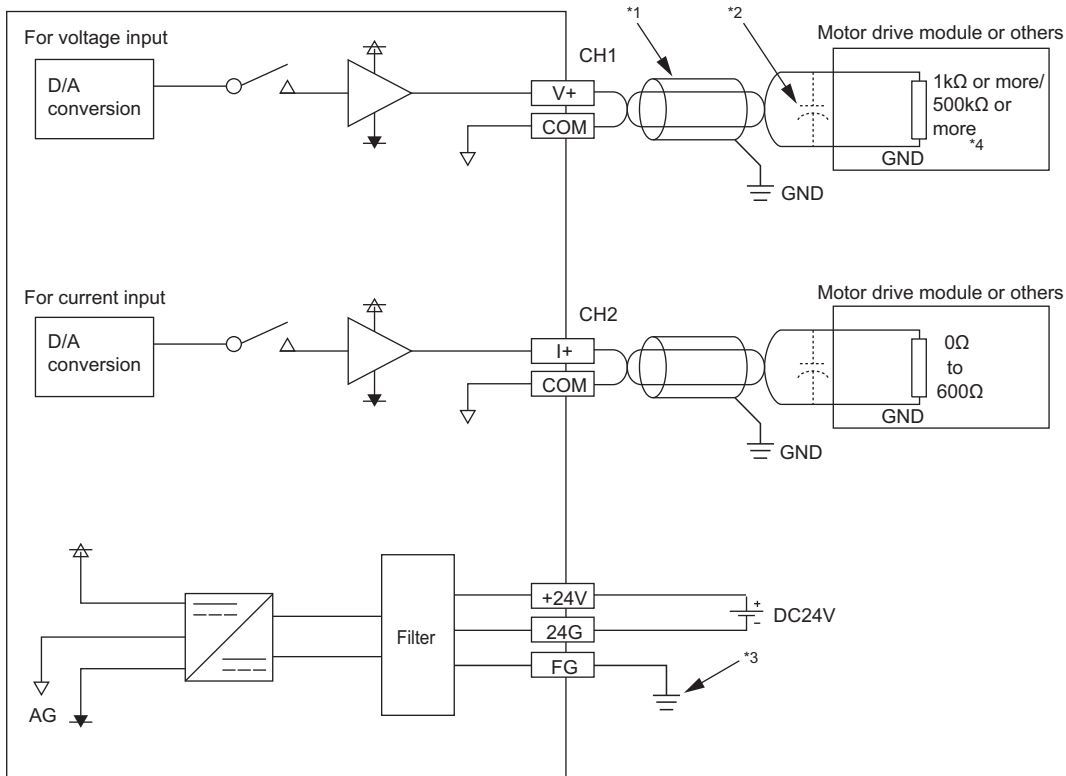

*1 For the wire, use the 2-core twisted cable.

*2 If noise or ripple occurs for analog signals, connect a capacitor with the value of 0.1 to 0.47 μ F (withstand voltage 25V or higher) to the input terminal of an external device.

*3 Always ground the FG terminal.

*4 When the analog output range is 0 to 5V, the external load resistance value should be 500 Ω or more.
When the analog output range is -10 to 10V, the external load resistance value should be 1k Ω or more.

■R60DAV8

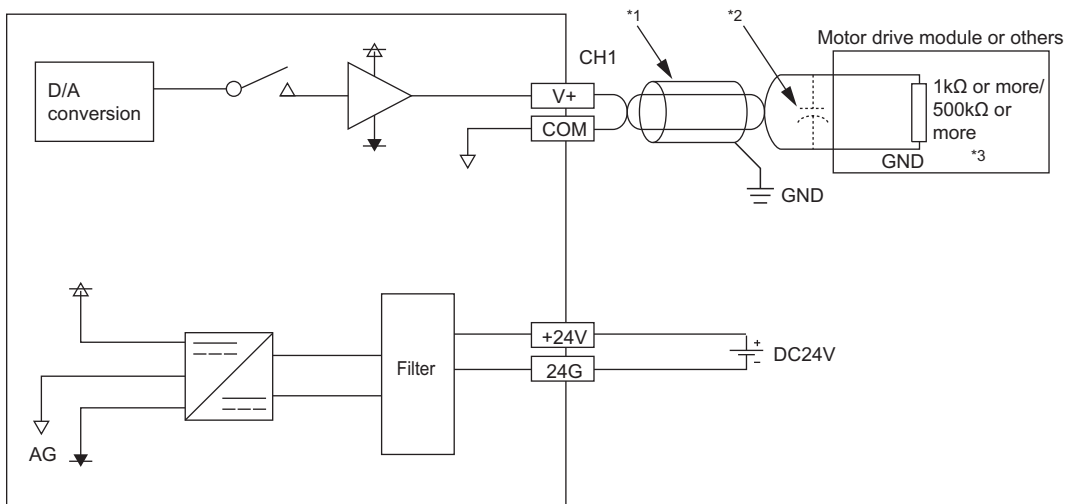

*1 For the wire, use the 2-core twisted cable.

*2 If noise or ripple occurs for analog signals, connect a capacitor with the value of 0.1 to 0.47 μ F (withstand voltage 25V or higher) to the input terminal of an external device.

*3 When the analog output range is 0 to 5V, the external load resistance value should be 500 Ω or more.
When the analog output range is -10 to 10V, the external load resistance value should be 1k Ω or more.

■R60DAI8

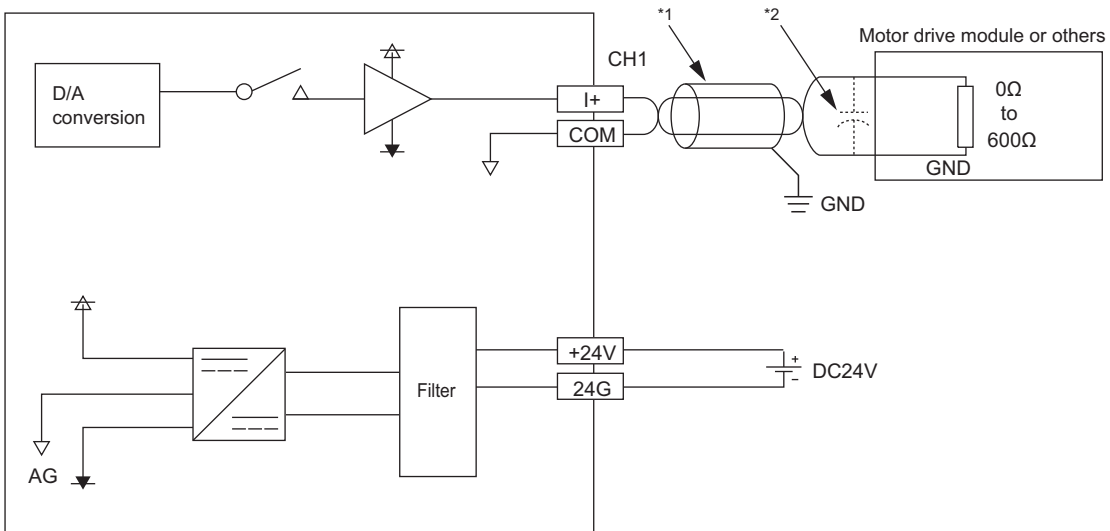

*1 For the wire, use the 2-core twisted cable.

*2 If noise or ripple occurs for analog signals, connect a capacitor with the value of 0.1 to 0.47 μ F (withstand voltage 25V or higher) to the input terminal of an external device.

Point

Ground the FG terminal of the power supply module.

6 OPERATION EXAMPLE

This chapter describes the programming procedure and the basic program of the D/A converter module.

6.1 Programming Procedure

Take the following steps to create a program for performing the D/A conversion:

1. Set parameters.

☞ Page 33 Parameter setting

2. Create a program.

☞ Page 35 Program examples

Point

Using function blocks (FBs) reduces load at programming and improves the readability of programs. For details on the function blocks, refer to the following.

📖 MELSEC iQ-R Analog-Digital Converter Module/Digital-Analog Converter Module Function Block Reference

6.2 Program Examples

System configuration

The following figure shows an example of the system configuration.

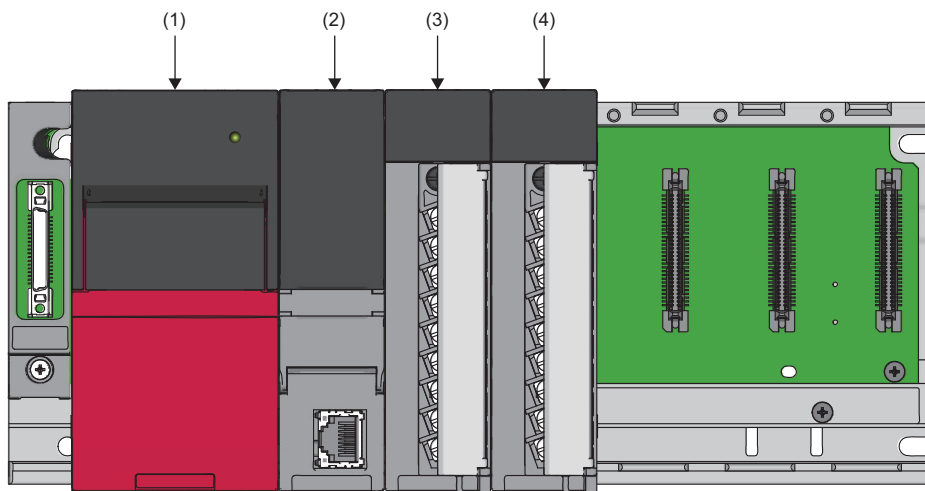

- (1) Power supply module (R61P)
- (2) CPU module (R120CPU)
- (3) D/A converter module (R60DA4)
- (4) Input module (RX10)

Parameter setting

Configure the initial setting in the parameter setting of an engineering tool. The auto refresh setting does not need to be changed here.

For details on the parameter setting, refer to the following.

📖 MELSEC iQ-R Digital-Analog Converter Module User's Manual (Application)

Function	Setting item	CH1	CH2	CH3	CH4
Range switching function	Output range setting	-10 to 10V	-10 to 10V	0 to 20mA	4 to 20mA
Operation mode setting function	Drive mode setting	Normal (D/A conversion process) mode			
	Output mode setting	Normal output mode			
Output mode setting function	Analog output HOLD/CLEAR function setting	HOLD	CLEAR	HOLD	HOLD
D/A conversion enable/disable setting function	D/A conversion enable/disable setting	D/A conversion enabled	D/A conversion enabled	D/A conversion enabled	D/A conversion enabled
Scaling function	Scaling enable/disable setting	Disable	Disable	Enable	Disable
	Scaling lower limit value	—	—	2000	—
	Scaling upper limit value	—	—	16000	—
Shift function	Input value shift amount	0	0	2000	0
Alert output function	Warning output setting	Disable	Enable	Disable	Disable
	Warning output lower limit value	—	0	—	—
	Warning output upper limit value	—	32000	—	—
Rate control function	Rate control enable/disable setting	Enable	Disable	Disable	Disable
	Increase digital limit value	8000	—	—	—
	Decrease digital limit value	1600	—	—	—

Label setting

GX Works3 provides functions that support the creation of a program.

The following table lists the module labels and global labels used for the program examples in this section.

There is no need to change the setting of the module labels. For details on the global labels, refer to the following.

 MELSEC iQ-R Programming Manual (Program Design)

Classification	Label name	Description	Device		
Module label	R60DA_1.bModuleREADY	Module READY	X0		
	R60DA_1.bExternalPowerSupplyREADY_Flag	External power supply READY flag	X7		
	R60DA_1.bDisconnectionDetectionSignal	Disconnection detection signal	X0D		
	R60DA_1.bWarningOutputSignal	Alert output signal	X0E		
	R60DA_1.bErrorFlag	Error flag	X0F		
	R60DA_1.bCH1OutputEnableDisableFlag	CH1 Output enable/disable flag	Y1		
	R60DA_1.bCH2OutputEnableDisableFlag	CH2 Output enable/disable flag	Y2		
	R60DA_1.bCH3OutputEnableDisableFlag	CH3 Output enable/disable flag	Y3		
	R60DA_1.bCH4OutputEnableDisableFlag	CH4 Output enable/disable flag	Y4		
	R60DA_1.bWarningOutputClearRequest	Warning output clear request	Y0E		
	R60DA_1	Target module	—		
	R60DA_1.stnControl[0].wDigitalValue	CH1 Digital value	—		
	R60DA_1.stnControl[1].wDigitalValue	CH2 Digital value	—		
	R60DA_1.stnControl[2].wDigitalValue	CH3 Digital value	—		
	R60DA_1.stnControl[3].wDigitalValue	CH4 Digital value	—		
	R60DA_1.uDisconnectionDetectionFlag.3	Disconnection detection flag	—		
	R60DA_1.uWarningOutputUpperFlag.1	Warning output upper flag	—		
	R60DA_1.uWarningOutputLowerFlag.1	Warning output lower flag	—		
	Labels to be defined	Define global labels as shown below:			
			Label Name	Data Type	Class
1		CH1_DigInVal	Word [Signed]	VAR_GLOBAL	D11
2		CH2_DigInVal	Word [Signed]	VAR_GLOBAL	D12
3		CH3_DigInVal	Word [Signed]	VAR_GLOBAL	D13
4		CH4_DigInVal	Word [Signed]	VAR_GLOBAL	D14
5		CH2_AlmUpLimit	Bit	VAR_GLOBAL	F0
6		CH2_AlmLowLimit	Bit	VAR_GLOBAL	F1
7		CH4_DisconnectDetect	Bit	VAR_GLOBAL	F2
8		DigitWriteSig	Bit	VAR_GLOBAL	X10
9		DAOutputSig	Bit	VAR_GLOBAL	X11
10		WarningOutClrSig	Bit	VAR_GLOBAL	X12
11		ErrResetSig	Bit	VAR_GLOBAL	X13
12		ErrOperationEN	Bit	VAR_GLOBAL	
13		ErrOperationENO	Bit	VAR_GLOBAL	
14		ErrOperationOK	Bit	VAR_GLOBAL	
15		UnitErrFlg	Bit	VAR_GLOBAL	
16		UnitErrCode	Word [Signed]	VAR_GLOBAL	
17	UnitAlarmCode	Word [Signed]	VAR_GLOBAL		

Program examples

Program example 1

- The following figure shows an example of a program that enables the analog output and starts the D/A conversion after digital values for the D/A conversion of CH1 to CH4 are set in the D/A converter module.

	1	2	3	4	5	6	7	8	9	10
(11)	DigitWriteSig X10	R60DA_1.bModuleREADY X0	R60DA_1.bExternalPowerSupplyREADY_Flag X7					MOV	CH1_DigInVal D11	R60DA_1.stnControl [0].wDigitalValue
								MOV	CH2_DigInVal D12	R60DA_1.stnControl [1].wDigitalValue
								MOV	CH3_DigInVal D13	R60DA_1.stnControl [2].wDigitalValue
								MOV	CH4_DigInVal D14	R60DA_1.stnControl [3].wDigitalValue
(95)	DAOutputSig X11	R60DA_1.bModuleREADY X0	R60DA_1.bExternalPowerSupplyREADY_Flag X7							R60DA_1.bCH1OutputEnableDisableFlag Y1
										R60DA_1.bCH2OutputEnableDisableFlag Y2
										R60DA_1.bCH3OutputEnableDisableFlag Y3
										R60DA_1.bCH4OutputEnableDisableFlag Y4
(142)										[END]

- (11) Sets CH1 Digital value to CH4 Digital value.
 (95) Enables the output of CH1 to CH4.

■ Program example 2

- The following figure shows an example of a program that clears the processing when an alert output occurs in the CH2 and the alert output in the D/A converter module.

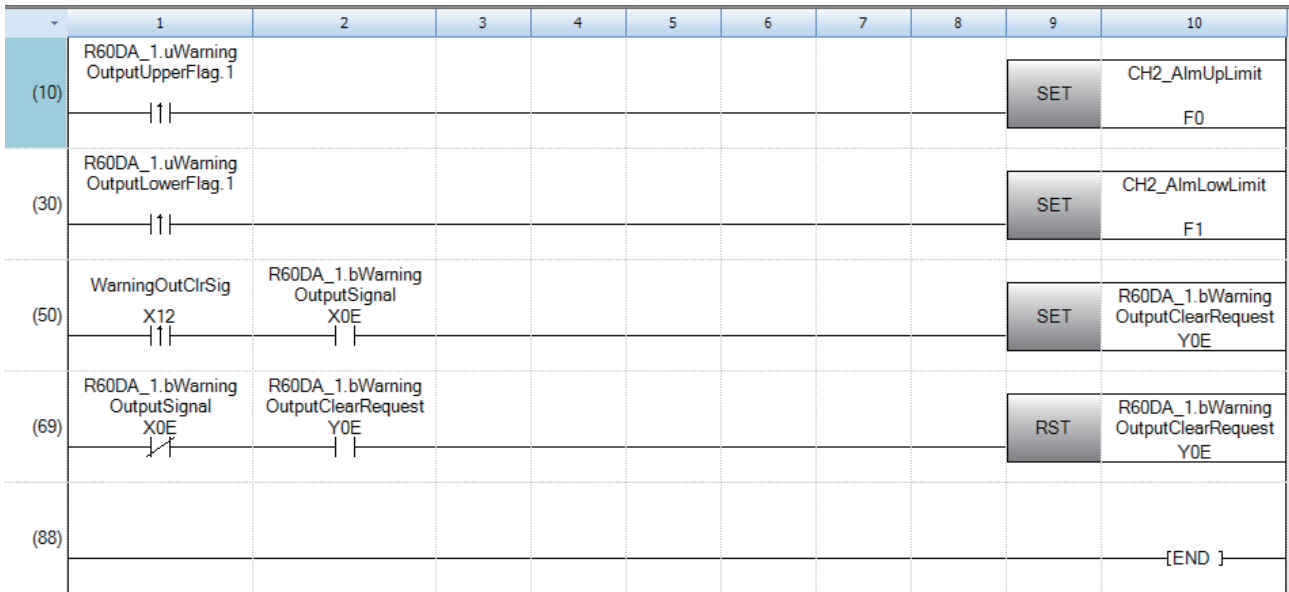

- (10) At the time when an upper limit alert is issued in CH2, the processing is to be performed.
 (30) At the time when a lower limit alert is issued in CH2, the processing is to be performed.
 (50) Turns on 'Warning output clear request' (YE).
 (69) Turns off 'Warning output clear request' (YE).

Program example 3

- The following figure shows an example of a program that displays the latest error code when a disconnection is detected in CH4 or an error occurs in the D/A converter module. After that, the program clears the disconnection detection flag, error flag, and the stored error code.

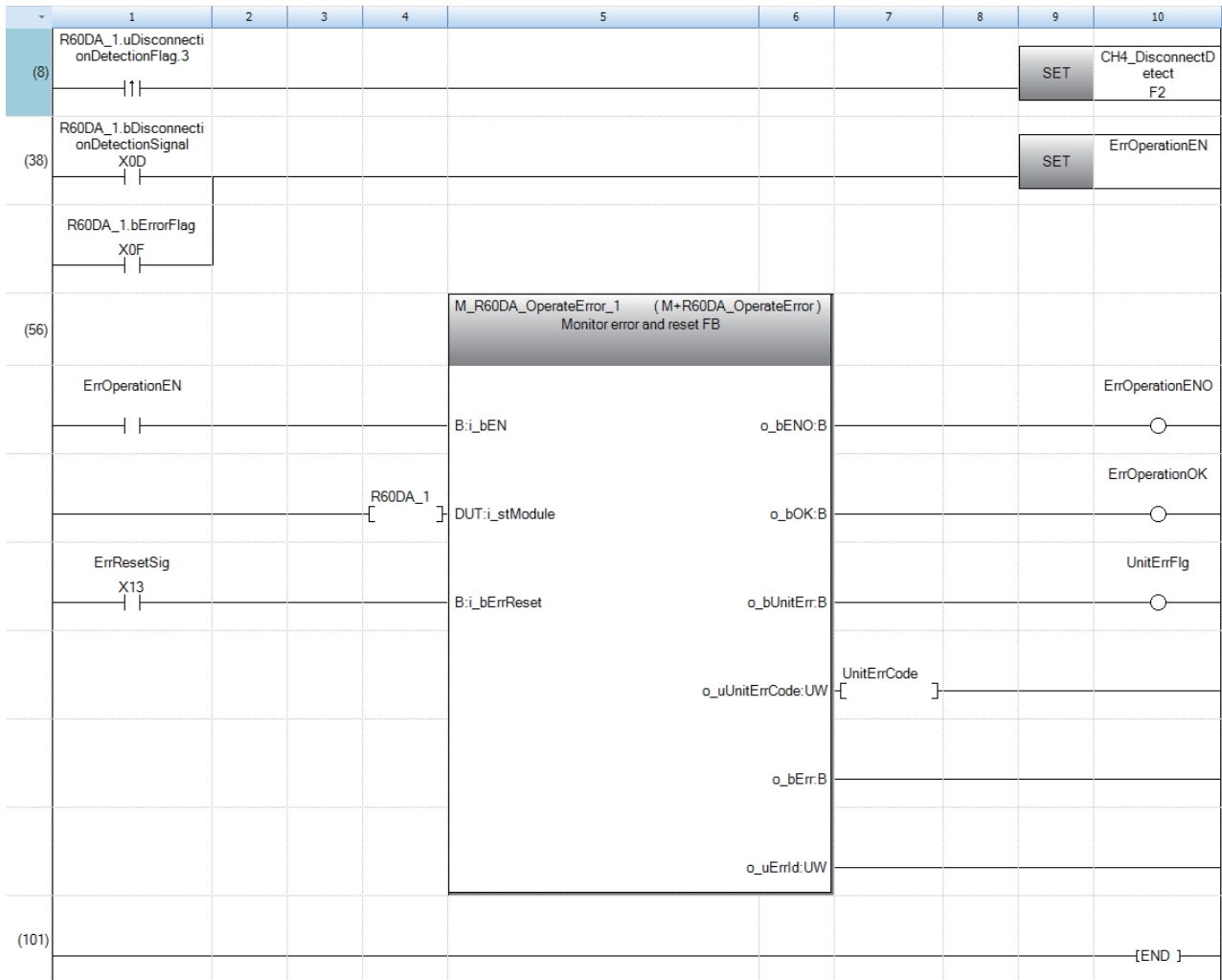

- (8) Performs the processing of when a disconnection is detected.
- (38) Error manipulation start flag is turned on.

7 OFFSET/GAIN SETTING

When using the user range setting, configure the offset/gain setting.

Access to the offset/gain setting window in the engineering tool to set the offset/gain setting.

7.1 Setting Procedure

The setting procedure for the offset/gain setting of the D/A converter module is as follows:

 [Tool] ⇒ [Module Tool List]

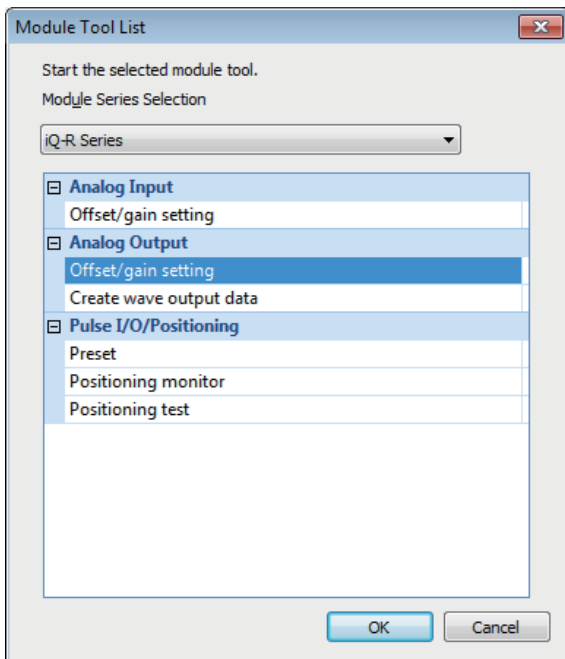

1. Select "Analog Output" ⇒ "Offset/gain setting" and click the [OK] button.

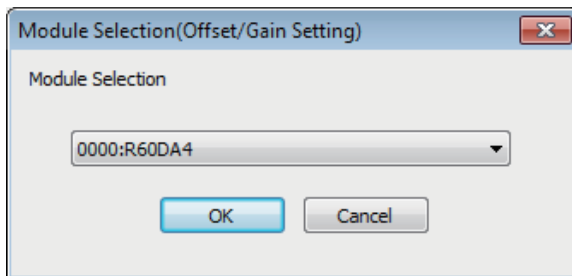

2. Select the target module for the offset/gain setting, and click [OK] button.

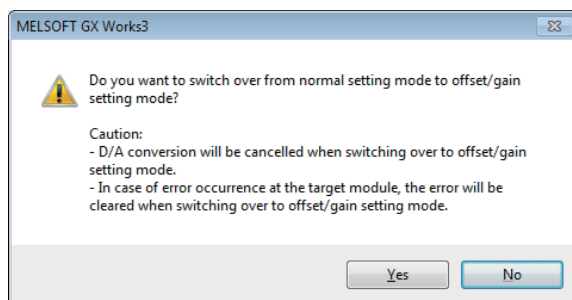

3. Click the [Yes] button.

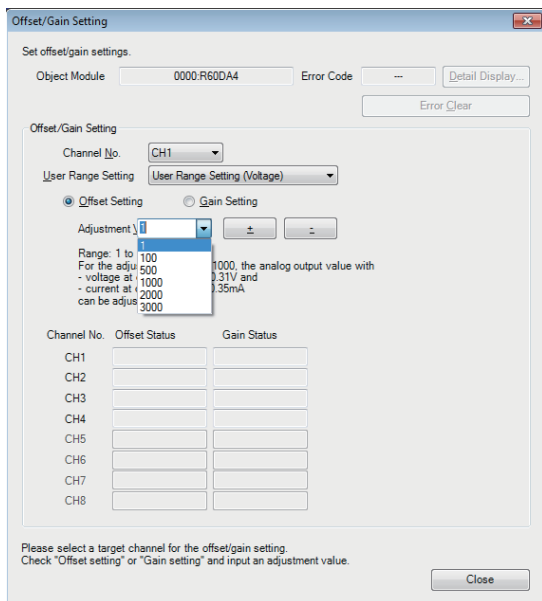
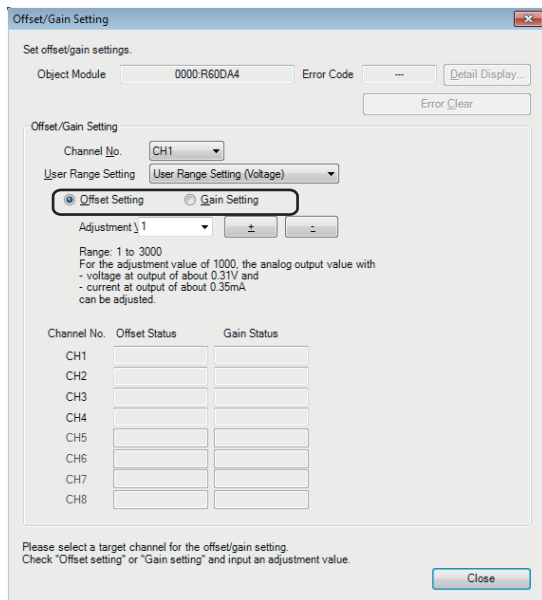
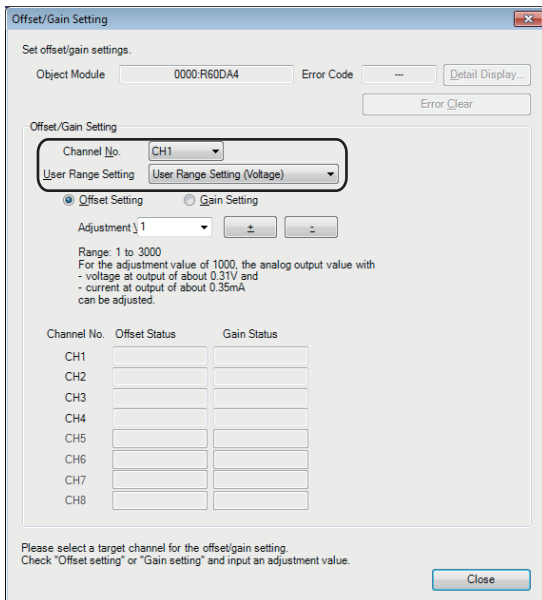

4. Specify the channel to configure the offset/gain setting and the user range setting.

5. Use the radio button to specify whether to perform the offset setting or gain setting. (Step 6 and later describe the case when the offset setting is specified.)

6. The adjustment amount of the offset value or gain value can be selected from "1", "100", "500", "1000", "2000", and "3000" or it can be set by inputting any value (1 to 3000).

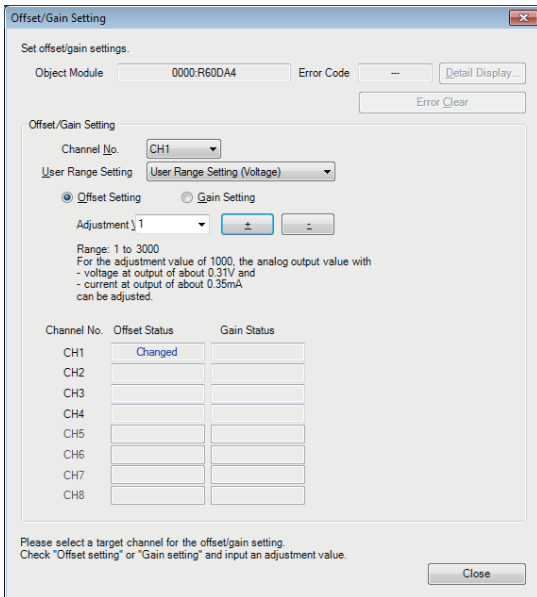

7. Clicking the [+ (+)] or [- (-)] button fine-tunes the analog output voltage or analog output current value corresponding the set adjustment value.
8. Check that the offset setting status in the selected channel has changed to "Changed".
9. To perform the gain setting, repeat the procedure from step 5.
10. After setting is completed, click the [Close] button.

11. Click the [Yes] button.

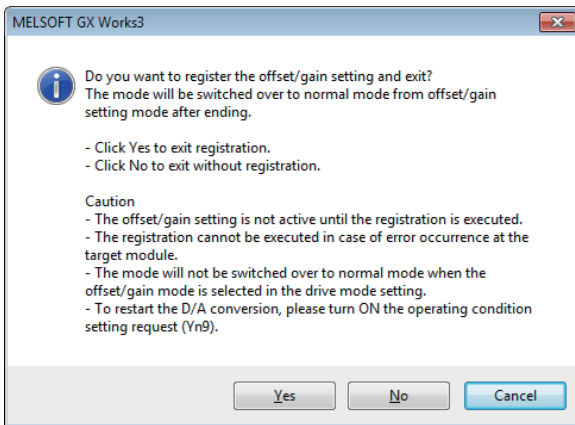

APPENDICES

Appendix 1 I/O Conversion Characteristics

An I/O conversion characteristic of D/A conversion is expressed by the slope of the straight line connecting the offset value and the gain value at the time when a digital value written from the CPU module is converted to an analog output value (voltage or current).

Offset value

This analog output value (voltage or current) corresponds to a digital value of 0 that is set through the CPU module.

Gain value

This analog output value (voltage or current) corresponds to a digital value of 32000 that is set through the CPU module.

Voltage output characteristic

The following shows the list of the analog output ranges and the graphs of each voltage output characteristic, at the voltage output.

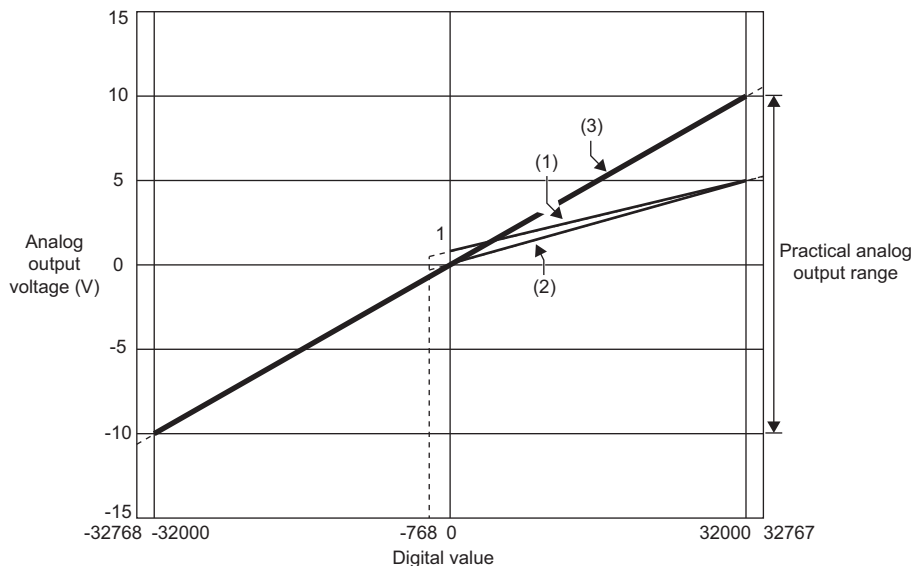

No.	Analog output range setting	Offset value	Gain value	Digital value	Resolution
(1)	1 to 5V	1V	5V	0 to 32000	125.0 μ V
(2)	0 to 5V	0V	5V		156.3 μ V
(3)	-10 to 10V	0V	10V	-32000 to 32000	312.5 μ V
—	User range setting (Voltage)	*1	*1	-32000 to 32000	312.5 μ V ^{*2}

*1 Set the offset value and gain value in the user range setting within a range that satisfies the following conditions. If the following conditions are not satisfied, D/A conversion may not be performed properly.

- Setting range of the offset value and gain value: -10 to 10V
- ((gain value) - (offset value)) \geq 4.0V

*2 Maximum resolution in the user range setting.

Point

- Set values within the practical range of the digital input and analog output at each output range. If the values are out of the range, the resolution and accuracy may not fall within the range of the performance specifications. (Do not use values in the dotted line region in the graph of voltage output characteristics.)

Current output characteristic

The following shows the list of the analog output ranges and the graphs of each current output characteristic, at the current output.

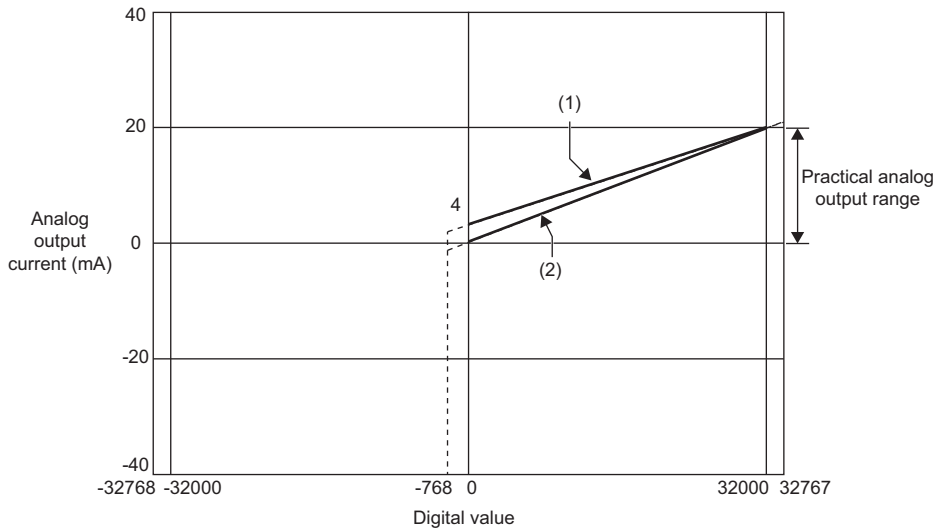

No.	Analog output range setting	Offset value	Gain value	Digital value	Resolution
(1)	4 to 20mA	4mA	20mA	0 to 32000	500.0nA
(2)	0 to 20mA	0mA	20mA		625.0nA
—	User range setting (Current)	*1	*1	-32000 to 32000	350.9nA*2

*1 Set the offset value and gain value in the user range setting within a range that satisfies the following conditions. If the following conditions are not satisfied, D/A conversion may not be performed properly.

- Offset value ≥ 0 mA, gain value ≤ 20 mA
- ((gain value) - (offset value)) ≥ 11.3 mA

*2 Maximum resolution in the user range setting.

Point

- Set values within the practical range of the digital input and analog output at each output range. If the values are out of the range, the resolution and accuracy may not fall within the range of the performance specifications. (Do not use values in the dotted line region in the graph of current output characteristics.)

Appendix 2 Accuracy

Accuracy of D/A conversion is determined by the accuracy for the maximum value of analog output value.

An output characteristic change through changes of the offset/gain setting or the output range does not sacrifice the accuracy, which is maintained within the described range of the performance specifications.

The following graph shows the fluctuation range of accuracy when the range of -10 to 10V is selected.

The accuracy is $\pm 0.1\%$ ($\pm 10\text{mV}$) at ambient temperature of $25 \pm 5^\circ\text{C}$; the accuracy is $\pm 0.3\%$ ($\pm 30\text{mV}$) at ambient temperature of 0 to 55°C . (except for the conditions under noise.)

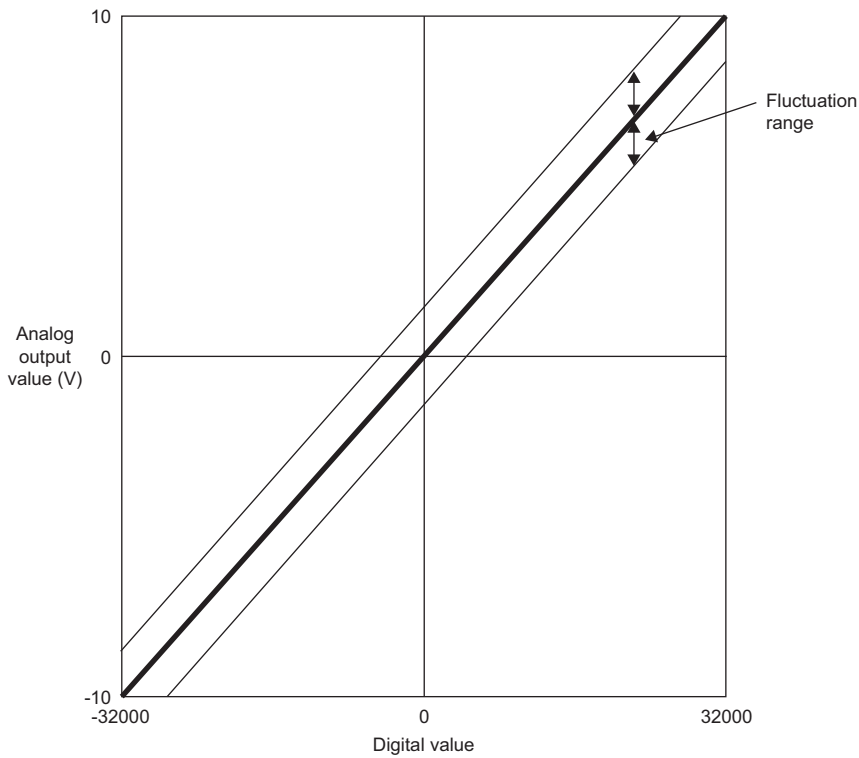

Appendix 3 External Dimensions

The following figure shows the external dimensions of the D/A converter module.

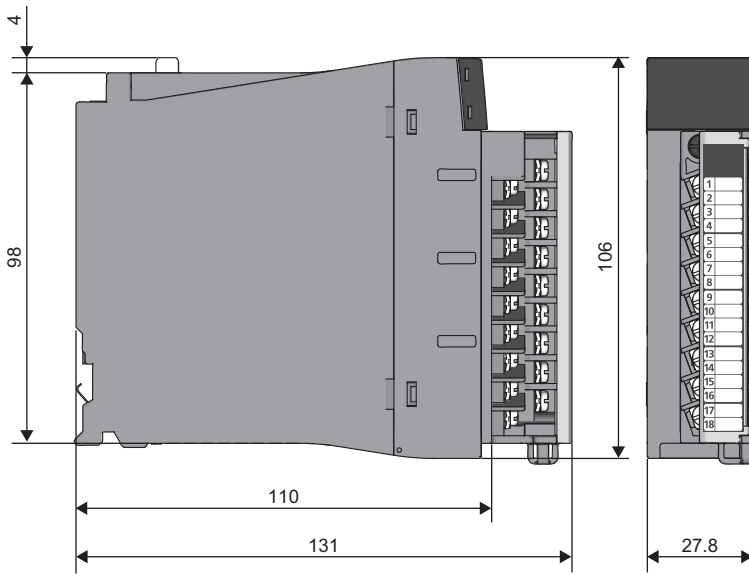

(Unit: mm)

MEMO

INDEX

A

Accuracy 44

C

Current output characteristic 43

E

External dimensions 45

External wiring 29

F

Function block (FB) 32

G

Gain value 41

O

Offset value 41

Offset/gain setting 38

T

Terminal block 27

V

Voltage output characteristic 42

MEMO



REVISIONS

*The manual number is given on the bottom left of the back cover.

Print data	*Manual number	Revision
June 2014	SH(NA)-081235ENG-A	First edition
January 2015	SH(NA)-081235ENG-B	■Added function Online module change ■Added or modified parts RELEVANT MANUALS, Chapter 1, Section 2.1

*Japanese manual number: SH-081234-B

This manual confers no industrial property rights or any rights of any other kind, nor does it confer any patent licenses. Mitsubishi Electric Corporation cannot be held responsible for any problems involving industrial property rights which may occur as a result of using the contents noted in this manual.

© 2014 MITSUBISHI ELECTRIC CORPORATION

WARRANTY

Please confirm the following product warranty details before using this product.

1. Gratis Warranty Term and Gratis Warranty Range

If any faults or defects (hereinafter "Failure") found to be the responsibility of Mitsubishi occurs during use of the product within the gratis warranty term, the product shall be repaired at no cost via the sales representative or Mitsubishi Service Company.

However, if repairs are required onsite at domestic or overseas location, expenses to send an engineer will be solely at the customer's discretion. Mitsubishi shall not be held responsible for any re-commissioning, maintenance, or testing on-site that involves replacement of the failed module.

[Gratis Warranty Term]

The gratis warranty term of the product shall be for one year after the date of purchase or delivery to a designated place. Note that after manufacture and shipment from Mitsubishi, the maximum distribution period shall be six (6) months, and the longest gratis warranty term after manufacturing shall be eighteen (18) months. The gratis warranty term of repair parts shall not exceed the gratis warranty term before repairs.

[Gratis Warranty Range]

- (1) The range shall be limited to normal use within the usage state, usage methods and usage environment, etc., which follow the conditions and precautions, etc., given in the instruction manual, user's manual and caution labels on the product.
- (2) Even within the gratis warranty term, repairs shall be charged for in the following cases.
 1. Failure occurring from inappropriate storage or handling, carelessness or negligence by the user. Failure caused by the user's hardware or software design.
 2. Failure caused by unapproved modifications, etc., to the product by the user.
 3. When the Mitsubishi product is assembled into a user's device, Failure that could have been avoided if functions or structures, judged as necessary in the legal safety measures the user's device is subject to or as necessary by industry standards, had been provided.
 4. Failure that could have been avoided if consumable parts (battery, backlight, fuse, etc.) designated in the instruction manual had been correctly serviced or replaced.
 5. Failure caused by external irresistible forces such as fires or abnormal voltages, and Failure caused by force majeure such as earthquakes, lightning, wind and water damage.
 6. Failure caused by reasons unpredictable by scientific technology standards at time of shipment from Mitsubishi.
 7. Any other failure found not to be the responsibility of Mitsubishi or that admitted not to be so by the user.

2. Onerous repair term after discontinuation of production

- (1) Mitsubishi shall accept onerous product repairs for seven (7) years after production of the product is discontinued. Discontinuation of production shall be notified with Mitsubishi Technical Bulletins, etc.
- (2) Product supply (including repair parts) is not available after production is discontinued.

3. Overseas service

Overseas, repairs shall be accepted by Mitsubishi's local overseas FA Center. Note that the repair conditions at each FA Center may differ.

4. Exclusion of loss in opportunity and secondary loss from warranty liability

Regardless of the gratis warranty term, Mitsubishi shall not be liable for compensation of damages caused by any cause found not to be the responsibility of Mitsubishi, loss in opportunity, lost profits incurred to the user by Failures of Mitsubishi products, special damages and secondary damages whether foreseeable or not, compensation for accidents, and compensation for damages to products other than Mitsubishi products, replacement by the user, maintenance of on-site equipment, start-up test run and other tasks.

5. Changes in product specifications

The specifications given in the catalogs, manuals or technical documents are subject to change without prior notice.

TRADEMARKS

Microsoft, Windows, Windows Vista, Windows NT, Windows XP, Windows Server, Visio, Excel, PowerPoint, Visual Basic, Visual C++, and Access are either registered trademarks or trademarks of Microsoft Corporation in the United States, Japan, and other countries.

Intel, Pentium, and Celeron are trademarks of Intel Corporation in the United States and other countries.

Ethernet is a trademark of Xerox Corp.

The SD and SDHC logos are either registered trademarks or trademarks of SD-3C, LLC.

All other company names and product names used in this manual are either trademarks or registered trademarks of their respective companies.



SH(NA)-081235ENG-B(1501)MEE

MODEL: R-DA-U-IN-E

MODEL CODE: 13JX04

mitsubishi electric corporation

HEAD OFFICE : TOKYO BUILDING, 2-7-3 MARUNOUCHI, CHIYODA-KU, TOKYO 100-8310, JAPAN
NAGOYA WORKS : 1-14, YADA-MINAMI 5-CHOME, HIGASHI-KU, NAGOYA, JAPAN

When exported from Japan, this manual does not require application to the
Ministry of Economy, Trade and Industry for service transaction permission.

Specifications subject to change without notice.