

**Servomotors/Servo Drivers**  
**MODELS R7M-Z□ (Servomotors)**  
**R7D-ZP□ (Servo Drivers)**

**SMARTSTEP Junior**

**USER'S MANUAL**

**OMRON**

Thank you for choosing this SMARTSTEP Junior product.

This manual provides information on installation, wiring, and switch setting for the SMARTSTEP Junior Servomotors and Servo Drivers. For information about troubleshooting, refer to the *SMARTSTEP Junior User's Manual* (Cat. No. I553).

### ■ Intended Audiences

This manual is intended for the following personnel, who must also have knowledge of electrical systems (an electrical engineer or the equivalent).

- Personnel in charge of installing FA systems
- Personnel in charge of designing FA systems
- Personnel in charge of managing FA systems and facilities

### ■ NOTICE

This manual contains information necessary for the operation of the SMARTSTEP Junior Servomotors and Servo Drivers. Please read this manual thoroughly and understand its contents before attempting to operate the product. Please keep this manual handy for future reference after reading it.

Be sure that this manual accompanies the product to its final user.

### © OMRON, 2006

All rights reserved. No part of this publication may be reproduced, stored in a retrieval system, or transmitted, in any form, or by any means, mechanical, electronic, photocopying, recording, or otherwise, without the prior written permission of OMRON.

No patent liability is assumed with respect to the use of the information contained herein. Moreover, because OMRON is constantly striving to improve its high-quality products, the information contained in this manual is subject to change without notice. Every precaution has been taken in the preparation of this manual. Nevertheless, OMRON assumes no responsibility for errors or omissions. Neither is any liability assumed for damages resulting from the use of the information contained in this publication.



## ***Read and Understand this Manual***

Please read and understand this manual before using the product. Please consult your OMRON representative if you have any questions or comments.

## ***Warranty and Limitations of Liability***

### ***WARRANTY***

OMRON's exclusive warranty is that the products are free from defects in materials and workmanship for a period of one year (or other period if specified) from date of sale by OMRON.

OMRON MAKES NO WARRANTY OR REPRESENTATION, EXPRESS OR IMPLIED, REGARDING NON-INFRINGEMENT, MERCHANTABILITY, OR FITNESS FOR PARTICULAR PURPOSE OF THE PRODUCTS. ANY BUYER OR USER ACKNOWLEDGES THAT THE BUYER OR USER ALONE HAS DETERMINED THAT THE PRODUCTS WILL SUITABLY MEET THE REQUIREMENTS OF THEIR INTENDED USE. OMRON DISCLAIMS ALL OTHER WARRANTIES, EXPRESS OR IMPLIED.

### ***LIMITATIONS OF LIABILITY***

OMRON SHALL NOT BE RESPONSIBLE FOR SPECIAL, INDIRECT, OR CONSEQUENTIAL DAMAGES, LOSS OF PROFITS OR COMMERCIAL LOSS IN ANY WAY CONNECTED WITH THE PRODUCTS, WHETHER SUCH CLAIM IS BASED ON CONTRACT, WARRANTY, NEGLIGENCE, OR STRICT LIABILITY.

In no event shall the responsibility of OMRON for any act exceed the individual price of the product on which liability is asserted.

IN NO EVENT SHALL OMRON BE RESPONSIBLE FOR WARRANTY, REPAIR, OR OTHER CLAIMS REGARDING THE PRODUCTS UNLESS OMRON'S ANALYSIS CONFIRMS THAT THE PRODUCTS WERE PROPERLY HANDLED, STORED, INSTALLED, AND MAINTAINED AND NOT SUBJECT TO CONTAMINATION, ABUSE, MISUSE, OR INAPPROPRIATE MODIFICATION OR REPAIR.

## ***Application Considerations***

### ***SUITABILITY FOR USE***

OMRON shall not be responsible for conformity with any standards, codes, or regulations that apply to the combination of products in the customer's application or use of the products.

At the customer's request, OMRON will provide applicable third party certification documents identifying ratings and limitations of use that apply to the products. This information by itself is not sufficient for a complete determination of the suitability of the products in combination with the end product, machine, system, or other application or use.

The following are some examples of applications for which particular attention must be given. This is not intended to be an exhaustive list of all possible uses of the products, nor is it intended to imply that the uses listed may be suitable for the products:

- Outdoor use, uses involving potential chemical contamination or electrical interference, or conditions or uses not described in this manual.
- Nuclear energy control systems, combustion systems, railroad systems, aviation systems, medical equipment, amusement machines, vehicles, safety equipment, and installations subject to separate industry or government regulations.
- Systems, machines, and equipment that could present a risk to life or property.

Please know and observe all prohibitions of use applicable to the products.

**NEVER USE THE PRODUCTS FOR AN APPLICATION INVOLVING SERIOUS RISK TO LIFE OR PROPERTY WITHOUT ENSURING THAT THE SYSTEM AS A WHOLE HAS BEEN DESIGNED TO ADDRESS THE RISKS, AND THAT THE OMRON PRODUCTS ARE PROPERLY RATED AND INSTALLED FOR THE INTENDED USE WITHIN THE OVERALL EQUIPMENT OR SYSTEM.**

### ***PROGRAMMABLE PRODUCTS***

OMRON shall not be responsible for the user's programming of a programmable product, or any consequence thereof.

## ***Disclaimers***

### ***CHANGE IN SPECIFICATIONS***

Product specifications and accessories may be changed at any time based on improvements and other reasons.

It is our practice to change model numbers when published ratings or features are changed, or when significant construction changes are made. However, some specifications of the products may be changed without any notice. When in doubt, special model numbers may be assigned to fix or establish key specifications for your application on your request. Please consult with your OMRON representative at any time to confirm actual specifications of purchased products.

### ***DIMENSIONS AND WEIGHTS***

Dimensions and weights are nominal and are not to be used for manufacturing purposes, even when tolerances are shown.

### ***PERFORMANCE DATA***

Performance data given in this manual is provided as a guide for the user in determining suitability and does not constitute a warranty. It may represent the result of OMRON's test conditions, and the users must correlate it to actual application requirements. Actual performance is subject to the OMRON Warranty and Limitations of Liability.

### ***ERRORS AND OMISSIONS***

The information in this manual has been carefully checked and is believed to be accurate; however, no responsibility is assumed for clerical, typographical, or proofreading errors, or omissions.

## General Warnings

To ensure safe and proper use of SMARTSTEP Junior Servomotors and Servo Drivers, read the general warnings provided below along with the rest of this manual to gain sufficient knowledge of the devices, safety information, and precautions before actual use.

This OPERATION MANUAL is to be delivered to the actual end users of the products.

Please keep this manual close at hand for future reference.

The following conventions are used to indicate and classify precautions in this manual. Always heed the information provided with them. Failure to heed precautions can result in injury to people or damage to property.

**WARNING**

Indicates a potentially hazardous situation which, if not avoided, could result in death or serious injury. Additionally, there may be severe property damage.

**Caution**











Indicates a potentially hazardous situation which, if not avoided, may result in minor or moderate injury, or property damage.

## General Warnings

---

- This manual may include illustrations of the product with protective covers or shields removed in order to describe the components of the product in detail. Make sure that these protective covers and shields are on the product before use.
- Consult your OMRON representative when using the product after a long period of storage.

# WARNING

-  **WARNING** Always connect the frame ground terminals of the Servo Driver and the Servomotor to a class-3 ground (to 100  $\Omega$  or less). Not connecting to a class-3 ground may result in electric shock.
-  **WARNING** Do not touch the inside of the Servo Driver. Doing so may result in electric shock.
-  **WARNING** Do not remove the front cover, terminal covers, cables, or optional items while the power is being supplied. Doing so may result in electric shock.
-  **WARNING** Installation, operation, maintenance, or inspection must be performed by authorized personnel. Not doing so may result in electric shock or injury.
-  **WARNING** Wiring or inspection must not be performed for at least five minutes after turning OFF the power supply. Doing so may result in electric shock.
-  **WARNING** Do not damage, press, or put excessive stress or heavy objects on the cables. Doing so may result in electric shock.
-  **WARNING** Do not touch the rotating parts of the Servomotor in operation. Doing so may result in injury.
-  **WARNING** Do not modify the product. Doing so may result in injury or damage to the product.
-  **WARNING** Provide a stopping mechanism on the machine to ensure safety. The holding brake is not designed as a stopping mechanism for safety purposes.
-  **WARNING** Provide an external emergency stopping mechanism that can stop operation and shutting off the power supply immediately. Not doing so may result in injury.
-  **WARNING** Do not come close to the machine immediately after resetting momentary power interruption to avoid an unexpected restart. (Take appropriate measures to secure safety against an unexpected restart.) Doing so may result in injury.





## CAUTION



### Caution

Use the Servomotors and Servo Drivers in a specified combination. Using them incorrectly may result in fire or damage to the products.

Do not store or install the product in the following places. Doing so may result in fire, electric shock, or damage to the product

- Locations subject to direct sunlight.
- Locations subject to temperatures or humidity outside the range specified in the specifications.
- Locations subject to condensation as the result of severe changes in temperature.
- Locations subject to corrosive or flammable gases.
- Locations subject to dust (especially iron dust) or salts.
- Locations subject to shock or vibration.
- Locations subject to exposure to water, oil, or chemicals.



### Caution

Do not touch the Servo Driver radiator, Servo Driver regeneration resistor, or Servomotor while the power is being supplied or soon after the power is turned OFF.

Doing so may result in a skin burn due to the hot surface.

## Storage and Transportation Precautions



## CAUTION



### Caution

Do not hold the product by the cables or motor shaft while transporting it. Doing so may result in injury or malfunction.















### Caution

Do not place any load exceeding the figure indicated on the product. Doing so may result in injury or malfunction.







## Installation and Wiring Precautions

# CAUTION

-  **Caution** Do not step on or place a heavy object on the product. Doing so may result in injury.
-  **Caution** Do not cover the inlet or outlet ports and prevent any foreign objects from entering the product. Doing so may result in fire.
-  **Caution** Be sure to install the product in the correct direction. Not doing so may result in malfunction.
-  **Caution** Provide the specified clearances between the Servo Driver and the control panel or with other devices. Not doing so may result in fire or malfunction.
-  **Caution** Do not apply any strong impact. Doing so may result in malfunction.
-  **Caution** Be sure to wire correctly and securely. Not doing so may result in motor runaway, injury, or malfunction.
-  **Caution** Be sure that all the mounting screws, terminal screws, and cable connector screws are tightened to the torque specified in the relevant manuals. Incorrect tightening torque may result in malfunction.
-  **Caution** Use crimp terminals for wiring. Do not connect bare stranded wires directly to terminals. Connection of bare stranded wires may result in burning.
-  **Caution** Always use the power supply voltage specified in the *User's Manual*. An incorrect voltage may result in malfunction or burning.
-  **Caution** Take appropriate measures to ensure that the specified power with the rated voltage and frequency is supplied. Be particularly careful in places where the power supply is unstable. An incorrect power supply may result in malfunction.
-  **Caution** Install external breakers and take other safety measures against short-circuiting in external wiring. Insufficient safety measures against short-circuiting may result in burning.
-  **Caution** Take appropriate and sufficient countermeasures when installing systems in the following locations. Failure to do so may result in damage to the product.
  - Locations subject to static electricity or other forms of noise.
  - Locations subject to strong electromagnetic fields and magnetic fields.
  - Locations subject to possible exposure to radioactivity.
  - Locations close to power supplies.



## Operation and Adjustment Precautions

### CAUTION

-  **Caution** Confirm that no adverse effects will occur in the system before performing the test operation. Not doing so may result in equipment damage.
-  **Caution** Check the newly set parameters and switches for proper execution before actually running them. Not doing so may result in equipment damage.
-  **Caution** Do not make any extreme adjustments or setting changes. Doing so may result in unstable operation and injury.
-  **Caution** Separate the Servomotor from the machine, check for proper operation, and then connect to the machine. Not doing so may cause injury.
-  **Caution** When an alarm occurs, remove the cause, reset the alarm after confirming safety, and then resume operation. Not doing so may result in injury.
-  **Caution** Do not use the built-in brake of the Servomotor for ordinary braking. Doing so may result in malfunction.
-  **Caution** Do not operate the Servomotor connected to a load that exceeds the applicable load moment of inertia. Doing so may result in malfunction.

## Maintenance and Inspection Precautions

### CAUTION

-  **WARNING** Do not attempt to disassemble, repair, or modify any Units. Any attempt to do so may result in malfunction, fire, or electric shock.
-  **Caution** Resume operation only after transferring to the new Unit the contents of the data required for operation. Not doing so may result in an unexpected operation.

## General Warnings

### ■ Warning Labels

Warning labels are pasted on the product as shown in the following illustration. Be sure to follow the instructions given there.

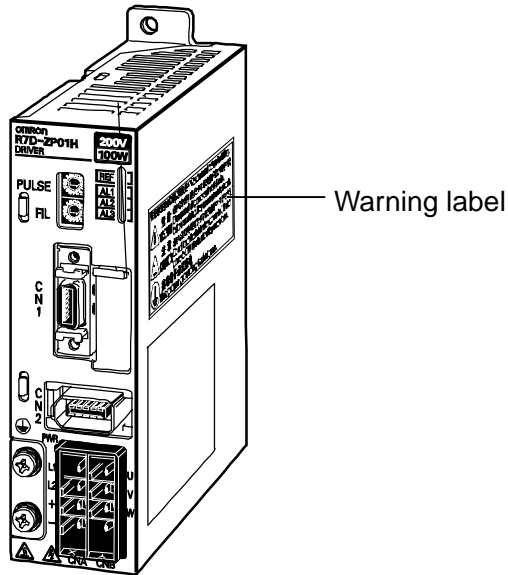

Example from R7D-ZP01H

### ■ Warning Label Contents



# Items to Check When Unpacking

Check the following items after removing the product from the package.

Item	Method
Has the correct product been delivered?	Check the model number on the nameplate on the side of the product.
Has the product been damaged in shipping?	Inspect the outside of the product and carefully check that there has been no damage during shipping.

- Accessories

1. Special screw driver for setting the rotary switch × 1



2. Safety Precautions document × 1

No connectors or mounting screws are provided. Obtain these separately.

If something is missing, the Servo Driver is damaged, or some other fault exists, please contact the point of purchase or your OMRON representative.

- Interpreting the Model Number

The model number provides information such as the Servo Driver type, the applicable Servomotor capacity, and the power supply voltage.

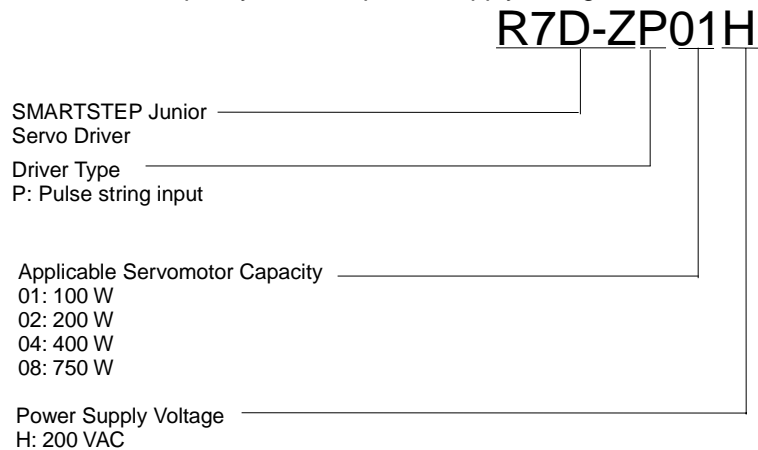

- Servo Driver and Servomotor Combinations

Rated output	Servomotor		Servo Driver
	Without brake	With brake	Pulse string input
100 W	R7M-Z10030-S1	R7M-Z10030-B S1	R7D-ZP01H
200 W	R7M-Z20030-S1	R7M-Z20030-B S1	R7D-ZP02H
400 W	R7M-Z40030-S1	R7M-Z40030-B S1	R7D-ZP04H
750 W	R7M-Z75030-S1	R7M-Z75030-B S1	R7D-ZP08H

---

**Section 1 Features and System Configuration**

---

**Section 2 Standard Models and Dimensions**

---

**Section 3 Specifications**

---

**Section 4 System Design**

---

**Section 5 Operation**

---

**Section 6 Troubleshooting**

---

**Appendix**

# Contents

Read and Understand this Manual.....	3
Warranty and Limitations of Liability.....	3
Application Considerations.....	4
Disclaimers .....	5
General Warnings.....	6
Items to Check When Unpacking.....	12
Contents .....	14

## Section 1 Features and System Configuration

1-1 Introduction.....	1-2
1-1-1 Introduction .....	1-2
1-1-2 SMARTSTEP Junior Features.....	1-2
1-2 System Configuration.....	1-3
1-3 Nomenclature and Functions .....	1-4
1-3-1 Servo Driver Nomenclature and Functions.....	1-4
1-4 System Block Diagrams .....	1-6
1-4-1 Pulse-train Input Servo Driver.....	1-6
1-5 Applicable Standards .....	1-7
1-5-1 EC Directives .....	1-7
1-5-2 UL and cUL Standards .....	1-7

## Section 2 Standard Models and Dimensions

2-1 Standard Models.....	2-2
2-1-1 Servo Drivers .....	2-2
2-1-2 Servomotors.....	2-2
2-1-3 Servo Driver-Servomotor Combinations.....	2-2
2-1-4 Decelerators (Straight Shaft with Key).....	2-3
2-1-5 Accessories and Cables .....	2-4
2-2 External and Mounted Dimensions .....	2-5
2-2-1 Servo Drivers .....	2-5
2-2-2 Servomotors.....	2-7
2-2-3 Decelerator Dimensions .....	2-9

## Section 3 Specifications

3-1 Servo Driver Specifications .....	3-2
3-1-1 General Specifications.....	3-2
3-1-2 Characteristics .....	3-3
3-1-3 Main Circuit and Servomotor Connector Specifications (CNA and CNB) .....	3-3

3-1-4	Control I/O Specifications (CN1).....	3-5
3-1-5	Control Input Circuits .....	3-7
3-1-6	Control Input Details .....	3-8
3-1-7	Control Output Circuits .....	3-10
3-1-8	Control Output Details .....	3-10
3-1-9	Encoder Connector Specifications (CN2) .....	3-11
3-2	Servomotor Specifications .....	3-13
3-2-1	General Specifications .....	3-13
3-2-2	Characteristics .....	3-14
3-2-3	Encoder Specifications .....	3-16
3-3	Decelerator Specifications .....	3-17
3-3-1	Standard Models and Specifications .....	3-17
3-4	Cable and Connector Specifications .....	3-18
3-4-1	Control Cable Specifications.....	3-18
3-4-2	Servomotor Power Cable Specifications .....	3-19
3-4-3	Encoder Cable Specifications.....	3-21
3-4-4	Connector Specifications .....	3-22
3-5	Regeneration Resistance Unit.....	3-24
3-5-1	Regeneration Resistance Unit (R88A-RG08UA) Specifications .....	3-24
3-6	AC Reactors .....	3-26
3-6-1	AC Reactor Specifications .....	3-26

## Section 4 System Design

4-1	Installation Conditions .....	4-2
4-1-1	Servo Drivers .....	4-2
4-1-2	Servomotors.....	4-3
4-1-3	Decelerators.....	4-5
4-2	Wiring .....	4-6
4-2-1	Connecting Cables.....	4-6
4-2-2	Selecting Connecting Cables.....	4-7
4-2-3	Peripheral Device Connection Examples .....	4-8
4-2-4	Wiring the Main Circuit and Servomotor Connections.....	4-9
4-2-5	Conforming to EMC Directives .....	4-11
4-3	Regenerative Energy Absorption .....	4-21
4-3-1	Calculating the Regenerative Energy .....	4-21
4-3-2	Servo Driver Regenerative Energy Absorption Capacity.....	4-23
4-3-3	Absorbing Regenerative Energy with an External Resistor.....	4-23

## Section 5 Operation

5-1	Operational Procedure .....	5-2
5-1-1	Operational Procedure.....	5-2
5-2	Switch Settings .....	5-3
5-2-1	Switch Names .....	5-3



5-2-2	Switch Functions .....	5-3
5-3	Preparing for Operation.....	5-5
5-3-1	Turning ON the Power and Checking Indicators .....	5-5
5-4	Trial Operation .....	5-7
5-4-1	Preparing for Trial Operation .....	5-7
5-4-2	Trial Operation .....	5-7
5-5	Operating Functions.....	5-9
5-5-1	Brake Interlock.....	5-9

## Section 6 Troubleshooting

6-1	Error Processing .....	6-2
6-1-1	Preliminary Checks when a Problem Occurs .....	6-2
6-1-2	Precautions When Troubleshooting.....	6-3
6-1-3	Replacing the Servomotor and Servo Driver .....	6-3
6-2	Alarm Table .....	6-4
6-2-1	Alarm Table.....	6-4
6-3	Troubleshooting .....	6-5
6-3-1	Error Diagnosis using the Alarm Indicators .....	6-5
6-3-2	Error Diagnosis using the Operating Status .....	6-8
6-4	Overload Characteristics (Electronic Thermal Function).....	6-11
6-4-1	Overload Characteristics Graphs.....	6-11
6-5	Periodic Maintenance .....	6-12
6-5-1	Servomotor Maintenance.....	6-12
6-5-2	Servo Driver Maintenance .....	6-13
6-5-3	Replacing the Cooling Fan .....	6-13

## Appendix

A-1	Connection Examples .....	A-2
	Revision History .....	R-1

# **Section 1**

---

## **Features and System Configuration**

# **1-1 Introduction**

## **1-1-1 Introduction**

The SMARTSTEP Junior is a Servo Driver with a pulse-string input for position control. The SMARTSTEP Junior is easy to set up and start because it does not require the complex parameter settings and Servo adjustments normally associated with Servos. The SMARTSTEP Junior Servomotor and Servo Driver are easy-to-use, yet provide the responsiveness, high-speed, high-torque, and precision of traditional Servo systems. This manual describes the SMARTSTEP Junior as a pulse-string input Servo Driver for position control.

## **1-1-2 SMARTSTEP Junior Features**

The SMARTSTEP Junior has the following features.

### **■ No Setup Parameters**

No parameter settings are required for setup, so you can start using the Servo Driver immediately simply by removing it from the box and wiring it. If it is necessary to set the positioning resolution or reference pulse method, these settings can be set or changed easily with the rotary switches on the front of the Servo Driver.

### **■ No Servo Adjustments Required**

With the newest auto-tuning function, it isn't necessary to adjust the Servo Driver to achieve excellent responsiveness. Auto-tuning achieves excellent responsiveness while providing compatibility with a range of stepping motors. A Servomotor with moderate inertia is used to improve control system stability.

# 1-2 System Configuration

**SYSMAC PLC + Position Control Unit with pulse-string output**

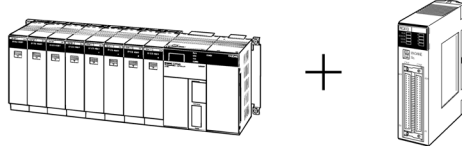

SYSMAC  
CJ1/CS1/C-series  
Programmable Controller

Position Control Unit  
CJ1W-NC113/213/413  
CJ1W-NC133/233/433  
CS1W-NC113/213/413  
CS1W-NC133/233/433  
C200HW-NC113/213/413

**SYSMAC PLC with pulse output functions**



SYSMAC CJ1M

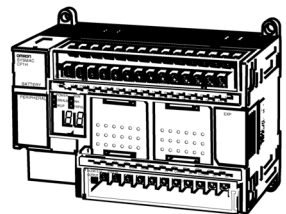

SYSMAC CP1H

**Flexible Motion Controller with pulse I/O**

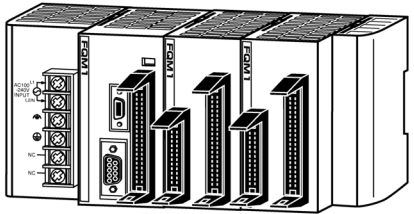

FQM1-MMP21

Pulse string

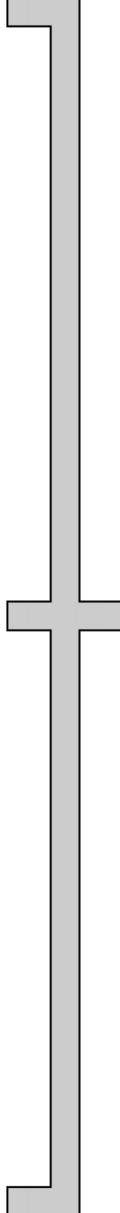
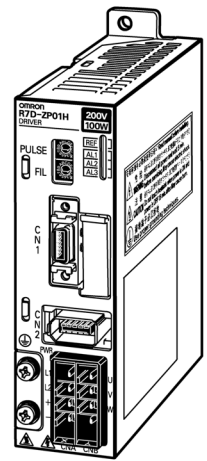
SMARTSTEP Junior Servo Driver  
R7D-ZP□

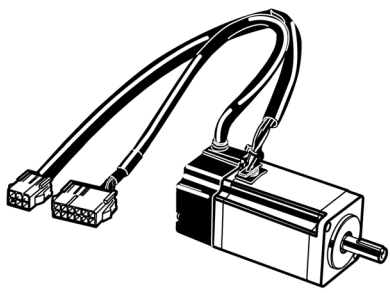

SMARTSTEP Junior Servomotor  
R7M-Z□

# 1-3 Nomenclature and Functions

## 1-3-1 Servo Driver Nomenclature and Functions

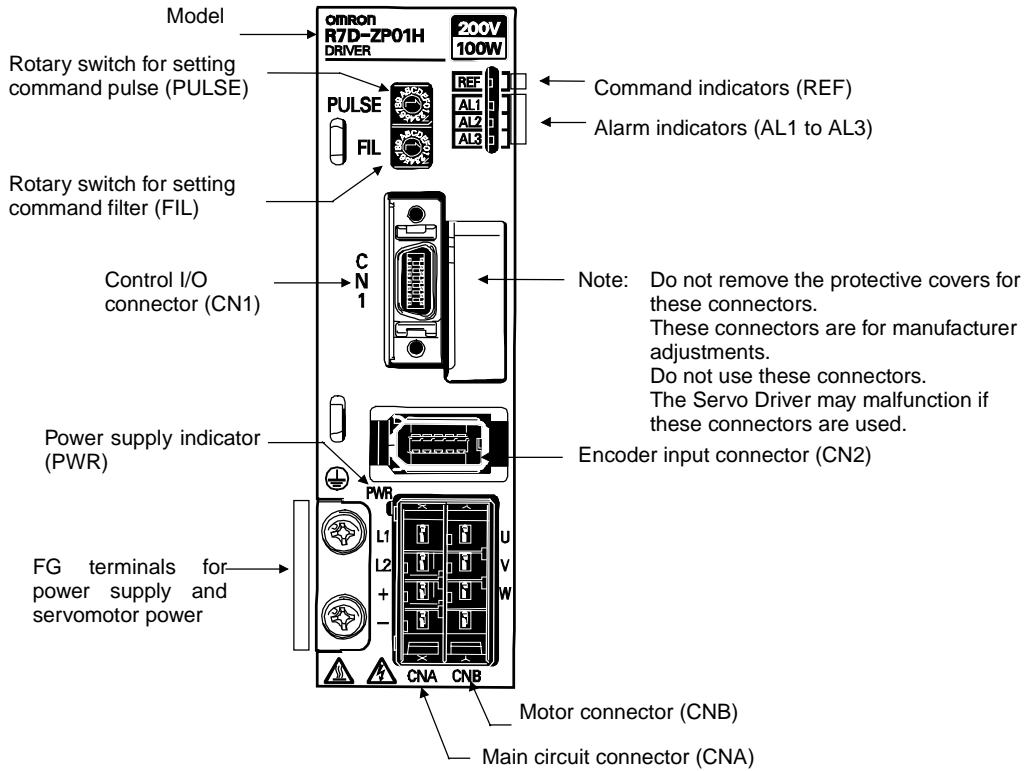

### ■ Rotary Switch for Setting Command Pulse (PULSE)

Always turn OFF the power supply before setting the rotary switch. (The switch is factory-set to 0.)

Setting	Command pulse resolution	Command pulse connection method	Command pulse type
0	1000	Open collector or line driver	CW+CCW, positive logic
1	2500		CW
2	5000	Line driver	CCW
3	10000		
4	1000	Open collector or line driver	CW+CCW, negative logic
5	2500		CW
6	5000	Line driver	CCW
7	10000		
8	1000	Open collector or line driver	Sign + pulse string, positive logic
9	2500		PULS
A	5000	Line driver	SIGN
B	10000		
C	1000	Open collector or line driver	Sign + pulse string, negative logic
D	2500		PULS
E	5000	Line driver	SIGN
F	10000		

### ■ Rotary Switch for Setting Command Filter (FIL)

This switch does not need to be set if the machine is not subject to vibration. (The switch is factory-set to 0.)

Filter setting (See note 1.)	Acceleration/deceleration time for STEP command (See note 3.)	Approx. time from end of command to end of positioning (settling time) (See note 2.)	Description
0	45 ms	100 to 200 ms	Smaller filter time constant (short positioning time) Larger filter time constant (longer positioning time with little vibration)
1	50 ms	110 to 220 ms	
2	60 ms	130 to 260 ms	
3	65 ms	150 to 300 ms	
4	70 ms	170 to 340 ms	
5	80 ms	200 to 400 ms	
6	85 ms	250 to 500 ms	
7	170 ms	500 to 1,000 ms	
8 to F	Do not set this switch to 8 to F.		

- Note 1. Increase the value of the filter setting if there is vibration when starting or stopping.  
 Note 2. The settling time depends on the commanded acceleration/deceleration, the rigidity of the machine motor drive, the encoder resolution, and other factors.  
 Note 3. Use the acceleration/deceleration times as a guideline for determining the Servomotor capacity that can be driven when using STEP commands without commanded acceleration/deceleration.

### ■ Command Indicators (REF)

Indicator (See note.)	Power to motor	Command pulse
Lit orange.	OFF	None
Flashing orange.	OFF	Pulse being input.
Lit green.	ON	None
Flashing green.	ON	Pulse being input.

Note: The indicator stays lit (yellow) for 1 s when there is a deviation counter reset input.

### ■ Alarm Indicators (AL1/AL2/AL3)

Indicator status	Alarm	Indicator	Alarm
AL1 ■ AL2 ■ AL3 ■	Normal	AL1 □ AL2 ■ AL3 □	Overcurrent
AL1 □ AL2 ■ AL3 ■	Overspeed	AL1 ■ AL2 □ AL3 □	Servo Driver built-in fan is stopped
AL1 ■ AL2 □ AL3 ■	Overload	AL1 □ AL2 □ AL3 □	System error
AL1 □ AL2 □ AL3 ■	Encoder error	AL1 ▣ AL2 ▣ AL3 ▣ <small>Flashing at a constant interval.</small>	Rotary switch for setting command pulse (PULSE) has been changed.
AL1 ■ AL2 ■ AL3 □	Voltage error		

Lit: □ Not lit: ■ Flashing: ▣

# 1-4 System Block Diagrams

## 1-4-1 Pulse-string Input Servo Driver

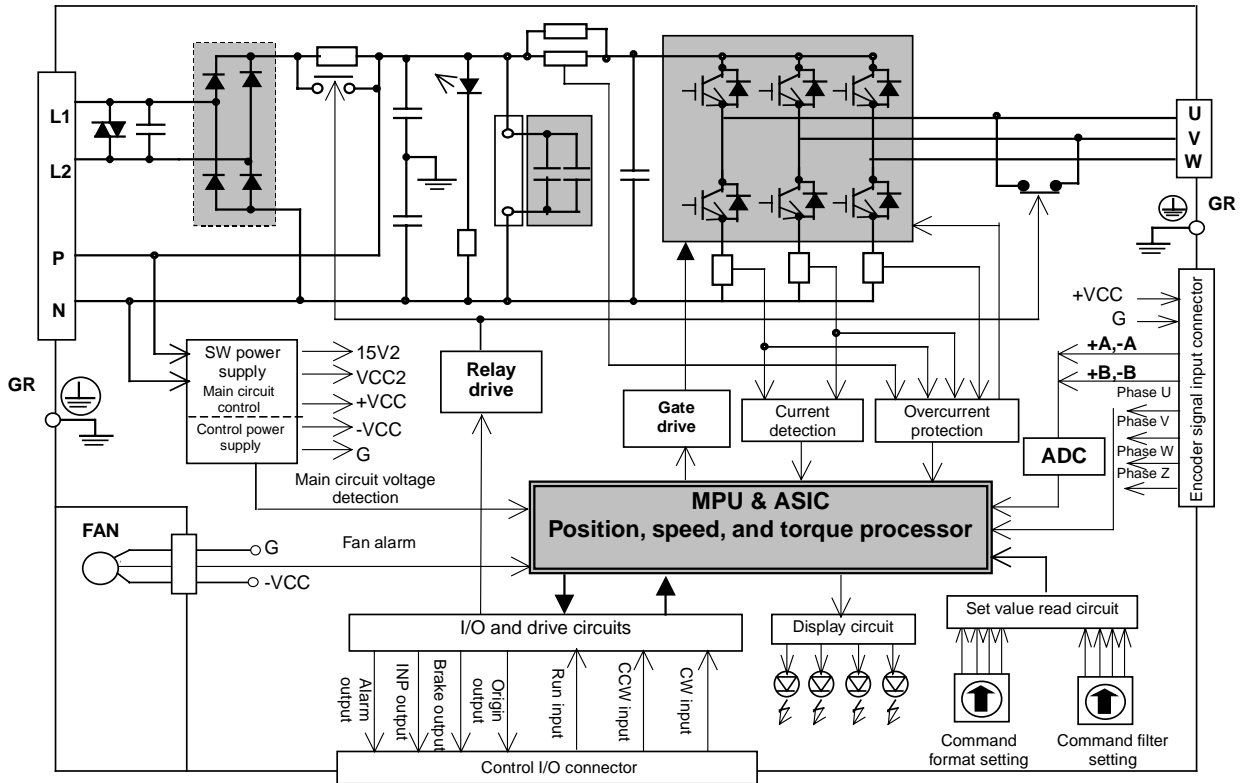

# 1-5 Applicable Standards

## 1-5-1 EC Directives

EC Directive	Product	Applicable standards	Comments
Low Voltage Directive	AC Servo Drivers	EN 50178	Safety requirements for electronic equipment for measurement, control, or laboratory use
	AC Servomotors	IEC 60034-1, -5, -8, and -9 EN 60034-1 and -9	Rotating electric machines
EMC Directive	AC Servo Drivers and AC Servomotors	EN 55011 Class A Group1	Limits and methods of measurement of radio disturbance of industrial, scientific, and medical radio-frequency equipment
		EN 61000-6-2	Electromagnetic compatibility (EMC): Immunity standard for industrial environments

Note: To conform to EMC Directives, the Units must be installed under the conditions described in 4-2-5 *Conforming to EMC Directives*.

## 1-5-2 UL and cUL Standards

Standard	Product	Applicable standards	File number	Comments
UL	AC Servo Drivers	UL 508C	E179149	Power Conversion Equipment
	AC Servomotors	UL 1004	E179189	Electric Motors
cUL	AC Servo Drivers	cUL C22.2 No.14	E179149	Industrial Control Equipment
	AC Servomotors	cUL C22.2 No.100	E179189	Motors and Generation Equipment



**1-5 Applicable Standards**  
1-5-2 UL and cUL Standards

## **Section 2**

# **Standard Models and Dimensions**

## 2-1 Standard Models

### 2-1-1 Servo Drivers

# 2-1 Standard Models

### 2-1-1 Servo Drivers

Specifications		Model
Pulse string input	100 W	R7D-ZP01H
	200 W	R7D-ZP02H
	400 W	R7D-ZP04H
	750 W	R7D-ZP08H

### 2-1-2 Servomotors

Specifications		Model
Without brake	100 W	R7M-Z10030-S1
	200 W	R7M-Z20030-S1
	400 W	R7M-Z40030-S1
	750 W	R7M-Z75030-S1
With brake	100 W	R7M-Z10030-BS1
	200 W	R7M-Z20030-BS1
	400 W	R7M-Z40030-BS1
	750 W	R7M-Z75030-BS1

### 2-1-3 Servo Driver-Servomotor Combinations

Rated output	Servomotor		Servo Driver
	Without brake	With brake	Pulse string input
100 W	R7M-Z10030-S1	R7M-Z10030-BS1	R7D-ZP01H
200 W	R7M-Z20030-S1	R7M-Z20030-BS1	R7D-ZP02H
400 W	R7M-Z40030-S1	R7M-Z40030-BS1	R7D-ZP04H
750 W	R7M-Z75030-S1	R7M-Z75030-BS1	R7D-ZP08H

Note: Only the Servomotor and Servo Driver combinations listed here can be used. Do not use other combinations.

## 2-1-4 Decelerators (Straight Shaft with Key)

### ■ Backlash: 3 Arcminutes Max.

Specifications		Model
Motor capacity	Gear ratio	
100 W	1/5	R7G-VRSFPB05B100
	1/9	R7G-VRSFPB09B100
	1/15	R7G-VRSFPB15B100
	1/25	R7G-VRSFPB25C100
200 W	1/5	R7G-VRSFPB05B200
	1/9	R7G-VRSFPB09C400
	1/15	R7G-VRSFPB15C400
	1/25	R7G-VRSFPB25C200
400 W	1/5	R7G-VRSFPB05C400
	1/9	R7G-VRSFPB09C400
	1/15	R7G-VRSFPB15C400
	1/25	R7G-VRSFPB25D400
750 W	1/5	R7G-VRSFPB05C750
	1/9	R7G-VRSFPB09D750
	1/15	R7G-VRSFPB15D750
	1/25	R7G-VRSFPB25E750

### ■ Backlash: 45 Arcminutes Max.

Specifications		Model
Motor capacity	Gear ratio	
100 W	1/5	R7G-RGSF05B100
	1/9	R7G-RGSF09B100
	1/15	R7G-RGSF15B100
200 W	1/5	R7G-RGSF05B200
	1/9	R7G-RGSF09C400
	1/15	R7G-RGSF15C400
400 W	1/5	R7G-RGSF05C400
	1/9	R7G-RGSF09C400
	1/15	R7G-RGSF15C400

## 2-1-5 Accessories and Cables

### ■ Control Cables (for CN1)

Specifications		Model
General-purpose Control Cables	1 m	R7A-CPZ001S
	2 m	R7A-CPZ002S

### ■ Servomotor Power Cables (for CNB)

Specifications		Model
Power Cables for Servomotors without Brakes (connector attached)	3 m	R7A-CAZ003S
	5 m	R7A-CAZ005S
	10 m	R7A-CAZ010S
Cable Only (in 1-m increments)		R7A-CAZ001
Power Cables for Servomotors with Brakes (connector attached)	3 m	R7A-CAZ003B
	5 m	R7A-CAZ005B
	10 m	R7A-CAZ010B
Cable Only (in 1-m increments)		R7A-CAZ01B

### ■ Encoder Cables (for CN2)

Specifications		Model
Encoder Cables (connector attached)	3 m	R7A-CRZ003C
	5 m	R7A-CRZ005C
	10 m	R7A-CRZ010C
Cable Only (in 1-m increments)		R7A-CRZ001

### ■ Connectors

Specifications	Model
Main Circuit Connector (CNA) with Ejector Levers	R7A-CNZ01P
Servomotor Connector (CNB)	R7A-CNZ01A
Control Input Connector (CN1)	R7A-CNA01R
Encoder Input Connector (CN2)	R7A-CNZ01R
Servomotor Connector for Encoder Cable	R7A-CNZ02R
Servomotor Connector for Servomotor Power Cable	R7A-CNZ02A

### ■ Regeneration Resistance Unit

Specifications	Model
Regeneration current: 8 A Internal resistance: 50 Ω, 12 W	R88A-RG08UA

### ■ External Regeneration Resistor

Specifications	Model
Regeneration capacity: 70 W, 47 Ω	R88A-RR22047S

### ■ AC Reactors

Specifications	Model
R7D-ZP01H	R88A-PX5052
R7D-ZP02H	R88A-PX5053
R7D-ZP04H	R88A-PX5054
R7D-ZP08H	R88A-PX5056

# 2-2 External and Mounted Dimensions

## 2-2-1 Servo Drivers

### ■ R7D-ZP01H/-ZP02H (100 W/200 W)

Mounting Hole Dimensions

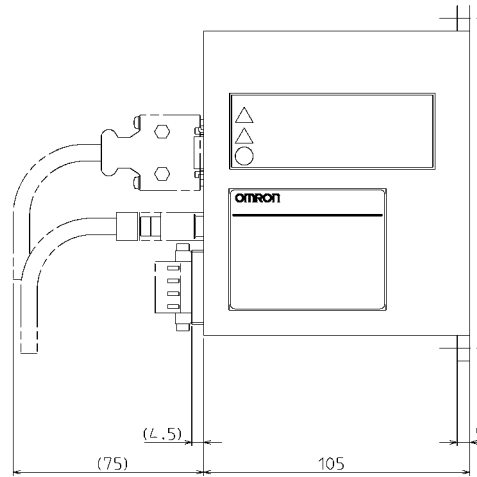
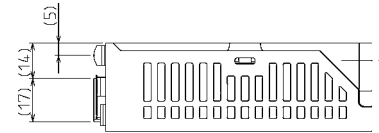
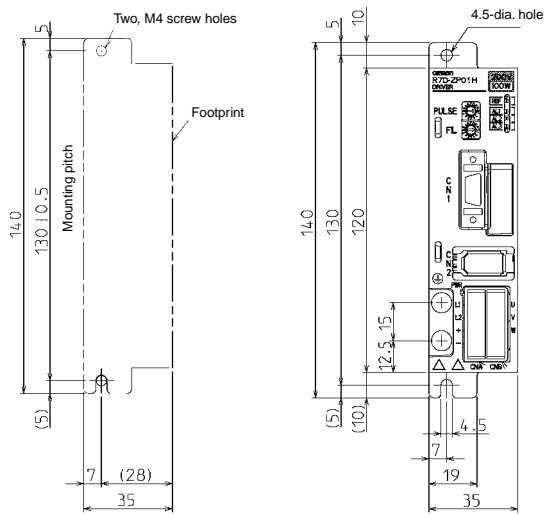

### ■ R7D-ZP04H (400 W)

Mounting Hole Dimensions

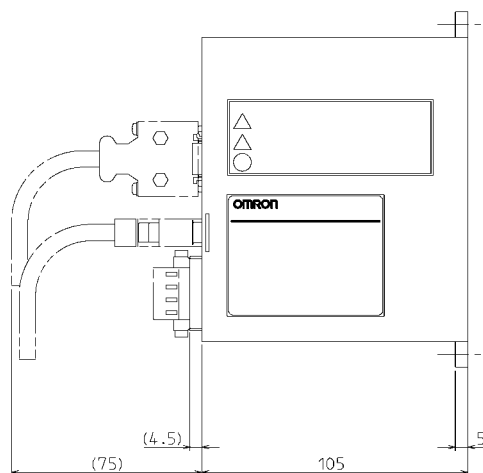
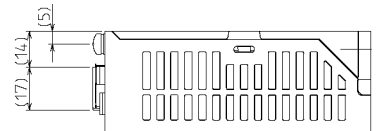
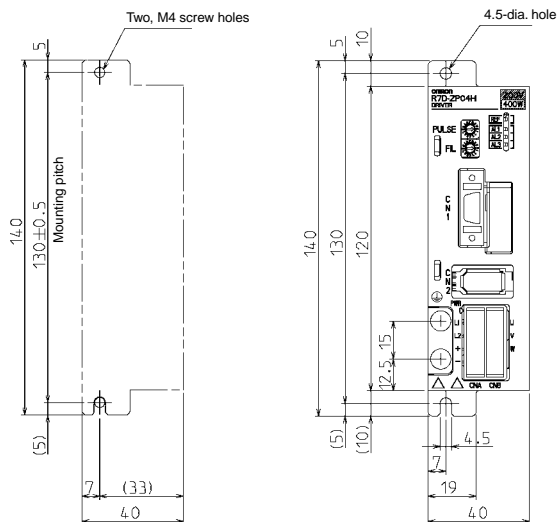

## 2-2 External and Mounted Dimensions

### 2-2-1 Servo Drivers

#### ■ R7D-ZP08H (750 W)

Mounting Hole Dimensions

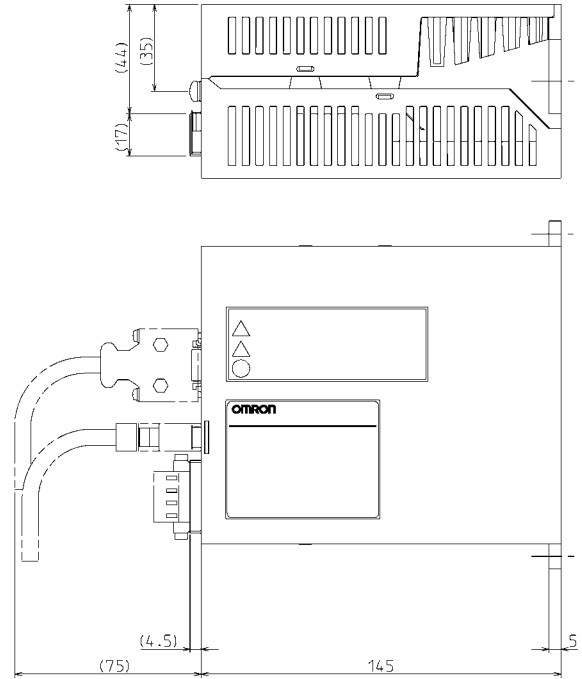
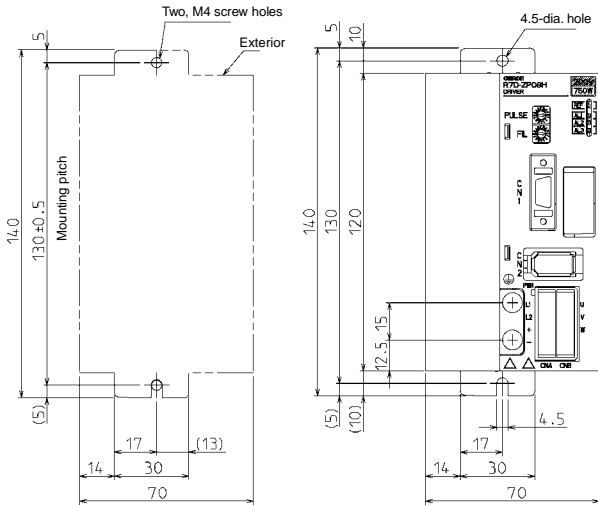

2-2-2 Servomotors

■ 100-W Servomotor without a Brake

- R7M-Z10030-S1

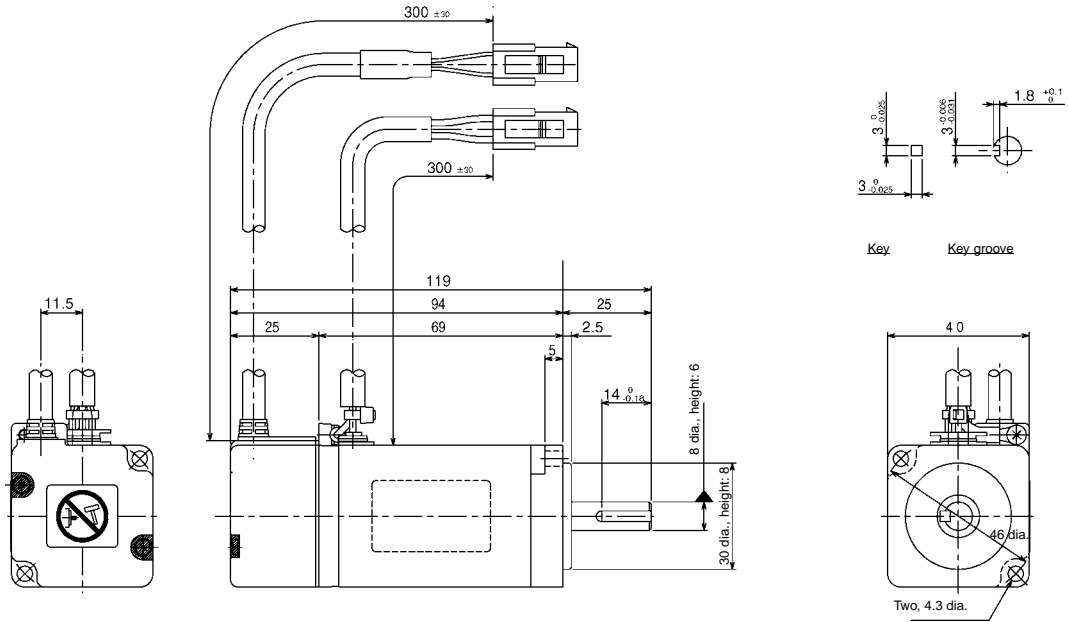

■ 100-W Servomotor with Brake

- R7M-Z10030-BS1

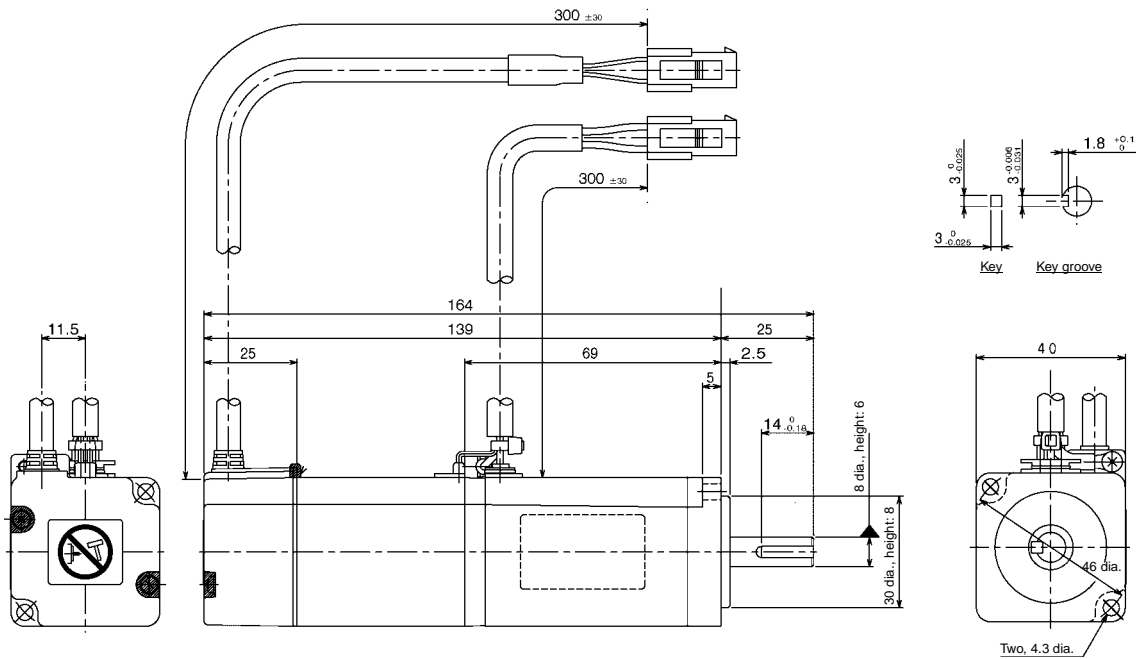



## 2-2 External and Mounted Dimensions

### 2-2-2 Servomotors

#### ■ 200-W/400-W/750-W Servomotors without Brakes

- R7M-Z20030-S1/Z40030-S1/Z75030-S1

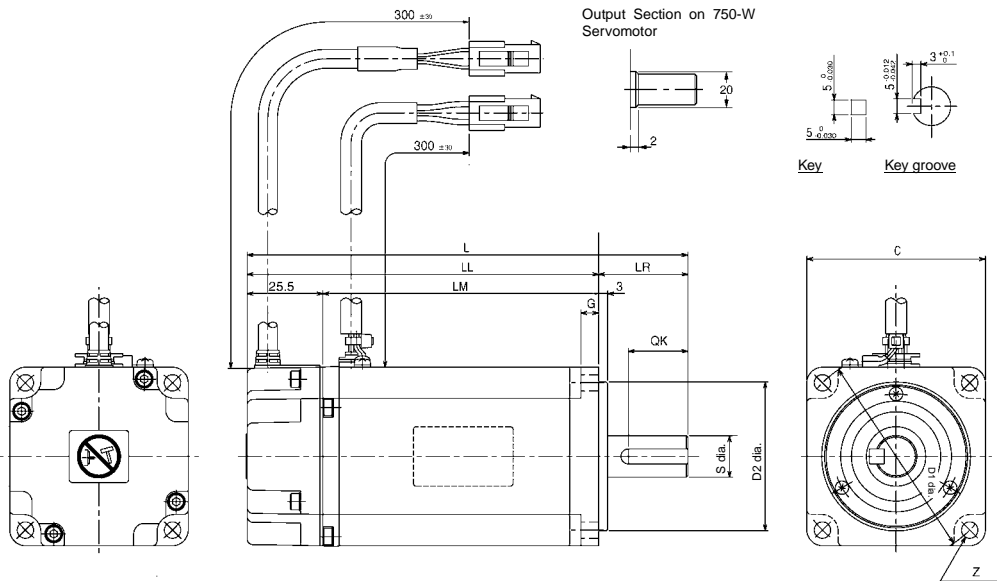

Model	L (mm)	LL (mm)	LM (mm)	LR (mm)	C (mm)	D1 (mm)	D2 (mm)	G (mm)	Z (mm)	S (mm)	QK (mm)	Output (w)
R7M-Z20030-S1	125.5	95.5	70	30	60	70	50h8	6	Four, 5.5 dia.	14h6	20	200
R7M-Z40030-S1	148.5	118.5	93	30	60	70	50h8	6	Four, 5.5 dia.	14h6	20	400
R7M-Z75030-S1	173	133	107.5	40	80	90	70h8	8	Four, 7 dia.	16h6	30	750

#### ■ 200-W/400-W/750-W Servomotors with Brakes

- R7M-Z20030-BS1/Z40030-BS1/Z75030-BS1

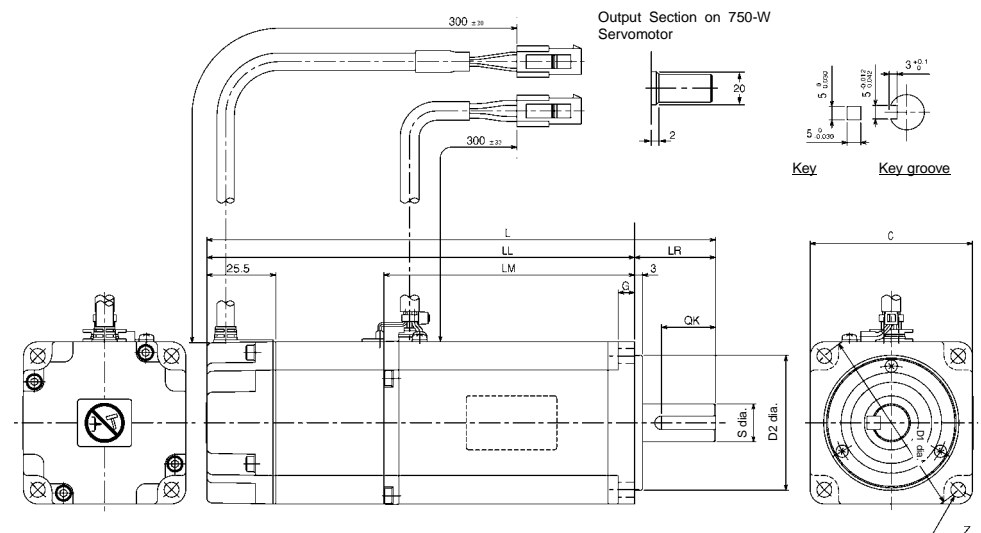

Model	L (mm)	LL (mm)	LM (mm)	LR (mm)	C (mm)	D1 (mm)	D2 (mm)	G (mm)	Z (mm)	S (mm)	QK (mm)	Output (w)
R7M-Z20030-BS1	165.5	135.5	70	30	60	70	50h8	6	Four, 5.5 dia.	14h6	20	200
R7M-Z40030-BS1	188.5	158.5	93	30	60	70	50h8	6	Four, 5.5 dia.	14h6	20	400
R7M-Z75030-BS1	216	176	107.5	40	80	90	70h8	8	Four, 7 dia.	16h6	30	750

### 2-2-3 Decelerator Dimensions

■ Backlash: 3 Arcminutes Max.

Model			Dimensions (mm)																	Weight (kg)				
			LM	LR	C1	C2	D1	D2	D3	D4	E3	F	G	S	T	Z1	Z2	AT(See note.)	l		Key dimensions			
																					QK	b	h	t1
100 W	1/5	R7G-VRSFPB05B100	67.5	32	52	40	46	60	50	45	10	3	6	12	20	M4	M5	M3	12	16	4	4	2.5	0.55
	1/9	R7G-VRSFPB09B100	67.5	32	52	40	46	60	50	45	10	3	6	12	20	M4	M5	M3	12	16	4	4	2.5	0.55
	1/15	R7G-VRSFPB15B100	78	32	52	40	46	60	50	45	10	3	6	12	20	M4	M5	M3	12	16	4	4	2.5	0.7
	1/25	R7G-VRSFPB25C100	92	50	78	40	46	90	70	62	17	3	6	19	30	M4	M6	M3	20	22	6	6	3.5	1.7
200 W	1/5	R7G-VRSFPB05B200	72.5	32	52	60	70	60	50	45	10	3	10	12	20	M5	M5	M4	12	16	4	4	2.5	0.72
	1/9	R7G-VRSFPB09C400	89.5	50	78	60	70	90	70	62	17	3	8	19	30	M5	M6	M4	20	22	6	6	3.5	1.7
	1/15	R7G-VRSFPB15C400	100	50	78	60	70	90	70	62	17	3	8	19	30	M5	M6	M4	20	22	6	6	3.5	2.1
	1/25	R7G-VRSFPB25C200	100	50	78	60	70	90	70	62	17	3	8	19	30	M5	M6	M4	20	22	6	6	3.5	2.1
400 W	1/5	R7G-VRSFPB05C400	89.5	50	78	60	70	90	70	62	17	3	8	19	30	M5	M6	M4	20	22	6	6	3.5	1.7
	1/9	R7G-VRSFPB09C400	89.5	50	78	60	70	90	70	62	17	3	8	19	30	M5	M6	M4	20	22	6	6	3.5	1.7
	1/15	R7G-VRSFPB15C400	100	50	78	60	70	90	70	62	17	3	8	19	30	M5	M6	M4	20	22	6	6	3.5	2.1
	1/25	R7G-VRSFPB25D400	104	61	98	60	70	115	90	75	18	5	8	24	40	M5	M8	M4	20	30	8	7	4	3.2
750 W	1/5	R7G-VRSFPB05C750	93.5	50	78	80	90	90	70	62	17	3	10	19	30	M6	M6	M4	20	22	6	6	3.5	2.1
	1/9	R7G-VRSFPB09D750	97.5	61	98	80	90	115	90	75	18	5	10	24	40	M6	M8	M4	20	30	8	7	4	3.4
	1/15	R7G-VRSFPB15D750	110	61	98	80	90	115	90	75	18	5	10	24	40	M6	M8	M4	20	30	8	7	4	3.8
	1/25	R7G-VRSFPB25E750	135	75	125	80	90	135	110	98	17	5	10	32	55	M6	M10	M4	20	45	10	8	5	7.2

Note: AT is the size of the set bolt.

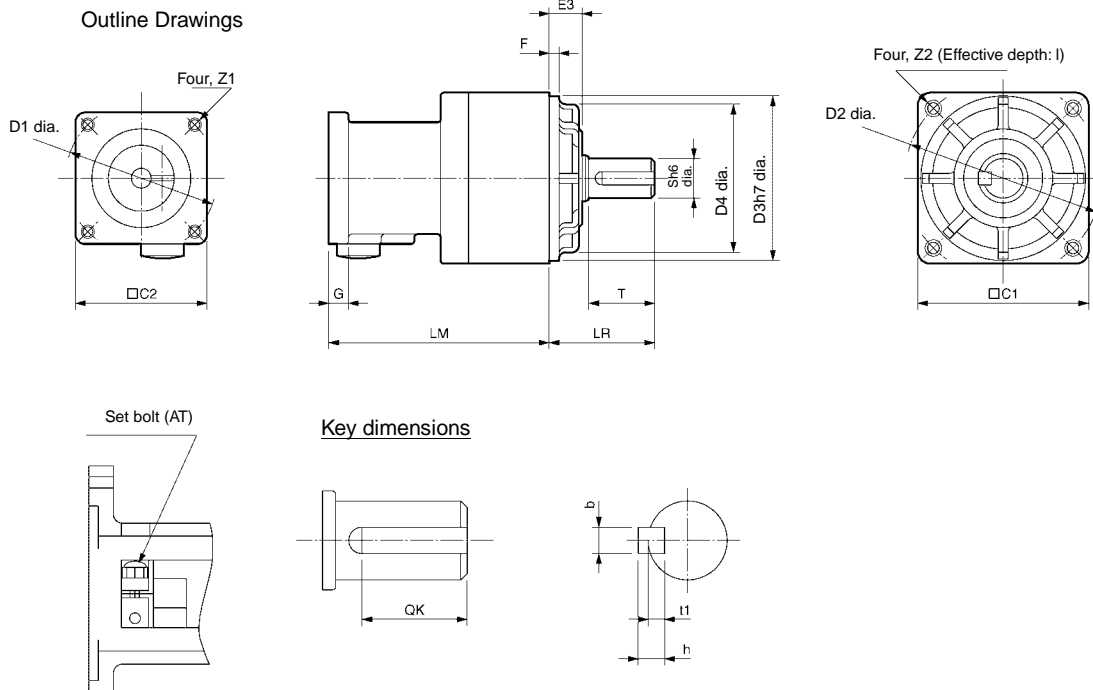

## 2-2 External and Mounted Dimensions

### 2-2-3 Decelerator Dimensions

#### ■ Backlash: 45 Arcminutes Max.

Model			Dimensions (mm)																	Weight (kg)				
			LM	LR	C1	C2	D1	D2	D3	D4	E3	F	G	S	T	Z1	Z2	AT	l		Key dimensions			
																					QK	b	h	t1
100 W	1/5	R7G-RGSF05B100	67.5	32	52	40	46	60	50	45	10	3	6	12	20	M4	M5	M3	12	16	4	4	2.5	0.55
	1/9	R7G-RGSF09B100	67.5	32	52	40	46	60	50	45	10	3	6	12	20	M4	M5	M3	12	16	4	4	2.5	0.55
	1/15	R7G-RGSF15B100	78	32	52	40	46	60	50	45	10	3	6	12	20	M4	M5	M3	12	16	4	4	2.5	0.7
200 W	1/5	R7G-RGSF05B200	72.5	32	52	60	70	60	50	45	10	3	10	12	20	M5	M5	M4	12	16	4	4	2.5	0.72
	1/9	R7G-RGSF09C400	89.5	50	78	60	70	90	70	62	17	3	8	19	30	M5	M6	M4	20	22	6	6	3.5	1.7
	1/15	R7G-RGSF15C400	100	50	78	60	70	90	70	62	17	3	8	19	30	M5	M6	M4	20	22	6	6	3.5	2.1
400 W	1/5	R7G-RGSF05C400	89.5	50	78	60	70	90	70	62	17	3	8	19	30	M5	M6	M4	20	22	6	6	3.5	1.7
	1/9	R7G-RGSF09C400	89.5	50	78	60	70	90	70	62	17	3	8	19	30	M5	M6	M4	20	22	6	6	3.5	1.7
	1/15	R7G-RGSF15C400	100	50	78	60	70	90	70	62	17	3	8	19	30	M5	M6	M4	20	22	6	6	3.5	2.1

Note: AT is the size of the set bolt.

#### Outline Drawings

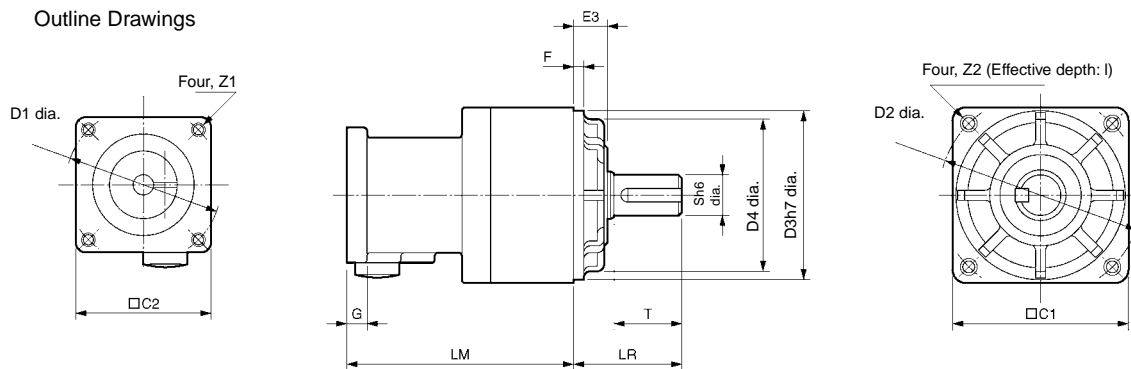

#### Set bolt (AT)

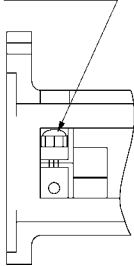

#### Key dimensions

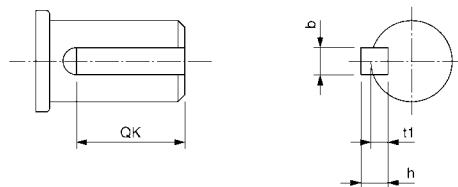

**Section 3**

**Specifications**

### 3-1 Servo Driver Specifications

#### 3-1-1 General Specifications

# 3-1 Servo Driver Specifications

Select the Servo Driver in combination with the Servomotor being used. (For details, refer to 2-1-3 Servo Driver-Servomotor Combinations.)

### 3-1-1 General Specifications

Item		Specifications	
Ambient operating temperature		0 to 55°C	
Ambient operating humidity		90% max. (with no condensation)	
Ambient storage temperature		-20 to 70°C	
Ambient storage humidity		90% max. (with no condensation)	
Storage and operating atmosphere		No corrosive gasses, no dust, no iron dust, no exposure to moisture or cutting oil	
Vibration resistance		10 to 55 Hz in X, Y, and Z directions with 0.1-mm double amplitude; acceleration: 4.9 m/s <sup>2</sup> max.	
Impact resistance		Acceleration 19.6 m/s <sup>2</sup> max., in X, Y, and Z directions, three times	
Insulation resistance		Between power supply/power line terminals and frame ground: 0.5 MΩ min. (at 500 V DC)	
Dielectric strength		Between power supply/power line terminals and frame ground: 1,500 V AC for 1 min at 50/60 Hz Between each control signal and frame ground: 500 V AC for 1 min	
Degree of protection		Built into panel (IP10).	
International standards	EC Directives	EMC Directive	EN 55011 Class A Group 1 EN 61000-6-2
		Low Voltage Directive	EN 50178
	UL standards		UL 508C
	cUL standards		cUL C22.2 No.14

- Note
1. The above items reflect individual evaluation testing. The results may differ under compound conditions.
  2. Depending on the operating conditions, some Servo Driver parts will require maintenance. Refer to 6-5 *Periodic Maintenance* in the *User's Manual* for details.
  3. The service life of the Servo Driver is 50,000 hours at an average ambient temperature of 40°C at 80% of the rated torque (excluding axial-flow fan).



# WARNING



**WARNING** Never perform withstand-voltage or other megameter tests on the Servo Driver.

### 3-1-2 Characteristics

#### ■ Control Specifications

Item		R7D-			
		ZP01H	ZP02H	ZP04H	ZP08H
Continuous output current (rms)		0.84 A	1.1 A	2.0 A	3.7 A
Momentary maximum output current (rms)		2.5 A	3.3 A	6.0 A	11.1 A
Input power supply (For main circuit and control circuit)		Single-phase 200 to 230 VAC (170 to 253 V), 50/60 Hz			
Heat generated	Main circuit	6 W	8 W	16 W	27 W
	Control circuit	8 W	8 W	8 W	8 W
Control method		All-digital servo			
Inverter method		IGBT-driven PWM method			
Maximum response frequency (command pulses)		750 kpps			
Weight		0.5 kg			1.0 kg
Applicable motor capacity		100 W	200 W	400 W	750 W
Applicable Servomotors (R7M-)		Z10030-S1	Z20030-S1	Z40030-S1	Z75030-S1

### 3-1-3 Main Circuit and Servomotor Connector Specifications (CNA and CNB)

#### ■ R7A-CNZ01P (CNA) Main Circuit Connector Specifications

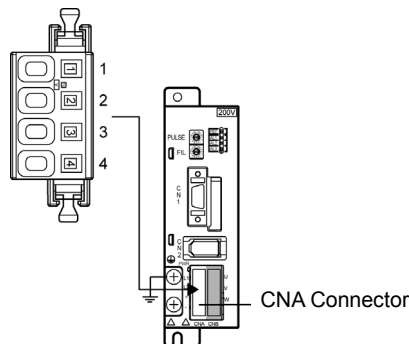

#### ● Main Circuit Connector (CNA) Pin Arrangement

Signal No.	Signal	Function	Condition
1	L1	Main circuits power supply input	Single-phase 200/230 V AC (170 to 253 V AC) 50/60 Hz
2	L2		
3	+	Regeneration Resistance Unit connection terminals	If regenerative energy is high, connect a Regeneration Resistance Unit between P and N.
4	-		
⊕	⊕	Frame ground	This is the ground terminal. Ground to a minimum of 100 Ω (class D, class 3).

### 3-1 Servo Driver Specifications

#### 3-1-3 Main Circuit and Servomotor Connector Specifications (CNA and CNB)

#### ■ R7A-CNZ01A (CNB) Servomotor Connector Specifications

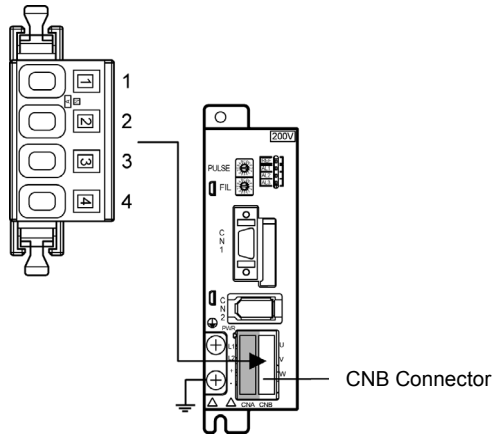

#### ● Servomotor Connector (CNB) Pin Arrangement

Pin No.	Terminal label	Name	Function	
1	U	Servomotor connection Terminals	Red	These are the output terminals to the Servomotor. Be careful to wire them correctly.
2	V		White	
3	W		Blue	
4		---	Do not connect anything to this terminal.	
⊕	⊕	Frame ground	Green/Yellow	Connect the Servomotor FG terminal.

### 3-1-4 Control I/O Specifications (CN1)

#### ■ Control I/O Signal Connections and External Signal Processing

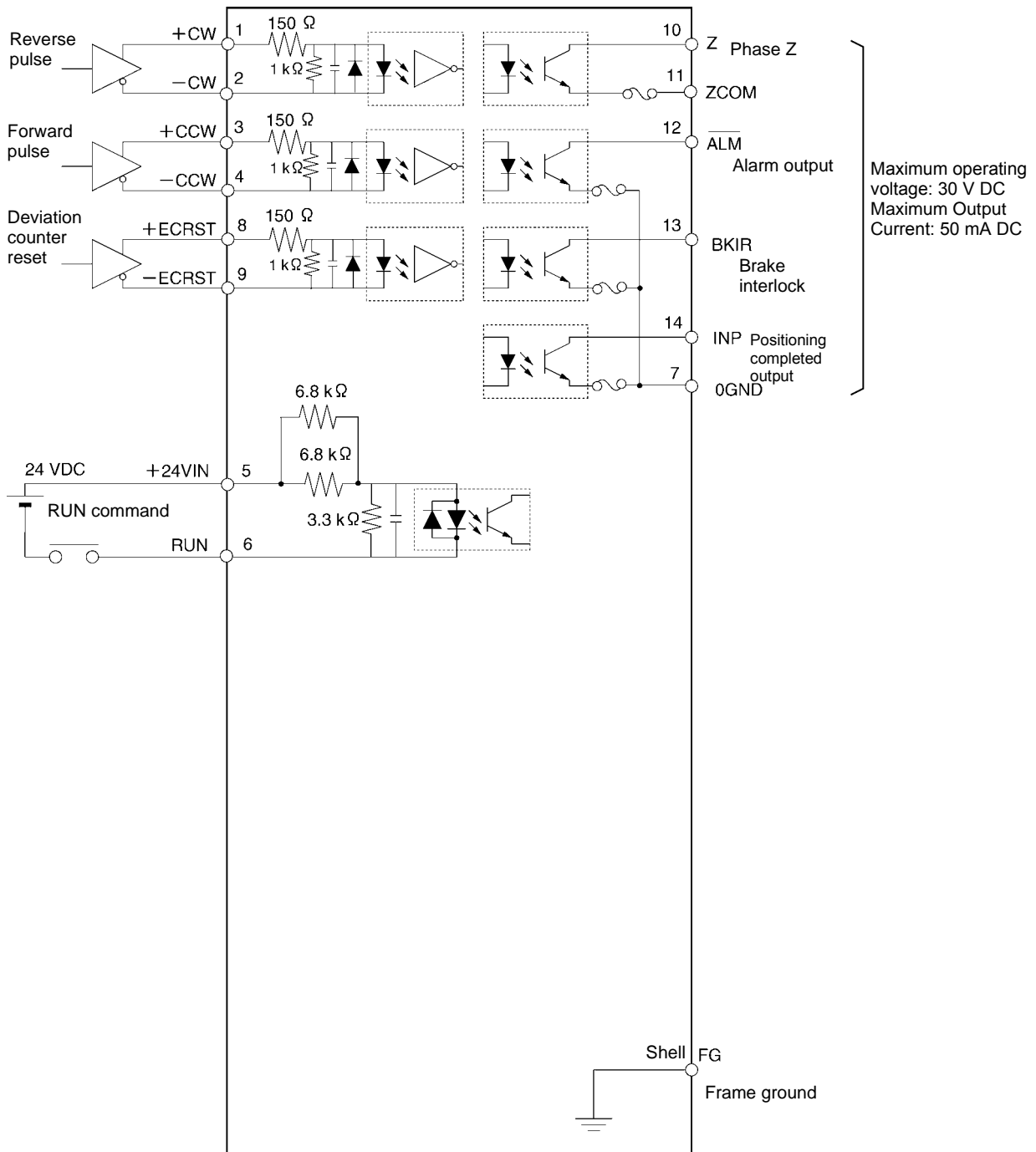



### 3-1 Servo Driver Specifications

#### 3-1-4 Control I/O Specifications (CN1)

#### ■ Control I/O Signals

##### ● CN1 Control Inputs

Pin No.	Signal name	Function	Function/Interface
1	+CW/PULS	Reverse pulses, feed pulses	Pulse string input terminals for position commands. Line-driver input: Maximum response frequency: 750 kpps Open-collector input: Maximum response frequency: 187.5 kpps Note: Either forward and reverse pulses (CW/CCW), or feed pulses and direction signal (PULS/SIGN) can be selected using the rotary switch for setting command pulses, located on the front of the Unit.
2	-CW/PULS		
3	+CCW/SIGN	Forward pulses, phase difference signals	
4	-CCW/SIGN		
5	+24VIN	+24-V power supply input for control DC	Power supply input terminal (+24 V DC) for sequence inputs (pin 6).
6	RUN	RUN command input	ON: Servo ON (Starts power to Servomotor.)
8	+ECRST	Deviation counter reset	ON: Pulse commands prohibited and deviation counter cleared. Note: Input for at least 20 $\mu$ s.
9	-ECRST		

##### ● CN1 Control Outputs

Pin No.	Signal name	Function	Function/Interface
10	Z	Phase Z output	Outputs the Encoder's phase Z. (1 pulse/revolution) Note: Use the rising edge of the ON signal.
11	ZCOM		
12	$\overline{\text{ALM}}$	Alarm output	When the Servo Driver generates an alarm, the output turns OFF. Note: OFF for approx. 2 s after the power is turned ON.
13	BKIR	Brake interlock output	Outputs the holding brake timing signals. Release the holding brake when this signal is ON.
14	INP	Positioning completed output	ON when the position deviation is within $\pm 10$ pulses.
7	0GND	Output ground common	Ground common for sequence outputs (pins 12, 13 and 14).

Note: An open-collector output interface is used for sequence outputs (maximum operating voltage: 30 V DC; maximum output current: 50 mA).

#### ■ CN1: Pin Arrangement

Pin No.	Signal name	Function	Pin No.	Signal name	Function
1	+CW/PULS	+ reverse pulse, + feed pulse	8	+ECRST	+ deviation counter reset
2	-CW/PULS	- feed pulse, - reverse pulse	9	-ECRST	- deviation counter reset
3	+CCW/SIGN	+ forward pulse, + direction signal	10	Z	Encoder phase Z output
4	-CCW/SIGN	- forward pulse, - direction signal	11	ZCOM	Phase Z output ground
5	+24VIN	Control DC +24-V input	12	$\overline{\text{ALM}}$	Alarm output
6	RUN	RUN command input	13	BKIR	Brake interlock output
7	0GND	Output ground common	14	INP	Positioning completed output

■ **CN1 Connectors (14P)**

- Soldered Connectors

Name	Model	Manufacturer
Cable plug	10114-3000VE	Sumitomo 3M
Cable case (shell kit)	10314-52A0-008	

**3-1-5 Control Input Circuits**

■ **Position Command Pulse Inputs and Deviation Counter Reset Inputs**

- Line Driver Input

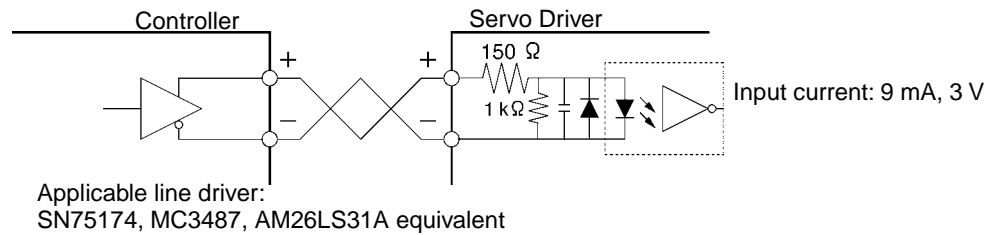

- Open Collector Input

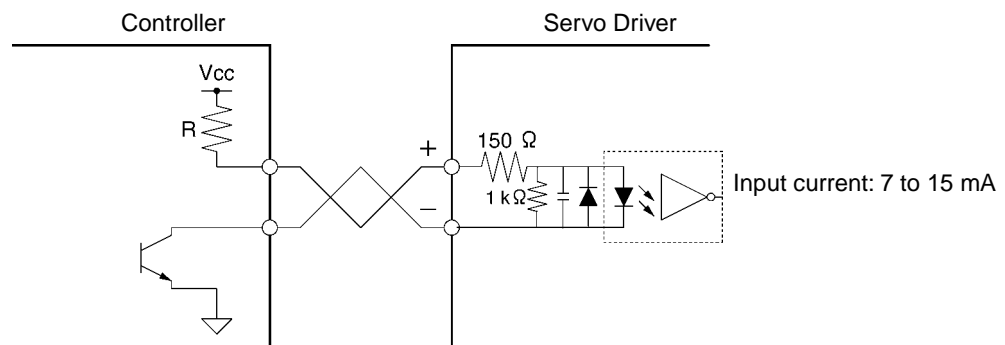

Note: Select a value for resistance R so that the input current will be from 7 to 15 mA.

Vcc	R
24 V	1.6 to 2.2 kΩ
12 V	750 to 1 kΩ
5 V	180 Ω

### 3-1 Servo Driver Specifications

#### 3-1-6 Control Input Details

##### ■ Sequence Inputs

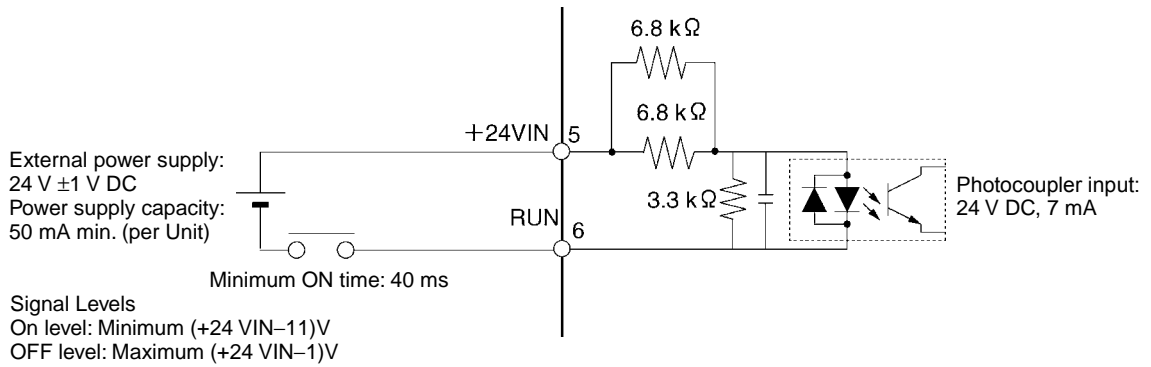

### 3-1-6 Control Input Details

#### ■ Feed Pulse/Direction Signal, Reverse Pulse/Forward Pulse

CN1 Pin Numbers

CN1 pin 1:

+Reverse Pulse (+CW), +Feed Pulse (+PULS)

CN1 pin 2:

-Reverse Pulse (-CW), -Feed Pulse (-PULS)

CN1 pin 3:

+Direction Signal (+SIGN), +Forward Pulse (+CCW)

CN1 pin 4:

-Direction Signal (-SIGN), -Forward Pulse (-CCW)

#### ● Signal Functions

The functions of these signals depend on the setting of the command pulse rotary switch (PULSE) on the front of the Servo Driver. Turn OFF the Servo Driver's power before setting the PULSE Switch. The factory setting is 0.

Setting	Command pulse resolution	Command pulse connection method	Command pulse type
0	1000	Open collector or line driver	CW + CCW, positive logic
1	2500		CW
2	5000		CCW
3	10000	Line driver	
4	1000	Open collector or line driver	CW + CCW, negative logic
5	2500		CW
6	5000		CCW
7	10000	Line driver	
8	1000	Open collector or line driver	Sign + pulse string, positive logic
9	2500		PULS
A	5000		SIGN
B	10000	Line driver	
C	1000	Open collector or line driver	Sign + pulse string, negative logic
D	2500		PULS
E	5000		SIGN
F	10000	Line driver	

- Command Pulse Timing

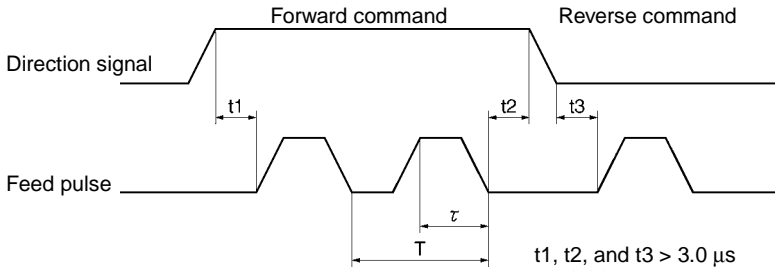
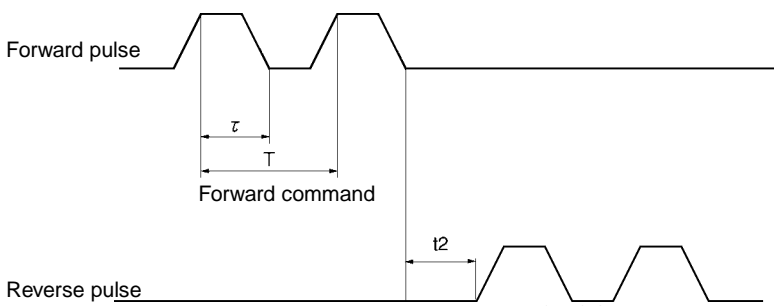
Command Pulse Mode	Timing details
<p>Feed pulse and direction signal</p> <p>Maximum input frequency Line driver: 750 kpps Open collector: 187.5 kpps</p>	 <p><math>t_1, t_2, \text{ and } t_3 &gt; 3.0 \mu\text{s}</math>  <math>\tau \geq 0.66 \mu\text{s}</math>  <math>T \geq 1.33 \mu\text{s}</math>  <math>(\tau / T) \times 100 \leq 50 (\%)</math></p>
<p>Reverse and forward pulses</p> <p>Maximum input frequency Line driver: 750 kpps Open collector: 187.5 kpps</p>	 <p><math>t_2 &gt; 3.0 \mu\text{s}</math>  <math>\tau \geq 0.66 \mu\text{s}</math>  <math>T \geq 1.33 \mu\text{s}</math>  <math>(\tau / T) \times 100 \leq 50 (\%)</math></p>

- Deviation Counter Reset (ECRST)

The CN1 connector input pins are as follows:

- +Deviation Counter Reset (8: +ECRST)
- Deviation Counter Reset (9: -ECRST)

- Functions

- The value of the deviation counter will be reset when the deviation counter reset signal turns ON and the position loop will be disabled.
- Input the reset signal for 20  $\mu\text{s}$  minimum. The counter will not be reset if the signal is too short.

- RUN Command Input (RUN)

RUN Command Input (pin 6: RUN)

- Functions

This is the input that turns ON the power drive circuit for the main circuit of the Servo Driver. If this signal is not input (i.e., servo-OFF status), the Servomotor cannot operate except for JOG operations.

### 3-1 Servo Driver Specifications

#### 3-1-7 Control Output Circuits

### 3-1-7 Control Output Circuits

#### ■ Phase Z Output

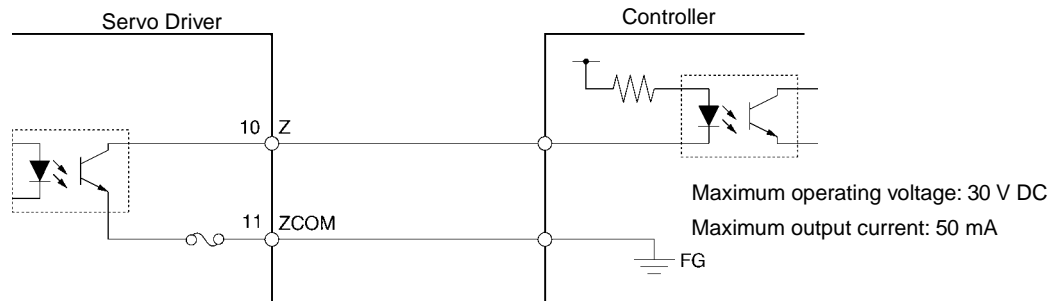

#### ■ Sequence and Alarm Outputs

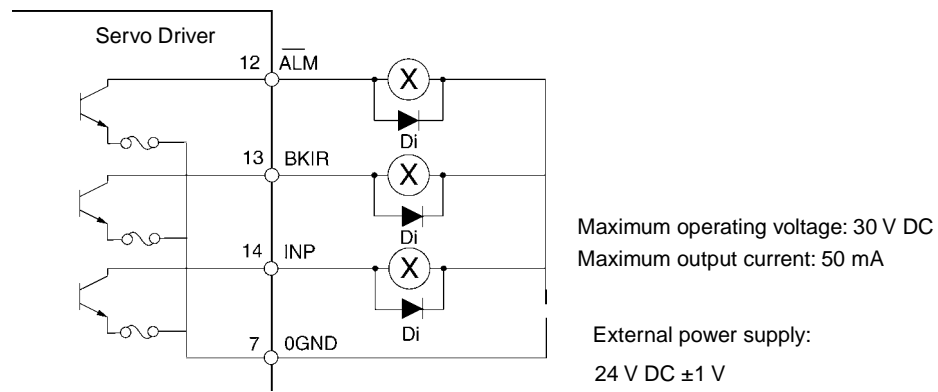

Di: Diode for preventing surge voltage (Use speed diodes.)

### 3-1-8 Control Output Details

#### ■ Control Output Sequence

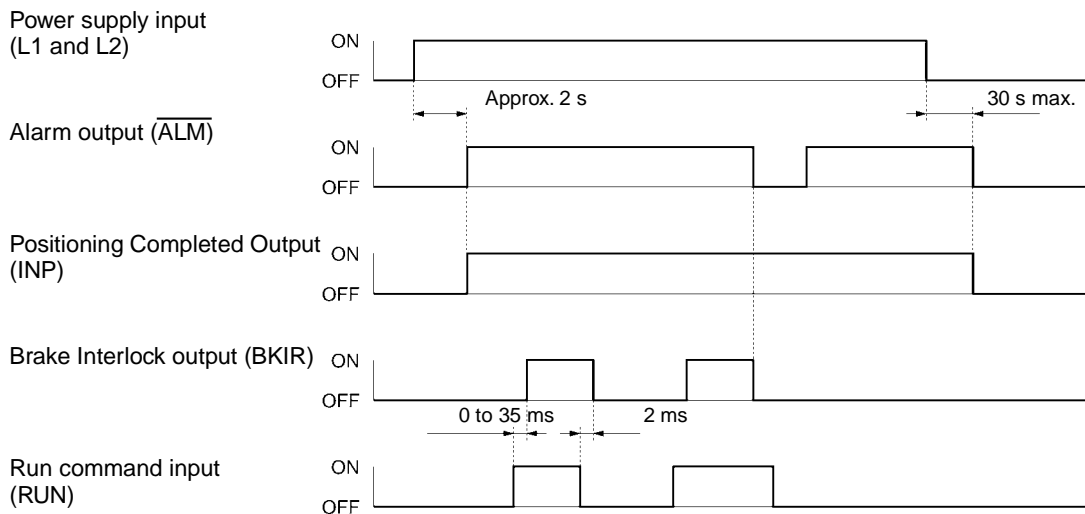

■ **Phase Z Output (Z)**

The following CN1 connector pins are used for the phase Z output.

Pin No. 10: Phase Z output (Z)

Pin No. 11: Phase Z output ground (ZCOM)

- Function
  - The Encoder phase Z is output.
  - One pulse is output for each rotation.

■ **Alarm Output ( $\overline{ALM}$ )**

- Pin No.12: Alarm Output ( $\overline{ALM}$ )

- Function
  - The alarm output is turned OFF when the Servo Driver detects an error.
  - This output is OFF at startup and turns ON when the initial processing has been completed. (Approx. 2 s is required for initial processing.)

■ **Brake Interlock Output (BKIR)**

Pin No.13: Brake Interlock output (BKIR)

- Function
  - The external brake timing signal is output.

■ **Positioning Completed Output (INP)**

Pin No.14: Positioning Completed Output (INP)

- Function
  - The INP signal turns ON when the number of accumulated pulses in the deviation counter is less than 10.

**3-1-9 Encoder Connector Specifications (CN2)**

Pin No.	Signal	Name	Function/interface
1	E5V	Encoder power supply, +5 V	Power supply output for the encoder 5 V, 70 mA
2	E0V	Encoder power supply, GND	
3	Phase A+	Encoder phase +A input	Differential sine-wave input
4	Phase A-	Encoder phase -A input	
5	Phase B+	Encoder phase +B input	Differential cos-wave input
6	Phase B-	Encoder phase -B input	
7	Phase Z	Encoder phase Z input	Open collector input
8	Phase U	Pole sensor phase U input	Open collector input
9	Phase V	Pole sensor phase V input	Open collector input
10	Phase W	Pole sensor phase W input	Open collector input
Shell	FG	Shield ground	Cable shield ground

■ **Connectors for CN2 (10-pin)**

- Soldered Connector

Name	Model	Maker
Plug, Cable, and Cover Set	54599-1005	Molex Japan Co.
Plug Connector	51593-1011	

**3-1 Servo Driver Specifications**  
3-1-9 Encoder Connector Specifications (CN2)

● Crimped (Solderless) Connector

Name	Model	Maker
Plug, Cable, and Cover Set	54559-1005	Molex Japan Co.
Plug Housing	51209-1001	
Crimp Terminal	59351-8187 (Loose wire)	
Crimping Tool	57401-5300	

## 3-2 Servomotor Specifications

Select a Servomotor based on the mechanical system's load conditions and the installation environment. There are various options available on the Servomotors, such as brakes.

### 3-2-1 General Specifications

Item		Specifications	
Ambient operating temperature		0 to 40°C	
Ambient operating humidity		20% to 80% (with no condensation)	
Ambient storage temperature		-20 to 60°C	
Ambient storage humidity		20% to 80% (with no condensation)	
Storage and operating atmosphere		No corrosive gases	
Vibration resistance		10 to 2,500 Hz, with a 0.2-mm double amplitude or acceleration of 24.5 m/s <sup>2</sup> (whichever is smaller) in the X, Y, and Z directions	
Impact resistance		98 m/s <sup>2</sup> max. (twice in vertical direction)	
Insulation resistance		10 MΩ min. at 500 VDC between the power terminals and FG terminal	
Dielectric strength		1,500 VAC (50 or 60 Hz) for 1 minute between the power terminals and FG terminal	
Operating position		Any direction	
Insulation class		Type B	
Construction		Totally-enclosed, self-cooling	
Degree of protection		IP55 (excluding the through-shaft portion)	
Vibration class		V-15	
Mounting method		Flange-mounting	
International standards	EC Directives	EMC Directive	EN 550011 Class A, Group1 EN 61000-6-2
		Low Voltage Directive	IEC 60034-1, -5, -8, and -9 EN 60034-1 and -9
	UL standards		UL 1004
	cUL standards		cUL C22.2 No. 100

#### ■ Motor Rotation Directions

In this manual, the Servomotors rotation directions are defined as forward and reverse. Viewed from the end of the motor's output shaft, counterclockwise (CCW) rotation is forward and clockwise (CW) rotation is reverse.

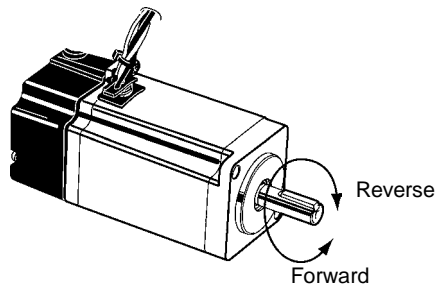



## 3-2 Servomotor Specifications

### 3-2-2 Characteristics

#### 3-2-2 Characteristics

Item		Unit	R7M- Z10030-S1	R7M- Z20030-S1	R7M- Z40030-S1	R7M- Z75030-S1	
Rated output (See note 1.)		W	100	200	400	750	
Rated torque (See note 1.)		N·m	0.318	0.637	1.27	2.39	
Rated rotation speed		r/min	3,000				
Max. momentary speed		r/min	4,500				
Max. momentary torque (See note 1.)		N·m	0.955	1.91	3.82	7.16	
Rated current (See note 1.)		A (rms)	0.84	1.1	2.0	3.7	
Max. momentary current (See note 1.)		A (rms)	2.5	3.3	6.0	11.1	
Rotor inertia		kg·m <sup>2</sup> (GD <sup>2</sup> /4)	$6.34 \times 10^{-6}$	$3.30 \times 10^{-5}$	$6.03 \times 10^{-5}$	$1.50 \times 10^{-4}$	
Power rate (See note 1.)		kW/s	16.0	12.3	26.7	38.1	
Allowable radial load (See notes 5 and 6.)		N	78	245	245	392	
Allowable thrust load (See note 5.)		N	54	74	74	147	
Weight	Without brake	kg	0.5	0.9	1.3	2.6	
	With brake	kg	0.7	1.5	1.9	3.5	
Radiation shield dimensions (material)			t6×□250 (Al)				
Applicable load inertia (See note 2.)		kg·m <sup>2</sup>	$6.0 \times 10^{-5}$ (9.5 ×)	$3.0 \times 10^{-4}$ (9.1 ×)	$5.0 \times 10^{-4}$ (8.3 ×)	$1.0 \times 10^{-3}$ (6.7 ×)	
Brake specifications	Brake inertia		kg·m <sup>2</sup> (GD <sup>2</sup> /4)	$7.54 \times 10^{-7}$	$6.4 \times 10^{-6}$	$6.4 \times 10^{-6}$	$1.71 \times 10^{-5}$
	Excitation voltage (See note 3.)		V	24 VDC ±10%			
	Power consumption (at 20°C)		W	6	7	7	7.7
	Current consumption (at 20°C)		A	0.25	0.29	0.29	0.32
	Static friction torque		N·m	0.318 min.	0.637 min.	1.27 min.	2.45 min.
	Attraction time (See note 4.)		ms	60 max.			
	Release time (See note 4.)		ms	30 max.	20 max.		
	Backlash		---	1° max.			
Rating		---	Continuous				
Applicable Servo Drivers (R7D-)		Pulse-train models	ZP01H	ZP02H	ZP04H	ZP08H	

Note 1. These are the values when the Servomotor is combined with a Servo Driver and the armature winding temperature is 100°C. Other values are at normal conditions (20°C, 65%). The momentary maximum torque shown above indicates the standard value.

- This is the value without an accessory, such as an external Regeneration Resistance Unit.
- The brakes operate when the circuit is open (i.e., they are released when voltage is applied).
- The operation time is the measured value (reference value) with a varistor installed as a surge suppressor.
- The allowable radial and thrust loads are the values determined for a service life of 20,000 hours at normal operating temperatures.
- The value indicated for the allowable radial load at the location shown in the following diagram.

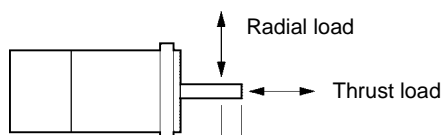

■ **Torque and Rotation Speed Characteristics**

The following graphs show the characteristics with a 3-m standard cable and a 200-V AC input.

**R7M-Z10030-S1**

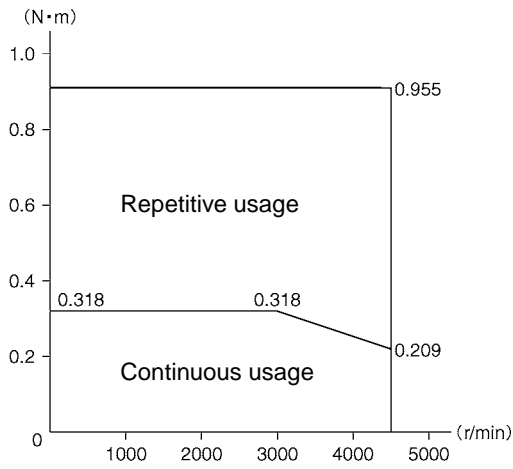

**R7M-Z20030-S1**

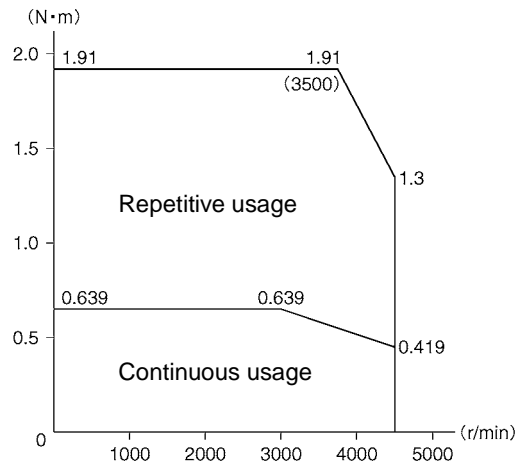

**R7M-Z40030-S1**

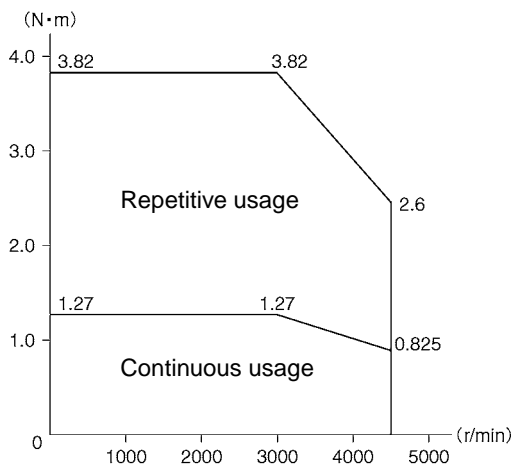

**R7M-Z75030-S1**

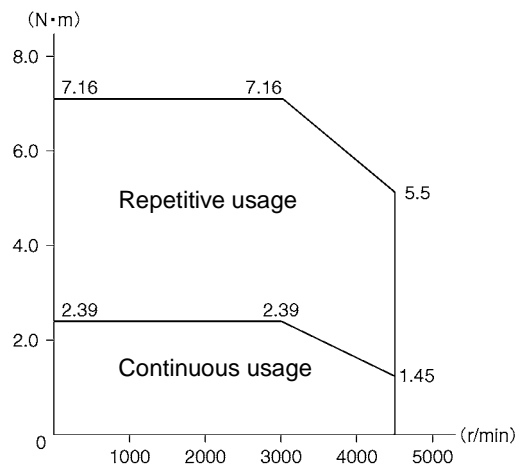

## 3-2 Servomotor Specifications

### 3-2-3 Encoder Specifications

#### ■ Temperature Characteristics of the Servomotor and Mechanical System

- SMARTSTEP Junior Servomotors use rare earth magnets (neodymium-iron magnets). The temperature coefficient for these magnets is approximately  $-0.13\%/^{\circ}\text{C}$ . As the temperature drops, the Servomotor's maximum momentary torque increases, and as the temperature rises, the Servomotor's maximum momentary torque decreases. The maximum momentary torque is about 4% higher at  $-10^{\circ}\text{C}$  compared to the normal temperature of  $20^{\circ}\text{C}$ . Conversely, the maximum momentary torque decreases about 8% when the Servomotor warms up to  $80^{\circ}\text{C}$  from the normal temperature of  $20^{\circ}\text{C}$ .
- Generally, when the temperature drops in a mechanical system, the friction torque and the load torque increase. For that reason, overloading may occur at low temperatures. In particular, in systems that use a Decelerator, the load torque at low temperatures may be nearly twice the load torque at normal temperatures. Check with a current monitor to see whether there is overloading at low temperatures. Also check operation at high temperatures to see whether there is abnormal Servomotor overheating or alarms.
- An increase in load friction torque visibly increases load inertia. Therefore, even if the Servo Driver parameters are properly adjusted at a normal temperature, the Servomotor may not operate optimally at low temperatures. Check operation at low temperatures to see whether operation is optimal in those conditions, too.

### 3-2-3 Encoder Specifications

Item	Specification	
Encoder method	Optical encoder (incremental encoder)	
Number of output pulses	Phase A, B: 256 waves/revolution Phase Z: 1 pulse/revolution	
Power supply voltage	5 VDC $\pm 5\%$	
Power supply current	70 mA max.	
Output signals	+A, -A, +B, -B, Z, U, V, and W	
Output interface	+A, -A, +B, and -B	Sine wave voltage output
	Z, U, V, and W	Transistor output

# 3-3 Decelerator Specifications

## 3-3-1 Standard Models and Specifications

The following Decelerators are available for use with SMARTSTEP Junior Servomotors. Select a Decelerator to match the Servomotor capacity.

- Backlash: 3 arcminutes max.
- Backlash: 45 arcminutes max.

There are four reduction ratios: 1/5, 1/9, 1/15, and 1/25.

### ■ Backlash: 3 Arcminutes Max.

Model			Rated speed	Rated torque	Ratio	Maximum momentary speed	Maximum momentary torque	Decelerator inertia	Allowable radial load	Allowable thrust load
			r/min	N·m	%	r/min	N·m	kg·m <sup>2</sup>	N	N
100 W	1/5	R7G-VRSFPB05B100	600	1.19	75	900	3.60	$4.08 \times 10^{-6}$	392	196
	1/9	R7G-VRSFPB09B100	333	2.29	80	500	6.91	$3.43 \times 10^{-6}$	441	220
	1/15	R7G-VRSFPB15B100	200	3.82	80	300	11.5	$3.62 \times 10^{-6}$	588	294
	1/25	R7G-VRSFPB25C100	120	6.36	80	180	19.2	$3.92 \times 10^{-6}$	1323	661
200 W	1/5	R7G-VRSFPB05B200	600	2.71	85	900	8.12	$1.53 \times 10^{-5}$	392	196
	1/9	R7G-VRSFPB09C400	333	3.78	66	500	11.3	$2.68 \times 10^{-5}$	931	465
	1/15	R7G-VRSFPB15C400	200	6.31	66	300	18.9	$2.71 \times 10^{-5}$	1176	588
	1/25	R7G-VRSFPB25C200	120	11.1	70	180	33.4	$2.67 \times 10^{-5}$	1323	661
400 W	1/5	R7G-VRSFPB05C400	600	5.40	85	900	16.2	$3.22 \times 10^{-5}$	784	392
	1/9	R7G-VRSFPB09C400	333	9.49	83	500	28.5	$2.68 \times 10^{-5}$	931	465
	1/15	R7G-VRSFPB15C400	200	15.8	83	300	47.6	$2.71 \times 10^{-5}$	1176	588
	1/25	R7G-VRSFPB25D400	120	26.4	83	180	79.3	$2.79 \times 10^{-5}$	1617	808
750 W	1/5	R7G-VRSFPB05C750	600	10.8	90	900	32.0	$7.17 \times 10^{-5}$	784	392
	1/9	R7G-VRSFPB09D750	333	18.3	85	500	54.3	$6.50 \times 10^{-5}$	1176	588
	1/15	R7G-VRSFPB15D750	200	30.5	85	300	90.5	$7.09 \times 10^{-5}$	1372	686
	1/25	R7G-VRSFPB25E750	120	50.8	85	180	151	$7.05 \times 10^{-5}$	2058	1029

- Note 1. The Decelerator inertia is the Servomotor shaft conversion value.  
 2. The enclosure rating for Servomotors with Decelerators is IP44.  
 3. The allowable radial load is the value at the center of the shaft.

### ■ Backlash: 45 Arcminutes Max.

Model			Rated speed	Rated torque	Ratio	Maximum momentary speed	Maximum momentary torque	Decelerator inertia	Allowable radial load	Allowable thrust load
			r/min	N·m	%	r/min	N·m	kg·m <sup>2</sup>	N	N
100 W	1/5	R7G-RGSF05B100	600	1.19	75	900	3.60	$4.08 \times 10^{-6}$	392	196
	1/9	R7G-RGSF09B100	333	2.29	80	500	6.91	$3.43 \times 10^{-6}$	441	220
	1/15	R7G-RGSF15B100	200	3.82	80	300	11.5	$3.62 \times 10^{-6}$	588	294
200 W	1/5	R7G-RGSF05B200	600	2.71	85	900	8.12	$1.53 \times 10^{-5}$	392	196
	1/9	R7G-RGSF09C400	333	3.78	66	500	11.3	$2.68 \times 10^{-5}$	931	465
	1/15	R7G-RGSF15C400	200	6.31	66	300	18.9	$2.71 \times 10^{-5}$	1176	588
400 W	1/5	R7G-RGSF05C400	600	5.40	85	900	16.2	$3.22 \times 10^{-5}$	784	392
	1/9	R7G-RGSF09C400	333	9.49	83	500	28.5	$2.68 \times 10^{-5}$	931	465
	1/15	R7G-RGSF15C400	200	15.8	83	300	47.6	$2.71 \times 10^{-5}$	1176	588

- Note 1. The Decelerator inertia is the Servomotor shaft conversion value.  
 2. The enclosure rating for Servomotors with Decelerators is IP44.  
 3. The allowable radial load is the value at the center of the shaft.

### 3-4 Cable and Connector Specifications

#### 3-4-1 Control Cable Specifications

## 3-4 Cable and Connector Specifications

### 3-4-1 Control Cable Specifications

#### ■ General-purpose Control Cables (R7A-CPZ□□□S)

A General-purpose Control Cable connects to the Servo Driver's Control I/O Connector (CN1). There is no connector on the controller end. Wire a connector to match the controller if you are connecting to a Position Control Unit and a compatible cable is not available or connecting to a controller manufactured by another company.

#### ● Cable Models

Model	Length (L)	Outer diameter of cable	Weight
R7A-CPZ001S	1 m	5.6 dia.	Approx. 0.1 kg
R7A-CPZ002S	2 m		Approx. 0.2 kg

#### ● Connection Configuration and Dimensions

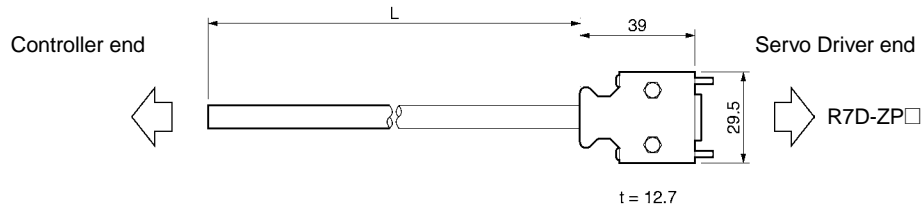

#### ● Wiring

No.	Wire color/Mark color	Signal
1	Orange/Red (-)	+CW/PULS
2	Orange/Black (-)	-CW/PULS
3	Gray/Red (-)	+CCW/SIGN
4	Gray/Black (-)	-CCW/SIGN
5	White/Red (-)	+24VIN
6	Yellow/Black (-)	RUN
7	White/Black (-)	OGND
8	Pink/Red (-)	+ECRST
9	Pink/Black (-)	-ECRST
10	Orange/Red (--)	Z
11	Orange/Black (--)	ZCOM
12	Gray/Red (--)	/ALM
13	Gray/Black (--)	BKIR
14	Yellow/Red (-)	INP

Connector plug: 10114-3000VE (Sumitomo 3M)

Connector case: 10314-52A0-008 (Sumitomo 3M)

Cable: AWG24 × 7P UL20276

Wires with the same wire color and the same number of marks are a twisted pair.

#### ● Connector Pin Arrangement

2	1	9	8
4	3	11	10
6	5	13	12
	7		14

## 3-4-2 Servomotor Power Cable Specifications

The Servomotor Cable supplies power between the Servo Driver and Servomotor. Servomotor Power Cables are available in two forms: Servomotor Power Cables with an attached CNB Connector and Servomotor Power Cables without a connector (Cable Only). Select the Cable to match the Servomotor being used.

Note: When connecting to moving parts, use robot cable and make a custom cable.

### ■ Power Cables with CNB Connector for Servomotors without Brakes

#### ● Cable Models

Model	Length (L)	Outer diameter of cable	Weight
R7A-CAZ003S	3 m	7.4 dia.	Approx. 0.4 kg
R7A-CAZ005S	5 m		Approx. 0.8 kg
R7A-CAZ010S	10 m		Approx. 1.2 kg

Note: The maximum distance between the Servo Driver and Servomotor is 20 meters.

#### ● Connection Configuration and Dimensions

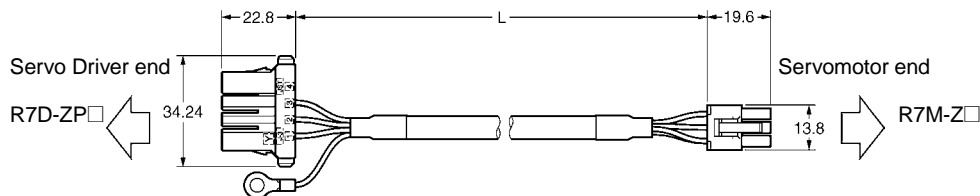

#### ● Wiring

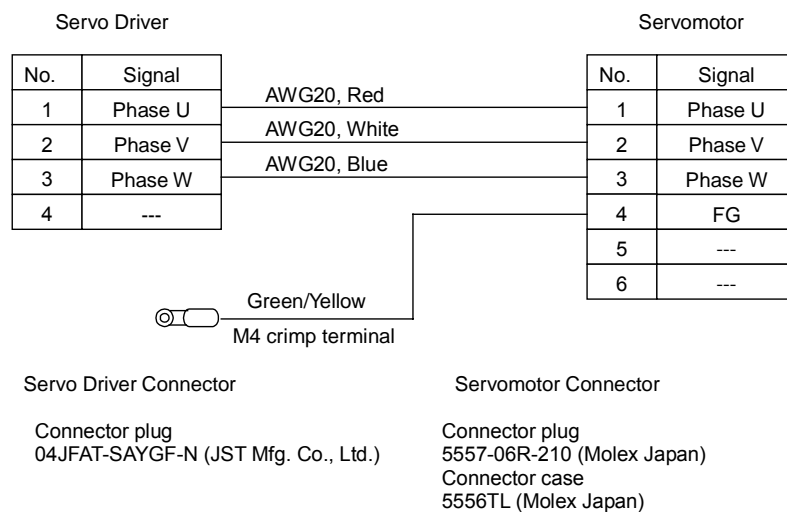

### 3-4 Cable and Connector Specifications

#### 3-4-2 Servomotor Power Cable Specifications

#### ■ Power Cables without Connector (Loose Wires) for Servomotors without Brakes

##### ● Cable Models

Model	Length (L)	Outer diameter of cable	Weight
R7A-CAZ001	1 m	7.4 dia.	Approx. 0.1 kg

- Note 1. The maximum distance between the Servo Driver and Servomotor is 20 meters.  
 2. Cables are sold in 1-m increments. It is cut to the specified length.

#### ■ Power Cables with CNB Connector for Servomotors with Brakes

##### ● Cable Models

Model	Length (L)	Outer diameter of cable	Weight
R7A-CAZ003B	3 m	7.4 dia.	Approx. 0.4 kg
R7A-CAZ005B	5 m		Approx. 0.8 kg
R7A-CAZ010B	10 m		Approx. 1.2 kg

Note: The maximum distance between the Servo Driver and Servomotor is 20 meters.

##### ● Connection Configuration and Dimensions

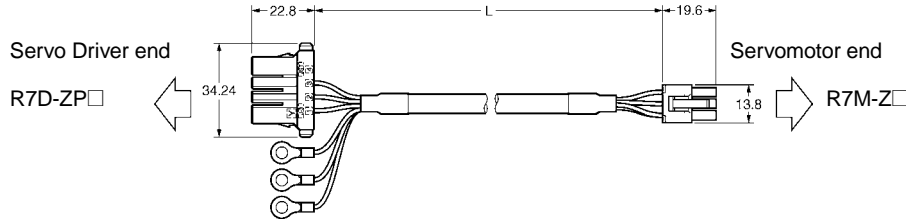

##### ● Wiring

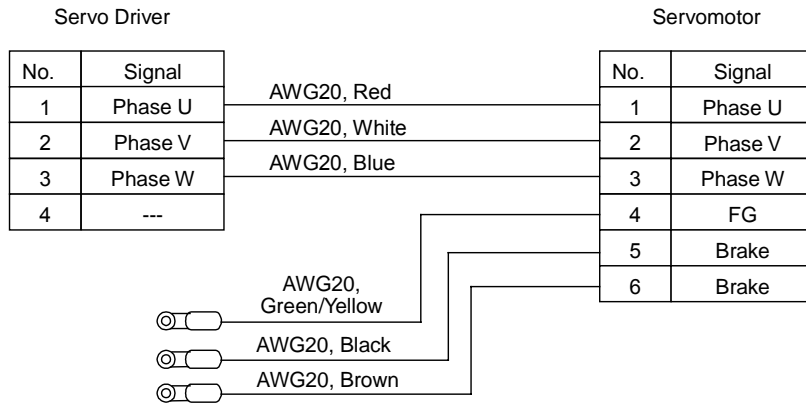

Servo Driver Connector:

Connector plug  
 04JFAT-SAYGF-N (JST Mfg. Co., Ltd.)

Servomotor Connector:

Connector plug  
 5557-06R-210 (Molex Japan)  
 Connector case  
 5556TL (Molex Japan)

## 3-4 Cable and Connector Specifications

### 3-4-3 Encoder Cable Specifications

#### ■ Power Cables without Connectors (Loose Wires) for Servomotors with Brakes

- Cable Models

Model	Length (L)	Outer diameter of cable	Weight
R7A-CAZ01B	1 m	7.4 dia.	Approx. 0.1 kg

- Note
1. The maximum distance between the Servo Driver and Servomotor is 20 meters.
  2. Cables are sold in 1-m increments. It is cut to the specified length.

### 3-4-3 Encoder Cable Specifications

The Encoder Cable connects the encoder between the Servo Driver and Servomotor. Encoder Cables are available in two forms: Encoder Cables with an attached CN2 Connector and plain cable only.

Note: When connecting to moving parts, use robot cable to make a custom cable.

#### ■ Encoder Cable (CN2 Connector Attached)

- Cable Models

Model	Length (L)	Outer diameter of cable	Weight
R7A-CRZ003C	3 m	7.1 dia.	Approx. 0.4 kg
R7A-CRZ005C	5 m		Approx. 0.8 kg
R7A-CRZ010C	10 m		Approx. 1.2 kg

Note: The maximum distance between the Servo Driver and Servomotor is 20 meters.

- Connection Configuration and Dimensions

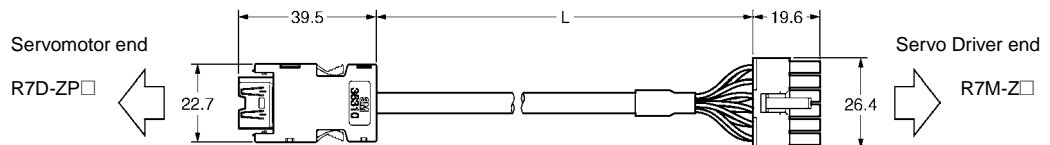



### 3-4 Cable and Connector Specifications

#### 3-4-4 Connector Specifications

- Wiring

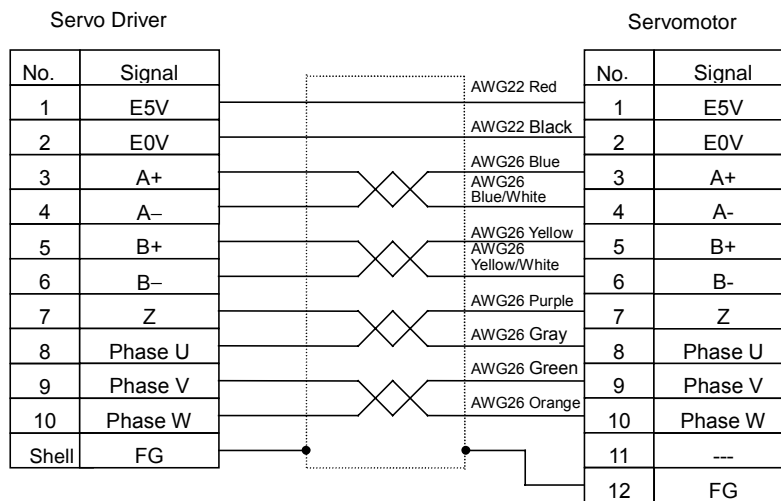

Servo Driver Connector:

Plug  
54593-1019  
Connector case  
54599-1005 (JST Mfg. Co., Ltd.)

Servomotor Connector:

Connector plug  
5557-12R-210  
Connector case  
5556T2L  
(JST Mfg. Co., Ltd.)

#### ■ Encoder Cable (Loose Wires Only)

- Cable Models

Model	Length (L)	Outer diameter of cable	Weight
R7A-CRZ001	1 m	7.1 dia.	Approx. 0.1 kg

- Note 1. The maximum distance between the Servo Driver and Servomotor is 20 meters.  
2. Cable are sold in 1-m increments. It is cut to the specified length.

### 3-4-4 Connector Specifications

#### ■ Main Circuit Connector (R7A-CNZ01P)

The Main Circuit Connector connects to the Servo Driver's Main Circuit Connector (CNA).

- Dimensions

Main Circuit Connector  
04JFAT-SBXGF-N  
(JST Mfg. Co., Ltd.)

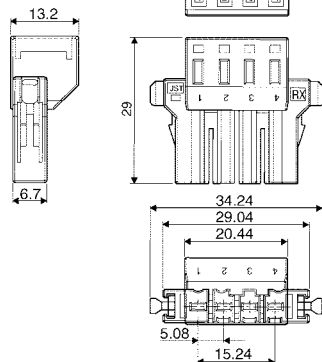

Wiring Lever  
J-FAT-OT  
(JST Mfg. Co., Ltd.)

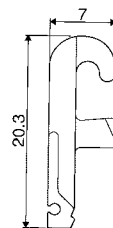

■ Servomotor Connector (R7A-CNZ01A)

The Servomotor Connector connects to the Servo Driver's Servomotor Connector (CNB).

● Dimensions

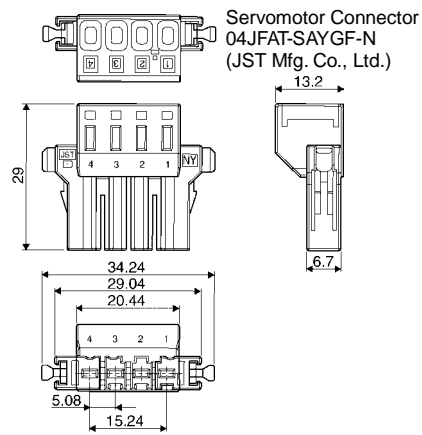

## 3-5 Regeneration Resistance Unit

### 3-5-1 Regeneration Resistance Unit (R88A-RG08UA) Specifications

# 3-5 Regeneration Resistance Unit

## 3-5-1 Regeneration Resistance Unit (R88A-RG08UA) Specifications

### ■ General Specifications

Item	Specifications
Ambient operating temperature	0 to 55°C
Ambient operating humidity	35% to 85% (with no condensation)
Ambient storage temperature	-10 to 75°C
Ambient storage humidity	35% to 85% (with no condensation)
Storage and operating atmosphere	No corrosive gasses
Vibration resistance	4.9 m/s <sup>2</sup> max.
Impact resistance	Acceleration 19.6 m/s <sup>2</sup> max.

### ■ Characteristics

Item	Specifications
Regeneration operating voltage	380 VDC
Regeneration current	8 A (DC)
Average internal regeneration power	12 W (internal resistance: 50 Ω, 60 W)
Externally connected regeneration resistance	47 Ω ±5%
Error detection functions	Regeneration resistance disconnection, Regeneration transistor failure, and overvoltage
Alarm output	Single-pole NC contact (open when protection function is operating), can handle 200 VAC.
Dimensions	55 × 160 × 130 mm (W × H × D)

### ■ LED Indicator Specifications

Item	Specifications
POWER	Lit when power is being supplied to the P and N terminals.
REGEN	Lit during regeneration operation.
ALARM-REGEN	Lit when the regeneration resistance is disconnected or the regeneration transistor failed.
ALARM-OV	Lit when there is an overvoltage.

- Note
1. If an error is detected, an alarm is output from the Regeneration Resistance Unit. Set up a sequence so that the power to the Servo Driver (L1 and L2) is turned OFF when an alarm occurs.
  2. When an error is detected and the Servo Driver's power is turned OFF, the Regeneration Resistance Unit will not reset normally unless the Servo Driver's power is OFF for 2 to 3 seconds. (The Regeneration Resistance Unit will reset to its normal status after the Servo Driver's internal capacitors discharge completely and the voltage drops across terminals P and N.)
  3. The Regeneration Resistance Unit does not comply with the EC Directives.

### 3-5 Regeneration Resistance Unit 3-5-1 Regeneration Resistance Unit (R88A-RG08UA) Specifications

#### ■ Dimensions

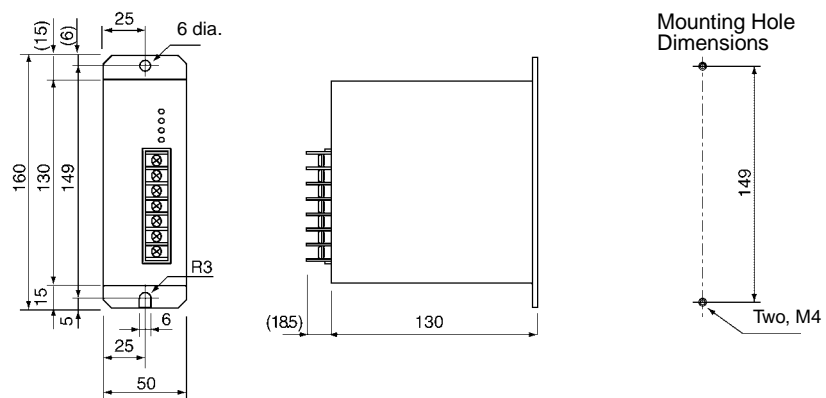

### 3-6 AC Reactors

#### 3-6-1 AC Reactor Specifications

## 3-6 AC Reactors

An AC Reactor can be connected to the Servo Driver to suppress harmonic currents. Select a model to match the Servo Driver being used.

### 3-6-1 AC Reactor Specifications

#### ■ Specifications

Servo Driver model	AC Reactor			
	Model	Rated current (A)	Inductance (mH)	Weight (kg)
R7D-ZP01H	R88A-PX5052	1.0	45.0	Approx. 0.4
R7D-ZP02H	R88A-PX5053	2.0	20.0	Approx. 0.6
R7D-ZP04H	R88A-PX5054	3.0	5.0	Approx. 0.4
R7D-ZP08H	R88A-PX5056	5.0	2.0	Approx. 0.4

#### ■ Dimensions

Units: mm

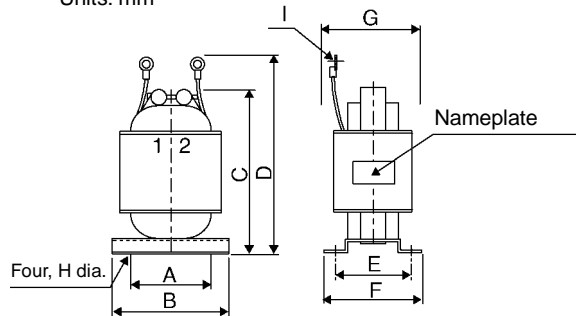

Model	A	B	C	D	E	F	G	H dia.	I dia.
R88A-PX5052	35	52	80	95	30	40	45	4	4.3
R88A-PX5053	35	52	90	105	35	45	50	4	4.3
R88A-PX5054	35	52	80	95	30	40	45	4	4.5
R88A-PX5056	35	52	80	95	30	40	45	4	4.3

**Section 4**

**System Design**

## 4-1 Installation Conditions

### 4-1-1 Servo Drivers

# 4-1 Installation Conditions

## 4-1-1 Servo Drivers

### ■ Space around Drivers

Install Servo Drivers according to the dimensions shown in the following illustration to ensure proper heat dispersion and convection inside the panel. Also install a fan for circulation if the Servo Drivers are installed side by side to prevent uneven temperatures from developing inside the panel.

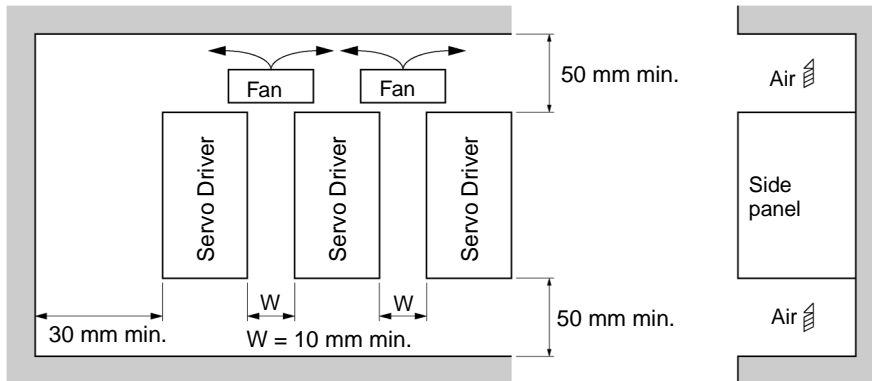

### ■ Mounting Direction

Mount the Servo Drivers in a direction (perpendicular) such that the lettering for the model number, and so on, can be seen.

### ■ Operating Environment

The environment in which Servo Drivers are operated must meet the following conditions. Servo Drivers may malfunction if operated under any other conditions.

- Ambient operating temperature: 0 to 55°C (Take into account temperature rises in the individual Servo Drivers themselves.)
- Ambient operating humidity: 20% to 90% max. (with no condensation)
- Atmosphere: No corrosive gases.

### ■ Ambient Temperature

- Servo Drivers should be operated in environments in which there is minimal temperature rise to maintain a high level of reliability.
- Temperature rise in any Unit installed in a closed space, such as a control box, will cause the Servo Driver's ambient temperature to rise. Use a fan or air conditioner to prevent the Servo Driver's ambient temperature from exceeding 55°C.
- Servo Driver surface temperatures may rise to as much as 30°C above the ambient temperature. Use heat-resistant materials for wiring, and keep separate any devices or wiring that are sensitive to heat.
- The service life of a Servo Driver is largely determined by the temperature around the internal electrolytic capacitors. The service life of an electrolytic capacitor is affected by a drop in electrolytic volume and an increase in internal resistance, which can result in overvoltage alarms, malfunctioning due to noise, and damage to individual elements.
- If a Servo Driver is always operated at the maximum ambient temperature of 40°C and at 80% of the rated torque, then a service life of approximately 50,000 hours can be expected (excluding axial-flow fan). A drop of 10°C in the ambient temperature will double the expected service life.

#### ■ Keeping Foreign Objects Out of Units

- Place a cover over the Units or take other preventative measures to prevent foreign objects, such as drill filings, from getting into the Units during installation. Be sure to remove the cover after installation is complete. If the cover is left on during operation, heat buildup may damage the Units.
- Take measures during installation and operation to prevent foreign objects such as metal particles, oil, machining oil, dust, or water from getting inside of Servo Drivers.

## 4-1-2 Servomotors

#### ■ Operating Environment

The environment in which the Servomotor is operated must meet the following conditions. Operating the Servomotor outside of the following ranges may result in malfunction of the Servomotor.

- Ambient operating temperature: 0 to +40°C
- Ambient operating humidity: 20% to 80% (with no condensation)
- Atmosphere: No corrosive gases.

#### ■ Impact and Load

- The Servomotor is resistant to impacts of up to  $98 \text{ m/s}^2$ . Do not subject it to heavy impacts or loads during transport, installation, or removal.
- When transporting it, hold onto the Servomotor itself, and do not hold onto the encoder, cable, or connector areas. Holding onto weaker areas such as these can damage the Servomotor.
- Always use a pulley remover to remove pulleys, couplings, or other objects from the shaft.
- Secure cables so that there is no impact or load placed on the cable connector areas.

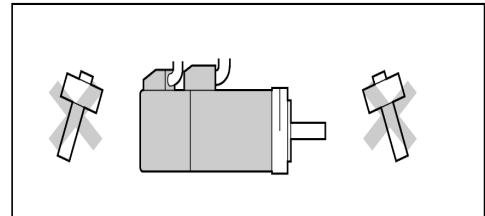

#### ■ Connecting to Mechanical Systems

- The axial loads for Servomotors are specified in 3-2-2 *Characteristics*. If an axial load greater than that specified is applied to a Servomotor, it will reduce the service life of the motor bearings and may damage the motor shaft.
- When connecting to a load, use couplings that can sufficiently absorb mechanical eccentricity and variation.
- For spur gears, an extremely large radial load may be applied depending on the gear precision. Use spur gears with a high degree of accuracy (for example, JIS class 2: normal line pitch error of  $6 \mu\text{m}$  max. for a pitch circle diameter of 50 mm).
- If the gear precision is not adequate, allow backlash to ensure that no radial load is placed on the motor shaft.

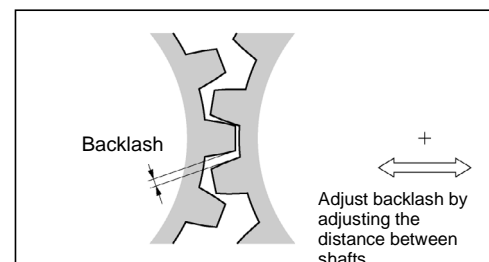
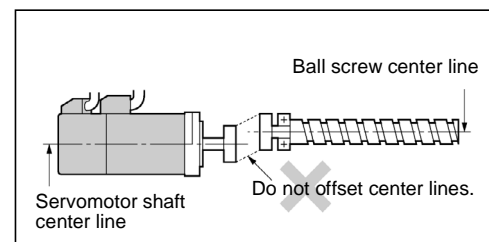



## 4-1 Installation Conditions

### 4-1-2 Servomotors

- Bevel gears will cause a load to be applied in the thrust direction depending on the structural precision, the gear precision, and temperature changes. Provide appropriate backlash or take other measures to ensure that no thrust load is applied which exceeds specifications.
- Do not put rubber packing on the flange surface.
- When connecting to a V-belt or timing belt, consult the maker for belt selection and tension.
- A radial load twice the belt tension will be placed on the motor shaft. Do not allow a radial load exceeding specifications to be placed on the motor shaft due to belt tension. If an excessive radial load is applied, the motor shaft and bearings may be damaged.
- Set up a movable pulley between the motor axis and the load axis so that the belt tension can be adjusted.

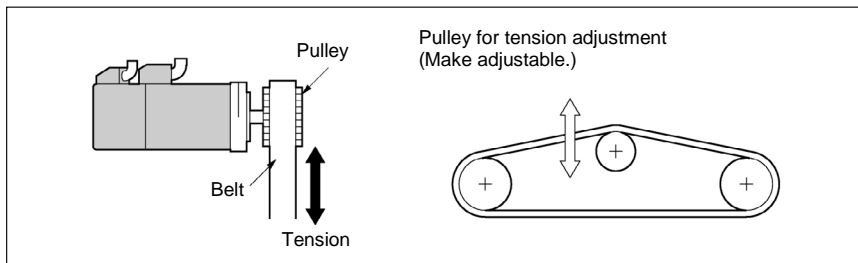
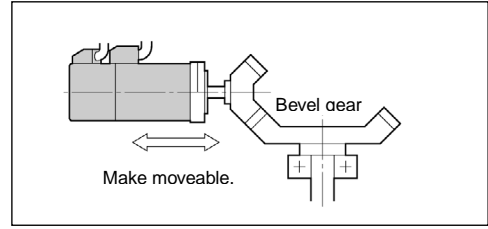

### ■ Water and Drip Resistance

The enclosure ratings for the Servomotors are as follows:  
IP55 (except for through-shaft parts and cable exit holes)

### ■ Other Precautions

Take measures to prevent the shaft from rusting. The shafts are coated with anti-rust oil when shipped, but anti-rust oil or grease should also be applied when connecting the shaft to a load.



## WARNING



### WARNING

Do not apply commercial power directly to the Servomotor. Applying commercial power directly will burn out the motor coils.



### WARNING

Do not attempt to disassemble, repair, or modify any Units. Any attempts to do so may result in electric shock or other injury.

## 4-1-3 Decelerators

### ■ Installing Decelerators

- Use only the specified combinations of Servomotors and Decelerators. The service life of the motor bearings may be shortened you use a combination that is not specified, another company's reductions gear, or another company's Servomotor.
- The dimensions of the Servomotor mounting flange on the Decelerators differ for each Servomotor. Do not install Decelerators on a Servomotor other than the one specified.
- Use the following procedure when installing a Decelerator on the Servomotor.
- When installing the Servomotor, avoid the Servomotor shaft's key groove when installing the set bolt.

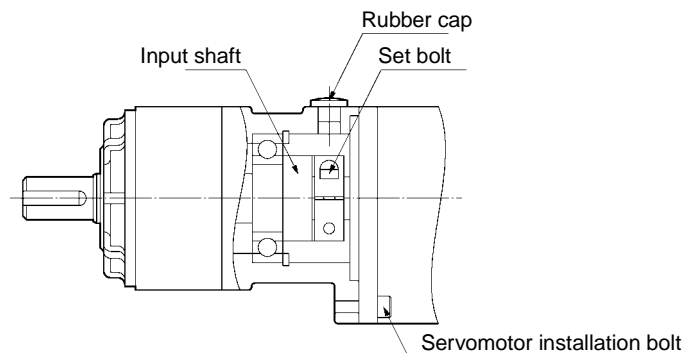

- (1) Remove the rubber cap and check that the set bolt is loose.
- (2) Insert the Servomotor shaft into the input shaft.
- (3) Tighten the Servomotor installation bolt to the torque specified in the following table.

Servomotor installation bolt	Tightening torque (N·m)
M4	2.9
M5	5.8
M6	9.8

- (4) Tighten the set bolt to the torque specified in the following table.

Set bolt	Tightening torque (N·m)
M3	1.0
M4	2.9

- (5) After tightening the set bolt, replace the rubber cap.

### ■ Using Another Company's Decelerator (Reference Information)

If the system configuration requires another company's decelerator to be used in combination with a SMARTSTEP Junior Servomotor, select the decelerator so that the load on the motor shaft (i.e., both the radial and thrust loads) is with the allowable values. (Refer to 3-2-2 *Characteristics* for details on the allowable loads for motors.) Also, select the decelerator so that the allowable input speed and allowable input torque of the decelerator is not exceeded.

# 4-2 Wiring

## 4-2-1 Connecting Cables

This section shows the types of connecting cables used in a SMARTSTEP Junior system. A wide selection of cables are available for OMRON SYSMAC Position Control Units, making it easy to wire a servo system.

### System Configuration

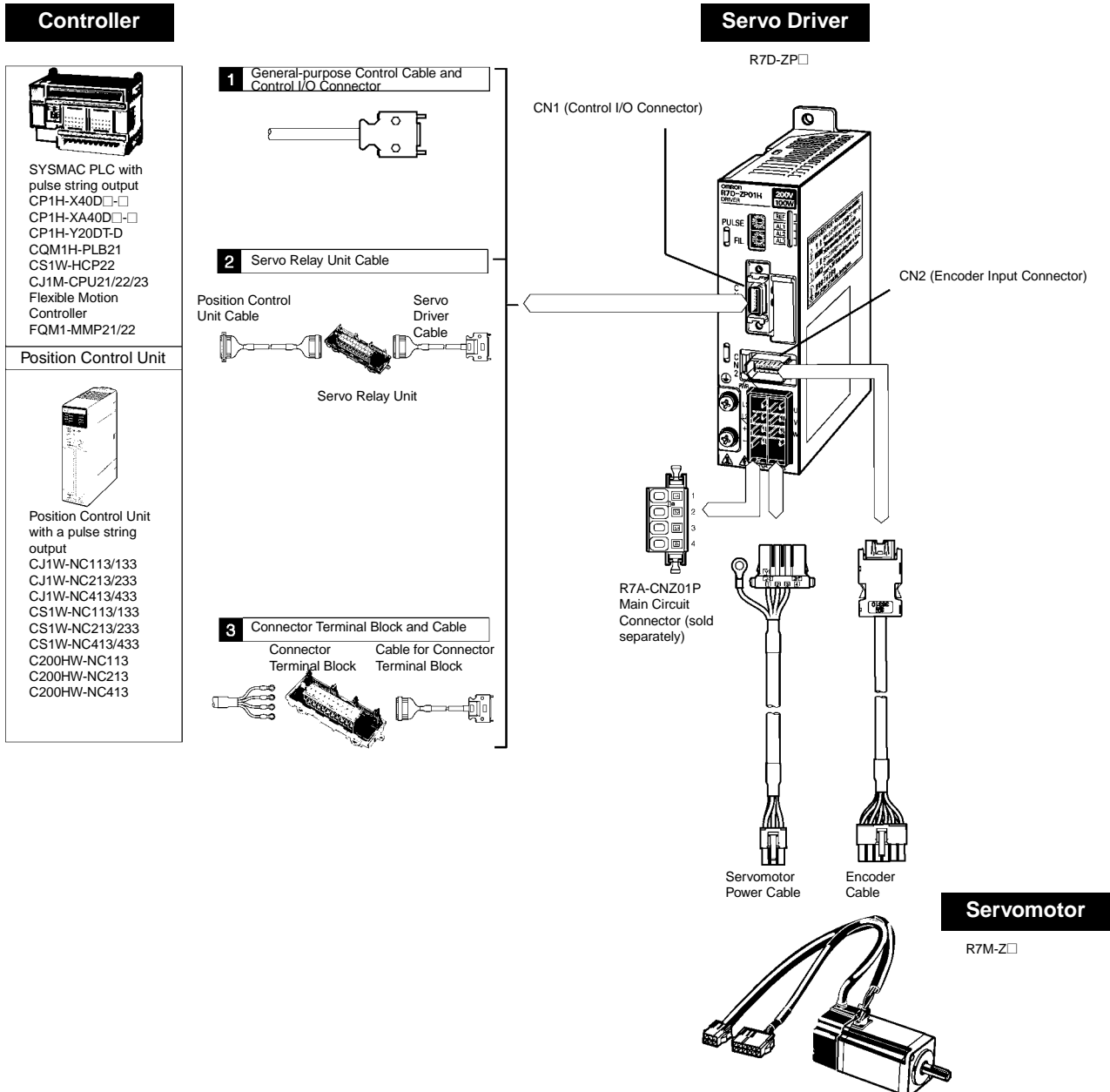

## 4-2-2 Selecting Connecting Cables

### ■ General-purpose Control Cables

If you are connecting to a controller that does not have a standard cable available, use General-purpose Control Cable to assemble a cable to connect to the Servo Driver's Control I/O Connector (CN1).

Name	Model number	Comments
General-purpose Control Cable	R7A-CPZ□□□S	This cable has a connector attached to connect to the Control I/O Connector (CN1). The □□□ digits in the model number indicate the cable length (either 1 m or 2 m). Example model number: R7A-CPZ001S (1 m)

### ■ Servomotor Power Cables (CNB)

There are two kinds of Servomotor Power Cables, one for Servomotors with a brake and another for Servomotors without a brake. Select the Cable to match the Servomotor being used.

Specification	Model number	Comments
For a Servomotor without a brake	R7A-CAZ□□□S	The □□□ digits in the model number indicate the cable length (3 m, 5 m, or 10 m). Example model number: R7A-CAZ003S (3 m cable for a Servomotor without a brake)
For a Servomotor with a brake	R7A-CAZ□□□B	

### ■ Encoder Cables (CN2)

Name	Model number	Comments
Encoder Cable	R7A-CRZ□□□C	The □□□ digits in the model number indicate the cable length (3 m, 5 m, or 10 m). Example model number: R7A-CRZ003C (3 m)

## 4-2 Wiring

### 4-2-3 Peripheral Device Connection Examples

#### 4-2-3 Peripheral Device Connection Examples

##### ■ R7D-ZP01H/-ZP02H/-ZP04H/-ZP08H

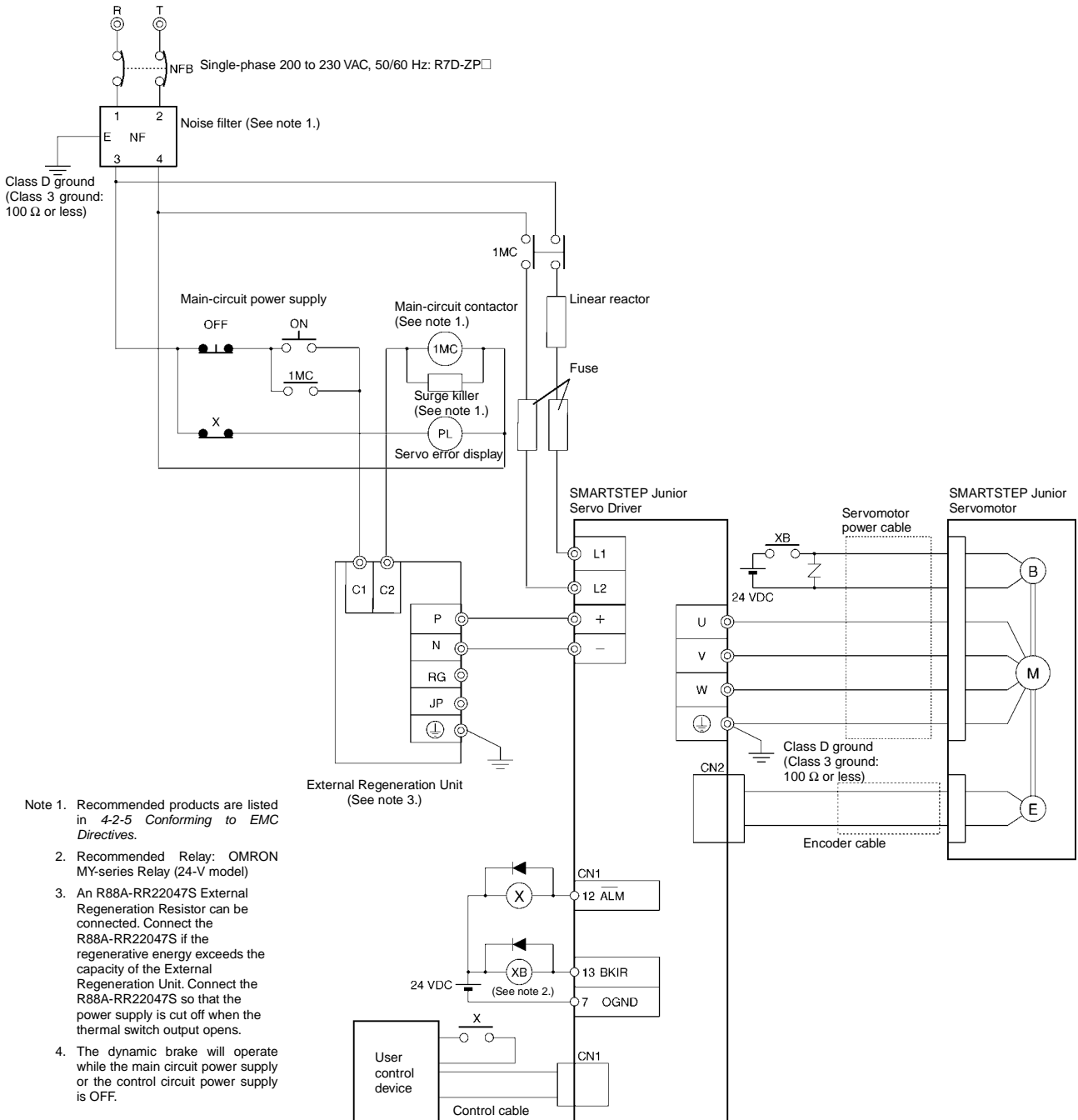

## 4-2-4 Wiring the Main Circuit and Servomotor Connections

When wiring a Terminal Block, use proper wire sizes, grounding systems, and anti-noise measures.

### ■ Terminal Block Names and Functions

Signal	Function	Condition	
L1	Main circuits power supply input	Single-phase 200/230 V AC (170 to 253 V AC) 50/60 Hz	
L2			
+	External regeneration resistance connection terminals	If regenerative energy is high, connect an External Regeneration Unit.	
-			
U	Servomotor connection terminals	Red	These are the terminals for outputs to the Servomotor. Be sure to wire these terminals correctly.
V		White	
W		Blue	
⊕		Green/Yellow	
⊕	Frame ground	This is the ground terminal. Ground to a minimum of 100 Ω (class D, class 3).	

### ■ Terminal Block Wire Sizes

Model (R7D-)			ZP01H	ZP02H	ZP04H	ZP08H
Item	Unit					
Power supply capacity	kVA		0.4	0.75	1.2	2.2
Main circuit power supply input (L1, L2)	Rated current	A (rms)	1.8	3.5	5.5	10
	Wire size	mm <sup>2</sup>	1.25		2.0	
External Regeneration Unit connection terminals (+, -)	Wire size	mm <sup>2</sup>	1.25 (Wiring length: 0.5 m max.)			
Servomotor connection terminal (U, V, W, ⊕) (See note.)	Rated current	A (rms)	0.84	1.1	2.0	3.7
	Maximum momentary current	A (rms)	2.5	3.3	6.0	11.1
	Wire size	mm <sup>2</sup>	1.25 (Wiring length: 20 m max.)			
Frame ground	Wire size	mm <sup>2</sup>	2.0 min.			
	Screw size	---	M4			
	Torque	N•m	1.2 to 1.4			
No-fuse breaker or fuse capacity	A (rms)		4	8	16	

Note: Connect an OMRON Servomotor Cable to the Servomotor connection terminals.

### ■ Wire Size and Allowable Current (Reference)

The following table shows the allowable current when there are three power supply wires. Use a current below these specified values.

## 4-2 Wiring

### 4-2-4 Wiring the Main Circuit and Servomotor Connections

- 600-V Heat-resistant Vinyl Wire (HIV) (Reference Values)

AWG size	Cross-sectional area (mm <sup>2</sup> )	Configuration (wires/mm <sup>2</sup> )	Conductive resistance (Ω/km)	Allowable current (A) for ambient temperature		
				30°C	40°C	50°C
20	0.5	19/0.18	39.5	6.6	5.6	4.5
---	0.75	30/0.18	26.0	8.8	7.0	5.5
18	0.9	37/0.18	24.4	9.0	7.7	6.0
16	1.25	50/0.18	15.6	12.0	11.0	8.5
14	2.0	7/0.6	9.53	23	20	16
12	3.5	7/0.8	5.41	33	29	24

### ■ Terminal Block Wiring Procedure

Spring-type connectors are used for SMARTSTEP Junior Servo Drivers. The procedure for wiring these is described below.

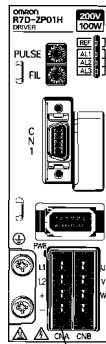

CNA Connector

1. Remove the Terminal Block from the Servo Driver.

The Terminal Block must be removed from the Servo Driver before being wired.

The Servo Driver will be damaged if the wiring is done with the Terminal Block in place.

2. Strip the covering off the ends of the wires.

Prepare wires of the right sizes, according to the tables provided under *Terminal Block Wire Sizes* above, and strip off 9 to 10 mm of the covering from the end of each wire.

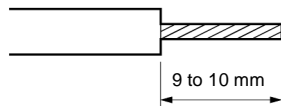

3. Open the wire insertion slots in the Terminal Block

There are two ways to open the wire insertion slots, as follows:

- Pry the slot open using the lever that comes with the Servo Driver (as in Fig. A).
- Insert a flat-blade screwdriver (end width: 2.5 to 3.0 mm) into the opening for Servo Driver installation, and press down firmly to open the slot (as in Fig. B).



4. Insert the wire into the slot.

With the slot held open, insert the end of the wire. Then let the slot close by releasing the pressure from the lever or the screwdriver.

5. Mount the Terminal Block to the Servo Driver.

After all of the terminals have been wired, return the Terminal Block to its original position on the Servo Driver.

## 4-2-5 Conforming to EMC Directives

Conformance to EMC Directives (EN55011 class A group 1 (EMI) and EN61000-6-2 EMS)) can be ensured by wiring under the conditions described below. These conditions are for conformance of SMARTSTEP Junior products to EMC Directives.

EMC-related performance of these products, however, will vary depending on the configuration, wiring, and other conditions of the equipment in which the products are installed. The customer must, therefore, perform final checks to confirm that devices and the overall installation conform to EMC Directives.

The following conditions must be met to conform to EMC Directives.

- The Servo Driver must be installed in a metal case (control panel). (The Servomotor does not, however, have to be covered with a metal plate.)
- Noise filters and surge absorbers must be installed on all power supply lines.
- Shielded cables must be used for all I/O signal lines and encoder lines. (Use tin-plated, soft copper wires for the shield weaving.)
- All cables leaving the control panel must be wired in metal ducts or conduits with blades. (The 30-cm power cable, encoder cable, and connector do not have to be inserted in metal ducts or conduits.)
- Clamp filters must be installed on cables with braided shields, and the shield must be directly grounded to a ground plate.



## 4-2 Wiring

### 4-2-5 Conforming to EMC Directives

#### ■ Wiring Method

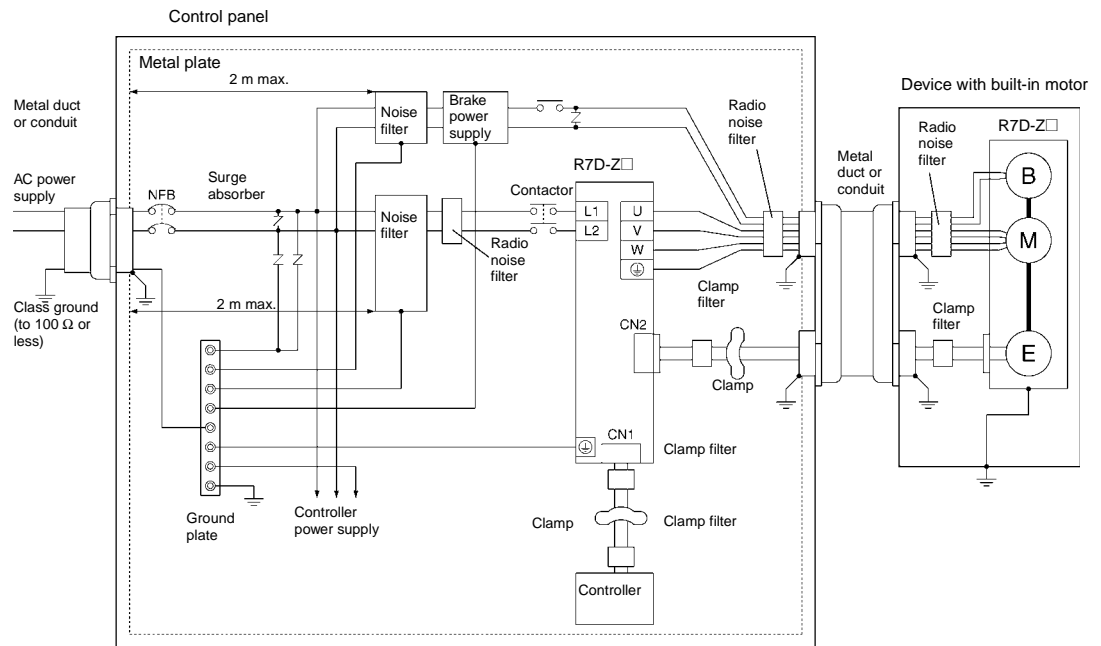

- Note 1. Make 1.5 turns for the ferrite core's cable winding.  
 2. Peel the insulation off the cable at the clamp, and directly connect the shield to the metal plate.

- Ground the motor's frame to the machine ground when the motor is on a movable shaft.
- Use a grounding plate for the frame ground for each Unit, as shown in the above diagrams, and ground to a single point.
- Use ground lines with a minimum thickness of  $3.5 \text{ mm}^2$ , and arrange the wiring so that the ground lines are as short as possible.
- No-fuse breakers, surge absorbers, and noise filters (NF) should be positioned near the input terminal block (ground plate), and I/O lines should be isolated and wired using the shortest distance possible.
- If no-fuse breakers are installed at the top and the power supply line is wired from the lower duct, use metal tubes for wiring and make sure that there is adequate distance between the input lines and the internal wiring. If input and output lines are wired together, noise resistance will decrease.
- Wire the noise filter as shown at the left in the following illustration. The noise filter should be installed at the entrance to the control box whenever possible.

#### Correct: Separate input and output

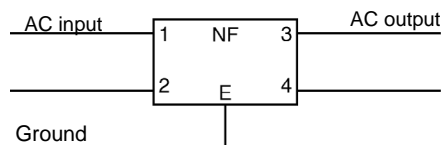

#### Wrong: Noise not filtered effectively

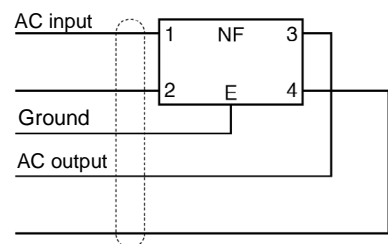

- Use twisted-pair cables for the power supply cables whenever possible, or bind the cables.

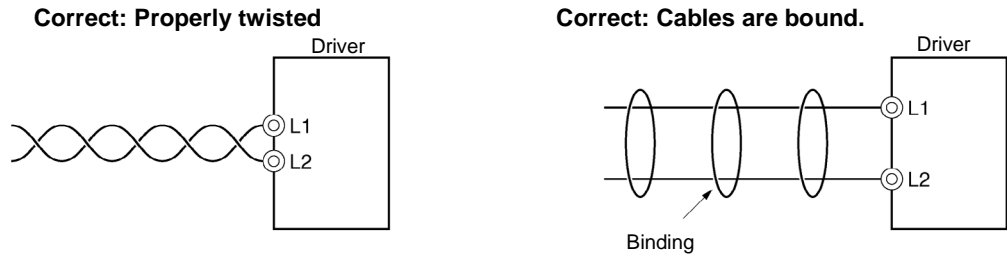

- Separate power supply cables and signal cables when wiring.

## ■ Control Panel Construction

Openings in the control panel, such as holes for cables, operating panel mounting holes, and gaps around the door, may allow electromagnetic waves into the panel. To prevent this from occurring, observe the recommendations described below when designing or selecting a control panel.

- Case Structure
  - Use a metal control panel with welded joints at the top, bottom, and sides so that the surfaces will be electrically conductive.
  - During assembly, strip the paint off of joint areas (or mask them during painting), to make them electrically conductive.
  - If gaps appear in the control box case when screws are tightened, make adjustments to prevent this from occurring.
  - Do not leave any conductive part unconnected.
  - Ground all Units within the case to the case itself.
- Door Structure
  - Use a door that is made of metal.
  - Use a water-draining structure where the door and case fit together, and leave no gaps. (Refer to the diagrams below.)
  - Use a conductive gasket between the door and the case, as shown in the diagrams below. (Refer to the diagrams below.) Strip the paint off of the sections of the door and case that will be in contact with the conductive gasket (or mask them during painting), so that they will be electrically conductive.
  - Gaps may open between case panels when screws are tightened. Be sure that no gaps appear when tightening down screws.

## 4-2 Wiring

### 4-2-5 Conforming to EMC Directives

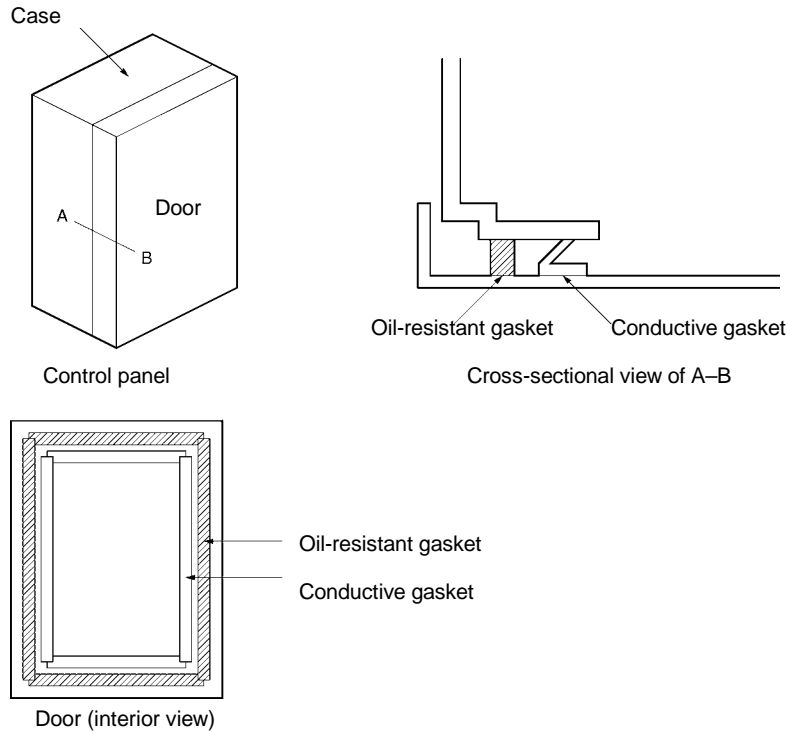

### ■ Selecting Connection Components

This section explains the criteria for selecting the connection components required to improve noise resistance. Review each component's characteristics, such as its capacity, performance, and applicable conditions when selecting the components. For more details, contact the manufacturers directly.

#### ● Fuses

Always install a fuse at each Servo Driver to prevent fire or burn damage. We recommend the following fuses, based on the rated current, current at the maximum momentary torque, and inrush current when the power is turned ON.

Servo Driver			Fuse (Littelfuse, Inc.)			Fuse block (Littelfuse, Inc.)	
Model	Capacity (W)	Momentary rating A (rms)	Model	Rating A	Inrush $A_{0-P}$	Model	Specifications
R7D-ZP01H	100	4	KLK015	15	30	L60030M-2SQ	Max. AC voltage: 600 V Max. rated current: 30 A Screw/Q.C. Terminals
R7D-ZP02H	200	4					
R7D-ZP04H	400	8					
R7D-ZP08H	750	16	KLK030	30	60		

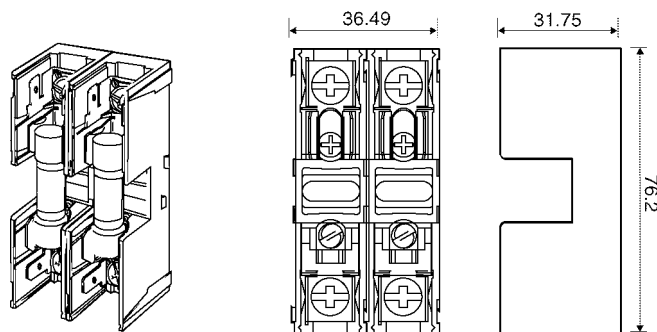

- No-fuse Breakers (NFB)

- When selecting a no-fuse breaker, consider the maximum input current and the inrush current.

Maximum Input Current:

- The Servo Driver's maximum momentary output is approximately three times the rated output, and can be output for up to three seconds. Therefore, select no-fuse breakers with an operating time of at least five seconds at 300% of the rated maximum output. General-purpose and low-speed no-fuse breakers are generally suitable.
- The table in 4-2-4 *Wiring the Main Circuit and Servomotor Connections* shows the rated power supply input current for each Servomotor. Select a no-fuse-breaker with a rated current greater than the total effective load current (when multiple Servomotors are used).
- Add the current consumption of other controllers, and any other components, when selecting the NFB.

Inrush Current:

- The following table lists the Servo Drivers' inrush currents.
- With low-speed no-fuse breakers, an inrush current 10 times the rated current flows for 0.02 second.
- When there is a simultaneous inrush for multiple Servo Drivers, select a no-fuse-breaker with a 20-ms allowable current greater than the total inrush current for those Servo Drivers, shown in the following table.

Servo Driver model	Inrush current ( $A_{0-p}$ )
	Main circuit power supply
R7D-ZP01H/-ZP02H/-ZP04H	30
R7D-ZP08H	60

- Surge Absorbers

- Use surge absorbers to absorb surges from power supply input lines due to lightning, abnormal voltages, etc.
- When selecting surge absorbers, take into account the varistor voltage, the amount of surge immunity, and the amount of energy resistance.
- For 200-V AC systems, use surge absorbers with a varistor voltage of 470 V.
- The surge absorbers shown in the following table are recommended.

Maker	Model	Max. limit voltage	Surge immunity	Type	Remarks
Okaya Electric Industries Co., Ltd.	R-A-V-781BYZ-2	783 V	2,500 A	Block	Between power supply lines
	R-A-V-781BWZ-4	783 V	2,500 A		Between power supply line grounds

- Note
1. Refer to the manufacturers' documentation for operating details.
  2. The surge immunity is for a standard impulse current of 8/20  $\mu$ s. If pulses are wide, either decrease the current or change to a larger-capacity surge absorber.

## 4-2 Wiring

### 4-2-5 Conforming to EMC Directives

- Noise Filters for the Power Supply Input
  - Use the following noise filters for the Servo Driver's power supply.

Servo Driver model	Noise filter				
	Model (See note.)	Rated current	Rated voltage	Leakage current (50 Hz)	Maker
R7D-ZP01H/ZP02H	FN2070-6/07	6 A	250 V	0.4 mA/phase	Schaffner
R7D-ZP04H	FN2070-10/07	10 A	250 V	0.4 mA/ phase	
R7D-ZP08H	FN2070-16/07	16 A	250 V	0.4 mA/ phase	

Note: The last two digits of the noise filter model number indicate the type of terminal connection. The /07 models have lead wires, the /06 models have fast-on connections that can be soldered, and the /08 models have screw terminals. Select the appropriate version for your application. Contact the manufacturer ([www.schaffner.com](http://www.schaffner.com)) for details.

### Dimensions

The following diagram shows the dimensions of a noise filter with lead wires. Contact the manufacturer for dimensions of the noise filters with other connections.

Single-phase Input (Models FN2070-6 /07 and FN2070-10 /07)

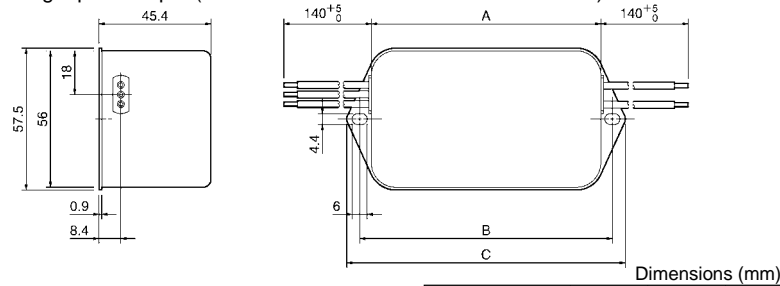

Single-phase Input (Model FN2070-16 /07)

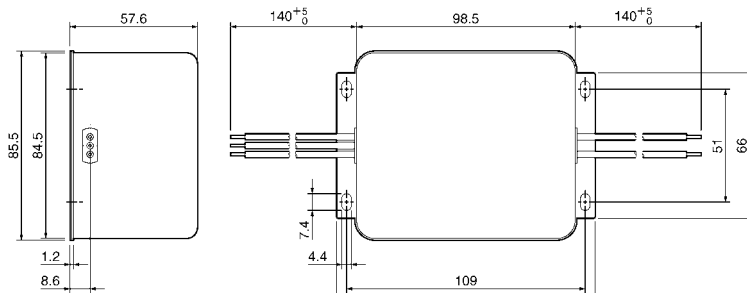

- Noise Filter for the Brake Power Supply
  - Use the following noise filter for the brake power supply.

Model	Rated current	Rated voltage	Leakage current	Maker
SUP-P5H-EPR	5 A	250 V	0.6 mA (at 250 Vrms, 60 Hz)	Okaya Electric Industries Co., Ltd.

Dimensions

- Noise Filter for the Brake Power Supply (SUP-P5H-EPR)

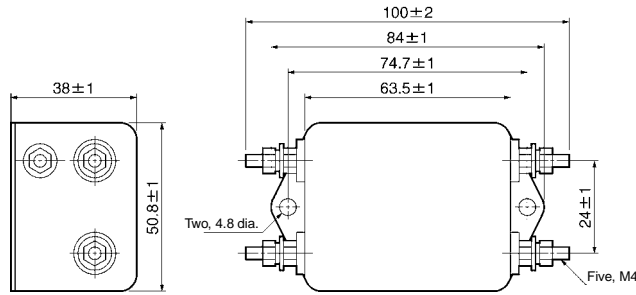

- Surge Suppressors

- Install surge suppressors for loads that have induction coils, such as relays, solenoids, brakes, clutches, etc.
- The following table shows types of surge killers and recommended products.

Type	Features	Recommended products
Diode	Diodes are used for relatively small loads when the reset time is not an issue, such as relays. The reset time is increased because the surge voltage is the lowest when power is cut off. Used for 24/48-V DC systems.	Use a fast-recovery diode with a short reverse recovery time.  Example: Fuji Electric Co., ERA22-06
Thyristor or varistor	Thyristors and varistors are used for loads when induction coils are large, as in electromagnetic brakes, solenoids, etc., and when reset time is an issue. The surge voltage when power is cut off is approximately 1.5 times the varistor voltage.	Select the varistor voltage as follows: 24 VDC system: 39 V 100 VDC system: 200 V 100 VAC system: 270 V 200 VAC system: 470 V
Capacitor + resistor	The capacitor + resistor combination is used to absorb vibration in the surge when power is cut off. The reset time can be shortened by selecting the appropriate capacitance and resistance.	Okaya Electric Industries Co., Ltd. XEB12002 0.2 μF – 120 Ω XEB12003 0.3 μF – 120 Ω

Note: Thyristors and varistors are made by the following companies. Refer to manufacturers' documentation for details on these components.

Thyristors: Ishizuka Electronics Co.

Varistors: Ishizuka Electronics Co., Matsushita Electric Industrial Co.

- Contactors

- Select contactors based on the circuit's inrush current and the maximum momentary current.
- The Servo Driver inrush current is covered in the preceding explanation of no-fuse breaker selection, and the maximum momentary current is approximately twice the rated current.
- The following table shows the recommended contactors.

Maker	Model number	Rated current	Coil voltage
OMRON	J7L-09-22200	11 A	200 VAC
	J7L-12-22200	13 A	200 VAC
	J7L-18-22200	18 A	200 VAC
	J7L-32-22200	26 A	200 VAC

## 4-2 Wiring

### 4-2-5 Conforming to EMC Directives

- Leakage Breakers

- Use leakage breakers designed for motors.
- Since switching takes place inside the Servo Drivers, harmonic current leaks from the armature of the motor. With leakage breakers designed for motors, harmonic current is not detected, preventing the breaker from operating due to leakage current.
- When selecting leakage breakers, remember to add the leakage current in devices besides the Servomotor that use the switching power supply, such as noise filters and inverters.
- For details on leakage breakers, refer to the manufacturer's catalog.
- The following table shows the Servomotor leakage current for each Servo Driver model.

Servo Driver model	Driver Leakage current (resistor/capacitor measurement) in the commercial power supply frequency range
R7D-ZP01H/-ZP02H/-ZP04H	3 mA max.
R7D-ZP08H	5 mA max.

- Note 1. The leakage current shown above is for Servomotor power cables less than 5 meters long.  
(The leakage current depends on the power cable length and the insulation.)
2. The leakage current shown above is for normal temperature and humidity. (The leakage current depends on the temperature and humidity.)

The following table shows the recommended leakage breakers. (Conform to UL/CSA and CE standards.)

Maker	Model number	Rated current	Sensitive current
Fuji Electric Corp.	EG33CM/30-30MA-CE	30 A	30 mA
	EG33CM/30-100MA-CE	30 A	100 mA

#### Leakage Breaker Connection Example

Leakage Breaker Connection Example

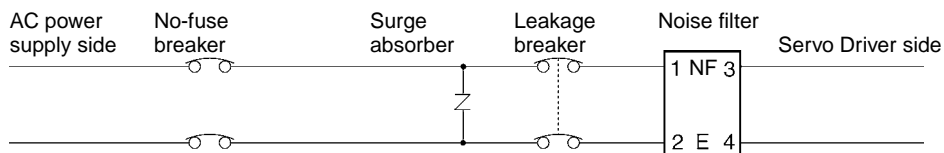

- Radio Noise Filters

Use a radio noise filter to reduce the Servo Driver's PWM noise. The following table shows some available radio noise filters.

Maker	Model number
FDK Corporation	RN603620M
	RN80UD
Hitachi Metals	FT-3KMF6045GB
	FT-3KMS10085GB
	FT-1KMF6045GB

■ **Improving Encoder Cable Noise Resistance**

Take the following steps during wiring and installation to improve the encoder's noise resistance.

- Always use the specified Encoder Cables.
- If cables are joined midway, be sure to connect them with connectors and do not remove more than 50 mm of the cable insulation. In addition, always use shielded cable.
- Do not coil cables. If cables are long and are coiled, mutual induction and inductance will increase and will cause malfunctions. Always use cables fully extended.
- When installing noise filters for Encoder Cables, use clamp filters. The following table shows the recommended ferrite-core clamp filter models.

Maker	Product name	Model number	Specifications
NEC TOKIN	Clamp-type EMI Core	ESD-SR-250	For cable diameter up to 13 mm
TDK	Clamp Filters for Cable	ZCAT2032-0930	For cable diameter up to 9 mm
		ZCAT3035-1330	For cable diameter up to 13 mm
		ZCAT2035-0930A	For cable diameter up to 9 mm

- Do not place the Encoder Cable in the same duct as Control Cables for brakes, solenoids, clutches, and valves.

■ **Improving Control I/O Signal Noise Resistance**

Positioning can be affected and I/O signal errors can occur if control I/O is influenced by noise. Follow the methods outlined below for the power supply and wiring.

- Use completely separate power supplies for the control power supply (especially 24 V DC) and the external operation power supply. In particular, do not connect the two power supply ground wires. Install a noise filter on the primary side of the control power supply.
- If Servomotors with brakes are being used, do not use the same 24-VDC power supply for both the brakes and the control I/O. Additionally, do not connect the ground wires. Connecting the ground wires may cause I/O signal errors.
- Keep the power supply for pulse commands and deviation counter reset input lines separated from the control power supply as far as possible. In particular, do not connect the two power supply ground lines.
- We recommend using line drivers for the pulse command and deviation counter reset outputs.
- Always use twisted-pair shielded cable for the pulse command and deviation counter reset signal lines, and connect both ends of the shield to frame grounds.
- If the control power supply wiring is long, noise resistance can be improved by adding 1- $\mu$ F laminated ceramic capacitors between the control power supply and ground at the Servo Driver input section or the controller output section.
- For open-collector specifications, keep the length of wires to within two meters.



## 4-2 Wiring

### 4-2-5 Conforming to EMC Directives

#### ■ Selecting Other Parts for Noise Resistance

This section explains the criteria for selecting other connection components required to improve noise resistance. Review each component's characteristics, such as its capacity, performance, and applicable conditions when selecting the components. For more details, contact the manufacturers directly.

##### ● Noise Filters for the Power Supply Input

- Use a noise filter to attenuate external noise and reduce noise emitted from the Servo Driver.
- Select a noise filter with a rated current that is at least two times greater than the effective load current (the rated current of the main circuit power supply input shown in the table in *4-2-4 Wiring the Main Circuit and Servomotor Connections*).

Maker	Model number	Rated current	Applicable standards
NEC TOKIN	GT-2050	5 A	UL, CSA, VDE, and TUV
	GT-2100	10 A	
	GT-2150	15 A	
	GT-2200	20 A	
Soshin Electric Company	HF2005A-UP	5 A	UL and TUV
	HF2010A-UP	10 A	
	HF2015A-UP	15 A	
	HF2020A-UP	20 A	
	HF2030A-UP	30 A	
TDK	ZRCS2006-00S	6 A	UL, CSA, and NEMKO
	ZRCS2010-00S	10 A	
	ZRCS2020-00S	20 A	
	ZRCS2030-00S	30 A	

- Note 1. To attenuate noise at low frequencies below 200 kHz, use an isolation transformer and a noise filter.
2. To attenuate noise at high frequencies over 30 MHz, use a ferrite core and a high-frequency noise filter with a through-type capacitor.
3. If multiple Servo Drivers are being connected to a single noise filter, select a noise filter with a rated current at least two times the total rated current of all the Servo Drivers.

##### ● Noise Filters for Servomotor Output

- Use noise filters without built-in capacitors on the Servomotor output lines.
- Select a noise filter with a rated current at least two times the Servo Driver's continuous output current.
- The following table shows the noise filters that are recommended for Servomotor output.

Maker	Model number	Rated current	Applicable standards	Remarks
NEC TOKIN	LF-310KA	10 A	UL	For inverter output
	LF-320KA	20 A		
Soshin Electric Company	CC3005C-AZ	5 A	---	For inverter output
	CC3010C-AZ	10 A		
	CC3015C-AZ	15 A		

- Note 1. Servomotor output lines cannot use the same noise filters used for power supplies.
2. Typical noise filters are used with power supply frequencies of 50/60 Hz. If these noise filters are connected to outputs of 11.7 kHz (the Servo Driver's PWM frequency), a very large (about 100 times larger) leakage current will flow through the noise filter's condenser and the Servo Driver could be damaged.

## 4-3 Regenerative Energy Absorption

The Servo Drivers have internal regenerative energy absorption circuitry, which absorbs the regenerative energy produced during Servomotor deceleration and prevents the DC voltage from increasing. An overvoltage error is generated, however, if the amount of regenerative energy from the Servomotor is too large. If this occurs, measures must be taken to reduce the regenerative energy produced by changing operating patterns, or to increase the regenerative energy absorption capacity by connecting external regeneration resistance.

### 4-3-1 Calculating the Regenerative Energy

#### ■ Horizontal Axis

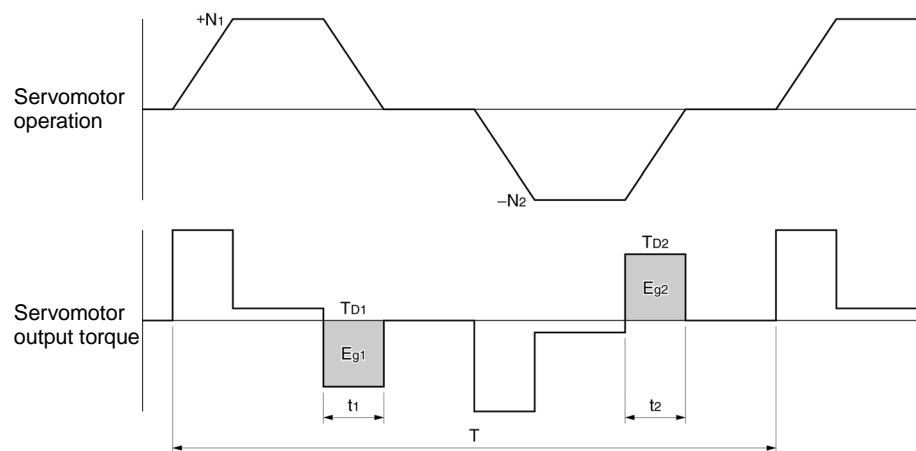

Note: In the output torque graph, acceleration in the positive direction is shown as positive, and acceleration in the negative direction is shown as negative.

- The regenerative energy values for each region can be derived from the following equations.

$$E_{g1} = \frac{1}{2} * \frac{2\pi}{60} * N_1 * T_{D1} * t_1 \text{ [J]} = 0.0524 * N_1 * T_{D1} * t_1 \text{ [J]}$$

$$E_{g2} = \frac{1}{2} * \frac{2\pi}{60} * N_2 * T_{D2} * t_2 \text{ [J]} = 0.0524 * N_2 * T_{D2} * t_2 \text{ [J]}$$

$N_1, N_2$ : Rotation speed at beginning of deceleration [r/min]  
 $T_{D1}, T_{D2}$ : Deceleration torque [N·m]  
 $t_1, t_2$ : Deceleration time [s]

Note: There is some loss due to winding resistance, so the actual regenerative energy will be approximately 90% of the values derived from these equations.

- The average regeneration power ( $Pr$ ) is the power consumed by regeneration resistance in one cycle of operation.

$$Pr = (E_{g1} + E_{g2}) / T \text{ [W]}$$

T: Operation cycle [s]

## 4-3 Regenerative Energy Absorption

### 4-3-1 Calculating the Regenerative Energy

- Since there is an internal capacitor to absorb regenerative energy, the value for  $E_{g1}$  and  $E_{g2}$  (unit: J) must be lower than the Servo Driver's regenerative energy absorption capacity. (The capacity varies depending on the model. For details, refer to 4-3-2 Servo Driver Regenerative Energy Absorption Capacity.)

If an external Regeneration Resistance Unit is connected, be sure that the average regeneration power ( $P_r$ ) does not exceed the external Regeneration Resistance Unit's regenerative energy absorption capacity (12 W).

#### ■ Vertical Axis

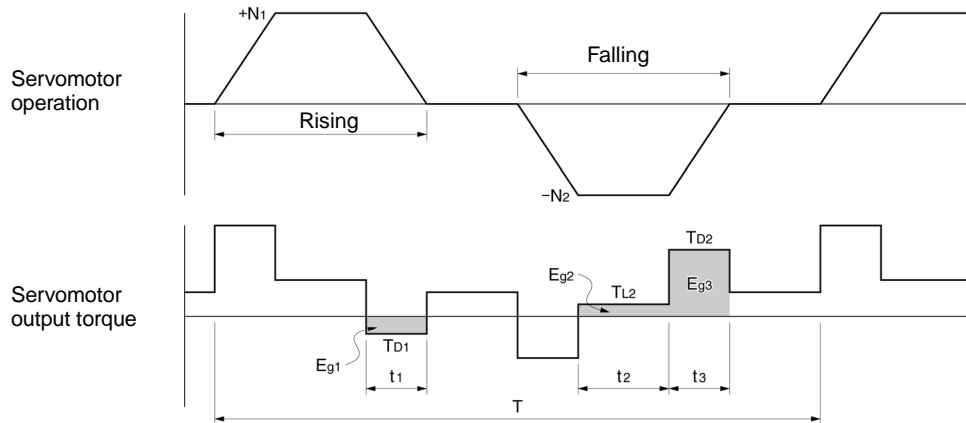

Note: In the output torque graph, acceleration in the positive direction (rising) is shown as positive, and acceleration in the negative direction (falling) is shown as negative.

- The regenerative energy values in each region can be derived from the following equations.

$$E_{g1} = \frac{1}{2} * \frac{2\pi}{60} * N_1 * T_{D1} * t_1 \quad [\text{J}] = 0.0524 * N_1 * T_{D1} * t_1 \quad [\text{J}]$$

$$E_{g2} = \frac{2\pi}{60} * N_2 * T_{L2} * t_2 \quad [\text{J}] = 0.105 * N_2 * T_{L2} * t_2 \quad [\text{J}]$$

$$E_{g3} = \frac{1}{2} * \frac{2\pi}{60} * N_2 * T_{D2} * t_3 \quad [\text{J}] = 0.0524 * N_2 * T_{D2} * t_3 \quad [\text{J}]$$

$N_1, N_2$ : Rotation speed at beginning of deceleration [r/min]

$T_{D1}, T_{D2}$ : Deceleration torque [N·m]

$T_{L2}$ : Torque when falling [N·m]

$t_1, t_3$ : Deceleration time [s]

$t_2$ : Constant-velocity travel time when falling [s]

Note: There is some loss due to winding resistance, so the actual regenerative energy will be approximately 90% of the values derived from these equations.

- The average regeneration power ( $P_r$ ) is the power consumed by regeneration resistance in one cycle of operation.

$$P_r = (E_{g1} + E_{g2} + E_{g3}) / T \quad [\text{W}]$$

T: Operation cycle [s]

## 4-3 Regenerative Energy Absorption

### 4-3-2 Servo Driver Regenerative Energy Absorption Capacity

- Since there is an internal capacitor to absorb regenerative energy, the value for  $E_{g1}$  and  $E_{g2} + E_{g3}$  (unit: J) must be lower than the Servo Driver's regenerative energy absorption capacity. (The capacity varies depending on the model. For details, refer to *4-3-2 Servo Driver Regenerative Energy Absorption Capacity*.)  
If an external Regeneration Resistance Unit is connected, be sure that the average regeneration power ( $P_r$ ) does not exceed the external Regeneration Resistance Unit's regenerative energy absorption capacity (12 W).

### 4-3-2 Servo Driver Regenerative Energy Absorption Capacity

#### ■ Amount of Internal Regeneration Resistance in Servo Drivers

The SMARTSTEP Junior Servo Drivers absorb regenerative energy internally with built-in capacitors. If the regenerative energy is too large to be processed internally, an overvoltage error is generated and operation cannot continue. The following table shows the regenerative energy (and amount of regeneration) that each Servo Driver can absorb. If these values are exceeded, take the following measures.

- Connect an External Regeneration Resistance Unit (to increase the regeneration processing capacity).
- Reduce the operating rotation speed. (The amount of regeneration is proportional to the square of the rotation speed.)
- Lengthen the deceleration time (to decrease the regenerative energy produced per time unit).
- Lengthen the operation cycle, i.e., the cycle time (to decrease the average regenerative power).

Servo Driver	Regenerative energy (J) that can be absorbed by the internal capacitor
R7D-ZP01H	13
R7D-ZP02H	19
R7D-ZP04H	28
R7D-ZP08H	59

### 4-3-3 Absorbing Regenerative Energy with an External Resistor

If the regenerative energy exceeds the absorption capacity of the R88A-RG08UA External Regenerative Resistance Unit, connect an External Regeneration Resistor. To connect an External Regeneration Resistor, remove the shorting bar between the RG-JP terminals and connect the resistor to the P-RG terminals. Double-check the terminal names when connecting the resistor, because the External Regeneration Resistance Unit can be damaged if the resistor is connected to the wrong terminals. (The External Regeneration Resistance Unit does not conform to EC Directives.)

Note: The External Regeneration Resistor can reach a temperature of approximately 120°C, so install it at a distance from heat-sensitive devices and wiring. In addition, install a heat-radiating heat sink to cool the resistor if necessary.

#### ■ External Regeneration Resistor

- External Regeneration Resistor Models

Model	Resistance	Nominal capacity	Regeneration absorption at 120°C	Heat radiation	Thermal switch output specifications
R88A-RR22047S	47 Ω ±5%	220 W	70 W	t1.0 × □350 (SPCC)	Operating temperature: 170°C ±5% NC contact Rated output: 3A

## 4-3 Regenerative Energy Absorption

### 4-3-3 Absorbing Regenerative Energy with an External Resistor

- Combining External Regeneration Resistors

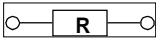
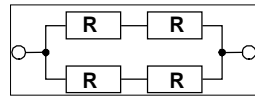
Resistor configurations	Regeneration absorption capacity	
	70 W	280 W
		

Note: Select a combination that has an absorption capacity greater than the average regeneration power ( $P_r$ ).

- Dimensions

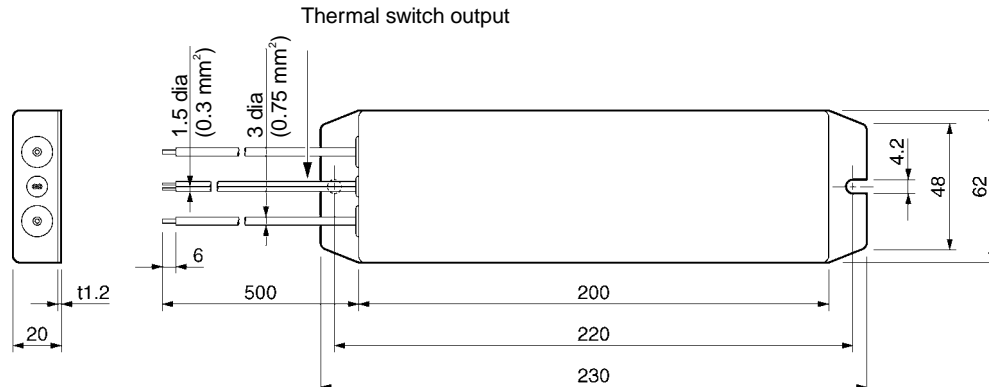

- Wiring the External Regeneration Resistor

When installing an External Regeneration Resistor, remove the shorting bar between the RG-JP terminals and connect the resistor to the P-RG terminals.

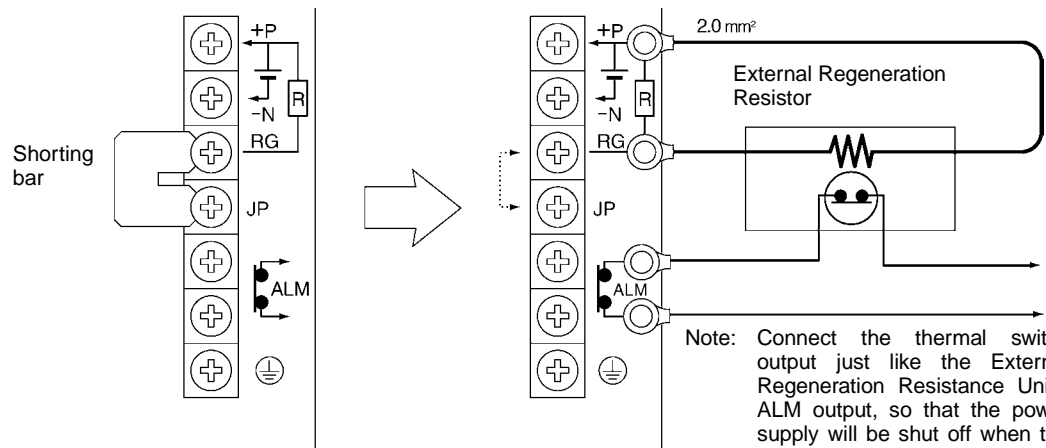

**Section 5**

**Operation**

## 5-1 Operational Procedure

### 5-1-1 Operational Procedure

# 5-1 Operational Procedure

## 5-1-1 Operational Procedure

After mounting, wiring, and connecting a power supply, check the operation of the Servomotor and Servo Driver.

Item	Description	Reference
Mounting and installation	Install the Servomotor and Servo Driver according to the installation conditions. (Do not connect the Servomotor to the mechanical system before checking the no-load operation.)	Section 4-1



Wiring and connections	Connect to power supply and peripheral devices. Note: Specified installation and wiring requirements must be satisfied, particularly for models conforming to the EC Directives.	Section 4-2
------------------------	---	-------------



Switch settings	Make sure that the power supply is turned OFF, and set the Servo Driver's front panel switches.	Section 5-2
-----------------	---	-------------



Preparing for operation	After checking the necessary items, turn ON the Unit's power supply. Check to see whether there are any internal errors in the Servo Driver.	Section 5-3
-------------------------	--	-------------



Trial operation	Firstly, check the Servomotor's no-load operation. Next, turn the power OFF then ON again, and connect the Servomotor to the mechanical system. Turn ON the power, and check to see whether protective functions such as emergency stop and operational limits are working reliably. Check operation at both low speed and high speed, with either no workpiece or a dummy workpiece.	Section 5-4
-----------------	---	-------------



Adjustments	Manually adjust the gain as required.	Section 5-2
-------------	---------------------------------------	-------------



Operation	Operation can now begin. If any trouble should occur, refer to <i>Section 6 Troubleshooting</i> .	Section 6
-----------	---	-----------

# 5-2 Switch Settings

With SMARTSTEP Junior Servo Drivers, the settings required for operation can be made simply by setting the front panel switches. Set the switches appropriately according to the system configuration.



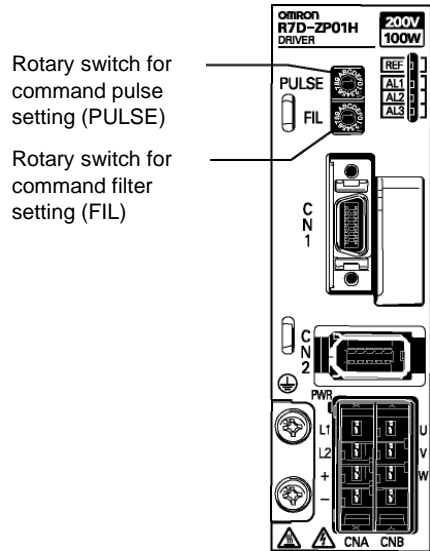



## 5-2-1 Switch Names

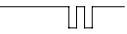
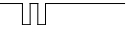

## 5-2-2 Switch Functions

### ■ Rotary Switch for Command Pulse Setting (PULSE)

Always turn OFF the power supply before setting the rotary switch. (The switch is factory-set to 0.)

Setting	Command pulse resolution	Command pulse connection method	Command pulse type
0	1000	Open collector or line driver	CW + CCW, positive logic CW  CCW 
1	2500		
2	5000		
3	10000	Line driver	
4	1000	Open collector or line driver	CW + CCW, negative logic CW  CCW 
5	2500		
6	5000		
7	10000	Line driver	
8	1000	Open collector or line driver	Sign + pulse string, positive logic PULS  SIGN 
9	2500		
A	5000		
B	10000	Line driver	
C	1000	Open collector or line driver	Sign + pulse string, negative logic PULS  SIGN 
D	2500		
E	5000		
F	10000	Line driver	



## 5-2 Switch Settings

### 5-2-2 Switch Functions

#### ■ Rotary Switch for Command Filter Setting (FIL)

This switch does not need to be set if the machine is not subject to vibration. (The switch is factory-set to 0.)

Filter setting (See note 1.)	Acceleration/deceleration time for STEP command (See note 3.)	Approx. time from end of command to end of positioning (settling time) (See note 2.)	Description
0	45 ms	100 to 200 ms	 <p>Smaller filter time constant (short positioning time)</p> <p>Larger filter time constant (longer positioning time with little vibration)</p>
1	50 ms	110 to 220 ms	
2	60 ms	130 to 260 ms	
3	65 ms	150 to 300 ms	
4	70 ms	170 to 340 ms	
5	80 ms	200 to 400 ms	
6	85 ms	250 to 500 ms	
7	170 ms	500 to 1000 ms	
8 to F	Do not set this switch to 8 to F.		

- Note 1. Increase the value of the filter setting if there is vibration when starting or stopping.
2. The settling time depends on the commanded acceleration/deceleration, the rigidity of the machine motor drive, the encoder resolution, and other factors.
3. Use the acceleration/deceleration times as a guideline for determining the Servomotor capacity that can be driven when using STEP commands without command acceleration/deceleration.

## **5-3 Preparing for Operation**

This section explains the procedure following installation, wiring, and switch setting of the Servomotor and Servo Driver, to prepare the mechanical system for trial operation.

It explains what you need to check both before and after turning ON the power.

### **5-3-1 Turning ON the Power and Checking Indicators**

#### **■ Items to Check Before Turning ON the Power**

- Checking Power Supply Voltage
  - Check to be sure that the power supply voltage is within the ranges shown below.  
R7D-ZP□□H (Single-phase 200-V AC input)  
Main-circuit power supply: Single-phase 200/230 V AC (170 to 253 V) 50/60 Hz
- Checking Terminal Block Wiring
  - The main-circuit power supply inputs (L1/L2) must be properly connected to the terminal block.
  - The Servomotor's red (U), white (V), and blue (W) power lines and the yellow/green ground wire (⊕) must be properly connected to the terminal block.
- Checking the Servomotor
  - There should be no load on the Servomotor. (Do not connect to the mechanical system.)
  - The Servomotor's power lines and Servomotor Power Cable must be connected securely.
  - The Encoder Cable must be securely connected to the Encoder Connector (CN2) at the Servo Driver.
  - The Encoder Cable must be securely connected to the Encoder Connector at the Servomotor.
- Checking the Control Connectors
  - The Control Cable must be securely connected to the I/O Control Connector (CN1).
  - The RUN command (RUN) must be OFF.

#### **■ Turning ON Power**

- First carry out the preliminary checks, and then turn ON the main circuit power supply.
- The ALM output will take approximately 2 seconds to turn ON after the power has been turned ON. Do not attempt to detect an alarm using the Host Controller during this time (when power is being supplied with the Host Controller connected).

#### **■ Checking Displays**

- Once the power has been turned ON, check that the command indicator (REF) is lit orange or green.
- If the command indicator is orange, turn ON the RUN command input (RUN) and check that the indicator changes from orange to green.
- If the indicator does not change to green or one of the alarm indicators is lit (AL1 to AL3), refer to *Section 6 Troubleshooting* and correct the error.

## 5-3 Preparing for Operation

### 5-3-1 Turning ON the Power and Checking Indicators

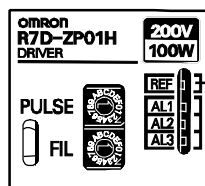

Check that the command indicator is lit orange or green.

## **5-4 Trial Operation**

Once mounting, wiring, switch setting, and connecting a power supply have been finished and normal status has been confirmed, perform trial operation. The main purpose of trial operation is to confirm that the servo system is operating correctly electrically. First no-load operation and then loaded operation is checked.

- Note 1. If an error occurs during the trial operation, refer to *Section 6 Troubleshooting* to eliminate the cause. Then check for safety, reset the alarm, and then retry the trial operation.
2. If the machine vibrates when starting or stopping, refer to *5-2 Switch Settings* and adjust the command filter.

### **5-4-1 Preparing for Trial Operation**

#### **■ Switch Settings**

After turning OFF the power supply, set the following switches.

- Set the rotary switch setting for command pulse (PULSE) to the same setting as the Host Controller.
- Set the command filter rotary switch (FIL) to 0.

#### **■ Turning OFF the Servomotor**

Set up the system so that the power and the RUN command can be turned OFF so that the Servomotor can be immediately turned OFF if an abnormality occurs in the system.

### **5-4-2 Trial Operation**

#### 1) No-load Operation

- Turn ON the power supply to the control circuits, main circuits, and peripheral devices.
- Turn ON the RUN command.
- Check that Servomotor is ON.
- Send a command from the Host Controller to rotate the Servomotor and confirm that Servomotor rotation direction is correct and that the rotation speed and rotation amount match the command that was sent.

#### 2) Power OFF, Mechanical Device Connection, Power ON

- Turn OFF the power supply.
- Connect the mechanical device to the Servomotor shaft.
- Turn ON the power supply.

#### 3) Loaded Low-speed Operation

- Send a low-speed command from the Host Controller to rotate the Servomotor. (The definition of low speed varies depending on the mechanical system, but a rough estimate is 1/10 to 1/5 of the normal operating speed.)
- Check the following items.
  - Is the emergency stop operating correctly?
  - Are the limit switches operating correctly?
  - Is the operating direction of the machinery correct?
  - Are the operating sequences correct?
  - Are there any abnormal sounds or vibration?
  - Is any error (or alarm) generated?

## **5-4 Trial Operation**

### **5-4-2 Trial Operation**

- Note 1. If anything abnormal occurs, refer to *Section 6 Troubleshooting* and apply the appropriate countermeasures.
2. If the machine vibrates when starting or stopping, refer to *5-2-2 Switch Functions* and adjust the command filter rotary switch setting (FIL).

#### **4) Operation under Actual Conditions**

Operate the Servomotor in a regular pattern and check the following items.

- Is the operating speed correct?
- Is the load torque roughly equivalent to the measured value?
- Are the positioning points correct?
- When an operation is repeated, is there any discrepancy in positioning?
- Are there any abnormal sounds or vibration?
- Is either the Servomotor or the Servo Driver abnormally overheating?
- Is any error (or alarm) generated?

- Note 1. If anything abnormal occurs, refer to *Section 6 Troubleshooting* and apply the appropriate countermeasures.
2. If the machine vibrates when starting or stopping, refer to *5-2-2 Switch Functions* and adjust the command filter rotary switch setting (FIL).

#### **5) Completing the Trial Operation**

Performing the above procedures completes the trial operation.

# 5-5 Operating Functions

## 5-5-1 Brake Interlock

### ■ Precautions When Using the Electromagnetic Brake

The electromagnetic brake of a Servomotor with a brake is a non-excitation brake especially for holding. First stop the Servomotor and then turn OFF the brake power supply. If the brake is applied while the Servomotor is operating, the brake disk may become damaged or malfunction due to friction, causing damage to the Servomotor.

### ■ Function

Output the BKIR (brake interlock) signal, which turns the electromagnetic brake ON and OFF.

### ■ Operation

#### ● RUN Command Timing (When Servomotor Is Stopped)

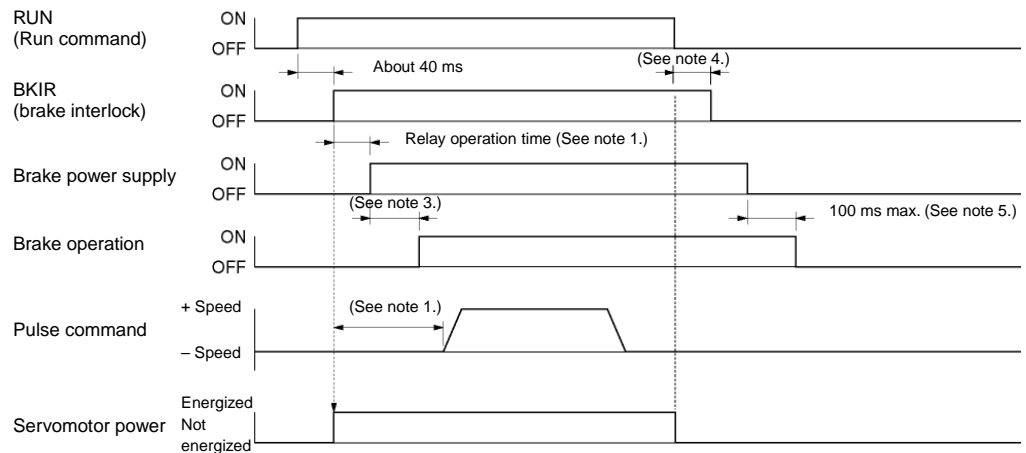

- Note 1. The timechart above shows the time it takes from inputting the Run command (RUN) until the brake being released. Take this delay into account when sending the pulse command, so that the pulse command is sent after the brake has been released. In addition, there is some delay between a change in the BKIR signal and the brake power switching, so check the relay's response time.
2. The time from turning OFF the brake power supply to the brake engaging is 100 ms max.
3. The time from turning ON the brake power supply to the brake being released depends on the Servomotor being used. The following table shows the delay for each model.

Model	Delay
R7M-Z10030-B	60 ms max.
R7M-Z20030-B	
R7M-Z40030-B	
R7M-Z75030-B	80 ms max.

4. Refer to the following page for the stop sequence.
5. The brake's operation time depends on the model of surge suppressor installed on the brake.

## 5-5 Operating Functions

### 5-5-1 Brake Interlock

#### ● RUN Command Timing (When Servomotor Is Rotating)

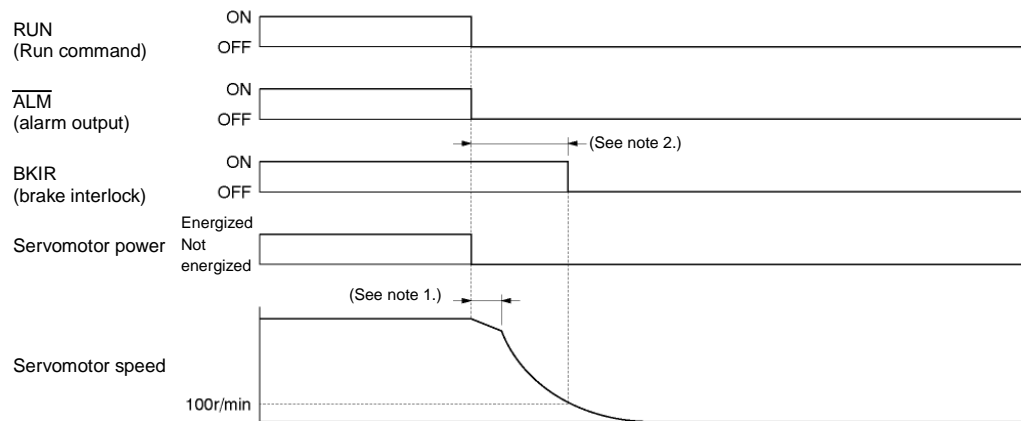

- Note 1. The Servomotor will continue to rotate due to its momentum for about 15 ms after the Servomotor de-energizes until the dynamic brake operates.
2. The BKIR (brake interlock) signal will be turned OFF if the Servomotor rotation speed falls below 100 r/min or 500 ms has elapsed since the Servo went OFF.

## **Section 6**

# **Troubleshooting**



## 6-1 Error Processing

### 6-1-1 Preliminary Checks when a Problem Occurs

# 6-1 Error Processing

## 6-1-1 Preliminary Checks when a Problem Occurs

This section explains the preliminary checks and analytical tools required to determine the cause of a problem if one occurs.

### ■ Checking the Power Supply Voltage

- Check the voltage at the power supply input terminals.  
Main-circuit Power Supply Input Terminals (L1, L2)  
Single-phase 200/230 V AC (170 to 253 V) 50/60 Hz  
If the voltage is outside of this range, there is a risk of incorrect operation, so be sure that the power supply is correct.
- Check the voltage of the sequence input power supply and verify that the +24 VIN Terminal (pin CN1-5) is within the allowed range of 23 to 25 VDC. If the voltage is outside of this range, there is a risk of malfunction, so be sure that the power supply is correct.

### ■ Checking Whether an Alarm Has Occurred

Check the alarm indicators (AL1 to AL3) on the front of the Servo Driver to see whether an alarm has occurred.

- Checking Whether an Alarm Has Occurred
  - When an alarm is indicated:  
Check the status of the alarm indicators (AL1 to AL3) and evaluate the problem based on the alarm indicated.
  - When an alarm is not indicated:  
Evaluate the problem with the error information.

Note: In either case, refer to 6-3 *Troubleshooting* for details.

## **6-1-2 Precautions When Troubleshooting**

When checking and verifying I/O after a problem has occurred, the Servo Driver may suddenly start to operate or suddenly stop, so always take the following precautions. In addition, never attempt operations that are not specified in this manual.

### **■ Precautions**

- Disconnect any cables before checking whether they are broken or damaged. Even if you have checked the conduction of the wiring, there is a risk of conduction due to the return circuit.
- If the encoder signal is lost, the Servomotor may overrun, or an error may be generated. Be sure that the Servomotor is disconnected from the mechanical system before checking the encoder signal.
- When performing tests, first check that there are no personnel in the vicinity of the mechanical equipment, and that the equipment will not be damaged even if the Servomotor overruns. Before performing the tests, verify that you can immediately stop the machine using an emergency stop even if the Servomotor overruns.

## **6-1-3 Replacing the Servomotor and Servo Driver**

Use the following procedure to replace the Servomotor or Servo Driver.

### **■ Replacing the Servomotor**

- (1) Replace the Servomotor.
- (2) Perform origin teaching.
  - When the Servomotor is replaced, the Servomotor's specific origin position (Z-phase) may slip, so origin teaching must be performed.
  - Refer to the Position Controller's manual for details on performing origin teaching.

### **■ Replacing the Servo Driver**

- (1) Replace the Servo Driver.
- (2) Match the previous switch settings.
  - Set the new Servo Driver's switches (command pulse setting rotary switch and command filter setting rotary switch) to match the old Servo Driver's switch settings.

























## 6-2 Alarm Table

### 6-2-1 Alarm Table

# 6-2 Alarm Table

If the Servo Driver detects an error, ALM (alarm output) will be output, the power drive circuit in the Servo Driver will be turned OFF, and the alarm code will be displayed. Refer to *6-3-1 Error Diagnosis using the Alarm Indicators* for details on appropriate alarm countermeasures.

### 6-2-1 Alarm Table







LED Indicators	ALM output	Error detection function	Cause of error
AL1  AL2  AL3 	OFF	Speed error (Overspeed)	A speed error occurs if the Servomotor's speed exceeds 1.1 times the maximum speed (4,950 rpm). Either reduce the position command's speed or correct the command pulse resolution.
AL1  AL2  AL3 	OFF	Overload	This error occurs when the Servomotor's torque exceeds the range of the overload characteristics (electronic thermal function). Check the load, review the acceleration/deceleration time, and check for Servomotor vibration.
AL1  AL2  AL3 	OFF	Encoder error	This error occurs when data cannot be read from the Encoder or the expected differential-phase signal is not present. Check the cables.
AL1  AL2  AL3 	OFF	Voltage error	This error occurs if the voltage between P-N is outside of the acceptable range of 170 to 410 V during operation. Check whether the input voltage is between 170 and 253 V.
AL1  AL2  AL3 	OFF	Overcurrent	This error occurs when the current exceeds the power module's maximum allowable current or the temperature in the module exceeds the allowed level. Check for shorted outputs, ground problems, or insufficient Servo Driver cooling/air circulation.
AL1  AL2  AL3 	OFF	Servo Driver fan stopped	This error occurs when the Servo Driver's built-in axle fan stopped. Replace the fan.
AL1  AL2  AL3 	OFF	System error	An internal MPU error occurred. Replace the Unit.
AL1  AL2  AL3  Flashing steadily	---	Command pulse setting rotary switch (PULSE) changed	Displayed when the setting on the front panel's command pulse setting rotary switch was changed. This is not an alarm.

Lit:  Not lit:  Flashing: 

# 6-3 Troubleshooting

If an error occurs in the machinery, determine the error conditions from the alarm indicators and operating status, identify the cause of the error, and take appropriate countermeasures.









## 6-3-1 Error Diagnosis using the Alarm Indicators

LED Indicators	Error	Status when error occurs	Cause of error	Countermeasure
AL1  AL2  AL3 	Speed error	Occurs when the power is turned ON.	The Servo Driver is faulty.	Replace the Servo Driver.
		Occurs when the servo is turned ON.	The U phase, V phase, W phase, or GR wires are wired incorrectly.	Rewire correctly.
			The encoder wires are wired incorrectly.	
			Noise infiltrated the Encoder Cable and caused improper operation.	Take countermeasures against noise in the Encoder Cable.
			The Servo Driver is faulty.	Replace the Servo Driver.
		Occurs when the Servomotor starts running or after initiating high-speed rotation.	The U phase, V phase, W phase, or GR wires are wired incorrectly.	Rewire correctly.
			The encoder wires are wired incorrectly.	
			Noise infiltrated the Encoder Cable and caused improper operation.	Take countermeasures against noise in the Encoder Cable.
			The position command input exceeds a rate of 4,500 rpm.	Input the command value correctly.
			The Servo Driver is faulty.	Replace the Servo Driver.
AL1  AL2  AL3 	Overload	Occurs when the power is turned ON.	The Servo Driver is faulty.	Replace the Servo Driver.
		Occurs when the servo is turned ON.	The U phase, V phase, W phase, or GR wires are wired incorrectly.	Rewire correctly.
			The encoder wires are wired incorrectly.	
			The Servo Driver is faulty.	Replace the Servo Driver.
		Servomotor will not rotate even though command pulses are being input.	The U phase, V phase, W phase, or GR wires are wired incorrectly.	Rewire correctly.
			The encoder wires are wired incorrectly.	
			The Servomotor shaft is locked.	Check the load status and re-evaluate the Servomotor capacity.
			The Servo Driver is faulty.	Replace the Servo Driver.
		Occurs during normal operation.	Operation continued with an effective torque exceeding the rated torque, within the electronic thermal function's operation range.	Re-evaluate the load conditions and conditions, or re-evaluate the Servomotor capacity.
			Power supply voltage dropped.	Keep the power supply voltage within the allowed range.
			Servomotor winding is burned out.	Measure the winding resistance and replace the Servomotor if the winding is burned out.

Lit:  Not lit:  Flashing: 

## 6-3 Troubleshooting













### 6-3-1 Error Diagnosis using the Alarm Indicators

LED Indicators	Error	Status when error occurs	Cause of error	Countermeasure
AL1  AL2  AL3 	Overload (Continued)	Occurs during normal operation. (Continued)	Operated while the holding brake was engaged.	Measure the voltage at the brake terminals and release the brake.
			The ambient Servo Driver temperature exceeds 55°C.	Review the installation conditions so that the Servo Driver's ambient temperature is below 55°C.
			There is a problem with the Servo Driver's installation environment, such as the installation direction, spacing between Units, or surroundings.	
		The Servo Driver is faulty.	Replace the Servo Driver.	
		Occurs when the servo is turned OFF.	The Servomotor did not stop even though 3 seconds passed after the servo was turned OFF.	Re-evaluate the load conditions. Check whether an external force is rotating the Servomotor.
AL1  AL2  AL3 	Encoder error	Occurs when the power is turned ON or during operation.	The encoder cable is wired incorrectly or the connector is loose.	Check the wiring.
			Noise is infiltrating the cable because the encoder cable does not meet specifications.	Use an encoder cable with twisted-pair wires or shielded twisted-pair wires that are at least 0.12 mm <sup>2</sup> (26 AWG).
			Noise is infiltrating the encoder cable because the cable is too long.	Shorten the encoder cable to less than 20 m.
			The encoder cable is broken.	Replace the encoder cable.
			Origin error	Replace the Servomotor.
			Faulty encoder	
			AL1  AL2  AL3 	Voltage error
The Servo Driver's power was turned ON again before it was completely turned OFF.	Wait until the REF Indicator is OFF before turning ON the power supply again.			
The Servo Driver is faulty.	Replace the Servo Driver.			
Occurs during normal operation.	There was a large voltage change in the main circuit power supply.	Keep the power supply voltage within the allowed range.		
	The motor is rotating at high speed and the load inertia is too large.	Re-evaluate the load and operating conditions.		
	An external Regeneration Resistance Unit is not connected or the wrong external Regeneration Resistor was selected.	Calculate the regenerative energy, and connect an external Regeneration Resistance Unit or Regeneration Resistor with sufficient capacity.		
	The Servo Driver is faulty.	Replace the Servo Driver.		

Lit:  Not lit:  Flashing: 

## 6-3 Troubleshooting

### 6-3-1 Error Diagnosis using the Alarm Indicators

LED Indicators	Error	Status when error occurs	Cause of error	Countermeasure
AL1  AL2  AL3 	Overcurrent	Occurs when the power is turned ON or during operation.	The U phase, V phase, W phase, or GR wires are wired incorrectly or the connections are loose.	Rewire correctly.
			The GR terminal is linked to another terminal.	
			The following lines are shorted or interconnected: <ul style="list-style-type: none"> <li>Interconnection of a U, V, or W phase in Servomotor Power Cable and ground</li> <li>Interconnection between U, V, or W phases in Servomotor Power Cable</li> </ul>	Repair or replace the Servomotor Power Cable Caution: Before turning on the power, always verify that there are no short-circuits or interconnected lines.
			The external Regeneration Resistance Unit is wired incorrectly.	Rewire correctly.
			The following lines are shorted or interconnected: <ul style="list-style-type: none"> <li>Interconnection of a Servomotor U, V, or W phase and ground</li> <li>Servomotor U, V, or W phases</li> </ul>	Replace the Servomotor.
			The load is too large and exceeds the regenerative absorption capacity.	Re-evaluate the load and operating conditions.
			There is a problem with the Servo Driver's installation environment, such as the installation direction, spacing between Units, or surroundings.	Review the installation conditions so that the Servo Driver's ambient temperature is below 55°C.
			The Servo Driver's cooling is insufficient.	Improve air circulation and heat-dissipation.
			The Servomotor and Servo Driver combination is incorrect.	Use compatible models.
			The Servo Driver is faulty.	Replace the Servo Driver.
Servomotor is burned out.	Replace the Servomotor.			
AL1  AL2  AL3 	Servo Driver fan stopped	Occurs when the power is turned ON or during operation.	The Servo Driver's built-in cooling fan stopped.	Replace the cooling fan. (Refer to 6-5 <i>Periodic Maintenance</i> for details.)
AL1  AL2  AL3 	System error	Occurs when the power is turned ON.	The Servo Driver is faulty.	Replace the Servo Driver.
AL1  AL2  AL3  Flashing steadily	Command pulse setting rotary switch (PULSE) changed	Occurs when the power is turned ON or during operation.	The command pulse setting rotary switch was changed during operation.	Turn the power supply OFF and ON again.

Lit:  Not lit:  Flashing: 

## 6-3 Troubleshooting

### 6-3-2 Error Diagnosis using the Operating Status

#### 6-3-2 Error Diagnosis using the Operating Status

Problem	Likely cause	Items to check	Countermeasures
The power indicator (PWR) does not light when the power supply is turned ON.	The power supply cable is wired incorrectly.	Check whether the power supply input is within the allowed voltage range.	Supply the correct power.
		Check whether the power supply input is wired correctly.	Wire correctly.
	The external Regeneration Resistance Unit is wired incorrectly.	Check whether the external Regeneration Resistance Unit's cable is wired correctly.	Replace the Servo Driver and external Regeneration Resistance Unit and wire them correctly.
	Servomotor will not rotate even though command pulses are being input from the Controller.	The Run command (RUN) is OFF.	Check whether the REF Indicator is lit green.
The command pulse setting is incorrect.		Check whether the REF Indicator is flashing.	If the REF Indicator is flashing: <ul style="list-style-type: none"> <li>Wire the input correctly.</li> <li>Set the Servo Driver's pulse type to match the Controller's command pulse type.</li> </ul>
	Check the Controller's command pulse type and the Servo Driver's command pulse type.	Set the Servo Driver's pulse type to match the Controller's command pulse type.	
The Servomotor Power Cable is wired incorrectly.	Check the wiring.	Wire correctly.	
	The Encoder Cable is wired incorrectly.		
The Control I/O Connector (CN1) is wired incorrectly.	Check the command pulse's wiring.	Wire correctly.	
	Check the command pulse type.	Set the Servo Driver's pulse type to match the Controller's command pulse type.	
The power supply is not ON.	Check the command pulse's voltage.	Connect a resistor that matches the voltage.	
	The power supply is not ON.	Check whether the power supply is ON and check the PWR Indicator.	Turn ON the power supply.
The CW input and CCW input are ON at the same time.	Check the voltage across the power supply terminals.	Set up the power supply's ON circuit correctly.	
	Check the command pulse's wiring.	<ul style="list-style-type: none"> <li>Input either the CW input or CCW input to the pulse signal.</li> <li>Always turn OFF the terminal that is not being input.</li> </ul>	
Servo Driver is faulty.	---	Replace the Servo Driver.	
The Servomotor operates momentarily, but then it does not operate.	The Servomotor Power Cable or Encoder Cable is wired incorrectly.	Check the wiring of the Servomotor Power Cable's U, V, and W phases and check the Encoder Cable's wiring.	Wire correctly.
The Servomotor rotates without a command.	The command pulse input is incorrect.	Check the command pulse type.	Set the correct command pulse input.
		Check the command pulse's voltage.	Connect a resistor that matches the voltage.
Servo Driver is faulty.	---	Replace the Servo Driver.	
The Servomotor rotates in the opposite direction from the command.	The CW input and CCW input connections are reversed.	Check the Controller's command pulse type and the Servo Driver's command pulse type.	Connect the CW pulse signal to the CW input and the CCW pulse signal to the CCW input.

## 6-3 Troubleshooting

### 6-3-2 Error Diagnosis using the Operating Status

Problem	Likely cause	Items to check	Countermeasures
Servomotor operation is unstable.	The Servomotor Power Cable or Encoder Cable is wired incorrectly.	Check the wiring of the Servomotor Power Cable's U, V, and W phases and check the Encoder Cable's wiring.	Wire correctly.
	There coupling system between the Servomotor shaft and the mechanical system has eccentricities or looseness, or the torque is fluctuating due to varying engagement between pulleys or gears.	Check the mechanical system's coupling section.	Review and adjust the machinery.
		Try operating the Servomotor without a load. (Disconnect it from the mechanical system.)	
	The load's moment of inertia exceeds the Servo Driver's allowed value.	Try operating the Servomotor without a load. (Disconnect it from the mechanical system.)	<ul style="list-style-type: none"> <li>• Lighten the load.</li> <li>• Replace the Servomotor and Servo Driver with higher capacity Units.</li> </ul>
	The pulse signal line's connections are loose.	Check the pulse signal wiring at the Controller and Servo Driver.	Wire correctly.
Check the Controller's command pulse type and the Servo Driver's command pulse type.		Set the Servo Driver's pulse type to match the Controller's command pulse type.	
Servomotor is overheating.	The ambient temperature is too high.	Verify that the ambient temperature around the Servomotor is below 40°C.	Lower the ambient temperature to 40°C or less. (Use a cooler or fan.)
	Ventilation is obstructed.	Check to see whether anything is blocking ventilation.	Improve ventilation.
	The Servomotor is overloaded.	Try operating the Servomotor without a load. (Disconnect it from the mechanical system.)	<ul style="list-style-type: none"> <li>• Lighten the load.</li> <li>• Replace the Servomotor and Servo Driver with higher capacity Units.</li> </ul>
	The Servomotor is vibrating.		
The holding brake is ineffective.	Power is being supplied to the holding brake.	Check whether power is being supplied to the holding brake.	Configure a circuit that cuts power to the holding brake when the motor stops and the load will be held by the holding brake.
The Run command (RUN) is turned OFF while the Servomotor is rotating, but the Servomotor doesn't stop or is hard to stop.	The load inertia is too large.	Check the following: <ul style="list-style-type: none"> <li>• Is the load too large?</li> <li>• Is the Servomotor speed too high?</li> </ul>	Re-evaluate the load conditions and replace the Servo Driver with an appropriate model if necessary.
	The stop circuit failed.	---	Replace the Servo Driver.



## 6-3 Troubleshooting

### 6-3-2 Error Diagnosis using the Operating Status

Problem	Likely cause	Items to check	Countermeasures
The Servomotor is producing unusual noises or the machinery is vibrating.	There are problems with the machinery's installation.	Check whether the Servomotor's mounting screws are loose.	Tighten the mounting screws.
		Check whether the axes are misaligned in the mechanical coupling system.	Align the mechanical couplings.
		Check whether the couplings are unbalanced.	Adjust the coupling's balance.
	There is a problem with the bearings.	Check for noise or vibration around the bearings.	Contact your OMRON representative.
	Noise is infiltrating the Control I/O Cable because the cable does not meet specifications.	Check that the cable wires are twisted-pair wires or shielded twisted-pair wires that are at least 0.08 mm <sup>2</sup> (28 AWG).	Use Control I/O Cable that meets specifications.
	Noise is infiltrating the Control I/O Cable because the cable is too long.	Check the length of the Control I/O Cable.	Shorten the Control I/O Cable to less than 3 m.
	Noise is infiltrating the cable because the encoder cable does not meet specifications.	Check that the cable wires are twisted-pair wires or shielded twisted-pair wires that are at least 0.12 mm <sup>2</sup> (26 AWG).	Use encoder cable that meets specifications.
	Noise is infiltrating the encoder cable because the cable is too long.	Check the length of the encoder cable.	Shorten the encoder cable to less than 20 m.
	Noise is infiltrating the signal wires because the encoder cable is damaged or the sheath is cut.	Check the encoder cable for cuts or other damage.	Correct the encoder cable's pathway to prevent damage.
	Too much noise is reaching the encoder cable.	Separate the encoder cables far from high-current lines or check whether the lines are too close.	Install the encoder cable where it won't be subjected to surges.
	The FG's potential is fluctuating due to devices near the Servomotor, such as welding machines.	Check for ground problems (loss of ground or incomplete ground) at equipment such as welding machines near the Servomotor.	Ground the equipment properly and prevent currents flowing to the Encoder FG.
	Errors are being caused by excessive vibration or shock on the encoder.	There are problems with mechanical vibration or motor installation (such as the mounting surface, attachment, or axial offset).	Reduce the mechanical vibration or correct the Servomotor's installation.
	The filter setting is not suitable.	Check the setting on the command filter setting rotary switch (FIL).	Increase the value set on the command filter setting rotary switch (FIL).

## 6-4 Overload Characteristics (Electronic Thermal Function)

An overload protection (electronic thermal) function is built into the Servo Driver to protect against Servo Driver and Servomotor from overloading. If an overload does occur, first eliminate the cause of the error and then wait at least one minute for the Servomotor temperature to drop before turning on the power again. If the power is turned ON again repeatedly at short intervals, the Servomotor windings may burn out.

The overload characteristics are for a Servomotor with an aluminum heat sink (250 × 250 × 6 mm) mounted and an ambient temperature of 40°C, so use the Servomotor under these conditions.

### 6-4-1 Overload Characteristics Graphs

The following graphs show the characteristics of the load rate and electronic thermal function's operation time.

#### ■ R7D-ZP01H Servo Driver (100 W)

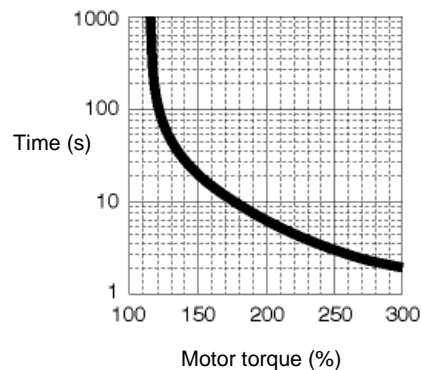

- Note 1. The motor torque (%) indicates the percentage of the rated torque that is applied.  
 Note 2. For example, if the motor torque is 300% of the rated torque, an overload alarm will be generated after about 2 seconds when an R7D-ZP01H is being used.

#### ■ R7D-ZP02H/-ZP04H/-ZP08H Servo Drivers (200 W to 750 W)

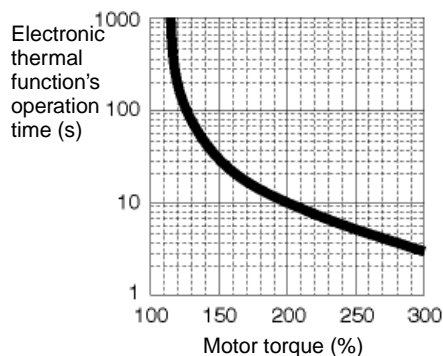

- Note 1. The motor torque (%) indicates the percentage of the rated torque that is applied.  
 Note 2. For example, if the motor torque is 300% of the rated torque, an overload alarm will be generated after about 3 seconds.

## 6-5 Periodic Maintenance

### 6-5-1 Servomotor Maintenance

# 6-5 Periodic Maintenance

Servomotors and Servo Drivers contain many components and will operate properly only when each of the individual components is operating properly. Some of the electrical and mechanical components require maintenance depending on application conditions. Periodic inspection and part replacement are necessary to ensure proper long-term operation of Servomotors and Servo Drivers.

The periodic maintenance cycle depends on the installation environment and application conditions of the Servomotor or Servo Driver. Recommended maintenance times are listed below for Servomotors and Servo Drivers. Use these for reference in determining actual maintenance schedules.

 **Caution**

 Resume operation only after transferring all data required for operation to the new Unit. Not doing so may result in an unexpected operation.

 Do not attempt to disassemble, repair, or modify any Units. Any attempt to do so may result in malfunction, fire, or electric shock.

### 6-5-1 Servomotor Maintenance

The recommended periodic maintenance schedule is listed below.

- Bearings: 20,000 hours
- Decelerator: 20,000 hours

These values presume an ambient Servomotor operating temperature of 40°C, shaft loads within the allowable range, rated operation (rated torque and rated r/min), and proper installation as described in the *Operation Manual*.

- The radial loads during operation (rotation) on timing pulleys and other components contacting belts is twice the still load. Consult with the belt and pulley manufacturers and adjust designs and system settings so that the allowable shaft load is not exceeded even during operation. If a Servomotor is used under a shaft load exceeding the allowable limit, the Servomotor shaft can break, the bearings can burn out, and other problems can occur.
- When requesting repairs or investigations, separate the Servomotors and Decelerators, and make separate requests for each product.

## 6-5-2 Servo Driver Maintenance

The recommended periodic maintenance schedule is listed in the following table. Please consult with your OMRON representative to determine whether or not components need to be replaced.

Aluminum electrolytic capacitors	50,000 hours, at an ambient Servo Driver operating temperature of 40°C, 80% of the rated operation output (rated torque), installed as described in operation manual.
Axle fan	30,000 hours, at an ambient Servo Driver operating temperature of 40°C and an ambient humidity of 65%.

- When using the Servo Driver in continuous operation, use fans or air conditioners to maintain an ambient operating temperature below 40°C.
- We recommend that ambient operating temperature and the power ON time be reduced as much as possible to lengthen the maintenance intervals for Servo Drivers.
- The life of aluminum electrolytic capacitors is greatly affected by the ambient operating temperature. Generally speaking, an increase of 10°C in the ambient operating temperature will reduce capacitor life by 50%.
- The aluminum electrolytic capacitors deteriorate even when the Servo Driver is stored with no power supplied. If the Servo Driver is not used for a long time, we recommend a periodic inspection and part replacement schedule of five years.
- If the Servomotor or Servo Driver is not to be used for a long time, or if they are to be used under conditions worse than those described above, a periodic inspection schedule of five years is recommended.

## 6-5-3 Replacing the Cooling Fan

Please contact your OMRON representative regarding cooling fan replacement.

**6-5 Periodic Maintenance**  
*6-5-3 Replacing the Cooling Fan*

# Appendix

---

# A-1 Connection Examples

## Example 1: Connecting to SYSMAC CJ1W-NC133/233/433 Position Control Units

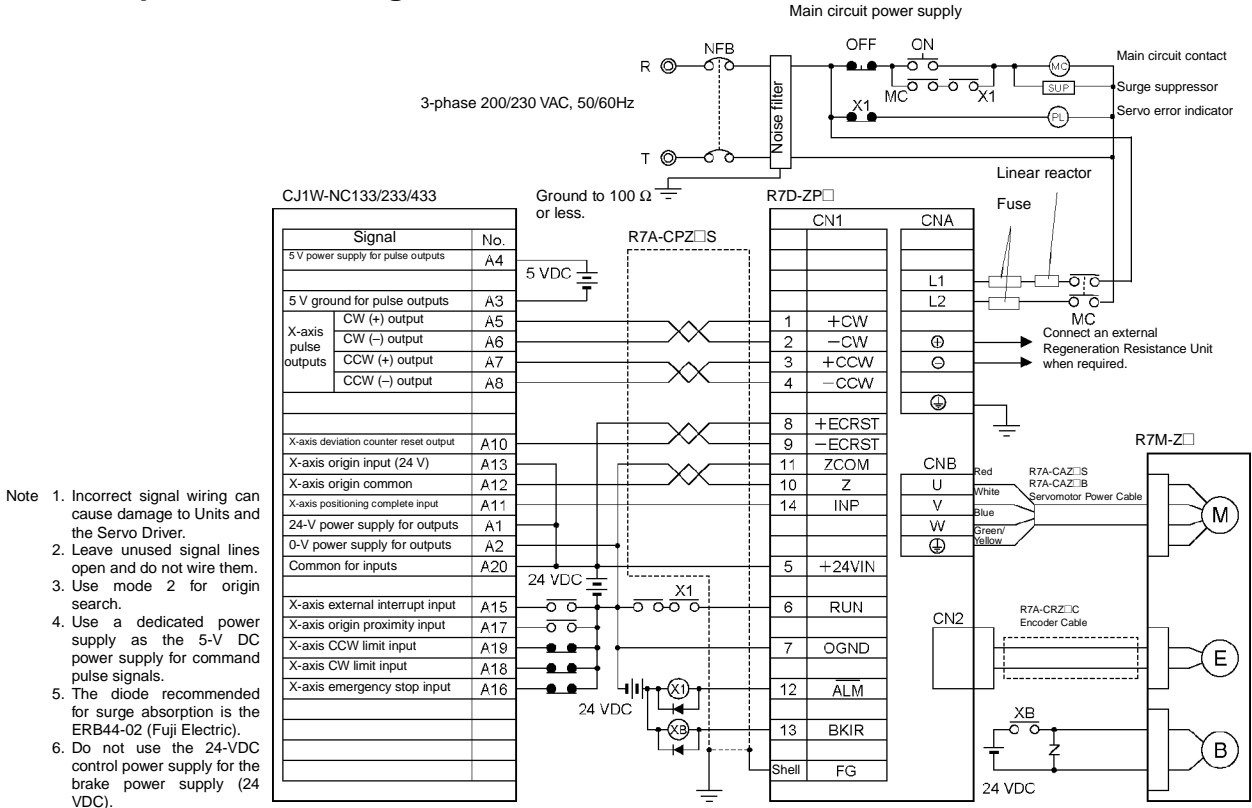

## Example 2: Connecting to SYSMAC CJ1W-NC113/213/413 Position Control Units

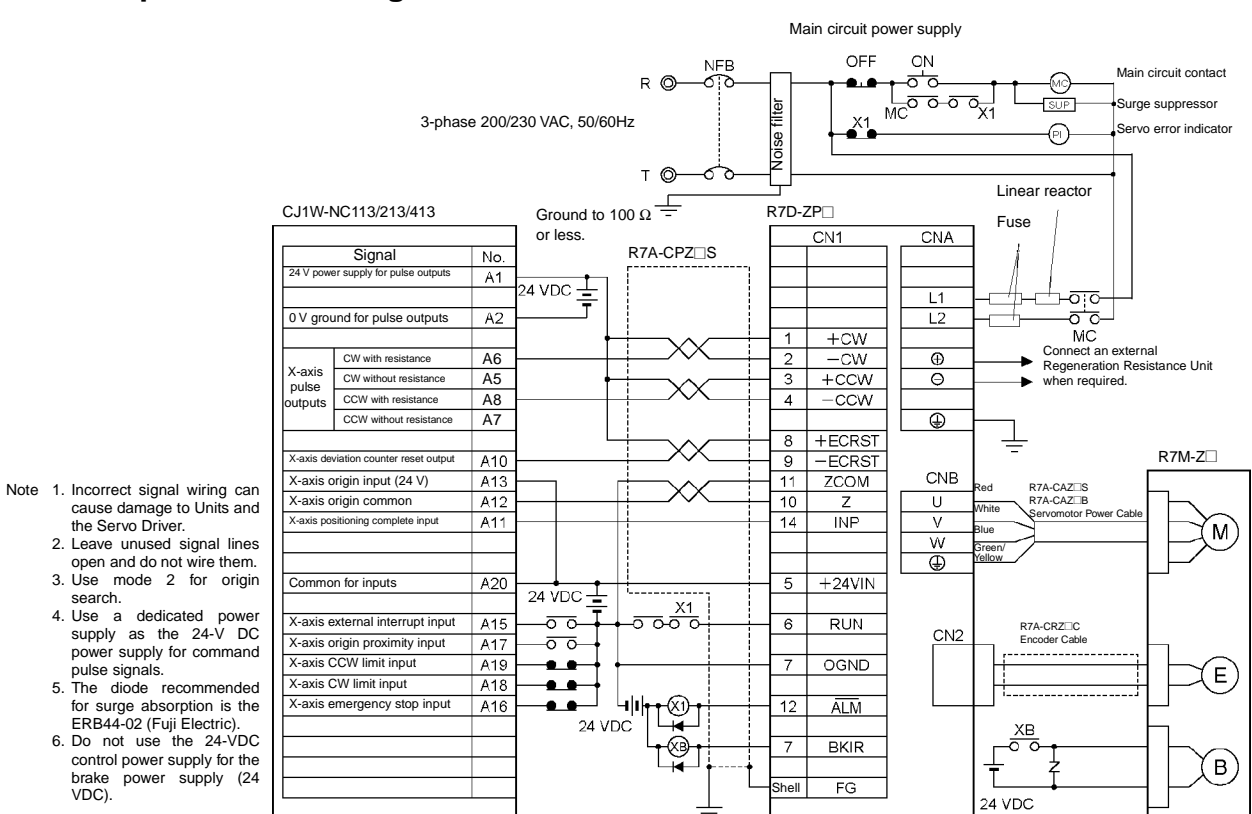





## A-1 Connection Examples

### Example 5: Connecting to SYSMAC CS1W-NC133/233/433 Position Control Units

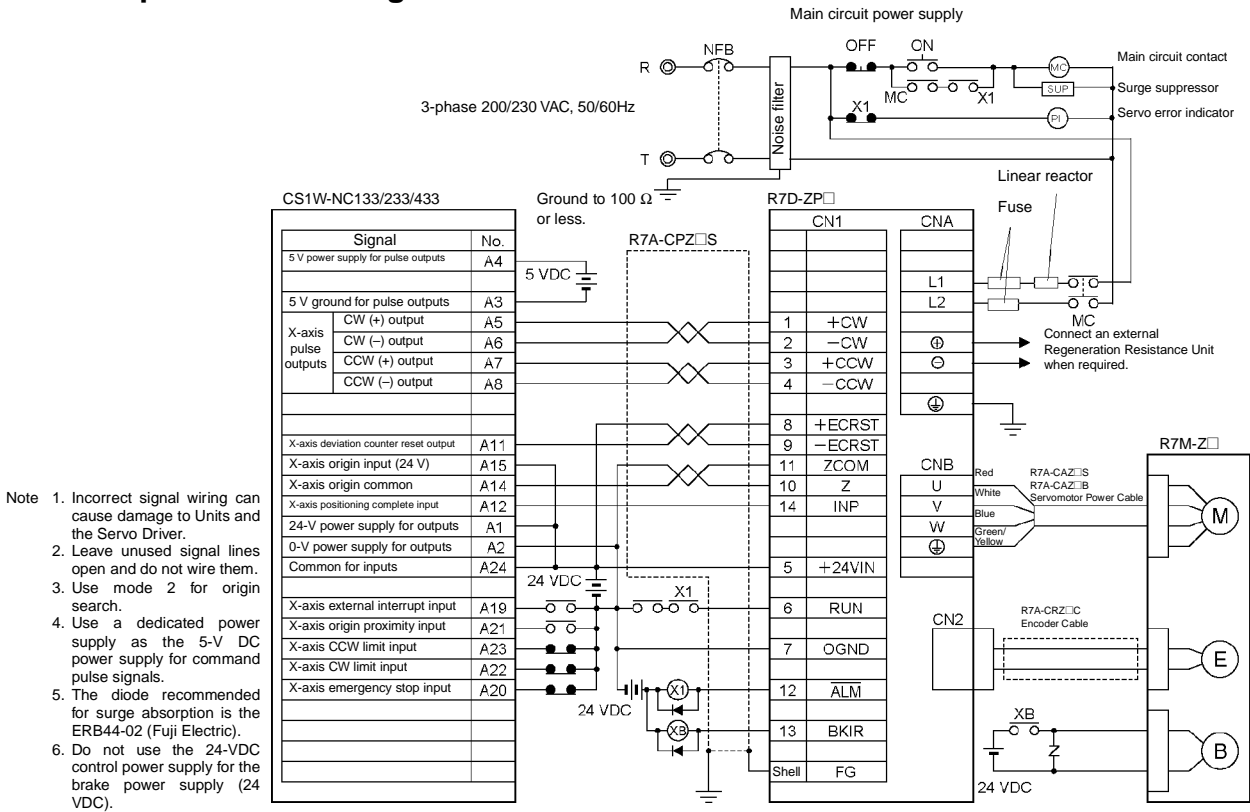

### Example 6: Connecting to SYSMAC CS1W-NC113/213/413 and C200HW-NC113/213/413 Position Control Units

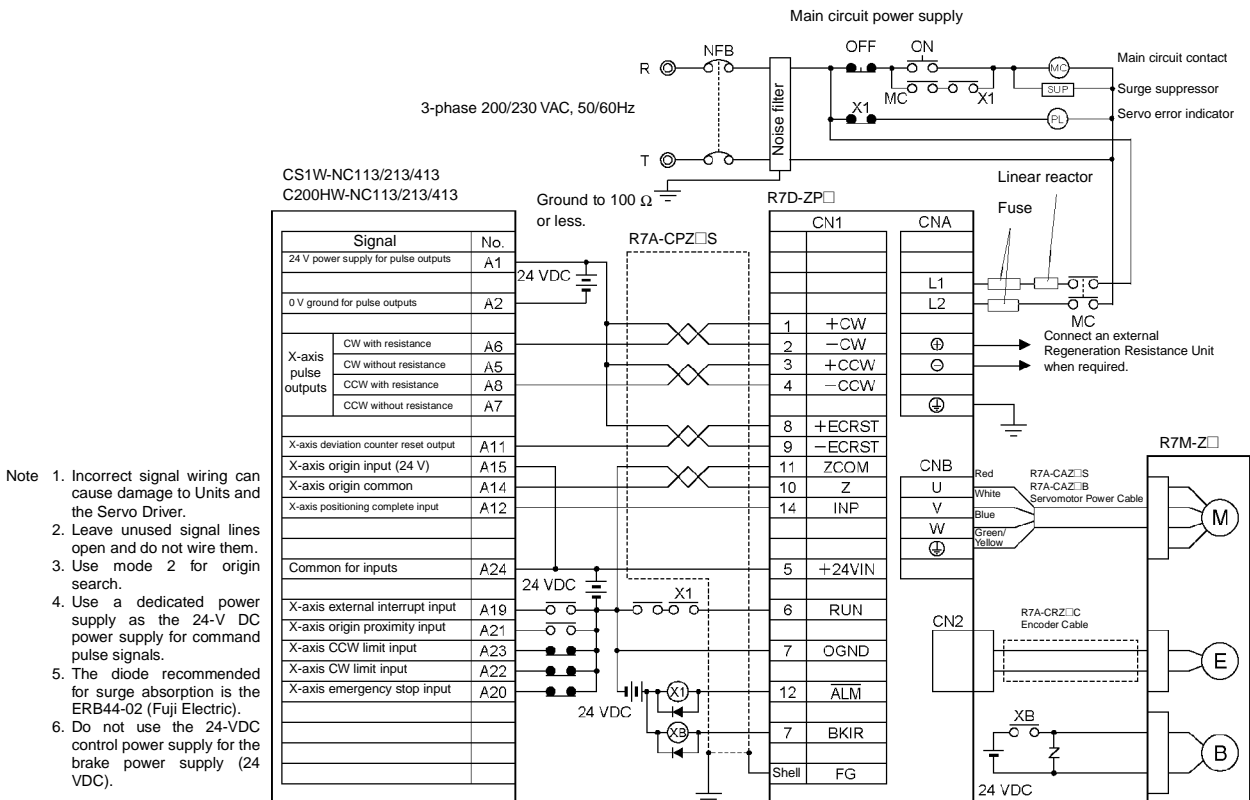

■ Example 7: Connecting to a SYSMAC C200H-NC112 Position Control Unit

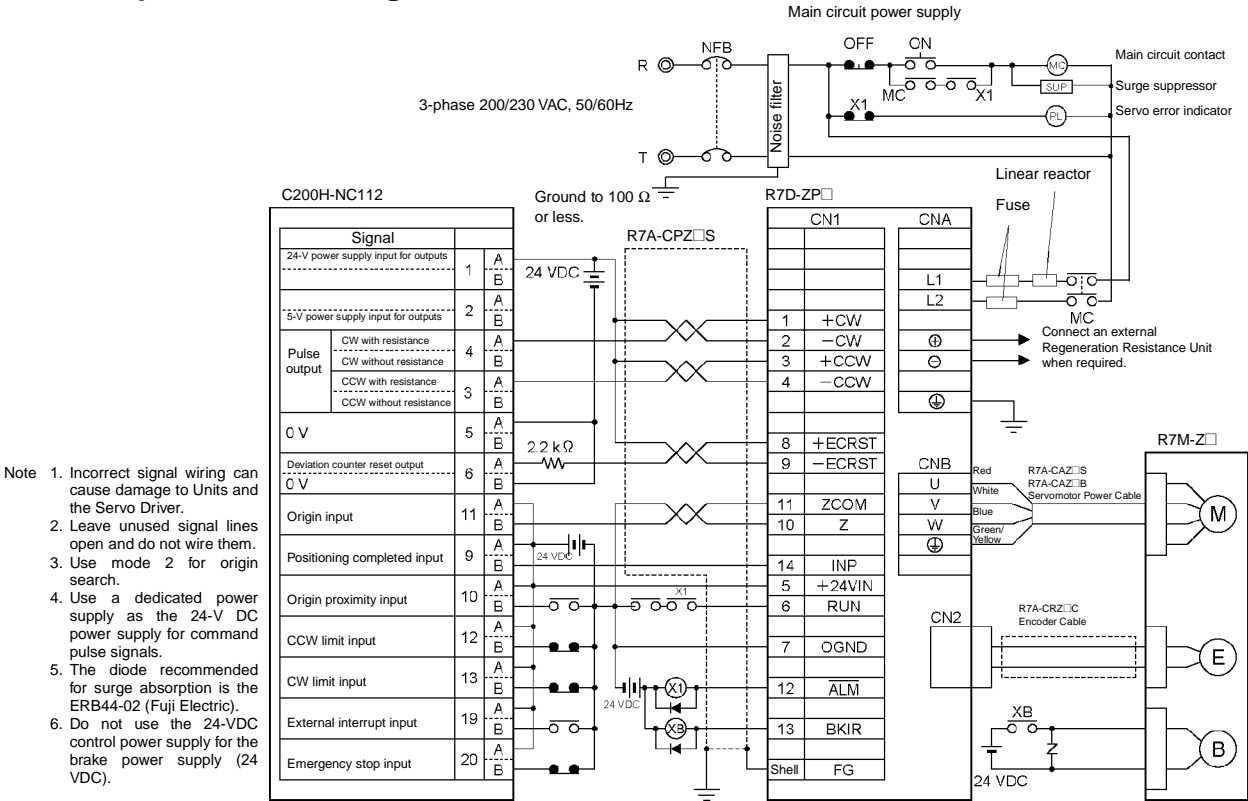

■ Example 8: Connecting to a SYSMAC C200H-NC211 Position Control Unit

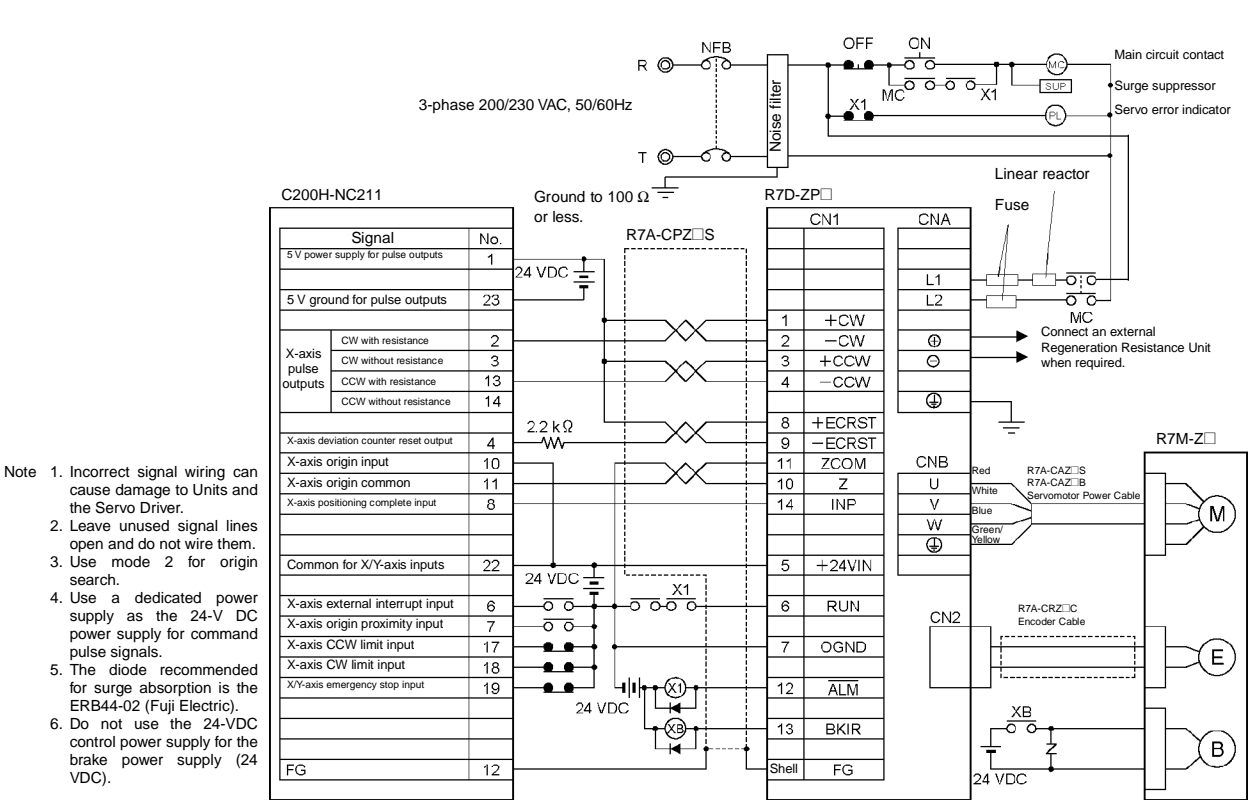

# A-1 Connection Examples

## Example 9: Connecting to an FQM1-MMP21 Motion Controller

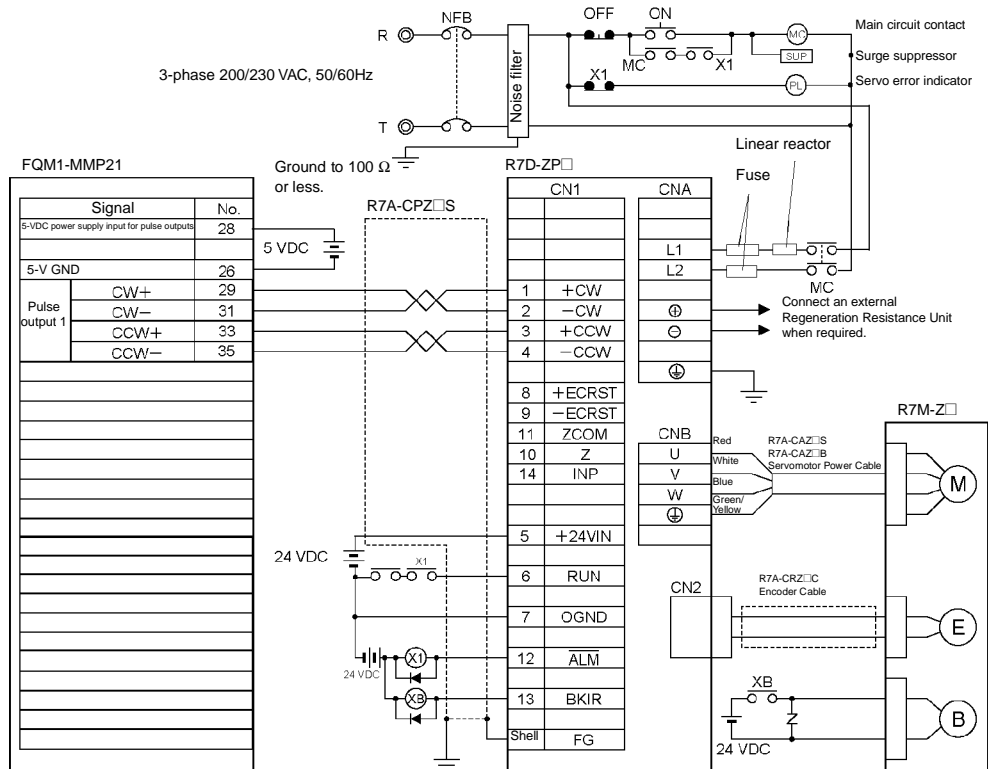

- Note
1. Incorrect signal wiring can cause damage to Units and the Servo Driver.
  2. Leave unused signal lines open and do not wire them.
  3. Use a dedicated power supply as the 24-V DC power supply for command pulse signals.
  4. The diode recommended for surge absorption is the ERB44-02 (Fuji Electric).
  5. Do not use the 24-VDC control power supply for the brake power supply (24 VDC).

## Example 10: Connecting to a SYSMAC CPM2C PLC

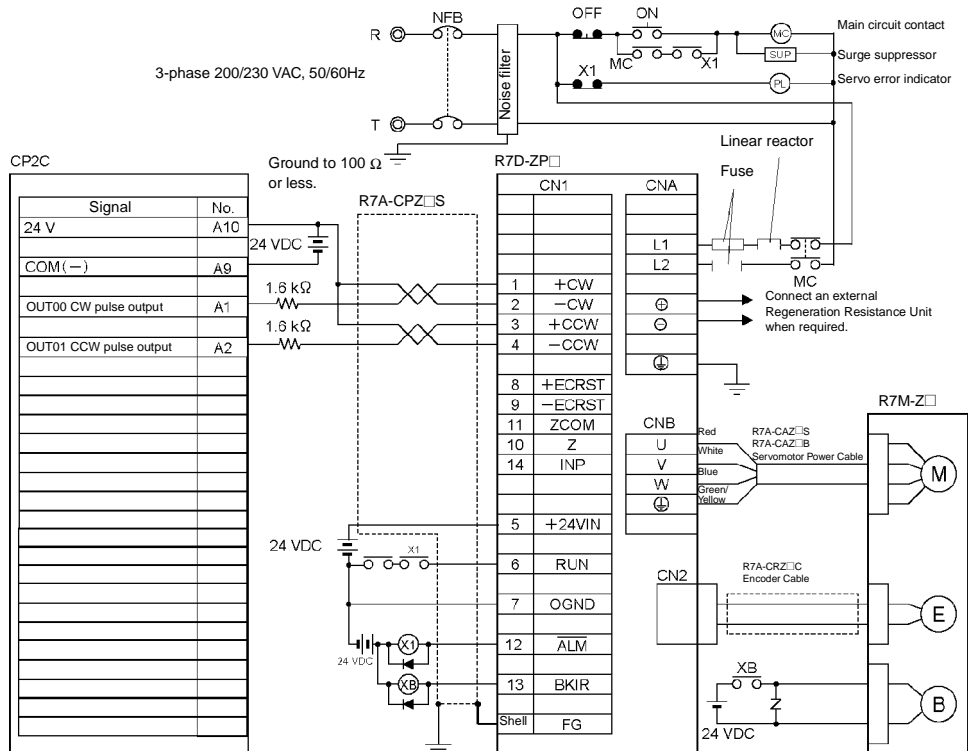

- Note
1. Incorrect signal wiring can cause damage to Units and the Servo Driver.
  2. Leave unused signal lines open and do not wire them.
  3. Use a dedicated power supply as the 24-V DC power supply for command pulse signals.
  4. The diode recommended for surge absorption is the ERB44-02 (Fuji Electric).
  5. Do not use the 24-VDC control power supply for the brake power supply (24 VDC).

# Revision History

A manual revision code appears as a suffix to the catalog number on the front cover of the manual.

Cat. No. I553-E1-01



Revision code

The following table outlines the changes made to the manual during each revision. Page numbers refer to the previous version.

Revision code	Date	Revised content
01	September 2006	Original production

**OMRON Corporation**  
**Control Devices Division H.Q.**  
Shiokoji Horikawa, Shimogyo-ku,  
Kyoto, 600-8530 Japan  
Tel: (81)75-344-7109/Fax: (81)75-344-7149

**Regional Headquarters**

**OMRON EUROPE B.V.**  
Wegalaan 67-69, NL-2132 JD Hoofddorp  
The Netherlands  
Tel: (31)2356-81-300/Fax: (31)2356-81-388

**OMRON ELECTRONICS LLC**  
1 East Commerce Drive, Schaumburg, IL 60173  
U.S.A.  
Tel: (1)847-843-7900/Fax: (1)847-843-8568

**OMRON ASIA PACIFIC PTE. LTD.**  
83 Clemenceau Avenue,  
#11-01, UE Square,  
Singapore 239920  
Tel: (65)6835-3011/Fax: (65)6835-2711

**OMRON (CHINA) CO., LTD.**  
Room 2211, Bank of China Tower,  
200 Yin Cheng Zhong Road,  
PuDong New Area, Shanghai, 200120 China  
Tel: (86)21-5037-2222/Fax: (86)21-5037-2200

# OMRON

**Authorized Distributor:**