

Compact, High-performance Micro Displacement Sensor

- Meets various needs with high performance at the resolution of 5 μm .
- Numerous applications are possible when the analog output model is integrated with OMRON's K3TX Intelligent Signal Processors.
- ON/OFF output model (NPN open collector) is available.



Ordering Information

■ Z4D-F

Output	Model
Analog	Z4D-F04A
ON/OFF	Z4D-F04D

■ Accessories (Attached)

Item	Z4D-F04A	Z4D-F04D
Mounting bracket	1 pc.	1 pc.
Mounting screws (M3 x 2)	2 pcs.	2 pcs.
Connector with 1-m cord	1 pc.	1 pc.
Screwdriver	---	1 pc.
Operation Manual	1 copy	1 copy

Specifications

■ Ratings/Characteristics

Item	Z4D-F04A	Z4D-F04D
Supply voltage	12 to 24 VDC±10%, ripple voltage (p-p): 10 mV max.	
Current consumption	35 mA max.	
Sensing range (see note 1)	4±1.25 mm	
Light source	Red LED with a wavelength of 700 nm	
Spot diameter (see note 2)	1.5 x 1.5 mm max. (at the sensing range of 4 mm)	
Connection impedance (see note 3)	200 kΩ min.	---
Resolution (see note 4)	5 μm max.	---
Hysteresis (see note 1)	---	40 μm
Linearity (see note 5)	±1% FS	---
Analog output (see note 1)	1 to 5 V (1.6 V/mm±10%)	---
Control output	---	NPN open collector, 12 to 24 VDC, 50 mA max.
Residual output voltage	---	1 V max.
Response time (see note 6)	5 ms max.	1.5 ms max.
Temperature influence (see note 7)	0.15% FS/°C	---
Indicator	PWR indicator (green): Lit when power is supplied ALM indicator (red): Lit when illumination is insufficient.	STB indicator (green): Lit when illumination is sufficient. OPE indicator (orange): Lit when output is ON.
Ambient temperature	Operating: -10°C to 55°C (with no icing) Storage: -15°C to 60°C (with no icing)	
Ambient humidity	Operating: 35% to 85% (with no icing)	
Ambient illumination	Operating: 3000 lx max. (incandescent lamp), 10,000 lx max. (sunlight)	
Enclosure rating	IP50 (IEC standard)	
Vibration resistance	Destruction: 10 to 500 Hz (1-mm max. single amplitude) for 11 min for 3 times each in X, Y, and Z directions	
Shock resistance	Destruction: 500 m/s ² for 3 times each in X, Y, and Z directions (total of 18 times)	
Dielectric strength	1,000 VAC for 1 min between current carry parts and case	
Tightening torque	0.6 N·m max.	
Material	ABS (Polycarbonate for the sensing part)	
Weight	Approx. 10 g (without connector cable)	
Insulation resistance	20 MΩ min. (at 500 VDC)	
Cable length	1 m	

Note: 1. The values are for N8.5 Munsell paper.

2. The spot diameter is defined by $1/e^2$ of the Sensor's laser beam center. Although a sub-beam may be observed around the main beam, this does not mean that the product is defective.
3. Refers to input impedance of a device to be connected.

4. Resolution (Z4D-F04A)

The resolution is the peak-to-peak displacement conversion value of the analog displacement output (Conditions: N8.5 Munsell mat paper at the center of measurement point with a power ripple noise of 10 mV (p-p) max.)

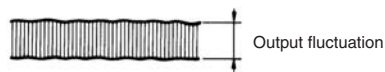

5. The value is the peak-to-peak error rate of a displacement output voltage line with N8.5 Munsell mat paper. The value varies with the sensing object.

6. Response Time (Z4D-F04A)

The response time of the Sensor (Z4D-F04A) is the time required for the analog displacement output to increase from 10% to 90% of the full value (at the rise time) or decrease from 90% to 10% of the full value (at the fall time).

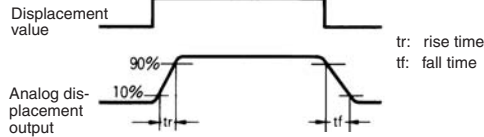

The response time of the Sensor (Z4D-F04D): ON/OFF switching time

7. The value is at the sensing range of 4 mm.

Engineering Data

■ Characteristics Data

Analog Output Model (Z4D-F04A)

Sensing Distance vs. Analog Output Characteristics (Typical)

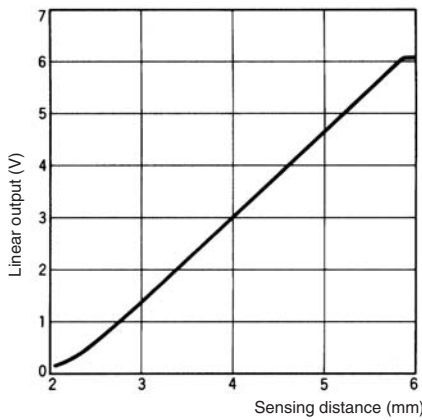

Angle Characteristics with Difference in Horizontal Inclination

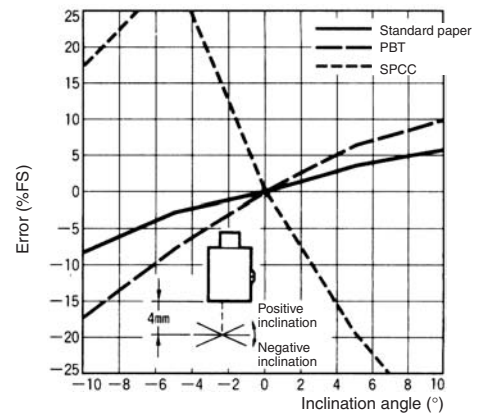

Angle Characteristics with Difference in Vertical Inclination

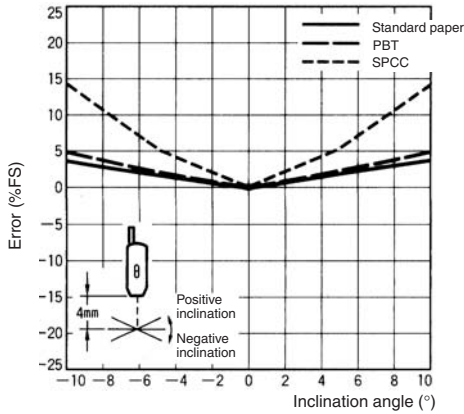

Analog Output Characteristics with Difference in Sensing Object

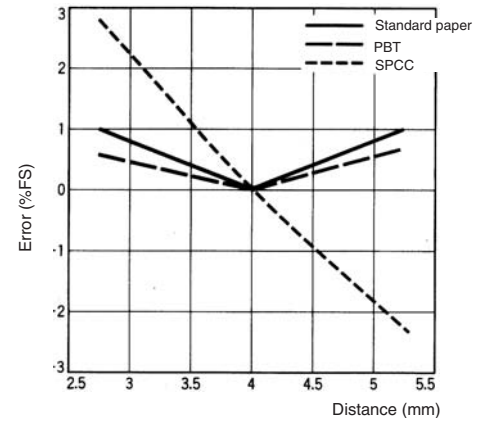

Temperature Characteristics

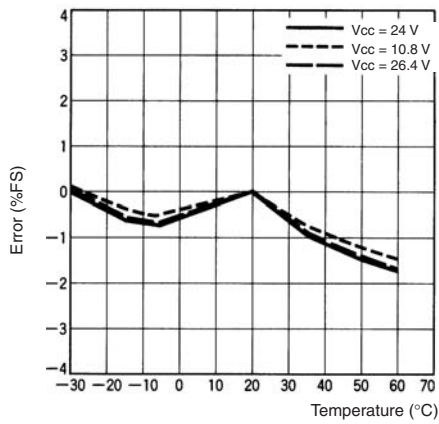

Resolution Characteristics with Difference in Reflection Rate

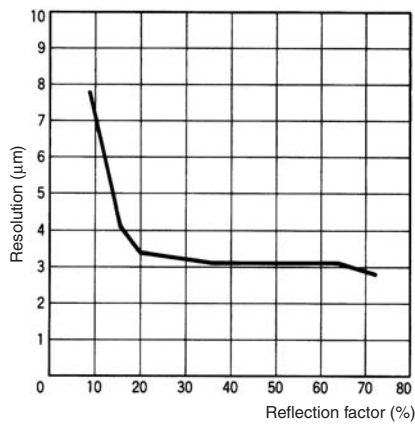

ON/OFF Output Model (Z4D-F04D)

Sensing Distance vs. Adjustor Angle Characteristics

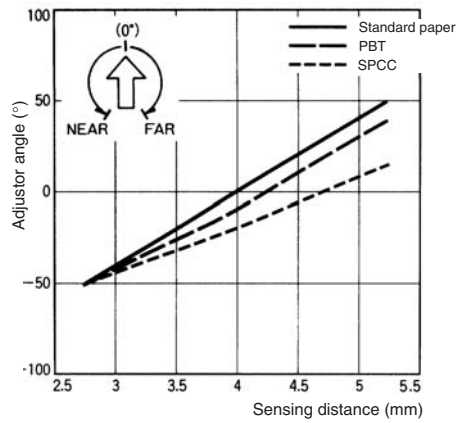

Note: The PBT plastic referred in this data was detected under its natural state.

Nomenclature

■ Analog Output (Z4D-F04A)

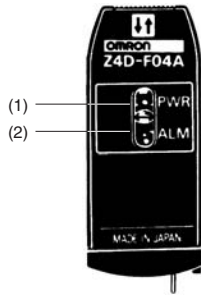

(1) Power (PWR) Indicator

The green PWR indicator is lit when power is properly supplied to the Sensor.

(2) Alarm (ALM) Indicator

The red ALM indicator is lit if there is no sensing object or the reflectivity of the sensing object is low and it is impossible for the Sensor to process the light reflected to the Sensor. The indicator is lit when the amount of light is less than what is required for computation by the Sensor. When the ALM indicator is lit, make necessary adjustments so that the indicator turns OFF.

Appropriate amount of light:	Not lit
Insufficient amount of light:	Lit in red

■ ON/OFF Output (Z4D-F04D)

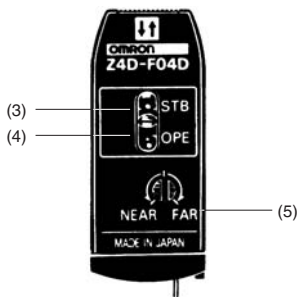

(3) Stability (STB) Indicator

The green STB indicator is lit when the Sensor is receiving sufficient light to process. If the indicator is not lit, adjust the amount of light to turn on the indicator.

(4) Operation (OPE) Indicator

The Sensor is synchronized with the ON/OFF output and the orange OPE indicator is lit when the Sensor has ON output.

(5) Distance Adjustor

The ON/OFF position can be set with the distance adjustor if a sensing object is at the sensing range (i.e., 4 ± 1.25 mm). The ON/OFF position will shift farther from the Sensor if the distance adjustor is turned clockwise and the ON/OFF position will shift closer to the Sensor if the distance adjustor is turned counter-clockwise.

Operation

■ Connections/Output Circuits

Analog Output

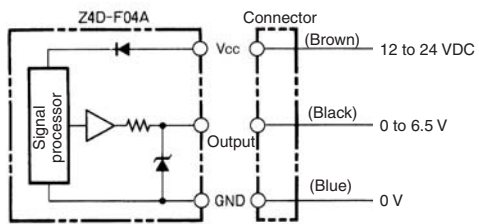

NPN Open Collector Output

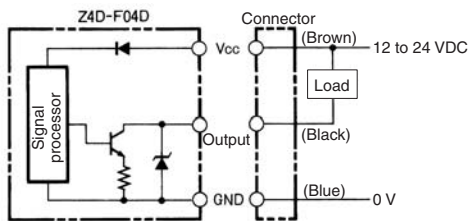

Dimensions

■ Z4D-F04A

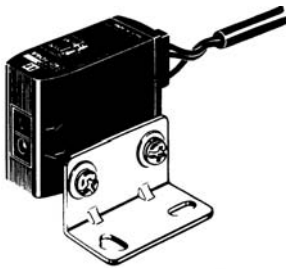

Mounting bracket can be attached to this side.

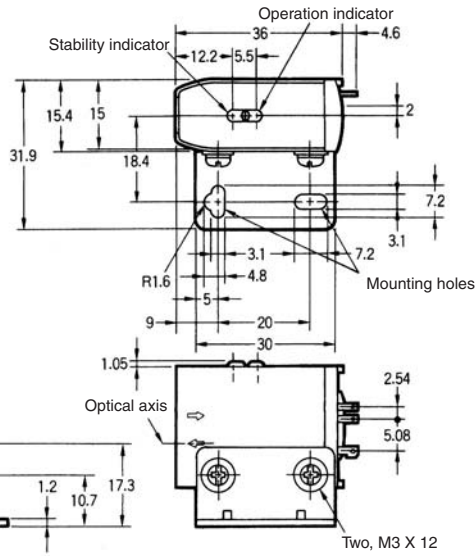
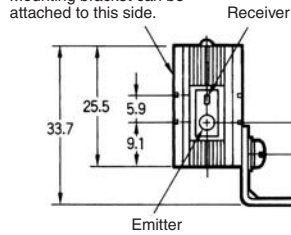

Mounting Holes

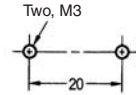

■ Z4D-F04D

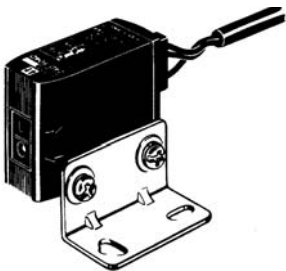

Mounting bracket can be attached to this side.

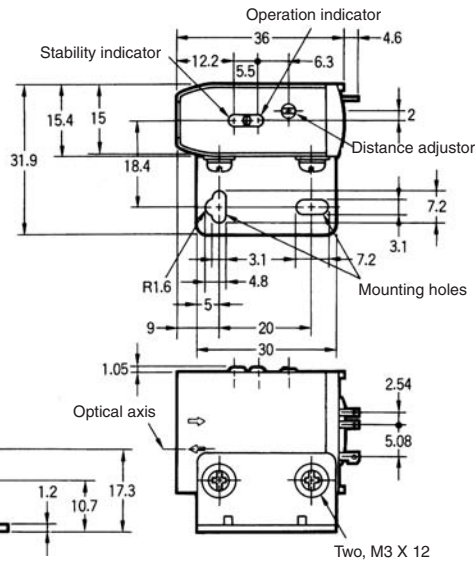
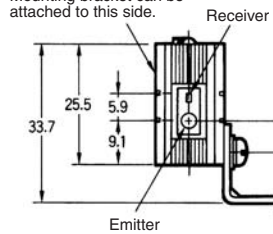

Mounting Holes

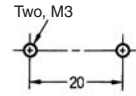

■ Accessories

The following products are provided with the Sensors. The products can also be purchased separately.

E39-L69 Mounting Bracket

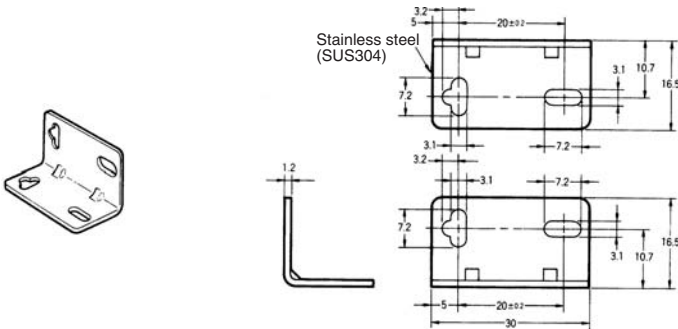

EE-1010D Connector with 1-m Cord

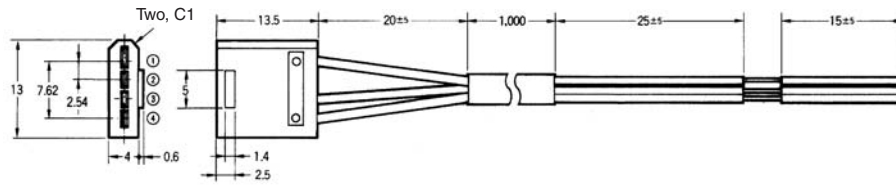

Terminal Arrangement

No.	Designation	Color
1	Vcc	Brown (red)
2	---	---
3	Output	Black (white)
4	GND	Blue (black)

Installation

■ Controller Connections

Z4D-F04A and K3TX-VD

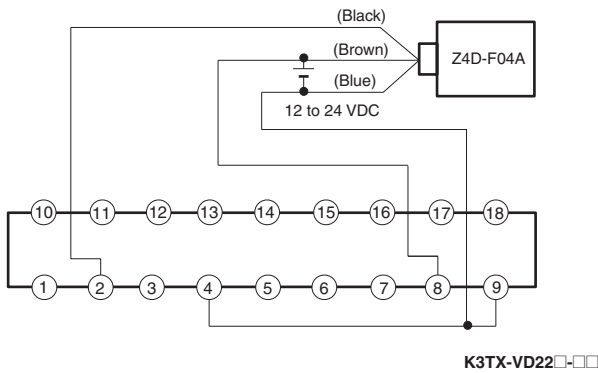

- Note:**
1. Use a K3TX DC voltage input model.
 2. K3TX models are available in various output units. Select the most appropriate K3TX model depending on the application.
 3. For details about the K3TX, refer to the *K3TX Datasheet*.
 4. The diagram shown here is for a K3TX model with DC power specifications. When using a K3TX with AC power specifications, separate the AC power supply to the K3TX from the DC power supply to the Z4D-F04A.

Z4D-F04D and S3D2

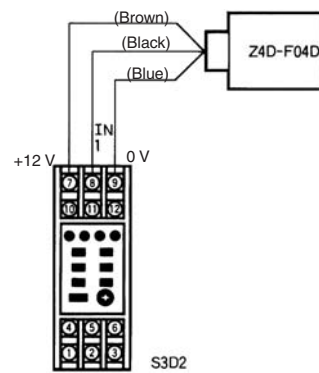

- Note:** Reverse operation is possible with the signal input selector of the S3D2.

Caution

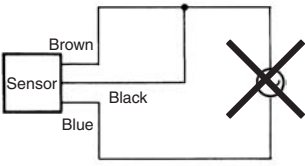
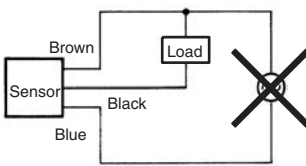
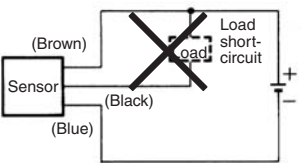
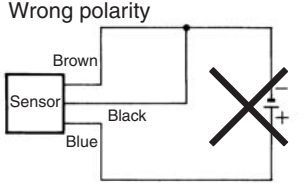
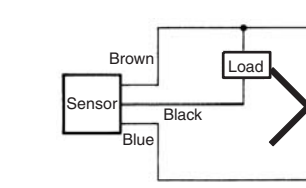
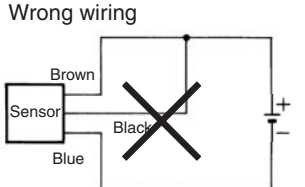
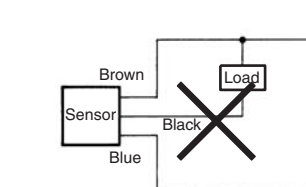
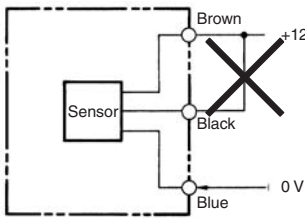
Item	Examples	
<p>Power supply Do not impose an excessive voltage on the Z4D-F, otherwise it may explode or burn. Do not impose 100 VAC on any Z4D-F model, otherwise it may explode or burn.</p>	<p>Incorrect</p> 	<p>Incorrect</p> 
<p>Load short-circuit Do not short-circuit the load, or the Z4D-F may explode or burn.</p>	<p>Incorrect</p> 	
<p>Wiring Be sure to wire the Z4D-F correctly and be careful not to connect the polarities incorrectly, otherwise it may explode or burn.</p>	<p>Wrong polarity Incorrect</p> 	<p>Incorrect</p> 
	<p>Wrong wiring Incorrect</p> 	<p>Incorrect</p> 
<p>Connection with no load If connected to the power supply without any load, internal elements may explode or burn. Make sure to connect a proper load to the Z4D-F.</p>	<p>Incorrect</p> 	

■ Correct Use

Mounting

Install the Sensor so that the optical axis of the Sensor and the surface of the object meet at right angles (i.e., the panel that incorporates the light source is parallel with the object). For accurate results, it is recommended that the sensing distance is set to the measurement point (4 mm).

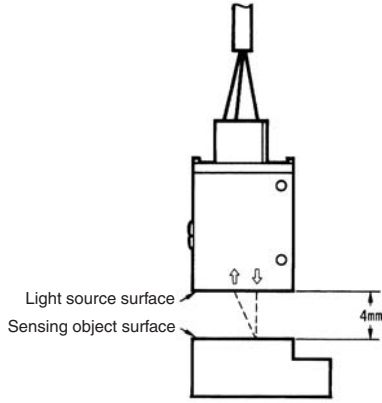

Note: As the optical axis will be adjusted later, temporarily fix the Sensor.

Wiring

Connect the Sensor to the controlling device using an attached sensor cable. Do not switch the power ON during wiring. Refer to the instructions on the Sensor and the connection diagram (page 8) before connecting the Sensor to the controlling device.

Axis Adjustment

When the Sensor power is switched ON, the red transmitter indicator is lit. Move the Sensor so that the red beam (see the figure below) focuses on the object. The entire light beam should be focused on the object or an error will result.

After the optical axis has been adjusted, tighten the mounting screws firmly.

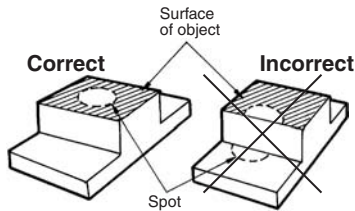

Z4D-F04A

Analog Output

The Z4D-04A has an output of 3 V if a sensing object is located at the standard distance (i.e., 4 ± 0.3 mm). The output decreases if the sensing object is closer to the Sensor and the output increases if the sensing object is farther from the Sensor. The output changes by $1.6 \text{ V} \pm 10\%$ if the sensing object moves by 1 mm. The standard upper and lower limits of the output are 6.5 and 0 V respectively. If there is no sensing object or the reflectivity of the sensing object is low and no light is reflected to the Sensor, the analog output will output the standard upper limit.

Analog Output Diagram

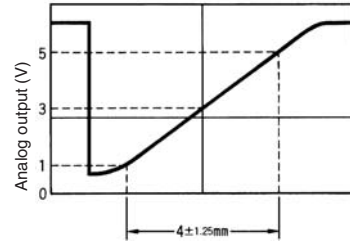

Z4D-F04D

ON/OFF Output Diagram

The ON/OFF position can be set with the distance adjuster if a sensing object is at the sensing range (i.e., 4 ± 1.25 mm). The ON/OFF position will shift farther from the Sensor if the distance adjuster is turned clockwise and the ON/OFF position will shift closer to the Sensor if the distance adjuster is turned counter-clockwise.

If there no sensing object is present or if the reflectivity from a sensing object is too small to reach the Sensor, the output will turn OFF.

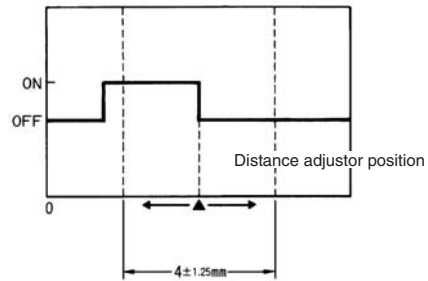

Precautions

Install the Sensor in a clean environment keep the filter (on the front of the Sensor) free from oil and dust. If affected by oil or dust, clean the Sensor as follows:

1. Use a blower brush (used to clean camera lenses) to blow large dust particles from the surface. Do not blow the dust away with your mouth.
2. Use a soft cloth (for lenses) with a little alcohol to remove the remaining dust.
Do not use a scrubbing action when cleaning as a scratch on the filter could result in the Sensor malfunctioning.

Connector

When removing the connector from the Sensor, be sure to hold the connector and pull it together with the attached cable.

If pulled by the cable alone, it will damage the lock mechanism inside the connector.

Interference

Z4D-F04A/D Micro Displacement Sensors can be installed within close proximity to each other and operate independently without interference (refer to the figures below). However, if they are installed at an oblique angle to each other, interference may result.

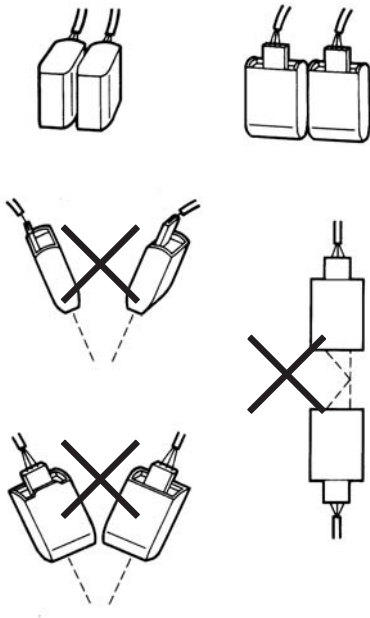

When using the Micro Displacement Sensor in combination with another type of Sensor (such as a Photoelectric Sensor), the sensor beams should be as close to perpendicular as possible.

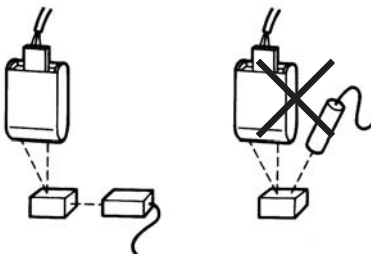

Environment

Refrain from using the Micro Displacement Sensor in a strong electromagnetic field or in an environment where the operation of the Sensor is subject to the reflection of intensive light (such as a laser beam or an electric arc welding machine).

The Displacement Microsensor cannot accurately sense a mirror-like object, a transparent object, one with an extremely small reflection ratio, an object smaller than the diameter of the Sensor's sensing spot, or an inclined object.

Wiring

The power supply cable for the Z4D-F04A/D should not be wired with high-voltage lines or power lines in order to avoid interference, damage, or malfunction.

Do not solder wires to the Sensor connector, otherwise the Sensor may malfunction.

Others

Do not use switching power supplies that generate excessive noise, which may cause sensing errors.

The following LC filter effectively reduces noise.

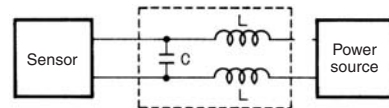

The Sensor cannot sense an object accurately if the surface of the object consists of different materials placed next to each other (refer to the figures below). In such a case install the Sensor so that the boundaries of the materials and the Sensor are parallel.

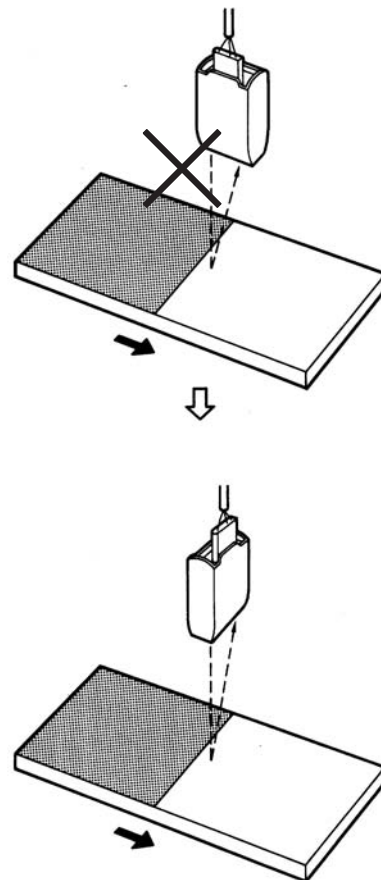

ALL DIMENSIONS SHOWN ARE IN MILLIMETERS.

To convert millimeters into inches, multiply by 0.03937. To convert grams into ounces, multiply by 0.03527.

In the interest of product improvement, specifications are subject to change without notice.

OMRON Corporation

Industrial Automation Company

Sensing Devices Division H.Q.

Application Sensors Division

Shiokoji Horikawa, Shimogyo-ku,

Kyoto, 600-8530 Japan

Tel: (81)75-344-7068/Fax: (81)75-344-7107

Read and Understand This Catalog

Please read and understand this catalog before purchasing the products. Please consult your OMRON representative if you have any questions or comments.

Warranty and Limitations of Liability

WARRANTY

OMRON's exclusive warranty is that the products are free from defects in materials and workmanship for a period of one year (or other period if specified) from date of sale by OMRON.

OMRON MAKES NO WARRANTY OR REPRESENTATION, EXPRESS OR IMPLIED, REGARDING NON-INFRINGEMENT, MERCHANTABILITY, OR FITNESS FOR PARTICULAR PURPOSE OF THE PRODUCTS. ANY BUYER OR USER ACKNOWLEDGES THAT THE BUYER OR USER ALONE HAS DETERMINED THAT THE PRODUCTS WILL SUITABLY MEET THE REQUIREMENTS OF THEIR INTENDED USE. OMRON DISCLAIMS ALL OTHER WARRANTIES, EXPRESS OR IMPLIED.

LIMITATIONS OF LIABILITY

OMRON SHALL NOT BE RESPONSIBLE FOR SPECIAL, INDIRECT, OR CONSEQUENTIAL DAMAGES, LOSS OF PROFITS, OR COMMERCIAL LOSS IN ANY WAY CONNECTED WITH THE PRODUCTS, WHETHER SUCH CLAIM IS BASED ON CONTRACT, WARRANTY, NEGLIGENCE, OR STRICT LIABILITY.

In no event shall responsibility of OMRON for any act exceed the individual price of the product on which liability is asserted.

IN NO EVENT SHALL OMRON BE RESPONSIBLE FOR WARRANTY, REPAIR, OR OTHER CLAIMS REGARDING THE PRODUCTS UNLESS OMRON'S ANALYSIS CONFIRMS THAT THE PRODUCTS WERE PROPERLY HANDLED, STORED, INSTALLED, AND MAINTAINED AND NOT SUBJECT TO CONTAMINATION, ABUSE, MISUSE, OR INAPPROPRIATE MODIFICATION OR REPAIR.

Application Considerations

SUITABILITY FOR USE

OMRON shall not be responsible for conformity with any standards, codes, or regulations that apply to the combination of products in the customer's application or use of the product.

At the customer's request, OMRON will provide applicable third party certification documents identifying ratings and limitations of use that apply to the products. This information by itself is not sufficient for a complete determination of the suitability of the products in combination with the end product, machine, system, or other application or use.

The following are some examples of applications for which particular attention must be given. This is not intended to be an exhaustive list of all possible uses of the products, nor is it intended to imply that the uses listed may be suitable for the products:

- Outdoor use, uses involving potential chemical contamination or electrical interference, or conditions or uses not described in this catalog.
- Nuclear energy control systems, combustion systems, railroad systems, aviation systems, medical equipment, amusement machines, vehicles, safety equipment, and installations subject to separate industry or government regulations.
- Systems, machines, and equipment that could present a risk to life or property.

Please know and observe all prohibitions of use applicable to the products.

NEVER USE THE PRODUCTS FOR AN APPLICATION INVOLVING SERIOUS RISK TO LIFE OR PROPERTY WITHOUT ENSURING THAT THE SYSTEM AS A WHOLE HAS BEEN DESIGNED TO ADDRESS THE RISKS, AND THAT THE OMRON PRODUCT IS PROPERLY RATED AND INSTALLED FOR THE INTENDED USE WITHIN THE OVERALL EQUIPMENT OR SYSTEM.

Disclaimers

CHANGE IN SPECIFICATIONS

Product specifications and accessories may be changed at any time based on improvements and other reasons.

It is our practice to change model numbers when published ratings or features are changed, or when significant construction changes are made. However, some specifications of the product may be changed without any notice. When in doubt, special model numbers may be assigned to fix or establish key specifications for your application on your request. Please consult with your OMRON representative at any time to confirm actual specifications of purchased product.

DIMENSIONS AND WEIGHTS

Dimensions and weights are nominal and are not to be used for manufacturing purposes, even when tolerances are shown.

ERRORS AND OMISSIONS

The information in this catalog has been carefully checked and is believed to be accurate; however, no responsibility is assumed for clerical, typographical, or proofreading errors, or omissions.

PERFORMANCE DATA

Performance data given in this catalog is provided as a guide for the user in determining suitability and does not constitute a warranty. It may represent the result of OMRON's test conditions, and the users must correlate it to actual application requirements. Actual performance is subject to the OMRON Warranty and Limitations of Liability.

PROGRAMMABLE PRODUCTS

OMRON shall not be responsible for the user's programming of a programmable product, or any consequence thereof.

COPYRIGHT AND COPY PERMISSION

This catalog shall not be copied for sales or promotions without permission.

This catalog is protected by copyright and is intended solely for use in conjunction with the product. Please notify us before copying or reproducing this catalog in any manner, for any other purpose. If copying or transmitting this catalog to another, please copy or transmit it in its entirety.