

## Explanation of Terms

### Resolution

The pulse count of an incremental signal output when the shaft revolves once, or the absolute address count.

### Output Phase

The output signal count for an Incremental Encoder. There are 1-phase models (phase A), 2-phase models (phase A, phase B), and 3-phase models (phase A, phase B, and phase Z). The phase Z is an origin signal that is output once a revolution.

### Output Phase Difference

When the shaft is rotated, this is the time difference between the rise or fall of the phase A and phase B signals, expressed as a proportion of the period of one signal, or as an electrical angle where one signal period equals 360°.

The difference between phase A and phase B as an electrical angle is normally 90°.

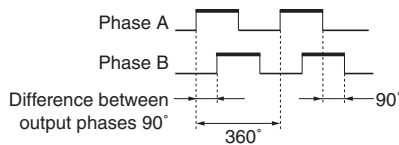

### CW

The clockwise direction of rotation. Viewed from the end of the shaft, the shaft rotates clockwise. With an Incremental Encoder, phase A normally leads phase B in this rotation direction. With an Absolute Encoder, this is the direction of code increase.

The reverse of CW rotation is counterclockwise (CCW) rotation.

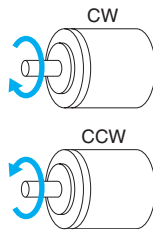

### Output Duty Ratio

This is the ratio of the duration of high level during one period to the average period of pulse output when the shaft is rotated at a constant speed.

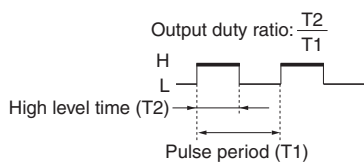

### Maximum Response Frequency

The maximum frequency at which the signal can respond.

### Rise and Fall Times of Output

The elapsed time from a 10% to 90% change in the output pulse.

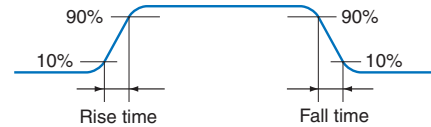

### Output Circuit

#### (1) Open-collector Output

An output circuit where the emitter of the output circuit transistor is the common and the collector is open.

#### (2) Voltage Output

An output circuit where the emitter of the output circuit transistor is the common and a resistor is inserted between the collector and the power supply to convert the output from the collector to a voltage.

#### (3) Line-driver Output

An output method that uses a special IC for high-speed, long-distance data transmission that complies with the RS-422A standard. The signal is output as a differential secondary signal, and thus is strong with respect to noise.

A special IC called a line receiver is used to receive the signal output from a line driver.

#### (4) Complementary Output

An output circuit with two output transistors (NPN and PNP) on the output.

These two output transistors alternately turn ON and OFF depending on the high or low output signal. When using them, pull up to the positive power supply voltage level or pull down to 0 V. The complementary output allows flow-in or flow-out of the output current and thus the rising and falling speeds of signals are fast. This allows a long cable distance.

They can be connected to open-collector input devices (NPN, PNP).

### Starting Torque

The torque needed to rotate the shaft of the Rotary Encoder at startup.

The torque during normal rotation is normally lower than the starting torque. A shaft that has a waterproof seal has a higher starting torque.

## Moment of Inertia

This expresses the magnitude of inertia when starting and stopping the Rotary Encoder.

## Shaft Capacity

This is the load that can be applied to the shaft. The radial load is the load that is perpendicular to the shaft, and the thrust load is the load in the direction along the shaft. Both are permitted on the shaft during rotation, and the size of the load affects the life of the bearings.

## Ambient Operating Temperature

The ambient temperature that meets the specifications, consisting of the permitted values for the external air temperature and the temperature of the parts that contact the Rotary Encoder.

## Ambient Storage Temperature

The ambient temperature when the power is OFF that does not cause functional deterioration, consisting of the permitted values for the external air temperature and the temperature of the parts that contact the Rotary Encoder.

## Degree of Protection

The level of protection against penetration of foreign objects from outside the Rotary Encoder. This is defined in the IEC60529 standard and expressed as IPXX.

The degree of protection against oil is specified by OMRON standards, and is expressed as oil-proof construction or oil resistance.

## Absolute Code

- (1) Binary Code  
A pure binary code, expressed in the format  $2^n$ . Multiple bits may change when an address changes.
- (2) Gray Code  
A code in which only one bit changes when an address changes. The code plate of the Rotary Encoder uses gray code.
- (3) Remainder Gray Code  
This code is used when expressing resolutions with gray code that are not  $2^n$ , such as 36, 360, and 720. The nature of gray code is such that when the most significant bit of the code changes from 0 to 1 and the same size of area is used for both the larger value and the smaller value of objects, the signal only changes by 1 bit within this range when changing from the end to the beginning of a code. This enables any resolution that is an even number to be set with gray code. In this case, the code does not begin from 0, but from an intermediate code, and thus when actually using a code it must first be shifted so that it starts from 0.  
The example in the code table shows 36 divisions. For the change from address 31 to 32, the code extends from address 14 to 49 when 18 addresses each are taken for the objects. When changing from address 49 to 14, only one bit changes, and we can see that the characteristic of gray code is preserved. By shifting the code 14 addresses, it can be converted to a code that starts from address 0.
- (4) BCD  
Binary Coded Decimal Code.  
Each digit of a decimal number is expressed using a binary value.

## Serial Transmission

In contrast to parallel transmission where multiple bits of data are simultaneously output, this method outputs data serially on a single transmission line, enabling the use of fewer wires. The receiving device converts the signals into parallel signals.

## Hollow Shaft

The rotating shaft is hollow, and the drive shaft can be directly connected to the hole in the hollow shaft to reduce the length along the direction of the shaft. A leaf spring is used as a buffer to absorb vibration from the drive shaft.

## Metal Disk

The rotating slit disk in the Encoder is made of metal for higher shock tolerance than glass. Due to slit machining limitations, the metal disk cannot be used for high-resolution applications.

## Servo Mount

A method of mounting the Encoder in which a Servo Mounting Bracket is used to clamp down the flange of the Encoder. The position of the Encoder in the direction of rotation can be adjusted, and thus this method is used to temporarily mount the Encoder to adjust the origin. Refer to *Accessories*.

## Absolute Code Table

Dec- imal	Binary	Gray	Gray re- mainder 14	BCD	
				10	1
0	0 0 0 0 0 0	0 0 0 0 0 0		0 0 0	0 0 0 0
1	0 0 0 0 0 1	0 0 0 0 0 1		0 0 0	0 0 0 1
2	0 0 0 0 1 0	0 0 0 0 0 1		0 0 0	0 0 1 0
3	0 0 0 0 1 1	0 0 0 0 0 1		0 0 0	0 0 1 1
4	0 0 0 1 0 0	0 0 0 0 1 1		0 0 0	0 1 0 0
5	0 0 0 1 0 1	0 0 0 0 1 1		0 0 0	0 1 0 1
6	0 0 0 1 1 0	0 0 0 0 1 0		0 0 0	0 1 1 0
7	0 0 0 1 1 1	0 0 0 0 1 0		0 0 0	0 1 1 1
8	0 1 0 0 0 0	0 0 1 1 0 0		0 0 0	1 0 0 0
9	0 1 0 0 0 1	0 0 1 1 0 1		0 0 0	1 0 0 1
10	0 1 0 0 1 0	0 0 1 1 1 1		0 0 1	0 0 0 0
11	0 1 0 0 1 1	0 0 1 1 1 0		0 0 1	0 0 0 1
12	0 1 1 0 0 0	0 0 1 0 1 0		0 0 1	0 0 1 0
13	0 1 1 0 0 1	0 0 1 0 1 1		0 0 1	0 0 1 1
14	0 1 1 1 0 0	0 0 1 0 0 1	0 0	0 0 1	0 1 0 0
15	0 1 1 1 0 1	0 0 1 0 0 0	0 1	0 0 1	0 1 0 1
16	1 0 0 0 0 0	0 1 1 0 0 0	0 2	0 0 1	0 1 1 0
17	1 0 0 0 0 1	0 1 1 0 0 1	0 3	0 0 1	0 1 1 1
18	0 1 0 0 0 1	0 1 1 0 0 1	0 4	0 0 1	1 0 0 0
19	0 1 0 0 1 0	0 1 1 0 1 0	0 5	0 0 1	1 0 0 1
20	0 1 0 0 1 1	0 1 1 0 1 1	0 6	0 1 0	0 0 0 0
21	0 1 0 1 0 0	0 1 1 1 0 0	0 7	0 1 0	0 0 0 1
22	0 1 0 1 0 1	0 1 1 1 0 1	0 8	0 1 0	0 0 1 0
23	0 1 0 1 1 0	0 1 1 1 0 0	0 9	0 1 0	0 0 1 1
24	0 1 1 0 0 0	0 1 0 1 0 0	1 0	0 1 0	0 1 0 0
25	0 1 1 0 0 1	0 1 0 1 0 1	1 1	0 1 0	0 1 0 1
26	0 1 1 0 1 0	0 1 0 1 1 0	1 2	0 1 0	0 1 1 0
27	0 1 1 0 1 1	0 1 0 1 1 1	1 3	0 1 0	0 1 1 1
28	0 1 1 1 0 0	0 1 0 0 1 0	1 4	0 1 0	1 0 0 0
29	0 1 1 1 0 1	0 1 0 0 1 1	1 5	0 1 0	1 0 0 1
30	0 1 1 1 1 0	0 1 0 0 0 0	1 6	0 1 1	0 0 0 0
31	0 1 1 1 1 1	0 1 0 0 0 1	1 7	0 1 1	0 0 0 1
32	1 0 0 0 0 0	1 1 0 0 0 0	1 8	0 1 1	0 0 1 0
33	1 0 0 0 0 1	1 1 0 0 0 1	1 9	0 1 1	0 0 1 1
34	1 0 0 0 1 0	1 1 0 0 0 1	2 0	0 1 1	0 1 0 0
35	1 0 0 0 1 1	1 1 0 0 0 1	2 1	0 1 1	0 1 0 1
36	1 0 0 1 0 0	1 1 0 0 1 0	2 2	0 1 1	0 1 1 0
37	1 0 0 1 0 1	1 1 0 0 1 1	2 3	0 1 1	0 1 1 1
38	1 0 0 1 1 0	1 1 0 0 1 0	2 4	0 1 1	1 0 0 0
39	1 0 0 1 1 1	1 1 0 0 1 0	2 5	0 1 1	1 0 0 1
40	1 0 1 0 0 0	1 1 1 1 0 0	2 6	1 0 0	0 0 0 0
41	1 0 1 0 0 1	1 1 1 1 0 1	2 7	1 0 0	0 0 0 1
42	1 0 1 0 1 0	1 1 1 1 1 1	2 8	1 0 0	0 0 1 0
43	1 0 1 0 1 1	1 1 1 1 1 0	2 9	1 0 0	0 0 1 1
44	1 0 1 1 0 0	1 1 1 0 1 0	3 0	1 0 0	0 1 0 0
45	1 0 1 1 0 1	1 1 1 0 1 1	3 1	1 0 0	0 1 0 1
46	1 0 1 1 1 0	1 1 1 0 0 0	3 2	1 0 0	0 1 1 0
47	1 0 1 1 1 1	1 1 1 0 0 1	3 3	1 0 0	0 1 1 1
48	1 1 0 0 0 0	1 0 1 0 0 0	3 4	1 0 0	1 0 0 0
49	1 1 0 0 0 1	1 0 1 0 0 1	3 5	1 0 0	1 0 0 1
50	1 1 0 0 1 0	1 0 1 0 0 1		1 0 1	0 0 0 0
51	1 1 0 0 1 1	1 0 1 0 0 1		1 0 1	0 0 0 1
52	1 1 0 1 0 0	1 0 1 1 1 0		1 0 1	0 0 1 0
53	1 1 0 1 0 1	1 0 1 1 1 1		1 0 1	0 0 1 1
54	1 1 0 1 1 0	1 0 1 1 0 1		1 0 1	0 0 1 0
55	1 1 0 1 1 1	1 0 1 1 0 0		1 0 1	0 0 1 1
56	1 1 1 0 0 0	1 0 0 0 1 0		1 0 1	0 1 1 0
57	1 1 1 0 0 1	1 0 0 0 1 0		1 0 1	0 1 1 1
58	1 1 1 0 1 0	1 0 0 0 1 1		1 0 1	1 0 0 0
59	1 1 1 0 1 1	1 0 0 0 1 1		1 0 1	1 0 0 1
60	1 1 1 1 0 0	1 0 0 0 0 1		1 1 0	0 0 0 0
61	1 1 1 1 0 1	1 0 0 0 0 1		1 1 0	0 0 0 1
62	1 1 1 1 1 0	1 0 0 0 0 1		1 1 0	0 0 1 0
63	1 1 1 1 1 1	1 0 0 0 0 0		1 1 0	0 0 1 1

## Interpreting Engineering Data

Bearing Life	Cable Extension Characteristics
<p>E6B2-C</p> <p>Life (<math>\times 10^6</math> rotations)</p> <p>Radial load <math>W_r</math> (N)</p> <p>Encoder</p> <p>Shaft</p> <p><math>W_r</math>: Radial load</p> <p><math>W_s</math>: Thrust load</p> <p><math>W_s</math>: 25N</p> <p><math>W_s</math>: 20N</p> <p><math>W_s</math>: 30N</p> <p><math>W_s</math>: 40N</p>	<p>E6B2-CWZ6C</p> <p>Output rise time <math>t_{LH}</math> (<math>\mu</math>s)</p> <p>Output residual voltage Vol. (V)</p> <p>Cable length (m)</p> <p>VOL</p> <p><math>t_{LH}</math></p> <p>Measurement Example                      Power supply voltage: 5 VDC                      Load resistance: 1 k<math>\Omega</math> (Output residual voltage is measured at a 35 mA load current.)                      Cable: Special Cable</p>
<ul style="list-style-type: none"> <li>This graph shows the relationship between mechanical life and the load applied to the shaft.</li> <li>The size of the load during rotation affects the life of the bearings.</li> </ul>	<ul style="list-style-type: none"> <li>This graph shows the effect of the output waveform if the cable is extended.</li> <li>Extending the cable length not only changes the startup time, but also increases the output residual voltage.</li> </ul>

## Operating Procedure and Data

### Peripheral Device Connectability Yes: Connection possible. No: Connection not possible.

#### Incremental Encoders

Peripheral device		Digital Counter	Self-powered Tachometer	Frequency/Rate Meter	Up/Down Counting Meter	Period Meter	Direction Detection Unit	SYSMAC Pulse I/O Module *	High-speed Counter Unit	EtherCAT-compatible Encoder Input Terminal
Rotary Encoder model	Model	H7BX-A H7CX-A□-N	H7BX-AW H7CX-R□-N H7ER-N	K3HB-R	K3HB-C	K3HB-P	E63-WF5C	CJ2M-CPU1□/ CPU3□ + CJ2M-MD21□	C□-CT□	GX-EC02□□
E6D-CWZ1E		No	No	No	No	No	No	No	Yes	No
E6J-CWZ1E		No	No	No	No	No	No	No	Yes	No
E6D-CWZ2C		Yes	Yes	Yes	Yes	Yes	Yes	No	Yes	No
E6F-CWZ5G		Yes	Yes	Yes	Yes	Yes	Yes	Yes	Yes	Yes
E6A2-CS3E E6A2-CW3E E6A2-CWZ3E E6B2-CWZ3E E6H-CWZ3E E6C2-CWZ3E E6C3-CWZ3EH		Yes	Yes	Yes	Yes	Yes	Yes	No	Yes	No
E6A2-CS3C E6A2-CW3C E6A2-CWZ3C E6A2-CS5C E6A2-CW5C E6B2-CWZ6C E6H-CWZ6C E6C2-CWZ6C E6C3-CWZ5GH		Yes	Yes	Yes	Yes	Yes	Yes	Yes	Yes	Yes
E6B2-CWZ1X E6H-CWZ3X E6C2-CWZ1X E6C3-CWZ3XH		No	No	No	No	No	No	Yes	Yes	Yes
E6B2-CWZ5B E6C2-CWZ5B		No	No	Yes	No	Yes	No	No	No	No

\* Supported by CJ2M CPU Unit with unit version 2.0 or later.

## Absolute Encoders

Peripheral device		Cam Positioner	SYSMAC Programmable Controller						
Rotary Encoder model	Model		H8PS	CPM1A	CP1H	CP1L	CP1E	DC Input Unit	
E6CP-AG5C		No	Yes	Requires separate power supply for Encoder.	Yes	Yes	Yes	Yes	Requires separate power supply for Encoder.
E6C3-AG5C									
E6CP-AG5C-C		Yes	No		No	No	No	No	
E6C3-AG5C-C									
E6F-AG5C-C									
E6F-AB3C		No	Yes	Requires separate power supply for Encoder.	Yes	Yes	Yes	Yes	Requires separate power supply for Encoder.
E6F-AB3C-C		No	No		No	No	No	No	

### Example of Connection with H7BX-AW Self-powered Tachometer

<b>Example of Applicable Models</b>	E6A2-CS3E 10P/R, 60P/R E6C2-CWZ3E, E6F-CWZ5G 600P/R E6C3-CWZ3EH 10P/R, 60P/R, 600P/R
-------------------------------------	--

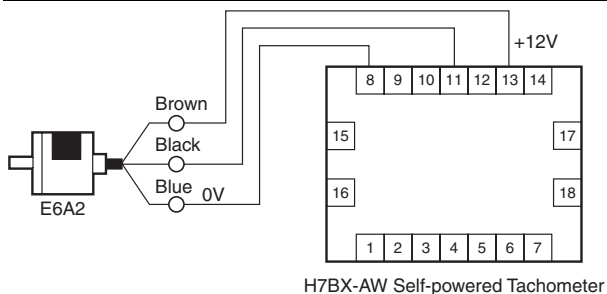

### Example of Connection with H7BX-A Digital Counter

<b>Example of Applicable Models</b>	E6A2-CW3E E6C2-CWZ3E, E6C3-CWZ3EH, E6F-CWZ5G
-------------------------------------	--

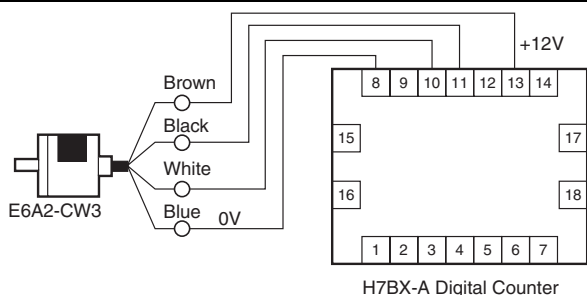

### Example of Connection with K3HB-C Up/Down Counting Meter

- NPN Open-collector Outputs

<b>Example of Applicable Models</b>	E6A2-CS3C, E6A2-CS5C E6A2-CW3C, E6A2-CW5C E6C2-CWZ6C, E6F-CWZ5G
-------------------------------------	---

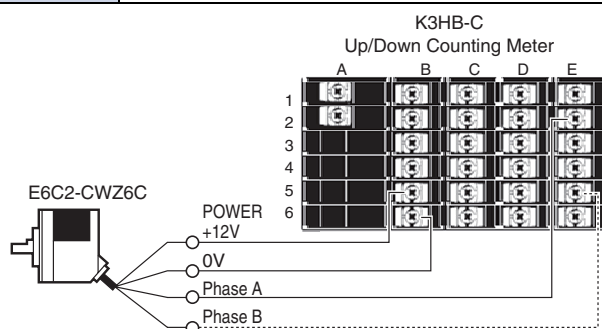

- Voltage Outputs

<b>Example of Applicable Models</b>	E6A2-CS3E, E6A2-CW3E E6C2-CWZ3E
-------------------------------------	------------------------------------

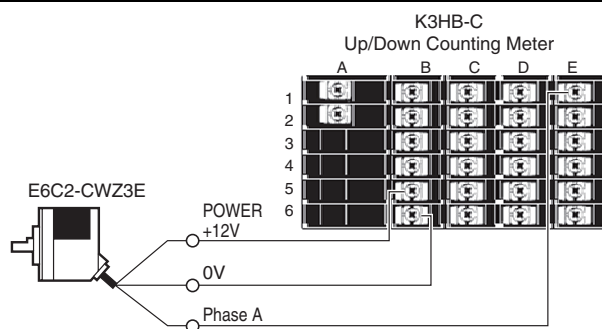

# Rotary Encoders Technical Guide

## Example of Connection with CJ1W-CT021 High-speed Counter Unit in Programmable Controller

**Example of Applicable Models (1)** E6A2-C, E6B2-C, E6C2-C, E6H-C  
E6F-CWZ5G,  
E6D (open-collector output)

Encoder with NPN Open-collector Output (5/12/24 VDC)

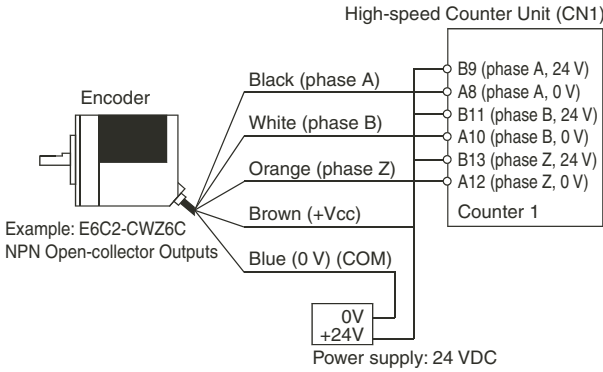

Note: Connections are as follows if the Encoder power supply is 5 V or 24 V.  
Phase A + 5-V power supply → A19, 24 V → B20  
Phase B + 5-V power supply → A17, 24 V → B18

**Example of Applicable Models (2)** E6B2-CWZ5B  
E6C2-CWZ5B, E6C3-CWZ5GH

Encoder with PNP Open-collector Output (5/12/24 VDC)

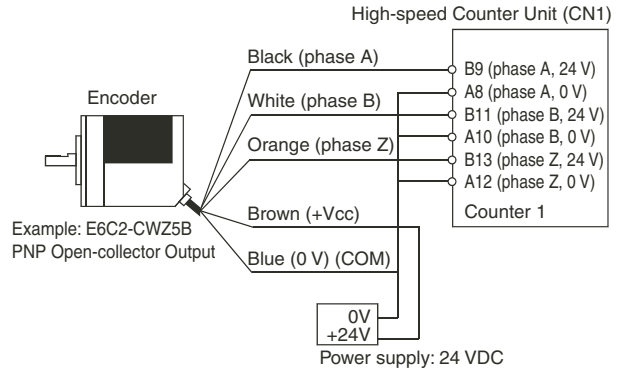

Note: Note: Connections are as follows if the Encoder power supply is 5 V or 24 V.  
Phase A + 5-V power supply → A19, 24 V → B20  
Phase B + 5-V power supply → A17, 24 V → B18

**Example of Applicable Models (3)** E6B2-CWZ1X, E6C2-CWZ1X  
E6C3-CWZ3XH, E6H-CWZ3X

Encoder with Line-driver Output (RS-422)

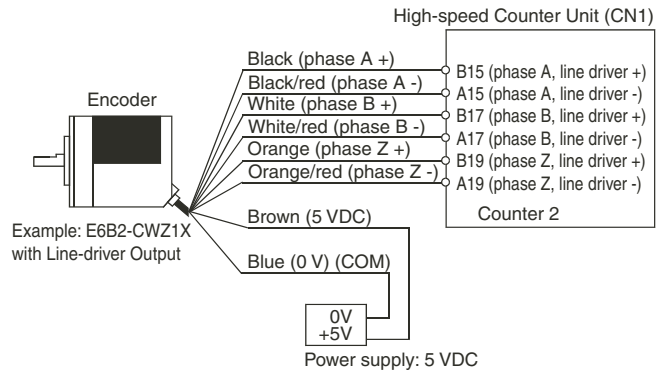

## Example of Connection with CJ2M-CPU1□/CPU3□ + CJ2M-MD21□ SYSMAC Pulse I/O Module

<b>Example of Applicable Models</b>	E6A2-CWZ5C, E6C2-CWZ6C, E6C3-CWZ5GH, E6F-CWZ5G
-------------------------------------	--

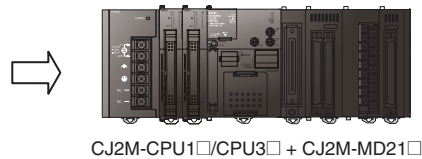
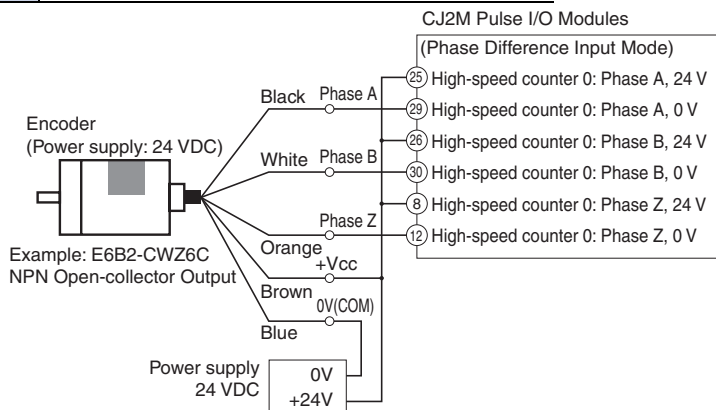

CJ2M-CPU1□/CPU3□ + CJ2M-MD21□

- Up to two Pulse I/O Modules can be mounted to a CJ2M CPU Unit with unit version 2.0 or later. Each Pulse I/O Module allows you to use six inputs (IN8, IN9, IN3, IN6, IN7, and IN2) to directly input pulses from rotary encoders for application in built-in high-speed counters.
- The response speed is 60 kHz for single phase and the phase difference (multiplier of 4) is 30 kHz. Counting can be performed from 0 to 4,294,967,295 pulses in incremental mode and from -2,147,483,648 to 2,147,483,647 in incremental/decremental mode.
- Operating modes for the high-speed counter are set in the PLC Setup.

### <Count Mode>

<b>Phase difference input mode</b>	Incremental/decremental counting is performed using the phase difference between phases A and B (4-times multiplier constant).
<b>Increment/decrement pulse input mode</b>	Incremental/decremental counting is performed using phase A as the incremental pulse input and phase B as the decremental pulse input.
<b>Pulse and direction input mode</b>	Incremental/decremental counting is performed using phase A as the pulse input and phase B as the direction signal (i.e., incremental/decremental).
<b>Incremental pulse input mode</b>	Incremental counting is performed using phase A only.

### <Value range mode>

<b>Linear mode</b>	Counting is performed within the range of the upper limit and lower limit.
<b>Ring mode</b>	Counting is performed by looping the input pulse within the set range.

### <Reset Method>

<b>Phase Z and software reset</b>	If software reset is ON, the present value will be reset when the phase-Z input turns ON.
<b>Software reset</b>	The present value will be reset when software reset turns ON.

### <Output Method>

<b>Target value comparison</b>	Up to 48 target values can be set. When the present value reaches a target value, the specified subroutine is executed.
<b>Range comparison</b>	Up to 8 ranges (upper and lower limits) can be set. When the present value enters a range, the specified subroutine is executed.

<b>Example of Applicable Models</b>	E6B2-CWZ1X, E6C2-CWZ1X, E6C3-CWZ3XH, E6H-CWZ3X with Line-driver Output
-------------------------------------	--

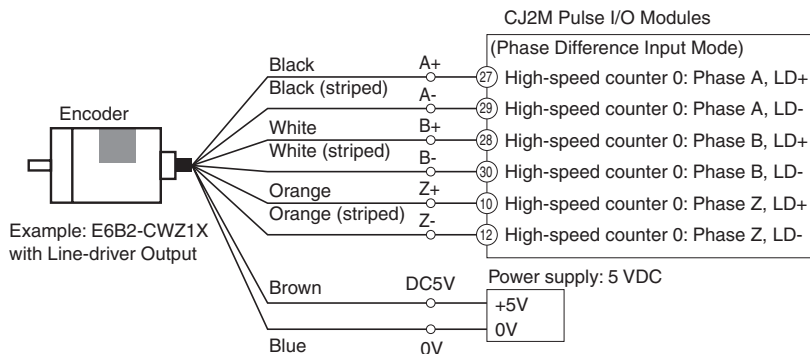

CJ2M-CPU1□/CPU3□ + CJ2M-MD21□