

# Stepping Relay Unit G9B

CSM\_G9B\_DS\_E\_3\_1

## Ideal for Controlling Pumps and Production Lines with Six or Twelve Stepping Circuits

- Built-in relays switch 2 A at 250 VAC or 30 VDC.
- Initialization of stepping with reset input.
- Uses memory that stores setting status for 10 days without power. All internal contacts are released when no power is supplied.
- Detects an internal element malfunction caused by external noise, indicates the malfunction with an alarm indicator, and turns the relay alarm output ON. (An internal relay malfunction or internal relay contact weld cannot be detected.)
- With safety-design terminals which prevent electric shock accidents.
- With easy-to-see indicators which display the stepping status.



Refer to *Safety Precautions for All Relays*.

## Ordering Information

No. of steps	Model	Rated voltage
6	G9B-06	24 VDC
		100 VAC
		200 VAC
12	G9B-12	24 VDC
		100 VAC
		200 VAC

**Note:** When ordering specify the voltage.

Example: G9B-06 24 VDC  
\_\_\_\_\_ Rated voltage

## Model Number Legend

G9B-□  
 1

### 1. No. of steps

- 06: 6 steps
- 12: 12 steps

# Specifications

## ■ Contact Ratings

Load	Resistive load ( $\cos\phi = 1$ )
Rated load	2 A at 250 VAC/30 VDC
Rated carry current	2 A
Max. switching voltage	250 VAC, 30 VDC
Max. switching current	2 A

## ■ Characteristics

Operating voltage range	85% to 110% of rated voltage
Power consumption	24 VDC:90 mA max. 100 or 200 VAC:120 mA max.
Contact resistance (See note 2.)	100 m $\Omega$ max.
Operate time (See note 3.)	50 ms max.
Release time (See note 3.)	50 ms max.
Min. pulse time (See note 4.)	100 ms max.
Error detecting time	100 ms max.
Insulation resistance (at 500 VDC)	100 M $\Omega$ min. between the power supply, control, output, and R terminals 100 M $\Omega$ min. between the terminals, except the alarm output terminals and power output terminals
Dielectric strength	1,500 V, 50/60 Hz for 1 min between the power supply, control, output, and R and other terminals 1,500 V, 50/60 Hz for 1 min between the terminals, except the alarm output terminals and power output terminals
Noise immunity	Noise level: 1.5 kV, pulse width: 50 ns/1 $\mu$ s (600 V for 24-VDC model)
Vibration resistance	Destruction: 10 to 55 to 10 Hz, 0.75-mm single amplitude (1.5 mm double amplitude) Malfunction: 10 to 55 to 10 Hz, 0.75-mm single amplitude (1.5 mm double amplitude)
Shock resistance	Destruction: 500 m/s <sup>2</sup> Malfunction: 200 m/s <sup>2</sup>
Endurance	Mechanical: 10,000,000 steps min. Electrical: 300,000 steps min. (See note 5.)
Error rate (See note 6.)	10 mA at 5 VDC
Ambient temperature	Operating: -25°C to 55°C (with no icing or condensation)
Ambient humidity	Operating: 5% to 85%
Terminal strength	Tightening torque: 0.98 N·m Tensile strength: 49 N
Weight	Twelve-step model: approx. 450 g; Six-step model: approx. 400 g

**Note:** 1. The data shown above are initial values.

2. The contact resistance was measured with 0.1 A at 5 VDC using the fall-of-potential method.
3. The operate time and release time was measured with the rated voltage imposed with any contact bounce ignored at an ambient temperature of 23°C.
4. For the step signal, set a minimum pulse time of 100 ms for both the ON time and OFF time.
5. The electrical endurance was measured at an ambient temperature of 23°C.
6. This value was measured at a switching frequency of 120 operations per minute.

# Nomenclature

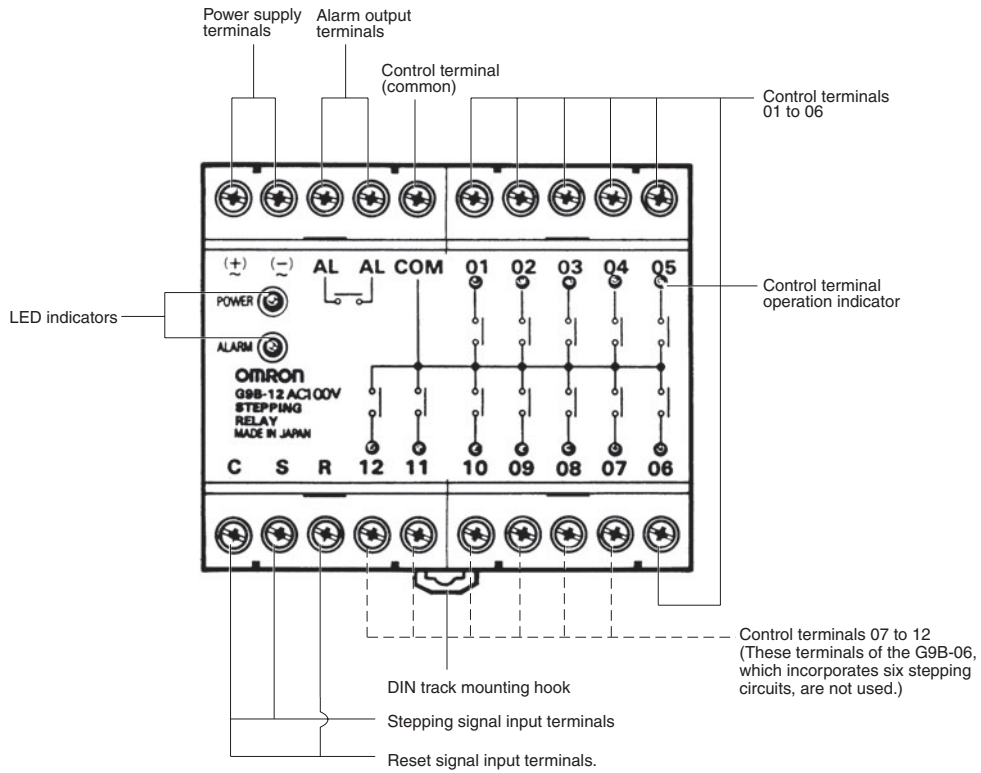

Display		Description
POWER	Lit	Lit when power is supplied to the G9B and the G9B is ready to operate or in operation.
	Not lit	Not lit when power is not supplied to the G9B.
ALARM	Lit	Lit when there is a control contact error (i.e., when a built-in relay driving element is malfunctioning).
	Not lit	Lit when the G9B is in normal operation.

# Operation

## ■ Timing Chart

### Normal Operation with No Reset Signal

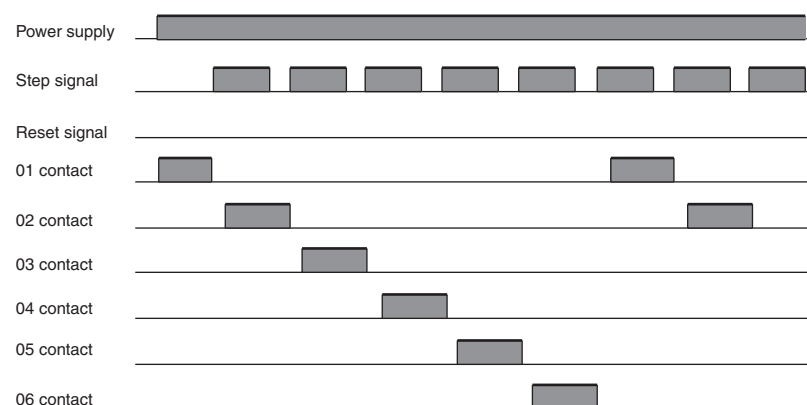

A different contact is selected in numerical order per step signal pulse. When the contact currently selected is 06, 01 will be selected with the next step signal input.

### Normal Operation with Reset Signal

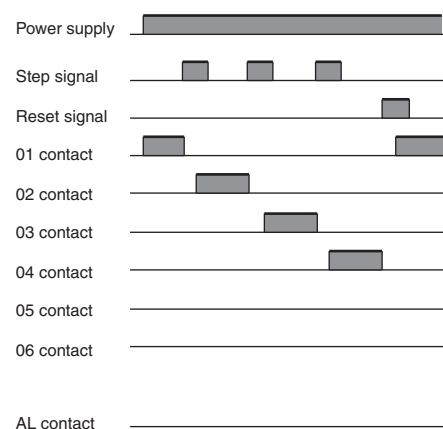

The G9B switches an active control terminal over to another control terminal and makes it active whenever the G9B receives a single step input pulse. If a reset signal is input to a control terminal of the G9B when the G9B is in stepping operation, terminal 1 of the G9B will become active.

### Emergency Case (ON Error)

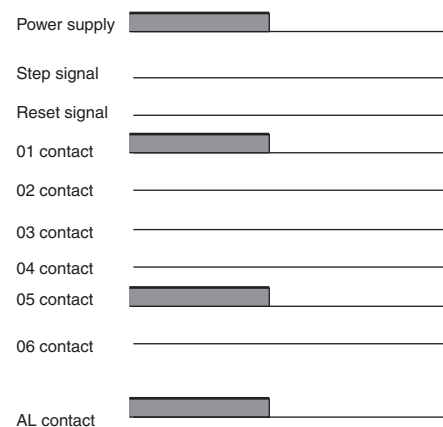

If an internal contact of the G9B is incorrectly turned ON by the internal relay driving element that drives the internal contact due to external noise, the G9B will reset itself to its default status (i.e., contact 01 of the G9B will be turned ON) and turn its alarm contact ON so that the ALARM indicator of the G9B will become lit. When the G9B is turned OFF, the alarm contact will turn OFF and the ALARM indicator will not be lit. In this example, contact 05 is incorrectly turned ON.

**Emergency Case (ON Error)**

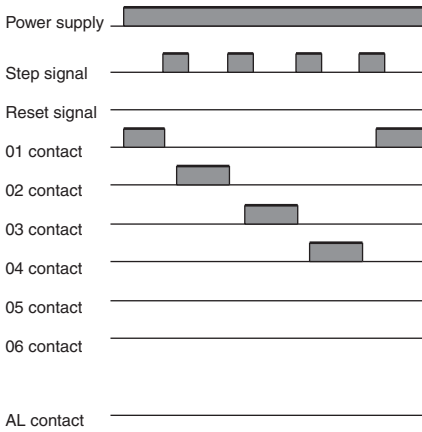

If an internal contact of the G9B is incorrectly turned OFF by the internal relay driving element that drives the internal contact due to external noise, the G9B will reset itself to its default status (i.e., contact 01 of the G9B will be turned ON) when the internal contact incorrectly turned OFF becomes active. In this example, contact 05 is incorrectly turned OFF.

# Dimensions

**Note:** All units are in millimeters unless otherwise indicated.

**G9B-06**

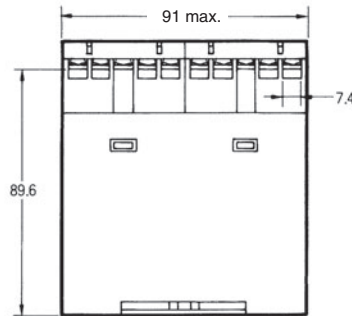
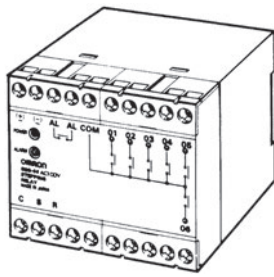

**G9B-12**

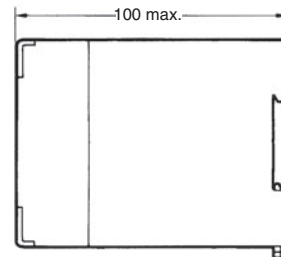
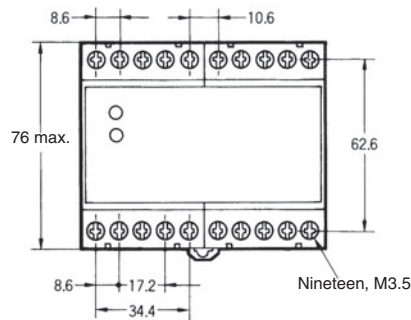
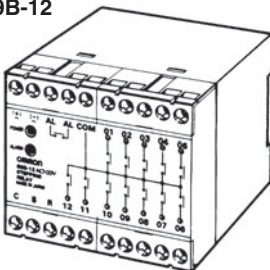

# Installation

## Internal Circuit

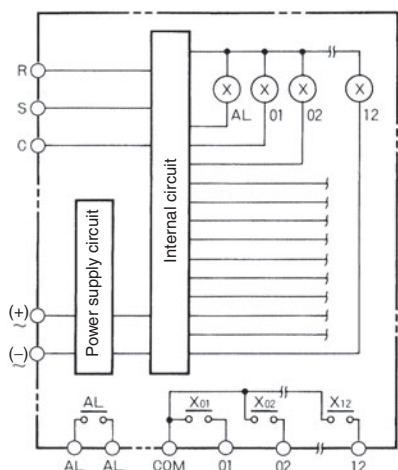

## Input Connections

The inputs of the G9B are no-voltage (short-circuited or open) inputs.

### No-contact Input

(Connection to NPN open collector output sensor.)

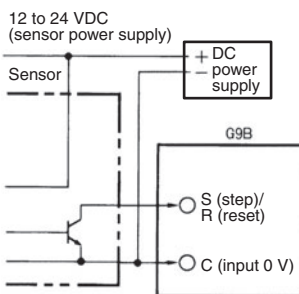

Operates with transistor ON

### Contact Input

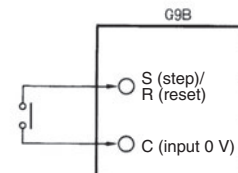

Operates with relay ON

## Terminal Arrangement

G9B-06

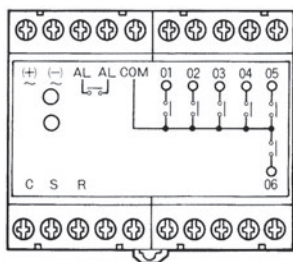

G9B-12

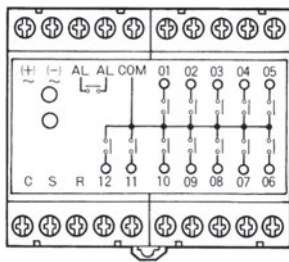

## No-voltage Input Signal Level

No-contact input	<ol style="list-style-type: none"> <li>Short-circuit Level (transistor ON) Residual voltage: 1 V max. Impedance when ON: 1 kΩ max.</li> <li>Open Level (transistor OFF) Impedance when OFF: 100 kΩ max.</li> </ol>
Contact input	Use contacts which can adequately switch 3 mA at 24 VDC

- Note:**
- Two-wire sensors cannot be used.
  - When using three-wire sensors, only NPN open-collector models can be used.

# Safety Precautions

Refer to *Safety Precautions for All Relays*.

## Memory Backup Function

The G9B has a built-in memory that stores the setting status for 10 days without power. All contacts are released when no power is supplied. When the G9B is turned ON again, the internal contacts will be set to the previous setting status.

When power is not supplied, the output contacts will turn OFF. If a reset signal is input while power is not being supplied, the next step will be step 01 when power is restored.

When 24 VDC is supplied to the G9B, make sure that the polarity of the power is correct.

ALL DIMENSIONS SHOWN ARE IN MILLIMETERS.  
To convert millimeters into inches, multiply by 0.03937. To convert grams into ounces, multiply by 0.03527.

In the interest of product improvement, specifications are subject to change without notice.

## Read and Understand This Catalog

Please read and understand this catalog before purchasing the products. Please consult your OMRON representative if you have any questions or comments.

## Warranty and Limitations of Liability

### WARRANTY

OMRON's exclusive warranty is that the products are free from defects in materials and workmanship for a period of one year (or other period if specified) from date of sale by OMRON.

OMRON MAKES NO WARRANTY OR REPRESENTATION, EXPRESS OR IMPLIED, REGARDING NON-INFRINGEMENT, MERCHANTABILITY, OR FITNESS FOR PARTICULAR PURPOSE OF THE PRODUCTS. ANY BUYER OR USER ACKNOWLEDGES THAT THE BUYER OR USER ALONE HAS DETERMINED THAT THE PRODUCTS WILL SUITABLY MEET THE REQUIREMENTS OF THEIR INTENDED USE. OMRON DISCLAIMS ALL OTHER WARRANTIES, EXPRESS OR IMPLIED.

### LIMITATIONS OF LIABILITY

OMRON SHALL NOT BE RESPONSIBLE FOR SPECIAL, INDIRECT, OR CONSEQUENTIAL DAMAGES, LOSS OF PROFITS OR COMMERCIAL LOSS IN ANY WAY CONNECTED WITH THE PRODUCTS, WHETHER SUCH CLAIM IS BASED ON CONTRACT, WARRANTY, NEGLIGENCE, OR STRICT LIABILITY.

In no event shall the responsibility of OMRON for any act exceed the individual price of the product on which liability is asserted.

IN NO EVENT SHALL OMRON BE RESPONSIBLE FOR WARRANTY, REPAIR, OR OTHER CLAIMS REGARDING THE PRODUCTS UNLESS OMRON'S ANALYSIS CONFIRMS THAT THE PRODUCTS WERE PROPERLY HANDLED, STORED, INSTALLED, AND MAINTAINED AND NOT SUBJECT TO CONTAMINATION, ABUSE, MISUSE, OR INAPPROPRIATE MODIFICATION OR REPAIR.

## Application Considerations

### SUITABILITY FOR USE

OMRON shall not be responsible for conformity with any standards, codes, or regulations that apply to the combination of products in the customer's application or use of the products.

At the customer's request, OMRON will provide applicable third party certification documents identifying ratings and limitations of use that apply to the products. This information by itself is not sufficient for a complete determination of the suitability of the products in combination with the end product, machine, system, or other application or use.

The following are some examples of applications for which particular attention must be given. This is not intended to be an exhaustive list of all possible uses of the products, nor is it intended to imply that the uses listed may be suitable for the products:

- Outdoor use, uses involving potential chemical contamination or electrical interference, or conditions or uses not described in this catalog.
- Nuclear energy control systems, combustion systems, railroad systems, aviation systems, medical equipment, amusement machines, vehicles, safety equipment, and installations subject to separate industry or government regulations.
- Systems, machines, and equipment that could present a risk to life or property.

Please know and observe all prohibitions of use applicable to the products.

NEVER USE THE PRODUCTS FOR AN APPLICATION INVOLVING SERIOUS RISK TO LIFE OR PROPERTY WITHOUT ENSURING THAT THE SYSTEM AS A WHOLE HAS BEEN DESIGNED TO ADDRESS THE RISKS, AND THAT THE OMRON PRODUCTS ARE PROPERLY RATED AND INSTALLED FOR THE INTENDED USE WITHIN THE OVERALL EQUIPMENT OR SYSTEM.

### PROGRAMMABLE PRODUCTS

OMRON shall not be responsible for the user's programming of a programmable product, or any consequence thereof.

## Disclaimers

### CHANGE IN SPECIFICATIONS

Product specifications and accessories may be changed at any time based on improvements and other reasons.

It is our practice to change model numbers when published ratings or features are changed, or when significant construction changes are made. However, some specifications of the products may be changed without any notice. When in doubt, special model numbers may be assigned to fix or establish key specifications for your application on your request. Please consult with your OMRON representative at any time to confirm actual specifications of purchased products.

### DIMENSIONS AND WEIGHTS

Dimensions and weights are nominal and are not to be used for manufacturing purposes, even when tolerances are shown.

### PERFORMANCE DATA

Performance data given in this catalog is provided as a guide for the user in determining suitability and does not constitute a warranty. It may represent the result of OMRON's test conditions, and the users must correlate it to actual application requirements. Actual performance is subject to the OMRON Warranty and Limitations of Liability.

### ERRORS AND OMISSIONS

The information in this document has been carefully checked and is believed to be accurate; however, no responsibility is assumed for clerical, typographical, or proofreading errors, or omissions.

2010.8

In the interest of product improvement, specifications are subject to change without notice.

**OMRON Corporation**  
Industrial Automation Company

<http://www.ia.omron.com/>

(c)Copyright OMRON Corporation 2010 All Right Reserved.