

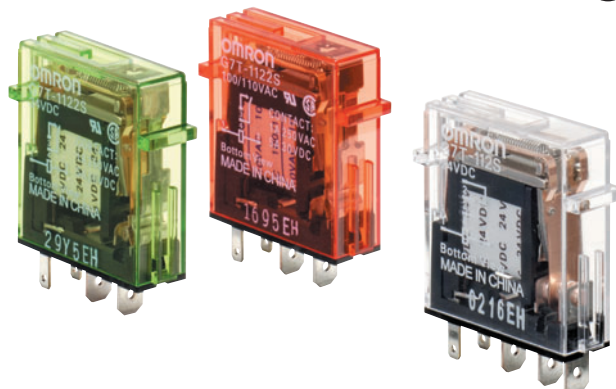

Slim-styled I/O Relay Saves Space in Panel

- SPST-NO, SPST-NC, and SPDT contact forms available for output (SPST-NO only for input).
- Ultra-slim housing measuring 29 (W) x 10 (D) x 32 (H) mm.
- All Output Relays provide a long endurance (1,000,000 operations at 5 A), while all Input Relays provide microswitching power (100 μ A at 1 V).
- Approved by UL and CSA standards.



 Refer to *Safety Precautions for All Relays*.

For the most recent information on models that have been certified for safety standards, refer to your OMRON website.

Ordering Information

Classification		Model	Rated voltage
Input (bifurcated contact)	SPST-NO	G7T-1122S (see note 2)	12 VDC
			24 VDC
			100/110 VAC
			200/220 VAC
Output (single contact)	SPST-NO	G7T-1112S (see note 2)	12 VDC
			24 VDC
	SPST-NC	G7T-1012S	12 VDC
			24 VDC
	SPDT	G7T-112S	12 VDC
			24 VDC

Note: 1. When ordering, add the rated voltage to the model number. Rated voltages are given in the coil ratings table in *Specifications*.
Example: G7T-112S 12 VDC

Rated voltage

- The G7T-1122S and G7T-1112S are approved by UL and CSA. Contact your OMRON representative for the coil ratings of other models. The G7T-1122S cannot be used in place of the G7TC. The G7T-112S can only be used with the P7TF-05 Socket.
- “Input” and “output” indicate the I/O relationship to a PLC. Input Relays are mainly suitable for input signals to a PLC or other device. Output Relays are mainly suitable to switching loads that receive output signals from a PLC or other device. The Input and Output Relays have different switching performances. Select a suitable Relay for the application.

Model Number Legend

G7T-□□□□S
1 2 3 4 5

1. No. of Contact Poles

2. Contact Form

No indication: Transfer contact

Number: Number of NO contacts

3. Contact Mechanism

1: Single contact

2: Bifurcated contact

4. Enclosure Construction

2: Casing

5. Terminal Type

S: Plug-in Terminal

■ Accessories

Socket

Applicable Relay	Model
All G7T I/O Relay and the G3TA models.	P7TF-05

P70 Indicator Module

Remove the transparent style strip of the Socket and mount this module. It will function as an operation indicator with surge suppression.

Model	Applicable Relay coil voltage	Remarks
For AC Relay	P70A	100/110 VAC
		200/220 VAC
For DC Relay	P70D	12/24 VDC

- Note:**
1. Order the Indicator Module that is suited to the Relay coil voltage.
 2. The Indicator Module for DC Relays has a multiple power supply common to 12 and 24 VDC.
 3. Input current (reference values):
 100/110 VAC: 1.14 to 1.38 mA
 200/220 VAC: 1.40 to 1.71 mA
 12/24 VDC: 4.83 to 5.90 mA

Specifications

■ Ratings

Coil Ratings (Common to Both Input and Output)

Rated voltage (V)	Item	Rated current		Coil resistance	Must operate voltage	Must release voltage	Max. voltage	Power consumption
		50 Hz	60 Hz					
AC	100/110	8.2/9 mA	7/7.7 mA	8,700 Ω	80% max. of rated value	30% min. of rated value	110% of rated value	0.7 VA
	200/220	4.1/4.5 mA	3.5/3.85 mA	33,300 Ω				
DC	12	42 mA		290 Ω	80% max. of rated value	10% min. of rated value	110% of rated value	0.5 W
	24	21 mA		1,150 Ω				
	100/110	5 mA		20,000 Ω				

- Note:**
1. The rated current and coil resistance values are measured at a coil temperature of 23°C. Tolerances of AC rated current are +15%, -20% and tolerances of coil resistance are ±15%.
 2. Four rated voltages or currents are available to single AC models used with the P7TF-05 Socket. Only three rated voltages or currents are available, however, when the Relay is used in place of the G7TC.
 3. The operating characteristics values are for a coil temperature of 23°C.
 4. The maximum voltage is one that is applicable to the Relay coil instantaneously at 23°C and not continuously.

Contact Ratings

Item	Classification	For input		For output	
		Resistive load (cosφ = 1)	Inductive load (L/R = 7 ms)	Resistive load (cosφ = 1)	Inductive load (cosφ = 0.4, L/R = 7 ms)
Contact mechanism	Crossbar bifurcated			Single	
Contact material	AgAu-clad Ag			AgSnIn	
Rated load		1 A at 24 VDC	0.5 A at 24 VDC	5 A at 24 VDC 2 A at 220 VAC	2 A at 24 VDC 1 A at 220 VAC
Rated carry current		1 A		5 A	
Max. switching voltage		250 VAC, 125 VDC			
Max. switching current		1 A		5 A	
Failure rate (reference value)		100 μA at 1 VDC		10 mA at 5 VDC	

■ Characteristics

Contact resistance (see note 2)	50 mΩ max.
Operate time (see note 3)	15 ms max.
Release time (see note 3)	15 ms max.
Max. operating frequency	Mechanical: 18,000 operations/hour Electrical: 1,800 operations/hour (under rated load)
Insulation resistance (see note 4)	100 MΩ (at 500 VDC)
Dielectric strength	Between coil and contacts: 2,000 VAC, 50/60 Hz for 1 minute Between contacts of same polarity: 1,000 VAC, 50/60 Hz for 1 minute
Vibration resistance	Malfunction: 10 to 55 to 10 Hz, 0.5 mm single amplitude (1.0 mm double amplitude)
Shock resistance	Malfunction: 200 m/s ²
Mechanical endurance	50,000,000 operations
Electrical endurance (see note 5)	Input: 10,000,000 operations (10 mA) or 50,000 operations (1 A) with resistive load 2,500,000 operations (10 mA) or 20,000 operations (1 A) with inductive load Output: 1,000,000 operations with rated load
Error rate (level P) (Reference value) (see note 6)	Input: 100 μA at 1 VDC Output: 10 mA at 5 VDC
Ambient temperature	Operating: -40°C to 70°C (with no icing or condensation)
Ambient humidity	Operating: 5% to 85% (with no icing or condensation)
Weight	Approx. 17 g

Note: 1. The above values are all initial values.

- The contact resistance was measured with 1 A at 5 VDC using the voltage drop method.
- The operate and the release times were measured with the rated voltage imposed with any contact bounce ignored at an ambient temperature of 23°C.
- The insulation resistance was measured with a 500-VDC megger applied to the same places as those used for checking the dielectric strength.
- The electrical endurance was measured at an ambient temperature of 23°C.
- This value was measured at a switching frequency of 120 operations per minute.

■ Socket Ratings

Features

- Easily mounts or dismounts the G7T I/O Relay.
- Also mounts the Indicator Module (with surge suppressing function).
- Only 19 mm in width.
- Terminals corresponding to the NO and NC contacts of a Relay are arranged on top of the Socket to enhance maintainability.
- Also permits mounting of the G3TA Solid-state I/O Relay.

Specifications

Model	P7TF-05
Contact resistance	10 mΩ max.
Dielectric strength	2,000 VAC for 1 minute
Insulation resistance	1,000 MΩ (at 500 VDC)
Vibration resistance	10 to 55 to 10 Hz, 0.5 mm single amplitude (1.0 mm double amplitude)
Shock resistance	1,000 m/s ²
Ambient temperature	Operating: 0°C to 55°C
Ambient Humidity	Operating: 5% to 85%
Weight	Approx. 28 g

Engineering Data

Maximum Switching Power (Output Model with Life of 1,000,000 Operations)

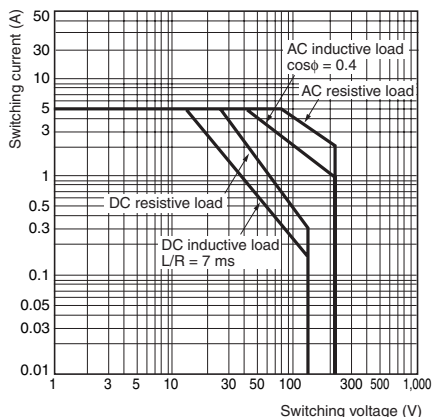

Electrical Endurance Output Relay

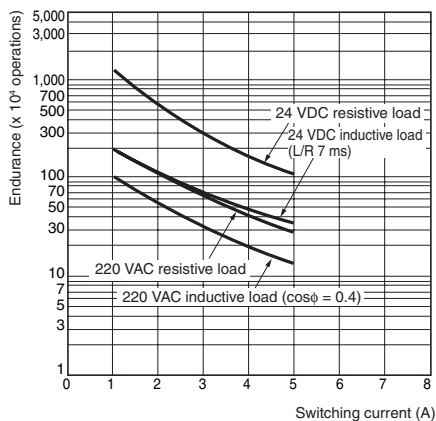

Input Relay

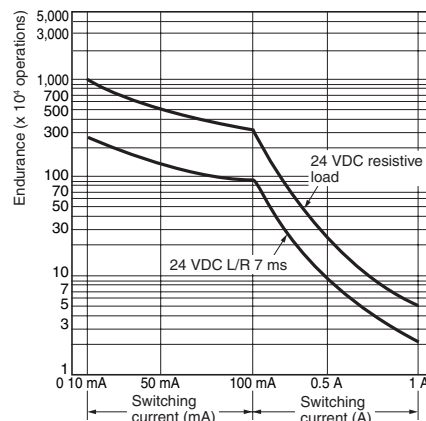

Dimensions

Note: All units are in millimeters unless otherwise indicated.

SPST-NO Type
G7T-1122S (for input)
G7T-1112S (for output)

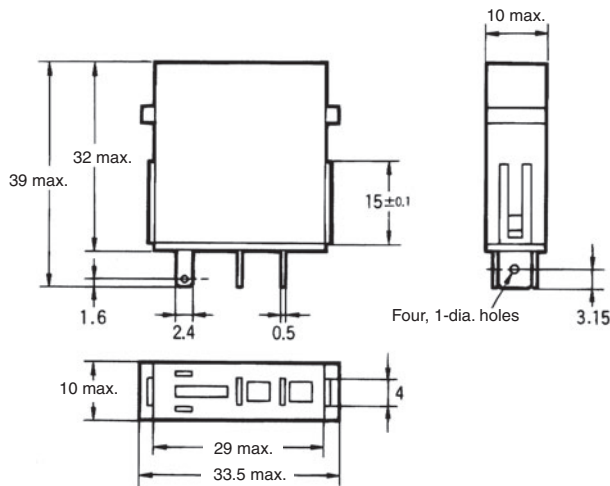
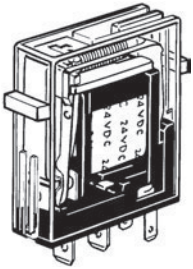

**Terminal Arrangement/
Internal Connections
(Bottom View)**

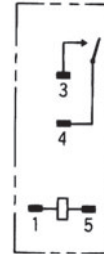

SPST-NC Type
G7T-1012S (for output)

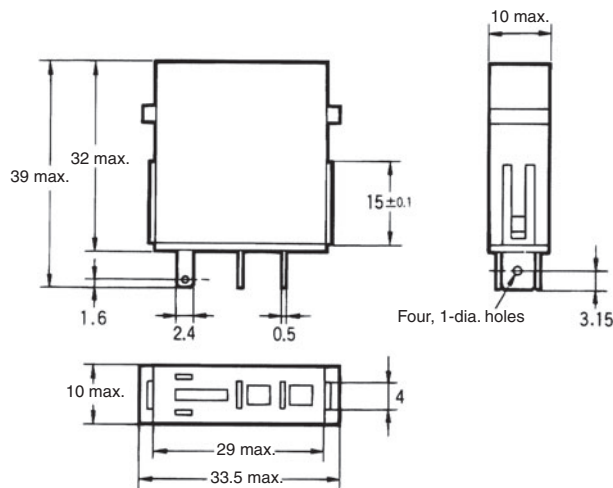
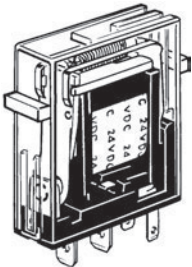

**Terminal Arrangement/
Internal Connections
(Bottom View)**

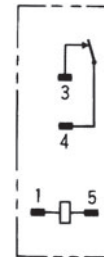

SPDT Type
G7T-112S (for output)

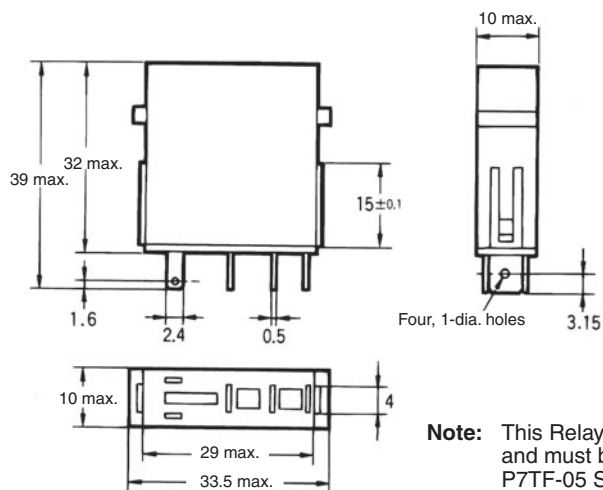
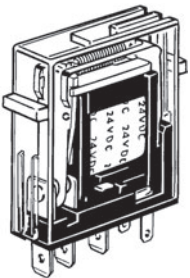

**Terminal Arrangement/
Internal Connections
(Bottom View)**

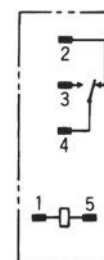

Note: This Relay cannot be used as an I/O relay terminals and must be used in combination with the exclusive P7TF-05 Socket.

■ Accessories

Socket

P7TF-05

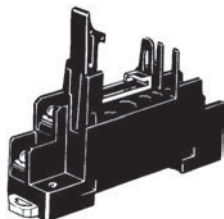

Dimensions

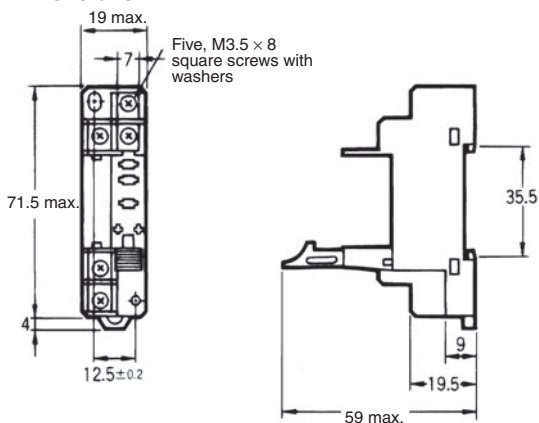

Internal Connections (Top View)

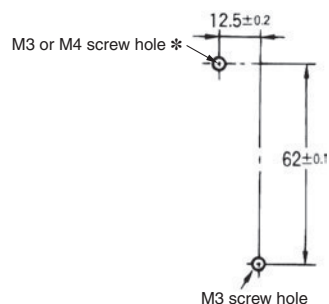
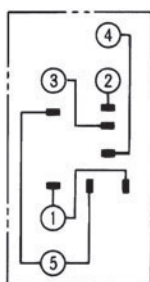

Note: If the I/O SSR or Indicator Module is used, be aware that the polarity of terminal 1 is positive.

* We recommend that you insert washers when mounting with M3 screws. A washers are not required when mounting with M4 screws.

Indicator Module (with Surge Suppressing Function)

P70

Dimensions

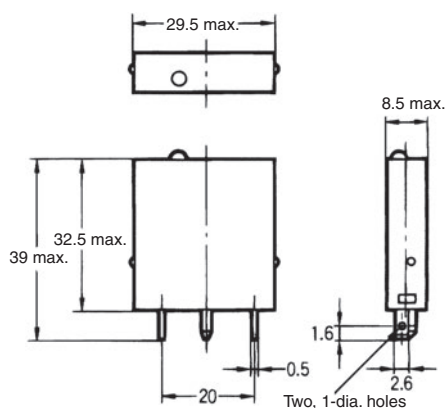
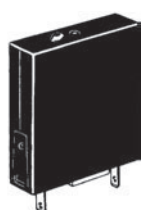

Internal Connections

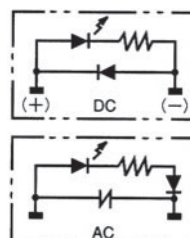

Safety Precautions

Refer to *Safety Precautions for All Relays*.

ALL DIMENSIONS SHOWN ARE IN MILLIMETERS.

To convert millimeters into inches, multiply by 0.03937. To convert grams into ounces, multiply by 0.03527.

In the interest of product improvement, specifications are subject to change without notice.

Read and Understand This Catalog

Please read and understand this catalog before purchasing the products. Please consult your OMRON representative if you have any questions or comments.

Warranty and Limitations of Liability

WARRANTY

OMRON's exclusive warranty is that the products are free from defects in materials and workmanship for a period of one year (or other period if specified) from date of sale by OMRON.

OMRON MAKES NO WARRANTY OR REPRESENTATION, EXPRESS OR IMPLIED, REGARDING NON-INFRINGEMENT, MERCHANTABILITY, OR FITNESS FOR PARTICULAR PURPOSE OF THE PRODUCTS. ANY BUYER OR USER ACKNOWLEDGES THAT THE BUYER OR USER ALONE HAS DETERMINED THAT THE PRODUCTS WILL SUITABLY MEET THE REQUIREMENTS OF THEIR INTENDED USE. OMRON DISCLAIMS ALL OTHER WARRANTIES, EXPRESS OR IMPLIED.

LIMITATIONS OF LIABILITY

OMRON SHALL NOT BE RESPONSIBLE FOR SPECIAL, INDIRECT, OR CONSEQUENTIAL DAMAGES, LOSS OF PROFITS OR COMMERCIAL LOSS IN ANY WAY CONNECTED WITH THE PRODUCTS, WHETHER SUCH CLAIM IS BASED ON CONTRACT, WARRANTY, NEGLIGENCE, OR STRICT LIABILITY.

In no event shall the responsibility of OMRON for any act exceed the individual price of the product on which liability is asserted.

IN NO EVENT SHALL OMRON BE RESPONSIBLE FOR WARRANTY, REPAIR, OR OTHER CLAIMS REGARDING THE PRODUCTS UNLESS OMRON'S ANALYSIS CONFIRMS THAT THE PRODUCTS WERE PROPERLY HANDLED, STORED, INSTALLED, AND MAINTAINED AND NOT SUBJECT TO CONTAMINATION, ABUSE, MISUSE, OR INAPPROPRIATE MODIFICATION OR REPAIR.

Application Considerations

SUITABILITY FOR USE

OMRON shall not be responsible for conformity with any standards, codes, or regulations that apply to the combination of products in the customer's application or use of the products.

At the customer's request, OMRON will provide applicable third party certification documents identifying ratings and limitations of use that apply to the products. This information by itself is not sufficient for a complete determination of the suitability of the products in combination with the end product, machine, system, or other application or use.

The following are some examples of applications for which particular attention must be given. This is not intended to be an exhaustive list of all possible uses of the products, nor is it intended to imply that the uses listed may be suitable for the products:

- Outdoor use, uses involving potential chemical contamination or electrical interference, or conditions or uses not described in this catalog.
- Nuclear energy control systems, combustion systems, railroad systems, aviation systems, medical equipment, amusement machines, vehicles, safety equipment, and installations subject to separate industry or government regulations.
- Systems, machines, and equipment that could present a risk to life or property.

Please know and observe all prohibitions of use applicable to the products.

NEVER USE THE PRODUCTS FOR AN APPLICATION INVOLVING SERIOUS RISK TO LIFE OR PROPERTY WITHOUT ENSURING THAT THE SYSTEM AS A WHOLE HAS BEEN DESIGNED TO ADDRESS THE RISKS, AND THAT THE OMRON PRODUCTS ARE PROPERLY RATED AND INSTALLED FOR THE INTENDED USE WITHIN THE OVERALL EQUIPMENT OR SYSTEM.

PROGRAMMABLE PRODUCTS

OMRON shall not be responsible for the user's programming of a programmable product, or any consequence thereof.

Disclaimers

CHANGE IN SPECIFICATIONS

Product specifications and accessories may be changed at any time based on improvements and other reasons.

It is our practice to change model numbers when published ratings or features are changed, or when significant construction changes are made. However, some specifications of the products may be changed without any notice. When in doubt, special model numbers may be assigned to fix or establish key specifications for your application on your request. Please consult with your OMRON representative at any time to confirm actual specifications of purchased products.

DIMENSIONS AND WEIGHTS

Dimensions and weights are nominal and are not to be used for manufacturing purposes, even when tolerances are shown.

PERFORMANCE DATA

Performance data given in this catalog is provided as a guide for the user in determining suitability and does not constitute a warranty. It may represent the result of OMRON's test conditions, and the users must correlate it to actual application requirements. Actual performance is subject to the OMRON Warranty and Limitations of Liability.

ERRORS AND OMISSIONS

The information in this document has been carefully checked and is believed to be accurate; however, no responsibility is assumed for clerical, typographical, or proofreading errors, or omissions.

2012.8

In the interest of product improvement, specifications are subject to change without notice.

OMRON Corporation
Industrial Automation Company

<http://www.ia.omron.com/>

(c)Copyright OMRON Corporation 2012 All Right Reserved.