

### Monitor the Output of a UV Light Source through an Optical Fiber Cable

- Head Unit withstands temperatures of up to 300°C.
- Easy-to-read digital display of measurement values.
- Harmful UV light converted to visible light before performing measurements. This feature prevents deterioration of the Amplifier's light receiving element.



## Ordering Information



### Amplifier

Appearance	Connection method	Outputs	Transistor type	Model number
	Pre-wired cable	<ul style="list-style-type: none"> <li>• Judgement output</li> <li>• Answer-back output</li> <li>• Analog current or voltage output</li> </ul>	NPN	F3UV-XW11
				F3UV-XW11-1 (Five-times higher sensitivity)
			PNP	F3UV-XW41

### Head Unit

Appearance	Wavelength range of incident light	Max. temperature	Model number	Remarks
	200 to 370 nm	300°C (Use at temperatures below the Fiber Unit's rated operating temperature.)	F3UV-HM	Includes two M8 nuts and one mounting plate.

### Fiber Units

Compatible Amplifier Units	Compatible Head Units	Appearance	Max. temperature	Intensity range of incident light (see note)	Model number	Quantity
F3UV-XW11 (-1), F3UV-XW41	F3UV-HM	 M4 threads, 2 m	300°C	10 to 300 mW/cm <sup>2</sup>	F32-300	1
		 M4 threads, 2 m	70°C	10 to 300 mW/cm <sup>2</sup>	F32-70	

**Note:** The values given are for a standard UV light source with a central wavelength of 360 nm, measured with a standard illumination meter (and for use in combination with the specified Amplifier and Head Unit). The power range is one for which teaching to 100% is possible.

### ■ Accessories (Sold Separately)

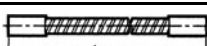
Appearance	Name	Model number	Quantity	Applicable Fiber Units
	Protective Tube (Protects the fiber.)	F39-FU1M	1	F32-70

# Specifications

## ■ Ratings/Characteristics

### Amplifiers

Item		F3UV-XW11 (-1)	F3UV-XW41
Power supply voltage		12 to 24 VDC $\pm 10\%$	
Current consumption		75 mA max.	
Outputs	Analog output	Current (4 to 20 mA) or voltage (1 to 5 V) (Monitoring mode or integral mode)	
	Judgement output	NPN open collector output, 100 mA max., residual voltage 1 V max.	PNP open collector output, 100 mA max., residual voltage 2 V max.
	Answer-back output	(Monitoring mode or integral mode)	(Monitoring mode or integral mode)
Inputs	Remote teaching input	ON: 0 V short-circuit (current 1 mA max.)	ON: Power supply voltage short-circuit or 9 to 24 V (open-circuit current: 3 mA max.)
	Reset input	OFF: Open (open or 9 to 24 V)	OFF: Open (open or 1.5 V max.)
Protective circuits		Reversed power supply polarity protection and output short-circuit protection	
Response time <sup>1</sup>		500 ms max.	
Sensitivity setting		Teaching function	
Indicators		Power supply/Teaching indicator (green/red), Operation indicator (orange), 7-segment digital percentage display (red), 7-segment digital threshold display (red)	
Repetitive accuracy		$\pm 2\%$ F.S. max.	
Ambient operating illumination <sup>2</sup>		Fluorescent light 1,000 lx max.	
Temperature drift		$\pm 0.1\%$ of F.S./ $^{\circ}\text{C}$ max.	
Ambient temperature		Operating: $-25$ to $55^{\circ}\text{C}$ (with no icing or condensation) Storage: $-40$ to $70^{\circ}\text{C}$ (with no icing or condensation)	
Ambient humidity		Operating or storage: 35% to 85%	
Insulation resistance		20 M $\Omega$ min. (at 500 VDC)	
Dielectric strength		1,000 V AC 50/60 Hz between the leads and the case	
Vibration resistance		10 to 150 Hz, 0.1-mm amplitude or 15 m/s <sup>2</sup> in X, Y, and Z directions each for 2 hours	
Shock resistance		150 m/s <sup>2</sup> three times each in the X, Y, and Z directions	
Degree of protection		Conforms to IEC 60529 standards IP30	
Connection method		Pre-wired cable with a standard length of 2 m	
Weight (packed)		Approx. 270 g	
Material		ABS plastic	
Accessories		Operation Manual	

- Note:**
- The response time is the rise time or fall time of the output signal to 10 to 90%.
  - The ambient operating illumination is the illumination that changes the analog output  $+5\%$  F.S. at 200 lx; it is not the operational limit.
  - An analog output of up to 6 V (or 24 mA) can be output. The output is 1 V (or 4 mA) when there is no incident UV light.
  - F.S. stands for full scale. For a current output, full scale is 16 mA (4 to 20 mA). For a voltage output, full scale is 4 V (1 to 5 V).
  - Definition of the luminous energy integral: The physical unit of the luminous energy integral is energy (J: joules) and this value is calculated by multiplying the UV intensity (mV) by the time of exposure (s), but it is dimensionless when this sensor's analog output value (V) is used for the UV intensity. The integral is measured with an 11 ms sampling time.

### Head Unit

Item		F3UV-HM
Incident light wavelength range		200 to 370 nm
Temperature drift		$-0.15\%$ / $^{\circ}\text{C}$ max.
Ambient temperature		Operating or storage: $-40^{\circ}$ to $300^{\circ}\text{C}$ (with no icing or condensation)
Ambient humidity		Operating or storage: 35% to 85% (with no icing or condensation)
Weight (packed)		Approx. 300 g
Vibration resistance		10 to 55 Hz, 0.75-mm amplitude or 10 m/s <sup>2</sup>
Shock resistance		500 m/s <sup>2</sup>
Material	Protective casing	Stainless steel (SUS303)
	Fluorescent fiber path	Functional fluoroglass
Accessories		M8 nut and mounting bracket

Fiber Units

Item	Model	
	F32-300	F32-70
<b>Ambient temperature (with no icing or condensation)</b>	Operating: -40° to 300°C*1 Storage: -40° to 110°C	Operating: -40° to 70°C Storage: -40° to 70°C
<b>Ambient humidity (with no icing or condensation)</b>	Operating: 35 to 85% Storage: 35 to 95%	
<b>Bending radius</b>	25 mm min.	25 mm min.
<b>Fiber outer sheathing material</b>	SUS	Black polyethylene
<b>Degree of protection</b>	Conforms to IEC IP67	
<b>Standard fiber length</b>	2 m	

**Note:** The maximum temperature is lower near the amplifier unit. See the Dimensions for details.

**Accessories (Sold Separately)**

**Protective Tube (Protects the Fiber.)**

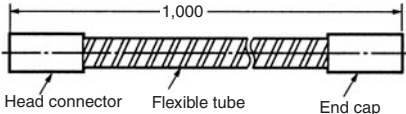
Item	F39-FU1M	
	 <p>The diagram shows a cross-section of the protective tube assembly. It consists of a 'Head connector' on the left, a 'Flexible tube' in the middle with a length of 1,000 mm, and an 'End cap' on the right. The flexible tube is shown with diagonal hatching to indicate its flexibility.</p>	
<b>Ambient temperature</b>	-40° to 150°C for operation and storage (Keep the ambient temperature within the range specified for the fiber within the tube.)	
<b>Ambient humidity</b>	Operating: 35 to 85% Storage: 35 to 95%	
<b>Bending radius</b>	30 mm min.	
<b>Max. pulling force</b>	1.5 N·m max. between the head connector and tube, 1.5 N·m max. between the end cap and tube, and 2 N·m on the tube itself	
<b>Crush weight</b>	29.4 N·m max. on the tube	
<b>Material</b>	<b>Head connector</b>	Nickel-plated brass
	<b>End cap</b>	
	<b>Tube</b>	Stainless (SUS304)

# Engineering Data

## Output Characteristics

F3UV-XW□1 + F3UV-HM + F32-300

(Output characteristics when the sensitivity is set at 300 mW/cm<sup>2</sup>.)

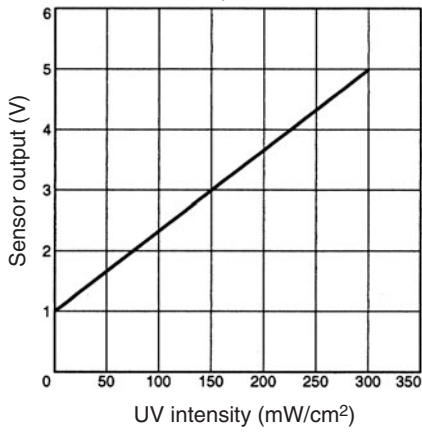

## Angular Characteristics (Y-direction)

F3UV-HM

The output variation in the X-direction is less than ±10% of F.S. in a full 360° rotation.

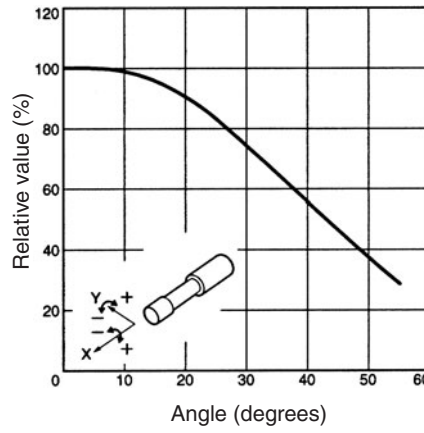

## Output Characteristics

F3UV-XW11-1 + F3UV-HM + F32-70

(Output characteristics when the output is set at 5V for a UV intensity of 60 mW/cm<sup>2</sup>.)

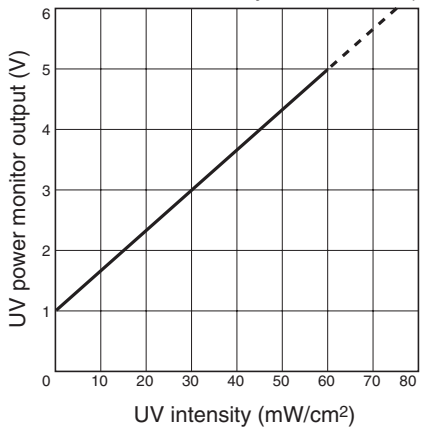

## Sensitivity Characteristics

All F3UV Models

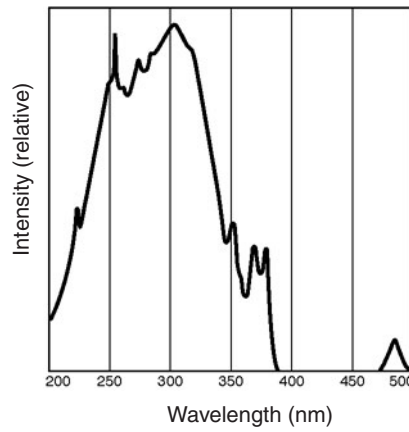

# Nomenclature

## F3UV-XW11 (-1) /-XW41

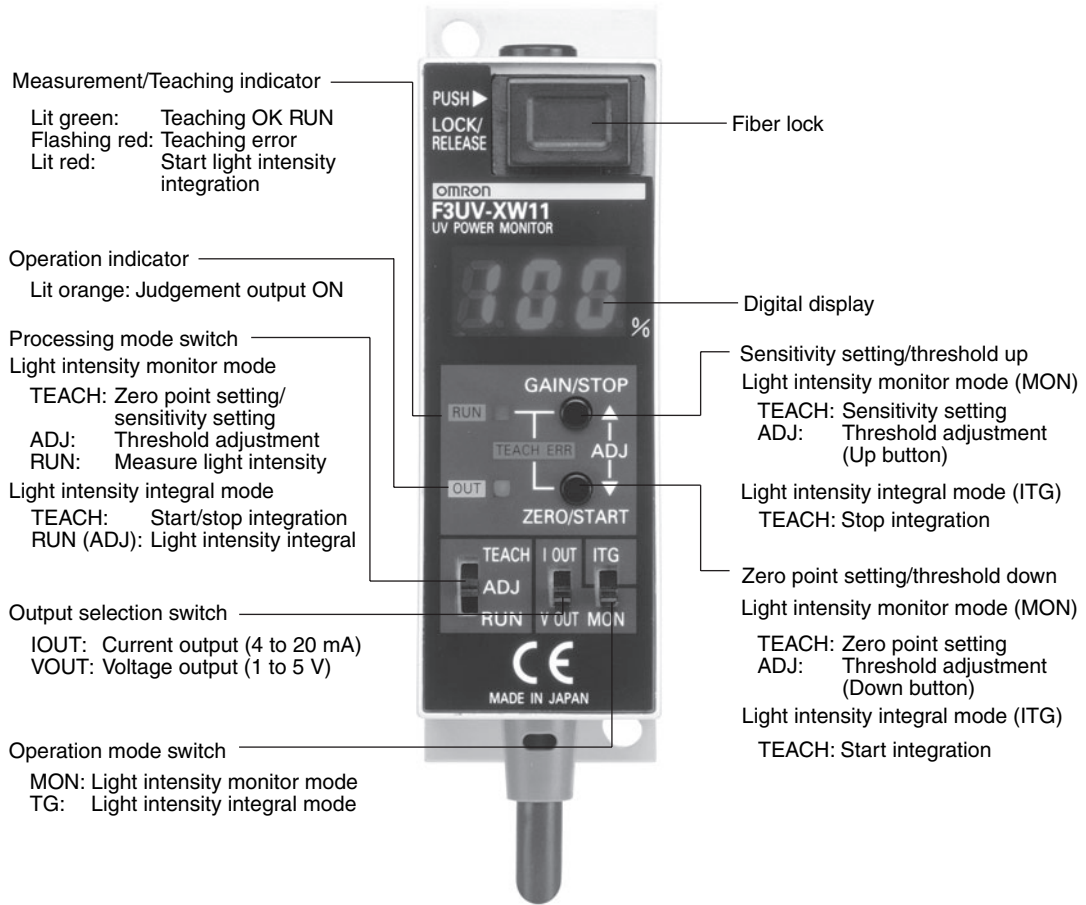

Functions

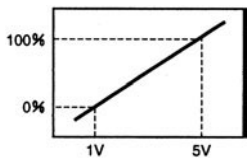
Name	Function
Indicator functions	
Measurement/teaching indicator	<ul style="list-style-type: none"> <li>• Lit green: Teaching OK RUN</li> <li>• Flashing red: Teaching error</li> <li>• Lit red: Start light intensity integration</li> </ul>
Operation indicator	<ul style="list-style-type: none"> <li>• Lit orange: Judgement output ON</li> </ul>
Digital display	<ul style="list-style-type: none"> <li>• Percentage display when operating in light intensity monitor mode HI: Greater than 124% LO: Less than 0%</li> </ul>
Output functions	
Analog output (switchable)	<ul style="list-style-type: none"> <li>• Outputs a current (4 to 20 mA) or voltage (1 to 5 V) that is proportional to the incident light intensity. Select current or voltage output with the output selection switch.</li> </ul>
Judgement output	<ul style="list-style-type: none"> <li>• ON when the incident light intensity is below the set threshold value.</li> <li>• OFF when the incident light intensity is above the set threshold value. (Includes a short-circuit protection function.)</li> </ul>
Answer-back output	<ul style="list-style-type: none"> <li>• A one pulse output (1 sec) is generated when remote teaching has been completed normally.</li> </ul>
Input functions	
Reset input	<ul style="list-style-type: none"> <li>• This trigger signal starts integration when the Unit is in integral mode and the processing mode is set to "RUN".</li> </ul>
Remote teaching input	<ul style="list-style-type: none"> <li>• When the Unit is in monitor mode or integral mode, teaching is performed when a pulse signal is input here.</li> </ul>
Threshold setting function (monitor mode only)	<ul style="list-style-type: none"> <li>• The desired threshold value can be set by pressing the Up and Down buttons. (The digital display will change in 1% increments when the value is set.)</li> </ul>
Sensitivity setting function (monitor mode only)	
Zero point setting	<ul style="list-style-type: none"> <li>• Sets the zero point reference when the UV light source is OFF. After teaching, the digital display will read "0%".</li> </ul>
Sensitivity setting	<ul style="list-style-type: none"> <li>• Sets the initial sensitivity when the UV light source is ON. After teaching, the digital display will read "100%".</li> </ul>
Max. sensitivity setting	<ul style="list-style-type: none"> <li>• Sets the sensor sensitivity to the maximum sensitivity.</li> </ul>
Min. sensitivity setting	<ul style="list-style-type: none"> <li>• Sets the sensor sensitivity to the minimum sensitivity.</li> </ul>
Light intensity monitor function (Part of the current/voltage output switching function.)	<ul style="list-style-type: none"> <li>• Displays the digital (%) value corresponding to the incident light intensity and outputs the analog and judgement outputs.</li> </ul> 
Light intensity integral function (Part of the current/voltage output switching function.)	<ul style="list-style-type: none"> <li>• Calculates the light intensity integral value (I) from the incident light intensity (P) and time (T) using the following equation: <math>I = P \times T</math>. Also outputs the integral's analog output simultaneously and displays the digital (%) value. (Output ON at 100%.)</li> </ul>

# Operation

## I/O Circuit Configuration

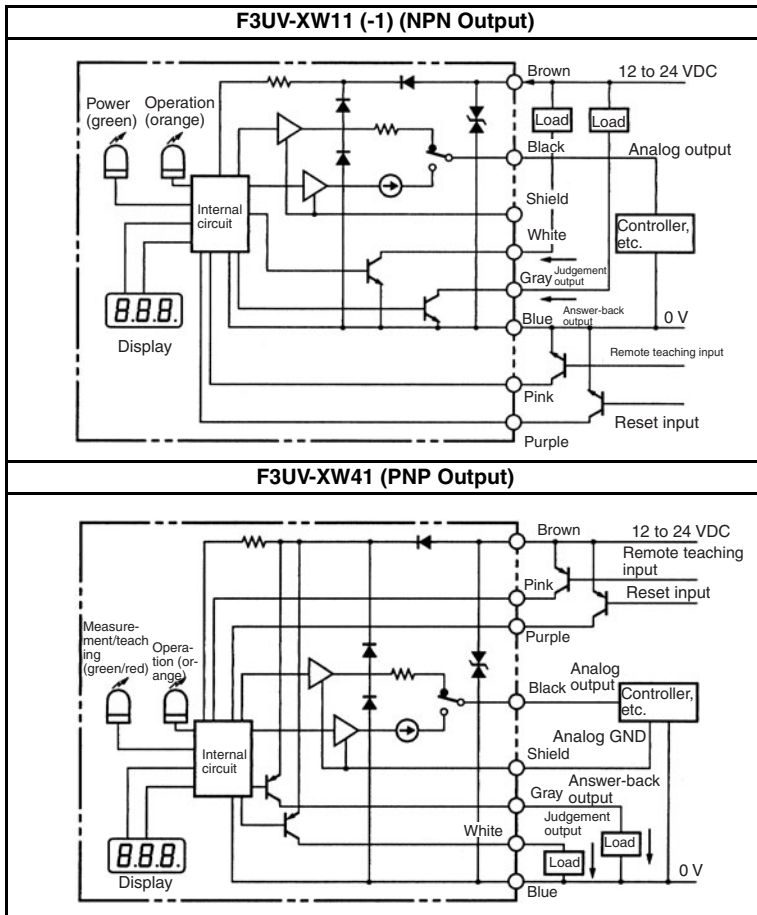

# Dimensions

**Note:** All units are in millimeters unless otherwise indicated.

## Main Units

### Amplifier

### F3UV-XW11 (-1) /-XW41

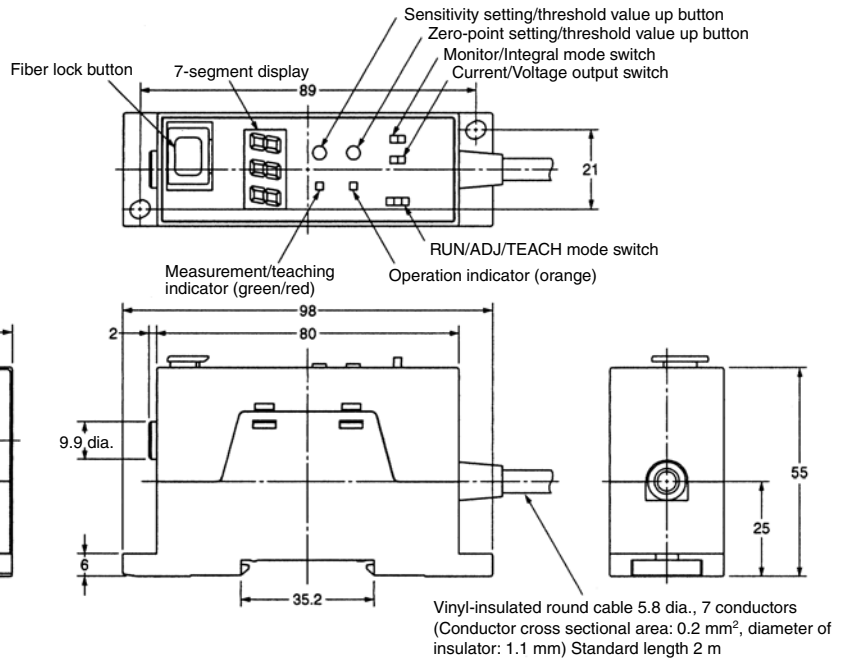
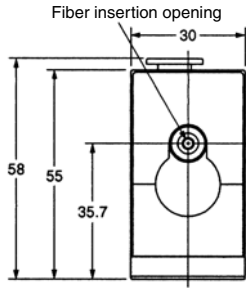
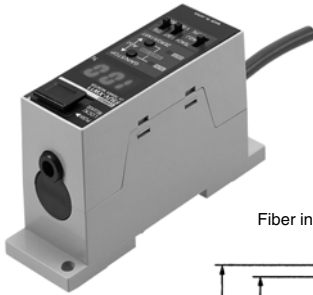

### Mounting Hole Dimensions

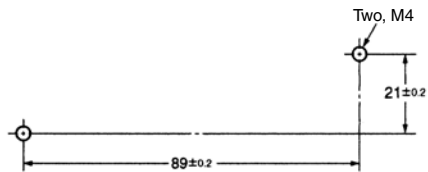



**Base Unit  
F3UV-HM**

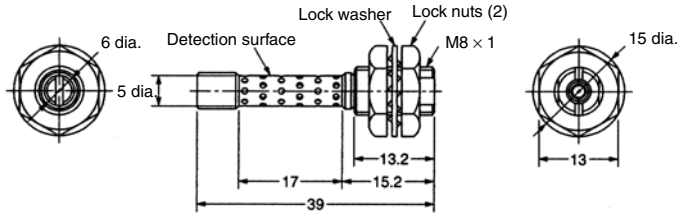

Material: Stainless steel (SUS303)

**Fiber Unit  
F32-300**

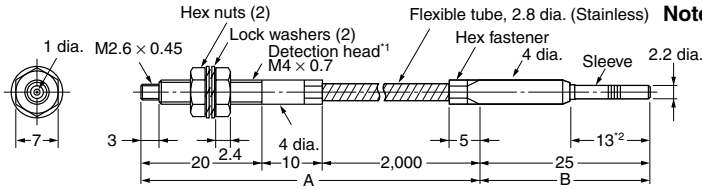

**Note:** The max. temperature is 300°C in section A and 110°C in section B, which connects to the Main Unit. The part of section B that is actually inserted into the Main Unit must remain within the Main Unit's rated operating temperature range.

\*1: Material: Stainless steel (SUS303)

**Fiber Unit  
F32-70 (Cuttable)**

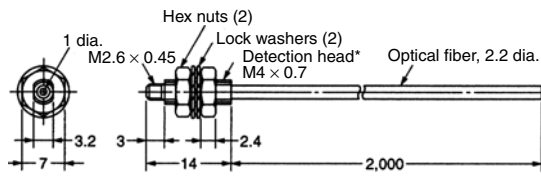

\*Material: Nickel-plated brass

**Note:** The "cuttable" Fiber Units can be cut to length. Units that are not marked "cuttable" cannot be cut to length.

**Accessories (Sold Separately)**

**Protective Tube (Protects the Fiber.)  
F32-FU1M**

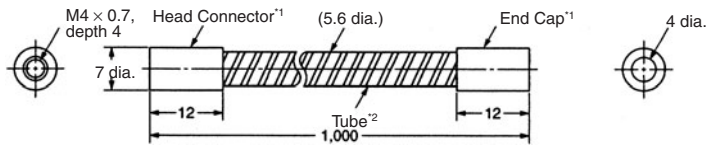

**Note:** 1. Material: Nickel-plated brass  
2. Material: Stainless steel (SUS304)

## Precautions

Be sure to observe the precautions listed here. These precautions are essential for safe operation.

- Do not use these Units in locations with flammable or explosive gases.
- Do not use these Units in water.
- Do not attempt to disassemble, repair, or improve these products.
- Always use a power supply voltage that is within the specified operating range. Do not use with an AC power supply.

- Be sure that wiring is correct, such as the polarity of the power supply leads.
- Connect loads properly.
- Do not short-circuit the load's terminals.
- Do not mount the Amplifier Unit in a location where it will be exposed to UV light.

### ■ Precautions Common to the Amplifiers

#### Wiring

##### Connections

Make sure that the power supply voltage is below the maximum voltage before turning the power ON.

Be sure that the terminal polarity and wiring are correct.

Never share a conduit that is used for high-voltage or power lines.

Use extension cords with a minimum thickness of 0.3 mm<sup>2</sup>, less than 5 m long, and check operation before using.

##### Power Supply

When using a commercial switching regulator, ground the FG (frame ground) and G (ground) terminals. Output signal noise will be excessive if the power supply is not grounded.

After turning on the power supply, wait for at least one second until consistent detections can be performed before using the Monitor. If separate power supplies are used for the F3UV and connected devices, always turn ON the F3UV's power supply first.

#### Installation and Operation

##### Installation

UV light is harmful, so be sure to turn OFF the UV light source before installing the F3UV.

##### Sensitivity Setting

The analog output value will change due to temperature drift. If the temperature is rising, wait for the temperature to stabilize before setting the sensitivity.

##### Installation

###### 1. Installation Torque

Torque the sensor's Main Unit screws to 0.49 N·m max.

###### 2. Using DIN Track (Installation)

1. Hook the top of the Unit onto the DIN Track.
2. Snap the bottom of the Unit onto the DIN Track.

**Note:** Do not reverse steps 1 and 2.

###### (Removal)

When removing the Unit from the DIN Track, pull the mounting hook forward to release it.

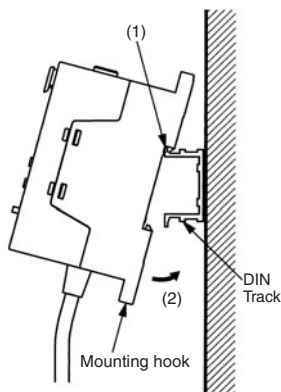

#### Precautions Regarding UV Light

The Amplifier itself is not protected against UV exposure. Do not install the Amplifier in locations where it will be exposed to UV light.

#### Adjustment

##### Basic Operating Procedures

1. Install the Amplifier Unit.
2. Connect the Fiber Unit to the Amplifier Unit.
3. Turn ON the power supply.
4. Select an operating mode with the operation mode switch. (Light intensity monitor mode or light intensity integral mode)
5. When using the analog output, select current or voltage output with the output selection switch.
6. Set the processing mode switch to TEACH and perform the teaching operation.
  - Light Intensity Monitor Mode  
Make the zero-point setting when the indicator is not lit and make the sensitivity setting when the indicator is lit. (Make the sensitivity setting after the temperature has stabilized.)
  - Light Intensity Integral Mode  
Use the start setting at the start of illumination and the stop setting when completed. Teaching can be performed by pressing the buttons or with codes.
7. When changing the threshold value in light intensity monitor mode, set the processing mode switch to ADJ and adjust the threshold value. The judgement output will go ON when the light intensity is below the threshold value. The threshold value is set to 50 at the factory.
8. Set the processing mode switch to RUN to start measurement. In light intensity integral mode, start integration with the Reset input.

#### Cleaning

Never use paint thinner or mineral spirits of any kind.

## ■ Fiber Unit/Base Unit

### Installation

#### Installing the Head Unit

When connecting the Head Unit and Fiber Unit, tighten to a torque of 0.78 N·m max. When installing the Head Unit, be sure to turn OFF the UV light source and check that it is safe to install the Unit.

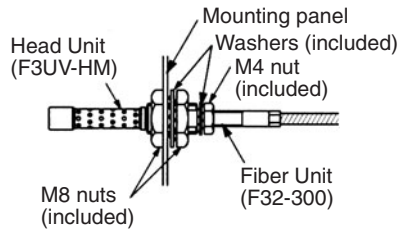

#### Installing the Fiber Unit and Amplifier Unit

The quality of the connection between the Fiber Unit and Amplifier Unit has a major impact on the operating characteristics, so be sure to connect these Units securely.

#### Securing the Fiber Unit

1. Cutting the Fiber (F32-70 only)
  - Insert the fiber into the hole of the cutting tool and set the tool at the desired length.
  - Press down on the blade and cut the fiber. Do not stop when the fiber is only partially cut; make one clean cut.
  - Once a hole has been used to cut a fiber, do not use that hole again. The cut surface may not be clean enough and the detection characteristics may be degraded.
2. Installing the Fiber
 

With the lock button in the release position, insert the fiber into the Unit and press the button until you hear a click. This click is the sound of the fiber being locked.

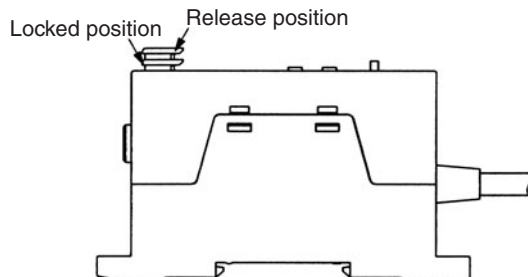

3. Removing the Fiber
 

Press the lock button again. The lock will be released, the lock button will pop up, and it will be possible to remove the fiber. Do not force the lock button up by pulling on it. (To maintain the fiber's characteristics, check whether the lock is out of place.)
4. Fiber Insertion Location
 

When inserting the Fiber Unit into the Amplifier Unit, always insert the Fiber Unit completely as shown in the following diagram.

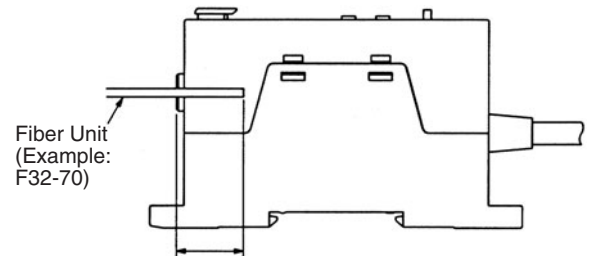
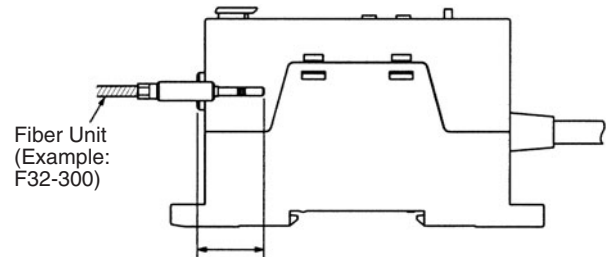

5. Fiber Unit Installation/Removal Precautions
 

Install and remove the Fiber Unit only when the ambient temperature is between  $-40$  and  $40^{\circ}\text{C}$ .
6. Protecting the Fiber Unit
 

When the outer sheathing of a Fiber Unit other than the F32-300 will be exposed to UV light, protect the fiber by covering it with the F39-FU1M Protective Tube.

**ALL DIMENSIONS SHOWN ARE IN MILLIMETERS.**

To convert millimeters into inches, multiply by 0.03937. To convert grams into ounces, multiply by 0.03527.

CSM\_F3UV\_DS\_E\_3\_1  
E315-E1

**In the interest of product improvement, specifications are subject to change without notice.**

## **OMRON Corporation**

**Industrial Automation Company**

**Sensing Devices Division H.Q.**

**Application Sensors Division**

Shiokoji Horikawa, Shimogyo-ku,

Kyoto, 600-8530 Japan

Tel: (81)75-344-7068/Fax: (81)75-344-7107

## Read and Understand This Catalog

Please read and understand this catalog before purchasing the products. Please consult your OMRON representative if you have any questions or comments.

## Warranty and Limitations of Liability

### WARRANTY

OMRON's exclusive warranty is that the products are free from defects in materials and workmanship for a period of one year (or other period if specified) from date of sale by OMRON.

OMRON MAKES NO WARRANTY OR REPRESENTATION, EXPRESS OR IMPLIED, REGARDING NON-INFRINGEMENT, MERCHANTABILITY, OR FITNESS FOR PARTICULAR PURPOSE OF THE PRODUCTS. ANY BUYER OR USER ACKNOWLEDGES THAT THE BUYER OR USER ALONE HAS DETERMINED THAT THE PRODUCTS WILL SUITABLY MEET THE REQUIREMENTS OF THEIR INTENDED USE. OMRON DISCLAIMS ALL OTHER WARRANTIES, EXPRESS OR IMPLIED.

### LIMITATIONS OF LIABILITY

OMRON SHALL NOT BE RESPONSIBLE FOR SPECIAL, INDIRECT, OR CONSEQUENTIAL DAMAGES, LOSS OF PROFITS OR COMMERCIAL LOSS IN ANY WAY CONNECTED WITH THE PRODUCTS, WHETHER SUCH CLAIM IS BASED ON CONTRACT, WARRANTY, NEGLIGENCE, OR STRICT LIABILITY.

In no event shall the responsibility of OMRON for any act exceed the individual price of the product on which liability is asserted.

IN NO EVENT SHALL OMRON BE RESPONSIBLE FOR WARRANTY, REPAIR, OR OTHER CLAIMS REGARDING THE PRODUCTS UNLESS OMRON'S ANALYSIS CONFIRMS THAT THE PRODUCTS WERE PROPERLY HANDLED, STORED, INSTALLED, AND MAINTAINED AND NOT SUBJECT TO CONTAMINATION, ABUSE, MISUSE, OR INAPPROPRIATE MODIFICATION OR REPAIR.

## Application Considerations

### SUITABILITY FOR USE

OMRON shall not be responsible for conformity with any standards, codes, or regulations that apply to the combination of products in the customer's application or use of the products.

At the customer's request, OMRON will provide applicable third party certification documents identifying ratings and limitations of use that apply to the products. This information by itself is not sufficient for a complete determination of the suitability of the products in combination with the end product, machine, system, or other application or use.

The following are some examples of applications for which particular attention must be given. This is not intended to be an exhaustive list of all possible uses of the products, nor is it intended to imply that the uses listed may be suitable for the products:

- Outdoor use, uses involving potential chemical contamination or electrical interference, or conditions or uses not described in this catalog.
- Nuclear energy control systems, combustion systems, railroad systems, aviation systems, medical equipment, amusement machines, vehicles, safety equipment, and installations subject to separate industry or government regulations.
- Systems, machines, and equipment that could present a risk to life or property.

Please know and observe all prohibitions of use applicable to the products.

NEVER USE THE PRODUCTS FOR AN APPLICATION INVOLVING SERIOUS RISK TO LIFE OR PROPERTY WITHOUT ENSURING THAT THE SYSTEM AS A WHOLE HAS BEEN DESIGNED TO ADDRESS THE RISKS, AND THAT THE OMRON PRODUCTS ARE PROPERLY RATED AND INSTALLED FOR THE INTENDED USE WITHIN THE OVERALL EQUIPMENT OR SYSTEM.

### PROGRAMMABLE PRODUCTS

OMRON shall not be responsible for the user's programming of a programmable product, or any consequence thereof.

## Disclaimers

### CHANGE IN SPECIFICATIONS

Product specifications and accessories may be changed at any time based on improvements and other reasons.

It is our practice to change model numbers when published ratings or features are changed, or when significant construction changes are made. However, some specifications of the products may be changed without any notice. When in doubt, special model numbers may be assigned to fix or establish key specifications for your application on your request. Please consult with your OMRON representative at any time to confirm actual specifications of purchased products.

### DIMENSIONS AND WEIGHTS

Dimensions and weights are nominal and are not to be used for manufacturing purposes, even when tolerances are shown.

### PERFORMANCE DATA

Performance data given in this catalog is provided as a guide for the user in determining suitability and does not constitute a warranty. It may represent the result of OMRON's test conditions, and the users must correlate it to actual application requirements. Actual performance is subject to the OMRON Warranty and Limitations of Liability.

### ERRORS AND OMISSIONS

The information in this document has been carefully checked and is believed to be accurate; however, no responsibility is assumed for clerical, typographical, or proofreading errors, or omissions.

2011.4

In the interest of product improvement, specifications are subject to change without notice.

**OMRON Corporation**  
Industrial Automation Company

<http://www.ia.omron.com/>

(c)Copyright OMRON Corporation 2011 All Right Reserved.