

Connector Terminal Box (Muting Terminals for F3SJ-A)

F39-TC5

CSM_F39-TC5_DS_E_3_1

Significantly reduces amount of wiring between Safety Light Curtains and Muting Sensors.

As of August 2008

- Provides IP67 protection against water and dust.
- Connection using connectors significantly reduces wiring work.
- The wiring status can be checked at a glance with the LED indicators.
- The Support Software can be connected, enabling on-site adjustment of a Light Curtain.





 Be sure to read the "Safety Precautions" on page 7 and the "Precautions for All Safety Sensors".

Ordering Information

Connector Terminal Box

Classification	Applicable models	Specification	Type	Model
Muting Terminals	F3SJ-A□□□□P□□	PNP	Model with Muting Sensor Output Mode	F39-TC5P01
			Model with Override Mode	F39-TC5P02
	F3SJ-A□□□□N□□	NPN	Model with Muting Sensor Output Mode	F39-TC5N01
			Model with Override Mode	F39-TC5N02

Optional Accessories (Sold separately)

Classification	Appearance	Model
Short-circuit Connector		F39-CN8
Waterproof Covers		XS2Z-22

Note: One short-circuit connector is included with the F39-T□□01 for Muting Sensors.
 Three waterproof covers are included with a Connector Terminal Box with Muting Sensor Output Mode (F39-TC5□□01) and four waterproof covers with a Connector Terminal Box with Override Mode (F39-TC5□□02).
 Order the above accessories only as spare parts.

Specifications (Refer to Instruction Sheet for details.)

Ratings

Rated voltage	24 VDC ±20% (at ambient temperature of 20°C)
Rated current	Power line: 2.4 A, Signal line: 0.3 A

Characteristics

Contact resistance	40 mΩ max. (connector section)
Insulation resistance	After applying 500 VDC for 60 s: 100 MΩ min.
Vibration resistance	Speed: 10 Hz to 500 Hz to 10 Hz in 20 minutes. Simple vibration with full amplitude of 1.52 mm or 98 m/s ² (whichever has the smaller amplitude) for two hours each in three directions X, Y, and Z (total of 6 hours). Measured while connector is connected.
Shock resistance	490 m/s ² for 11 ms three times each along three axes, six directions X, Y, and Z (total of 18 times). Measured while connector is connected. (MIL-STD-202F Test 213B, Condition A)
Ambient operating temperature	-25 to 70°C (with no icing or condensation)
Ambient operating humidity	25% to 85% (with no icing or condensation)
Degree of protection	IP67
Accessories	Short-circuit connector (models with Muting Sensor outputs only), waterproof cover

Connections

Internal Circuit Diagrams

PNP

Model with Muting Sensor Output Mode F39-TC5P01

Note: When a short-circuit connector is connected to CN1, terminals 1 and 2, and terminals 3 and 4 will be short-circuited. This connects the Muting Sensor input to muting input 1 and muting input 2 of the F3SJ.

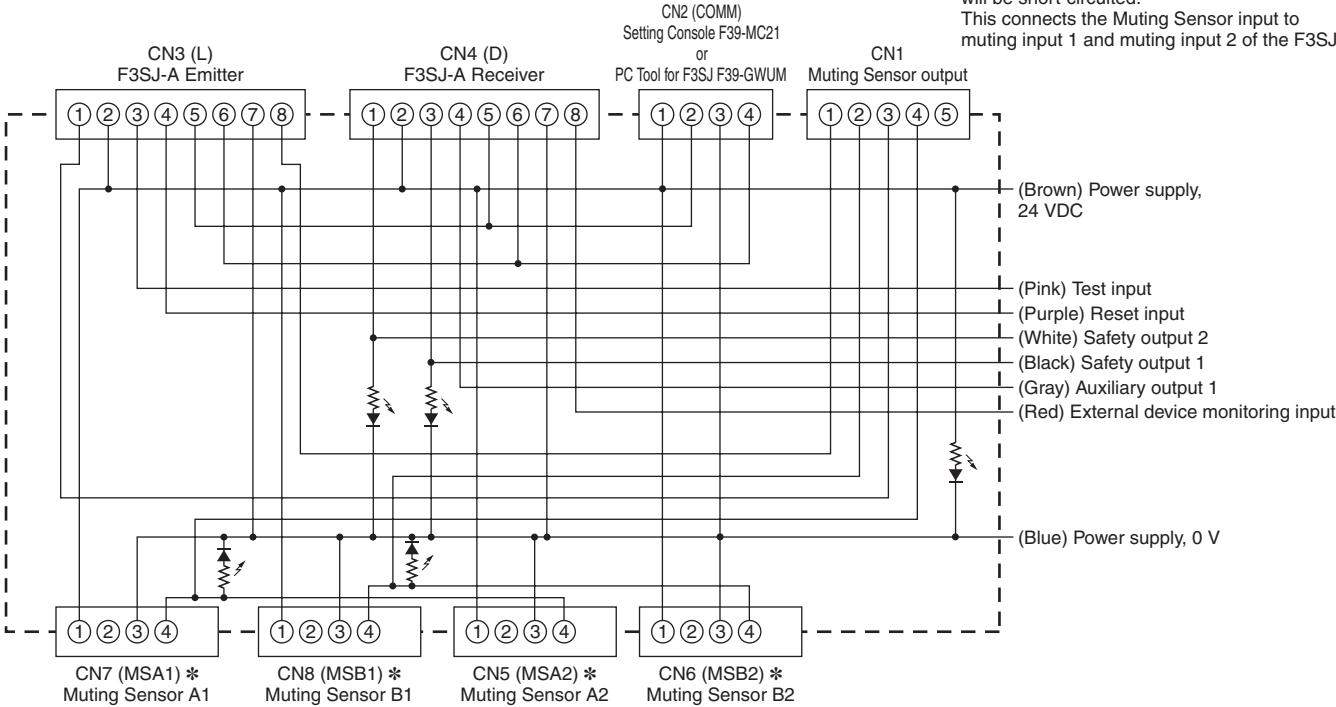

* Use the following connecting cable to connect the Muting Sensors:
 M12, 4-pin connector (Pin 1: +24 V, Pin 2: Not used, Pin 3: 0 V, Pin 4: Output)
 When using a Through-beam Photoelectric Sensor, use an XS2R-D426-□11-F Y-joint with Socket and Plug or similar product to connect the transmitter and receiver.

Model with Override Mode F39-TC5P02

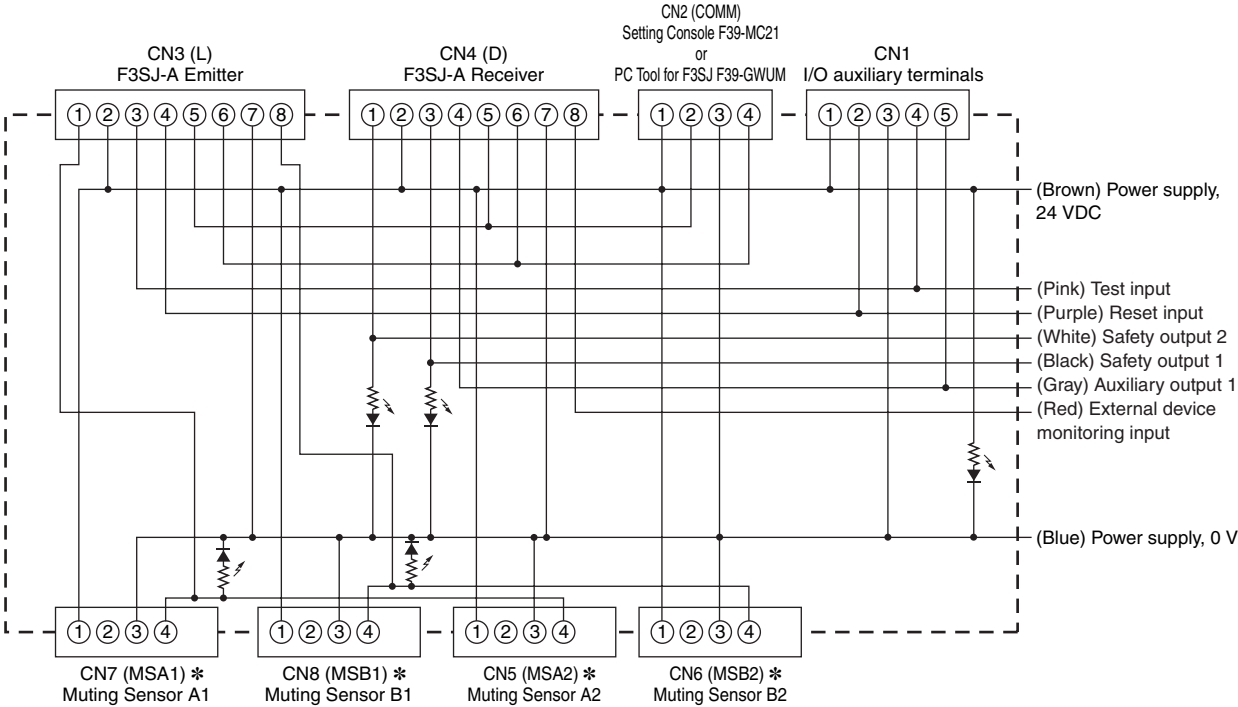

* Use the following connecting cable to connect the Muting Sensors:
 M12, 4-pin connector (Pin 1: +24 V, Pin 2: Not used, Pin 3: 0 V, Pin 4: Output)
 When using a Through-beam Photoelectric Sensor, use an XS2R-D426-□11-F Y-joint with Socket and Plug or similar product to connect the transmitter and receiver.

NPN

Model with Muting Sensor Output Mode F39-TC5N01

Note: When a short-circuit connector is connected to CN1, terminals 1 and 2, and terminals 3 and 4 will be short-circuited. This connects the Muting Sensor input to muting input 1 and muting input 2 of the F3SJ.

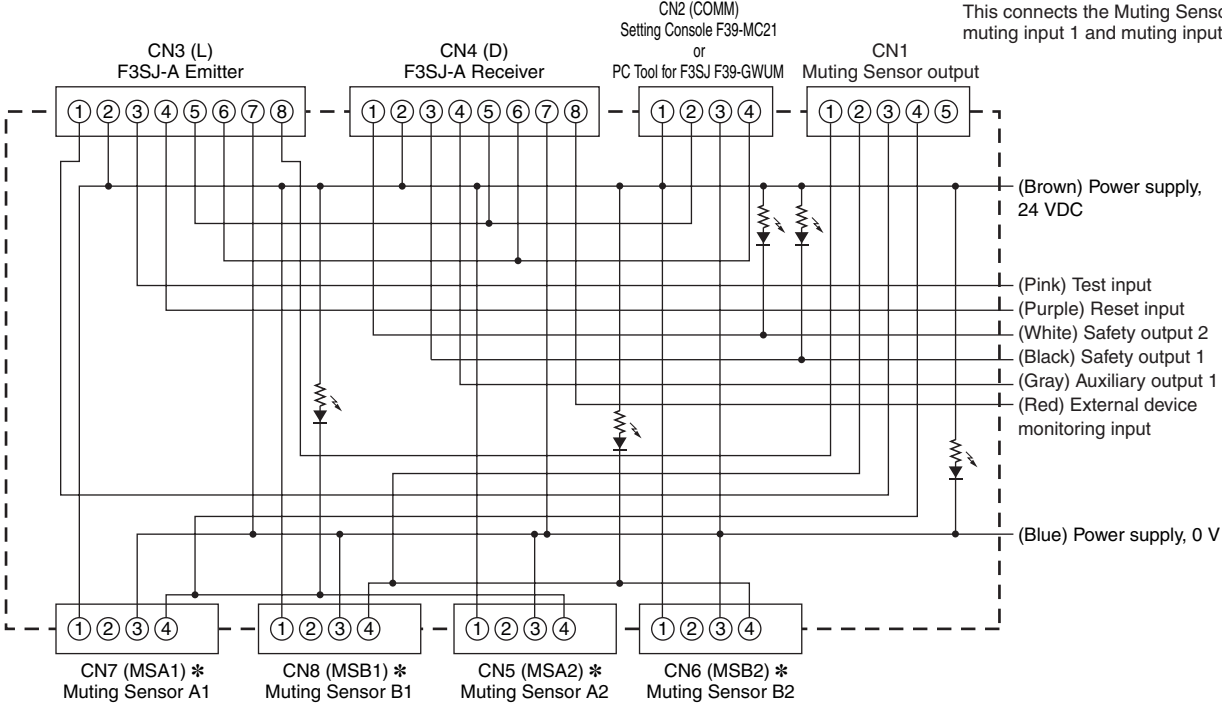

* Use the following connecting cable to connect the Muting Sensors:
M12, 4-pin connector (Pin 1: +24 V, Pin 2: Not used, Pin 3: 0 V, Pin 4: Output)
When using a Through-beam Photoelectric Sensor, use an XS2R-D426-□11-F Y-joint with Socket and Plug or similar product to connect the transmitter and receiver.

Model with Override Mode F39-TC5N02

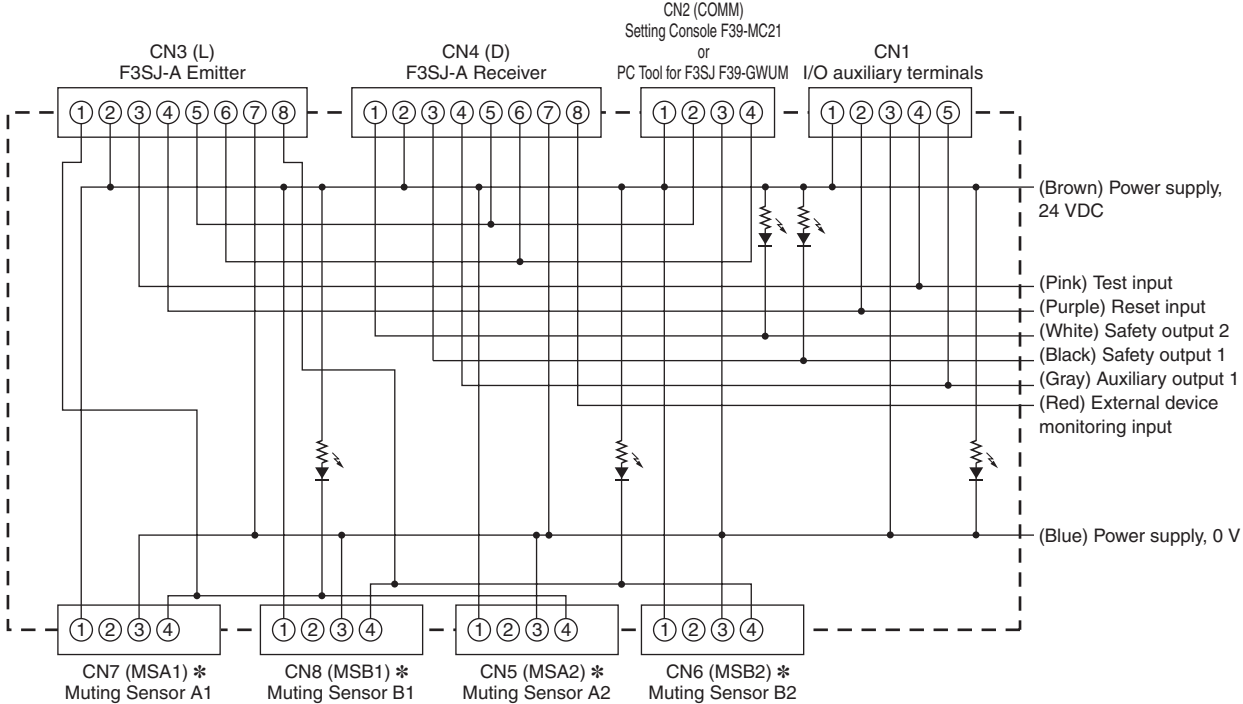

* Use the following connecting cable to connect the Muting Sensors:
M12, 4-pin connector (Pin 1: +24 V, Pin 2: Not used, Pin 3: 0 V, Pin 4: Output)
When using a Through-beam Photoelectric Sensor, use an XS2R-D426-□11-F Y-joint with Socket and Plug or similar product to connect the transmitter and receiver.

Wiring Diagrams

PNP

Model with Muting Sensor Output Mode F39-TC5P01

Note: The Key Cap for Muting and the Muting Lamp can be connected to either the Emitter or the Receiver.

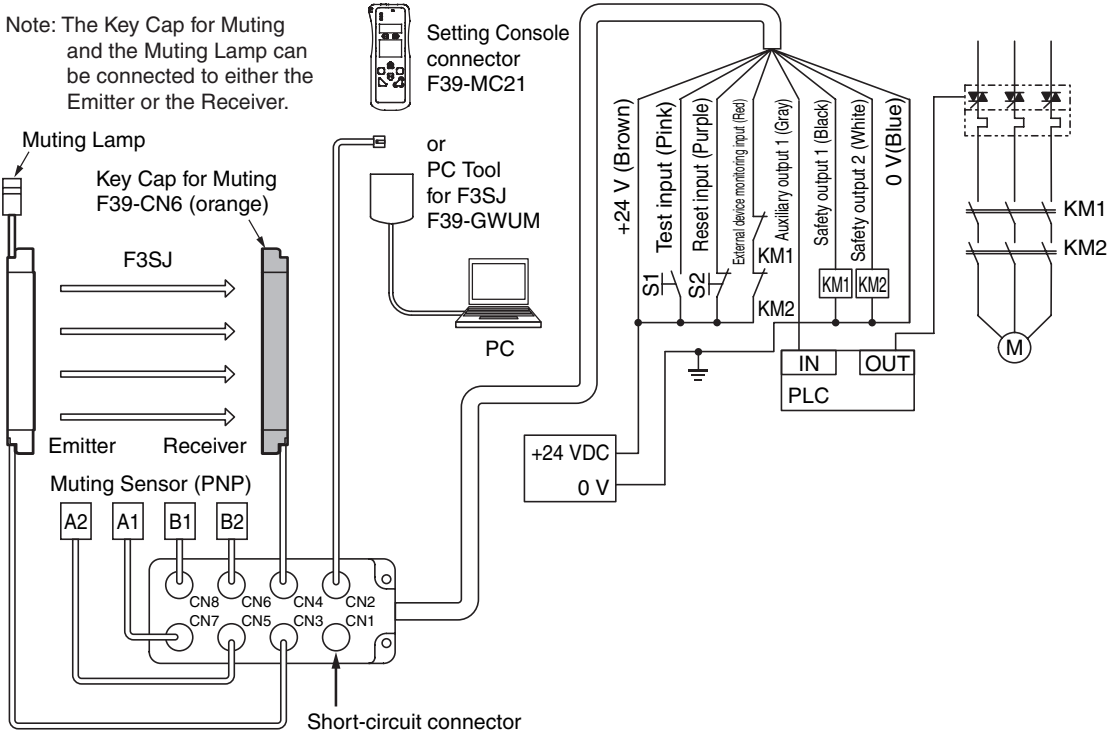

Model with Override Mode F39-TC5P02

Note: The Key Cap for Muting and the Muting Lamp can be connected to either the Emitter or the Receiver.

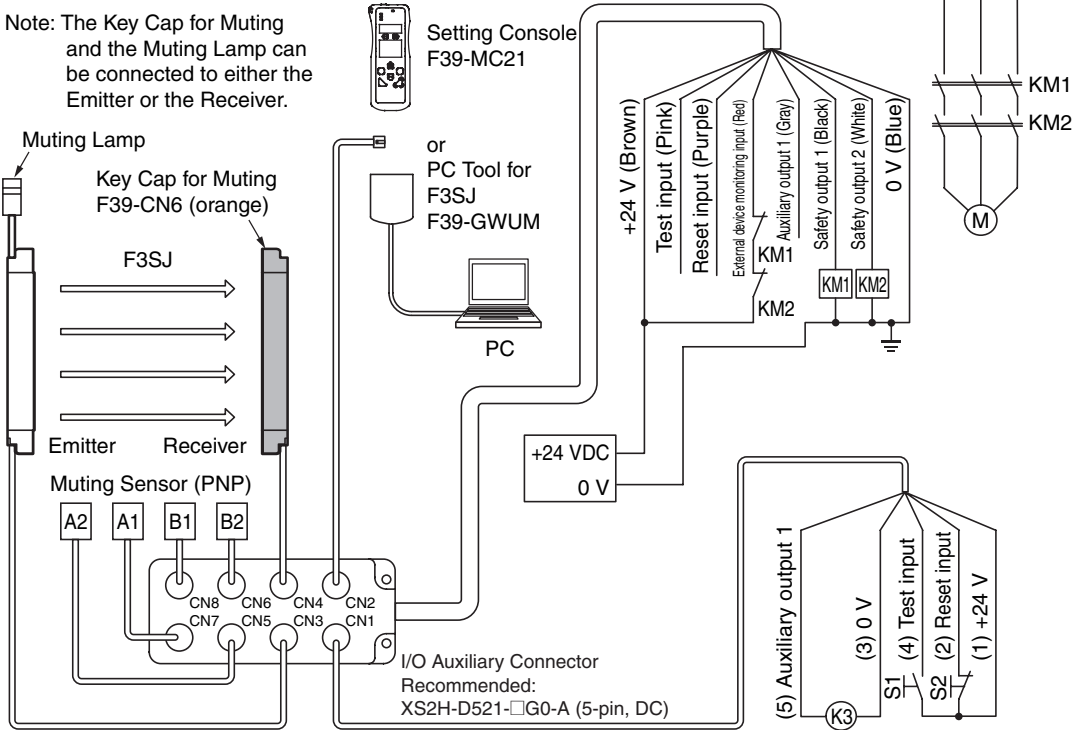

NPN

Model with Muting Sensor Output Mode F39-TC5N01

Note: The Key Cap for Muting and the Muting Lamp can be connected to either the Emitter or the Receiver.

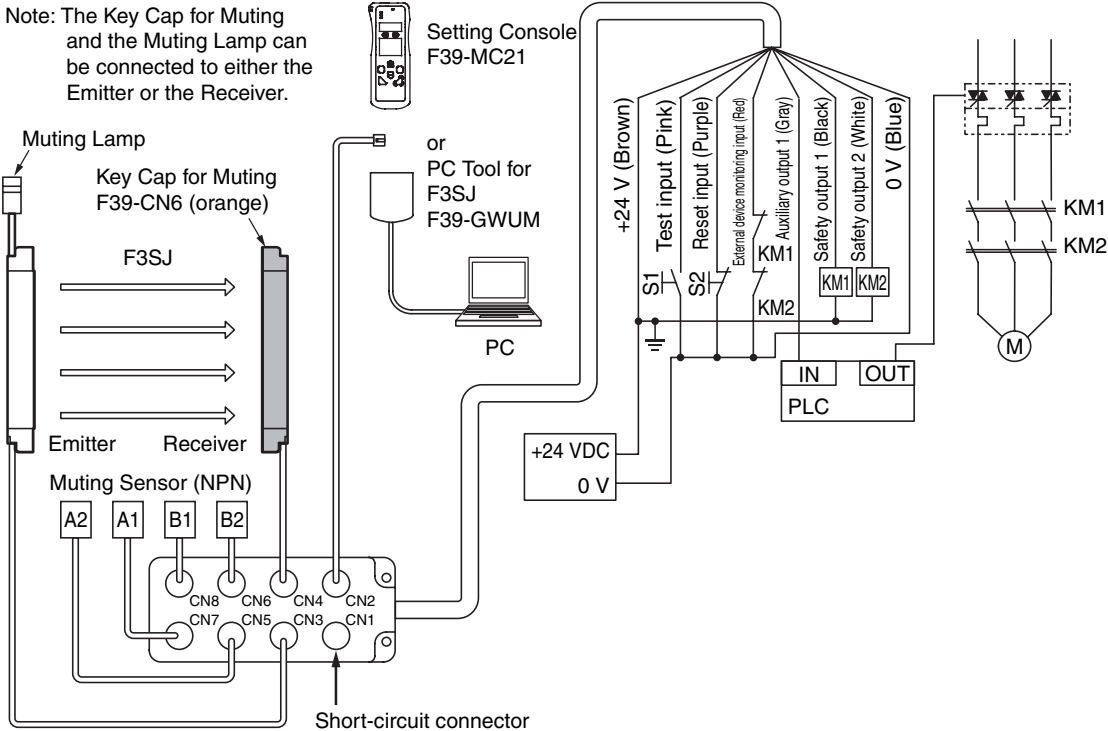

Model with Override Mode F39-TC5N02

Note: The Key Cap for Muting and the Muting Lamp can be connected to either the Emitter or the Receiver.

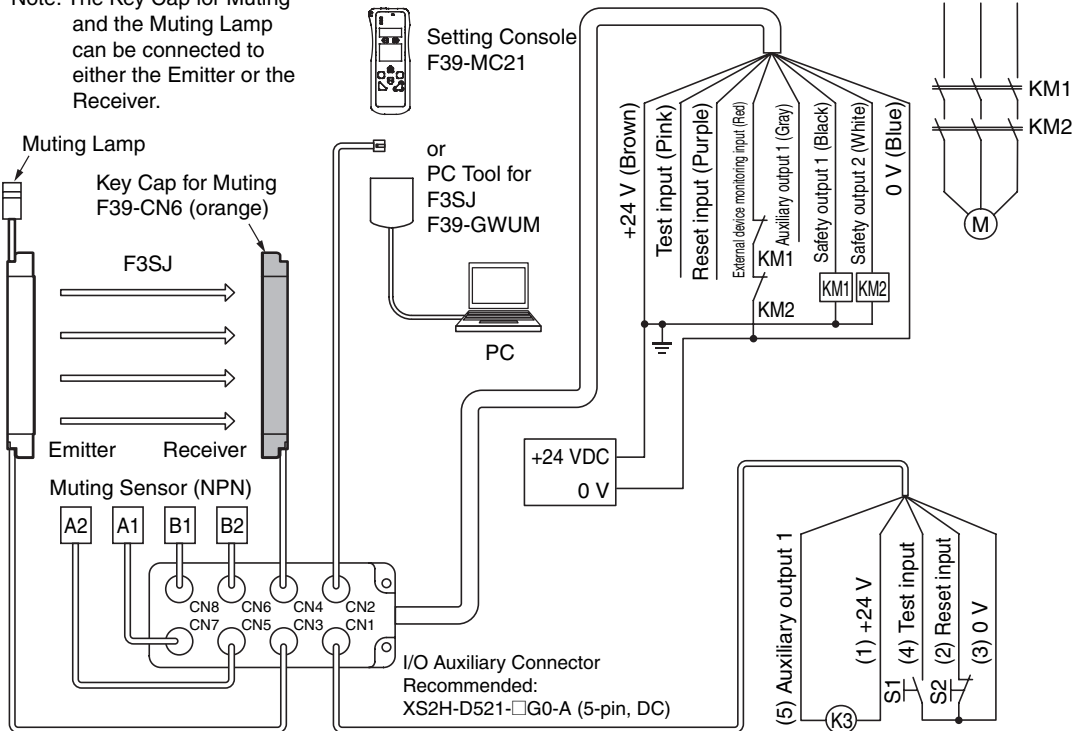

Dimensions

- F39-TC5P01
- F39-TC5P02
- F39-TC5N01
- F39-TC5N02

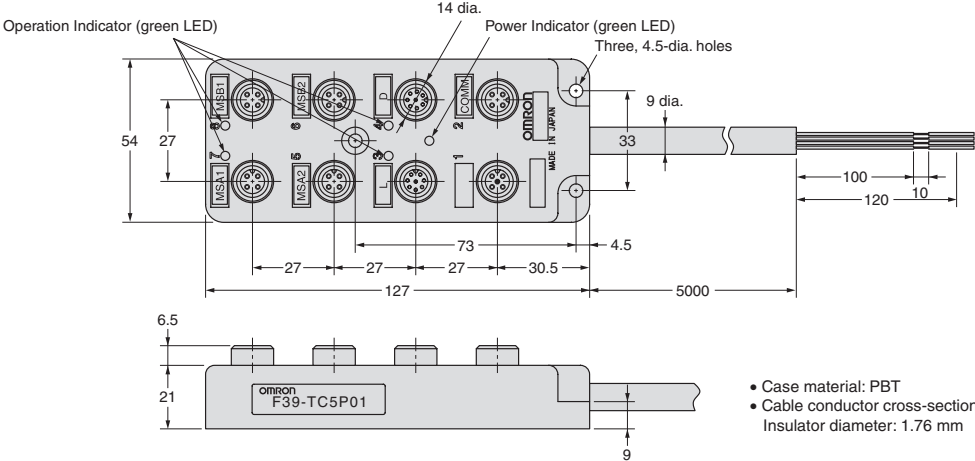

Safety Precautions

WARNING

The muting and override functions disable equipment safety functions. Use separate procedures to ensure safety when the muting and override functions are operating.

Position the Muting Sensors so that a distinction can be made between the entry of an object or a human. If the muting function were to operate when a human passed through, it may cause serious injury.

Install a Muting Lamp where it can be seen from all work locations, so that workers can check the status of the muting and override functions.

Muting times must be precisely set according to the application by qualified personnel who have received appropriate training. In particular, if the muting time limit is to be set to infinity, the person who makes the setting must bear responsibility.

Use two independent input devices for the muting inputs.

Install the F3SJ, Muting Sensors, or a protective wall so that workers cannot enter hazardous areas while muting is in effect, and set muting times.

Install override switches where they can be seen from the hazardous area, and where they cannot be operated from within the hazardous area. Before starting an override, check to make sure that nobody is within the hazardous area.

Precautions for Safe Use

Installation Conditions

- Connector tightening torque: 0.39 to 0.49 N·m
- Panel mounting tightening torque: 0.6 to 0.8 N·m
(use metric 4 screws)

Handling

- Make sure that the power is turned OFF before connecting or disconnecting the connector.
- Make sure that fasteners are tightened properly by hand. (0.39 to 0.49 N·m)
The use of pliers may cause damage. If the screws are not tightened properly, the degree of protection may not be obtained, and the screws may come loose from vibration.
- If the cables are connected with the polarity reversed, the load will not operate, or the operation indicator will not light.
- Make sure that signal lines are always connected through a load.
- Use Sensors that meet the specifications.
- Do not pull on the connectors and cables. Doing so may damage the connector or break the cable.
- To avoid breaking the cable and damaging the connector, install them in a location where there is no danger of stepping on them. If you must install them in a location where they might be stepped on, place a protective cover on them.
- When installing the product, do not bend the cable where it is connected to the product.
- If you must bend the cable, make sure that the bend radius is greater than 60 mm.
- If you are not going to install Sensors and switches, place waterproof covers (XS2Z-22) on the connectors to protect the contact surface.

Storage

Observe the following points when storing the product for an extended period of time.

1. Make sure that the storage location is well protected against dust and humidity.
2. Do not store the product close to areas where ammonia or sulfurization gas is generated.

Read and Understand This Catalog

Please read and understand this catalog before purchasing the products. Please consult your OMRON representative if you have any questions or comments.

Warranty and Limitations of Liability

WARRANTY

OMRON's exclusive warranty is that the products are free from defects in materials and workmanship for a period of one year (or other period if specified) from date of sale by OMRON.

OMRON MAKES NO WARRANTY OR REPRESENTATION, EXPRESS OR IMPLIED, REGARDING NON-INFRINGEMENT, MERCHANTABILITY, OR FITNESS FOR PARTICULAR PURPOSE OF THE PRODUCTS. ANY BUYER OR USER ACKNOWLEDGES THAT THE BUYER OR USER ALONE HAS DETERMINED THAT THE PRODUCTS WILL SUITABLY MEET THE REQUIREMENTS OF THEIR INTENDED USE. OMRON DISCLAIMS ALL OTHER WARRANTIES, EXPRESS OR IMPLIED.

LIMITATIONS OF LIABILITY

OMRON SHALL NOT BE RESPONSIBLE FOR SPECIAL, INDIRECT, OR CONSEQUENTIAL DAMAGES, LOSS OF PROFITS OR COMMERCIAL LOSS IN ANY WAY CONNECTED WITH THE PRODUCTS, WHETHER SUCH CLAIM IS BASED ON CONTRACT, WARRANTY, NEGLIGENCE, OR STRICT LIABILITY.

In no event shall the responsibility of OMRON for any act exceed the individual price of the product on which liability is asserted.

IN NO EVENT SHALL OMRON BE RESPONSIBLE FOR WARRANTY, REPAIR, OR OTHER CLAIMS REGARDING THE PRODUCTS UNLESS OMRON'S ANALYSIS CONFIRMS THAT THE PRODUCTS WERE PROPERLY HANDLED, STORED, INSTALLED, AND MAINTAINED AND NOT SUBJECT TO CONTAMINATION, ABUSE, MISUSE, OR INAPPROPRIATE MODIFICATION OR REPAIR.

Application Considerations

SUITABILITY FOR USE

OMRON shall not be responsible for conformity with any standards, codes, or regulations that apply to the combination of products in the customer's application or use of the products.

At the customer's request, OMRON will provide applicable third party certification documents identifying ratings and limitations of use that apply to the products. This information by itself is not sufficient for a complete determination of the suitability of the products in combination with the end product, machine, system, or other application or use.

The following are some examples of applications for which particular attention must be given. This is not intended to be an exhaustive list of all possible uses of the products, nor is it intended to imply that the uses listed may be suitable for the products:

- Outdoor use, uses involving potential chemical contamination or electrical interference, or conditions or uses not described in this catalog.
- Nuclear energy control systems, combustion systems, railroad systems, aviation systems, medical equipment, amusement machines, vehicles, safety equipment, and installations subject to separate industry or government regulations.
- Systems, machines, and equipment that could present a risk to life or property.

Please know and observe all prohibitions of use applicable to the products.

NEVER USE THE PRODUCTS FOR AN APPLICATION INVOLVING SERIOUS RISK TO LIFE OR PROPERTY WITHOUT ENSURING THAT THE SYSTEM AS A WHOLE HAS BEEN DESIGNED TO ADDRESS THE RISKS, AND THAT THE OMRON PRODUCTS ARE PROPERLY RATED AND INSTALLED FOR THE INTENDED USE WITHIN THE OVERALL EQUIPMENT OR SYSTEM.

PROGRAMMABLE PRODUCTS

OMRON shall not be responsible for the user's programming of a programmable product, or any consequence thereof.

Disclaimers

CHANGE IN SPECIFICATIONS

Product specifications and accessories may be changed at any time based on improvements and other reasons.

It is our practice to change model numbers when published ratings or features are changed, or when significant construction changes are made. However, some specifications of the products may be changed without any notice. When in doubt, special model numbers may be assigned to fix or establish key specifications for your application on your request. Please consult with your OMRON representative at any time to confirm actual specifications of purchased products.

DIMENSIONS AND WEIGHTS

Dimensions and weights are nominal and are not to be used for manufacturing purposes, even when tolerances are shown.

PERFORMANCE DATA

Performance data given in this catalog is provided as a guide for the user in determining suitability and does not constitute a warranty. It may represent the result of OMRON's test conditions, and the users must correlate it to actual application requirements. Actual performance is subject to the OMRON Warranty and Limitations of Liability.

ERRORS AND OMISSIONS

The information in this document has been carefully checked and is believed to be accurate; however, no responsibility is assumed for clerical, typographical, or proofreading errors, or omissions.

2009.9

In the interest of product improvement, specifications are subject to change without notice.

OMRON Corporation
Industrial Automation Company

<http://www.ia.omron.com/>

(c)Copyright OMRON Corporation 2009 All Right Reserved.