

Basic I/O Selection

This section describes the standard and high-density input and output modules, terminal blocks and cables used in a CJ1 system.

Input Configuration

What input voltage do you need?

Type	DC Inputs	AC Inputs
Model number	CJ1W-ID2□□□ CJ1W-MD□□□□	CJ1W-IA□□□□
See page	B-37, B-54	B-37

How many input points are required?

Choose from the available point densities below.

Input Points	8	16	32	64
DC inputs	CJ1W-ID201	CJ1W-ID211	CJ1W-ID231 CJ1W-ID232 CJ1W-MD231 CJ1W-MD232 CJ1W-MD233	CJ1W-ID261 CJ1W-ID262 CJ1W-MD261 CJ1W-MD263 CJ1W-MD563
AC inputs	CJ1W-IA201	CJ1W-IA111	–	–
See page	B-37	B-37	B-37, B-54	B-37, B-54

What are the input current requirements?

Input Current	3.5 mA or Below	4.1 mA or Below	7 mA or Below	9 mA or Below	10 mA or Below
DC inputs	CJ1W-MD563	CJ1W-ID231 CJ1W-ID232 CJ1W-ID261 CJ1W-ID262 CJ1W-MD261 CJ1W-MD263	CJ1W-ID211 CJ1W-MD231 CJ1W-MD232 CJ1W-MD233	–	CJ1W-ID201
AC inputs	–	–	CJ1W-IA111	CJ1W-IA201	–
See page	B-54	B-37, B-54	B-37, B-54	B-37	B-37

Are terminal blocks and connection cables necessary?

Input modules with 8 or 16 points have built-in terminal strips that accept direct wiring from input devices. High-density 32- and 64-point modules use cables and terminal blocks to connect inputs and consolidate wiring back to the control panel. For more information, see pages B-37 to B-38.

Module	Connector Type	Terminal Block	Cable
CJ1W-IA111 CJ1W-IA201 CJ1W-ID211	Removable screw terminal strip	Not required	Not required
CJ1W-ID231 CJ1W-MD231 CJ1W-ID261 CJ1W-MD261	Fujitsu connector on module	XW2B-40G4 or XW2B-40G5 Two XW2B-40G4 or XW2B-40G5	XW2Z-□□□B Two XW2Z-□□□B
CJ1W-ID232 CJ1W-MD233 CJ1W-ID262 CJ1W-MD263 CJ1W-MD563	MIL-type flat ribbon connector on module	XW2B-40G4 or XW2B-40G5 Two XW2B-40G4 or XW2B-40G5	XW2Z-□□□K Two XW2Z-□□□K

Note: For more information on wiring connections, please refer to the wiring section starting on page D-1.

Output Configuration

How many output points are required?

Choose from the available point densities below.

Output Points	8	16	32	64	See page
Transistor	CJ1W-OD20□	CJ1W-OD21□	CJ1W-OD23□	CJ1W-OD26□	B-44
			CJ1W-MD23□	CJ1W-MD26□	B-54
Relay	CJ1W-OC201	CJ1W-OC211	–	–	B-44
Triac	CJ1W-OA201	–	–	–	B-44
TTL	–	–	–	CJ1W-MD563	B-54

If transistor output, do you need sinking (NPN) or sourcing (PNP) outputs?

Output Points	8	16	32	64	See page
Sinking outputs	CJ1W-OD201	CJ1W-OD211	CJ1W-OD231	CJ1W-OD261	B-44
	CJ1W-OD203		CJ1W-OD233	CJ1W-OD263	B-44
			CJ1W-MD231	CJ1W-MD261	B-54
			CJ1W-MD233	CJ1W-MD263	B-54
Sourcing outputs	CJ1W-OD202	CJ1W-OD212	CJ1W-OD232	CJ1W-OD262	B-44
	CJ1W-OD204				B-44

Are terminal blocks and connection cables necessary?

Output modules with 8 or 16 points have built-in terminal strips that accept direct wiring from output devices. High-density 32- and 64-point modules use cables and terminal blocks to connect outputs and consolidate wiring back to the control panel. For more information, see pages B-45 to B-46.

Module	Connector Type	Terminal Block	Cable
CJ1W-OC201	Removable screw terminal strip	Not required	Not required
CJ1W-OC211			
CJ1W-OD20□			
CJ1W-OD21□			
CJ1W-OD231	Fujitsu connector on module	XW2B-40G4 or XW2B-40G5	XW2Z-□□□B
CJ1W-MD231			
CJ1W-OD261			
CJ1W-MD261	Two XW2B-40G4 or XW2B-40G5	Two XW2Z-□□□B	
CJ1W-OD232	MIL-type flat ribbon connector on module	XW2B-40G4 or XW2B-40G5	XW2Z-□□□K
CJ1W-MD233			
CJ1W-OD262			
CJ1W-MD263			
CJ1W-OD263			
CJ1W-MD563	Two XW2B-40G4 or XW2B-40G5	Two XW2Z-□□□K	

Note: For more information on wiring connections, please refer to the wiring section starting on page D-1.

Configuration Guidelines

Remember to add all the current consumptions of basic I/O and special I/O modules, and CPU bus units to determine which power supply is appropriate.

If there are more than 10 modules involved or the current consumption exceeds the capability of the available power supplies, go to page B-109 in the *System Power and Expansion* section for configuration of I/O expansion racks.

For more I/O options, see the *Industrial Networking* section for DeviceNet I/O on page B-88 and CompoBus/S I/O on page B-97.

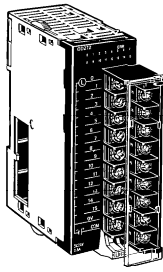

Input Modules (8/16 points)
CJ1W-ID201
CJ1W-ID211
CJ1W-IA□□□

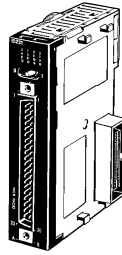

Input Modules (32 points)
CJ1W-ID23□

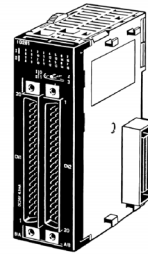

Input Modules (64 points)
CJ1W-ID26□

■ DC Input Modules

Classification	Input voltage	Inputs	Connector type	Input current	Model
Basic I/O Module	12-24 VDC	8 pts	Removable terminal block	10 mA	CJ1W-ID201
	24 VDC	16 pts	Removable terminal block	7 mA	CJ1W-ID211
		32 pts	Fujitsu-compatible connector	4.1 mA	CJ1W-ID231
		32 pts	MIL connector	4.1 mA	CJ1W-ID232
		64 pts	Fujitsu-compatible connector	4.1 mA	CJ1W-ID261
		64 pts	MIL connector	4.1 mA	CJ1W-ID262

■ AC Input Modules

Classification	Input voltage	Inputs	Connector type	Input current	Model
Basic I/O Module	100 to 120 VAC	16 pts	Removable terminal block	7 mA (100 V, 50 Hz)	CJ1W-IA111
	200 to 240 VAC	8 pts		9 mA (200 V, 50 Hz)	CJ1W-IA201

■ Wiring and Cabling Examples

32-Point Input Modules
CJ1W-ID23□

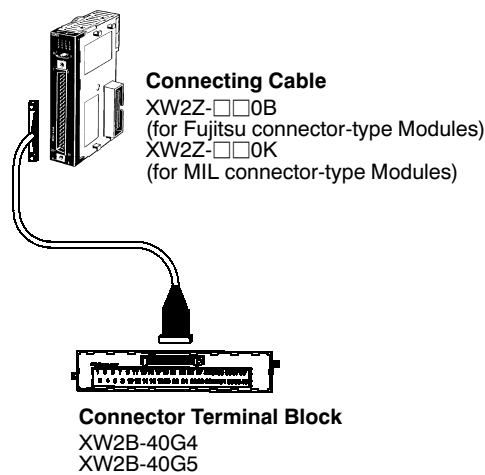

64-Point Input Modules
CJ1W-ID26□

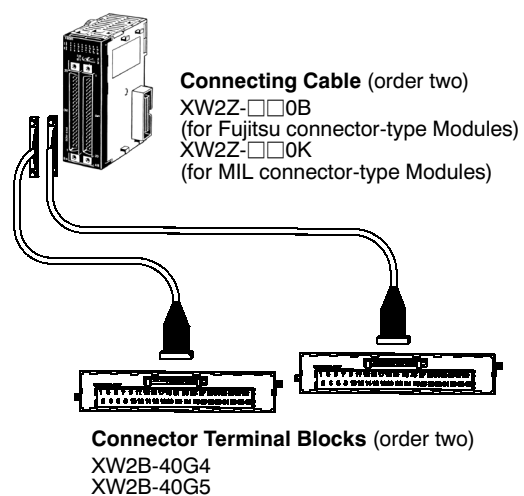

Additional Information: For more details and specifications on cables and terminal blocks, refer to manual No. W393 or check the Wiring Solutions section of this catalog for more options.

Input Modules

Wiring and Cabling Examples (continued)

8-Point and 16-Point Input Modules (Optional)

CJ1W-ID211, CJ1W-IA□□1, and CJ1W-ID201

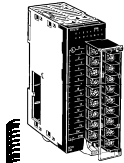

Note: Since the 8- and 16-point I/O Modules have integrated screw terminals, this wiring configuration is necessary only if you are connecting to Omron XW2B Terminal Blocks.

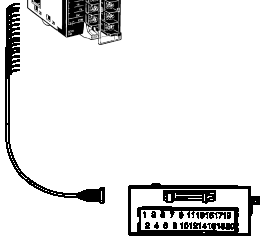

Connector Terminal Blocks
XW2B-20G4
XW2B-20G5

Connecting Cable

XW2Z-□□0F

(cable terminated with crimp hooks)

Input Module Circuit Configuration and Terminal Arrangement

CJ1W-ID201

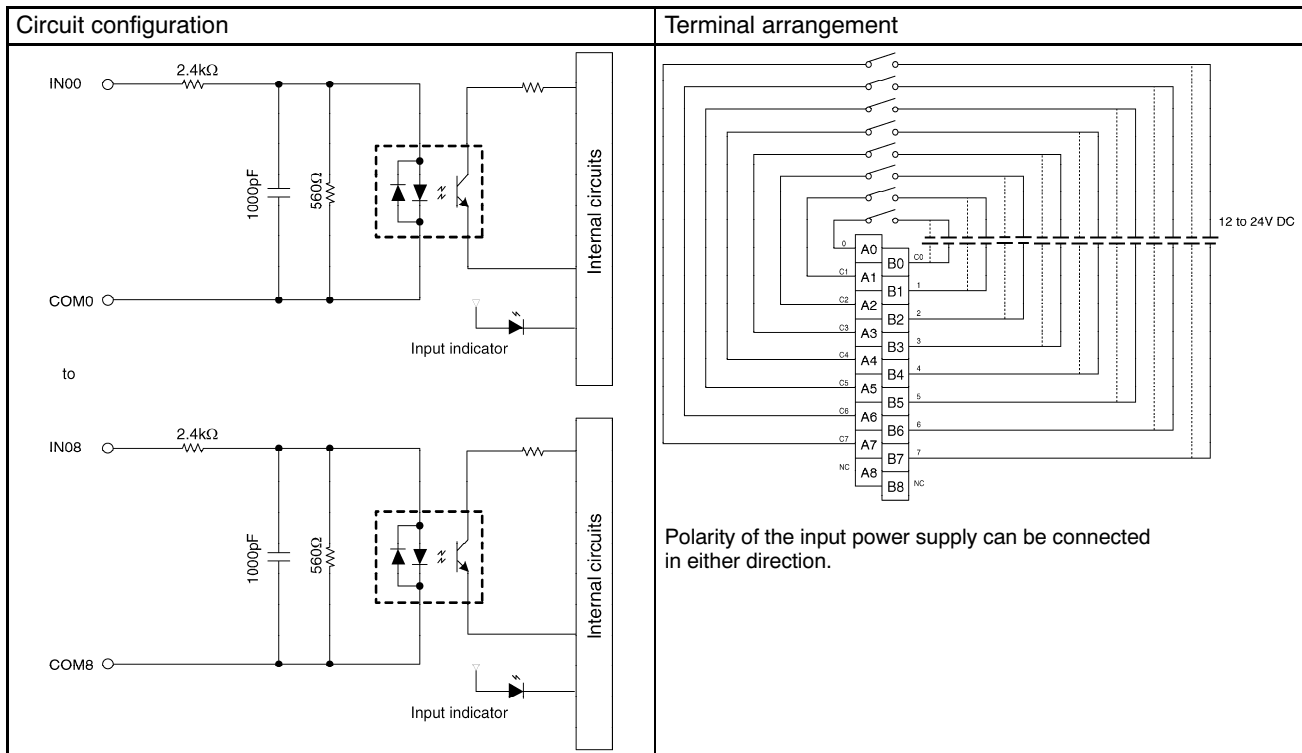

Input Module Circuit Configuration and Terminal Arrangement (continued)

CJ1W-ID211

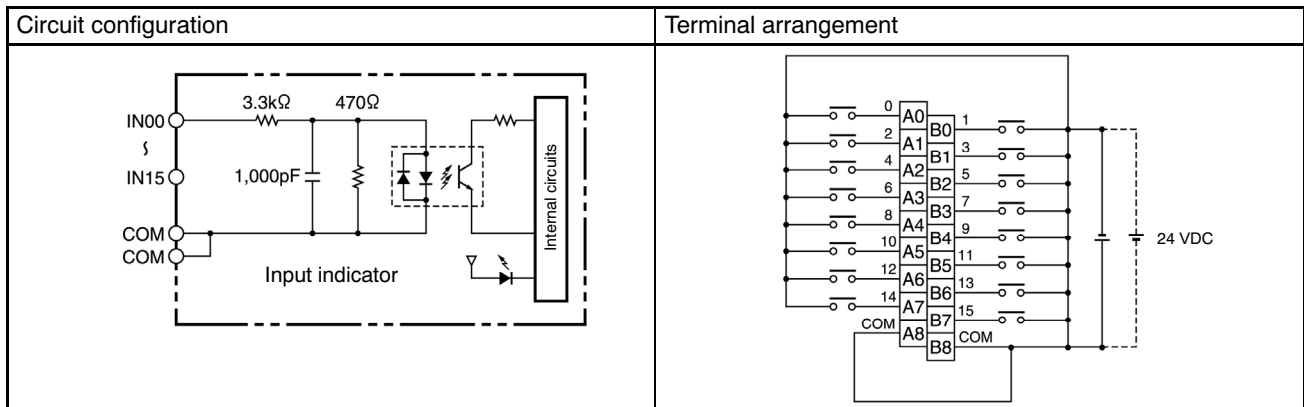

CJ1W-ID231

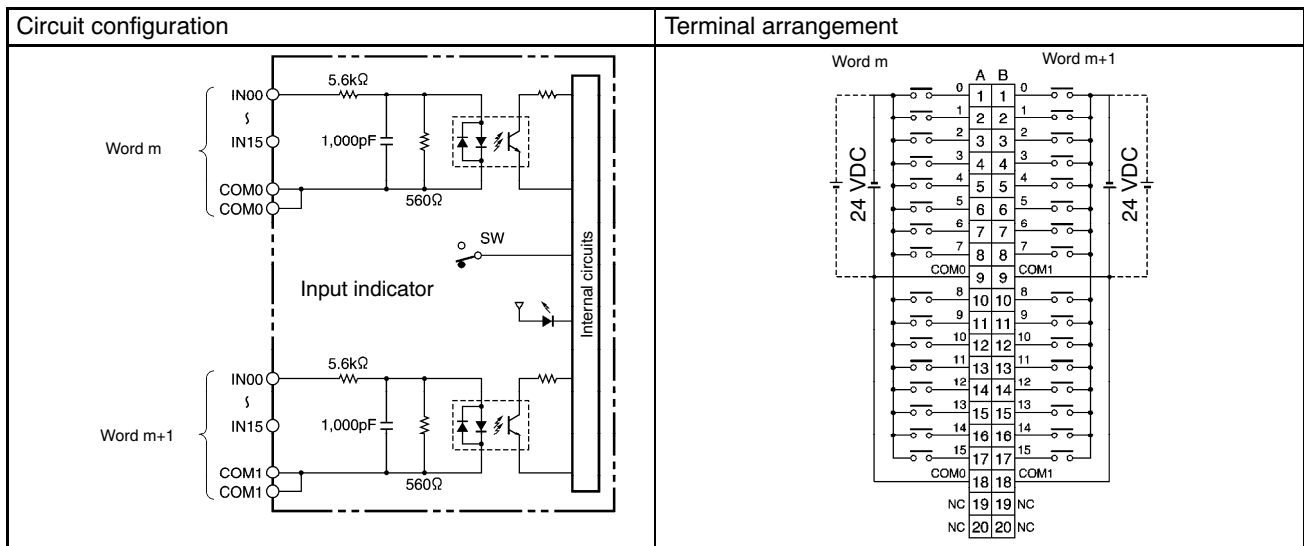

Input Modules

Input Module Circuit Configuration and Terminal Arrangement (continued)

CJ1W-ID232

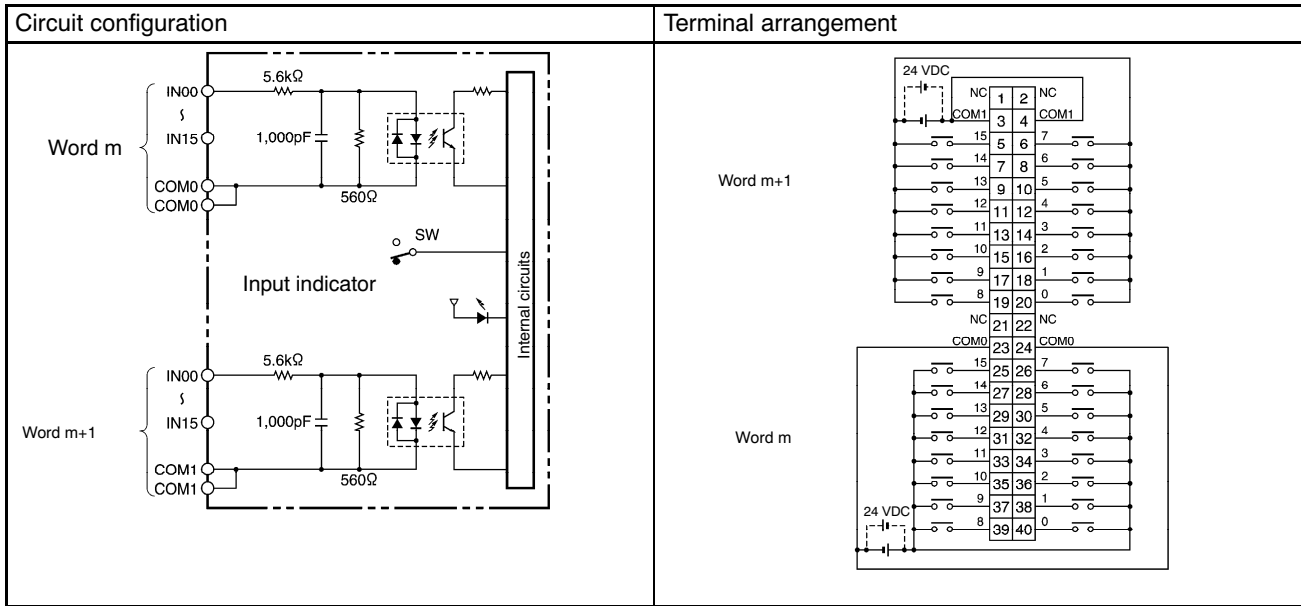

CJ1W-ID261

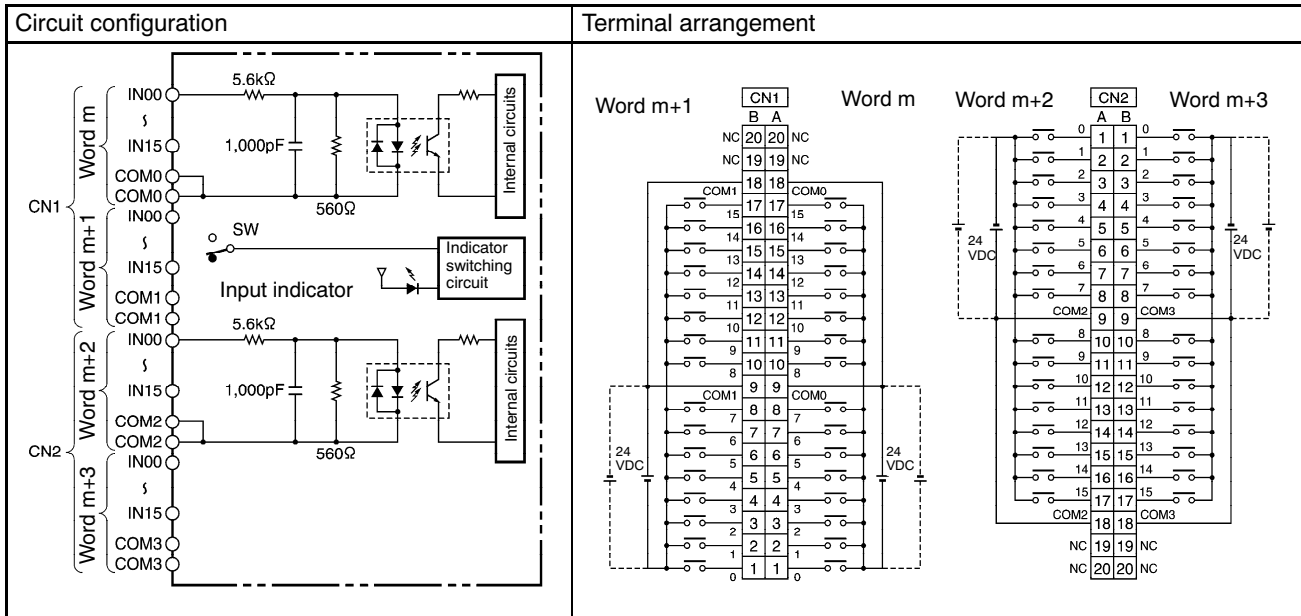

Input Module Circuit Configuration and Terminal Arrangement (continued)

CJ1W-ID262

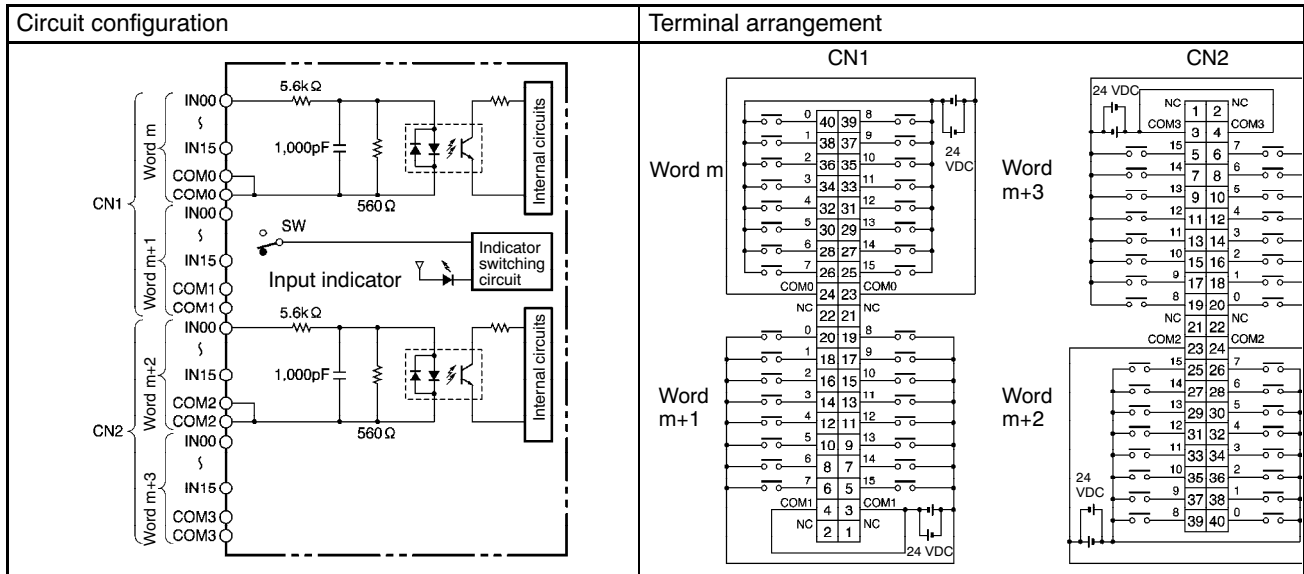

CJ1W-IA111

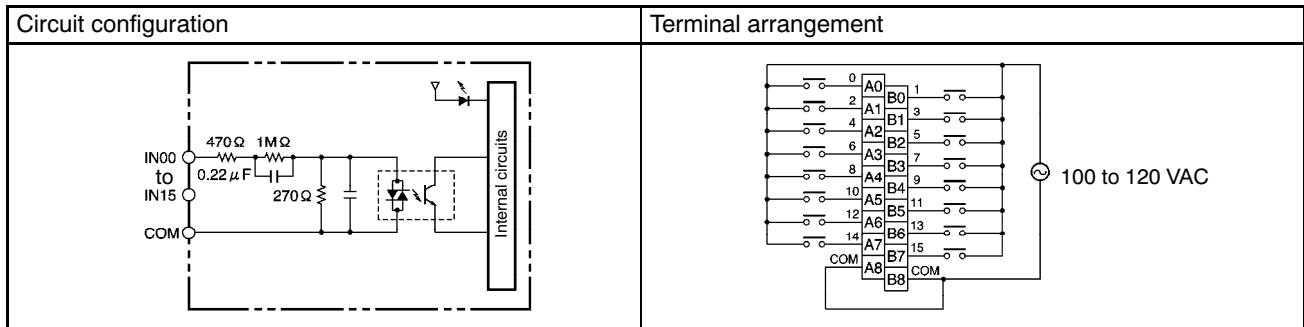

CJ1W-IA201

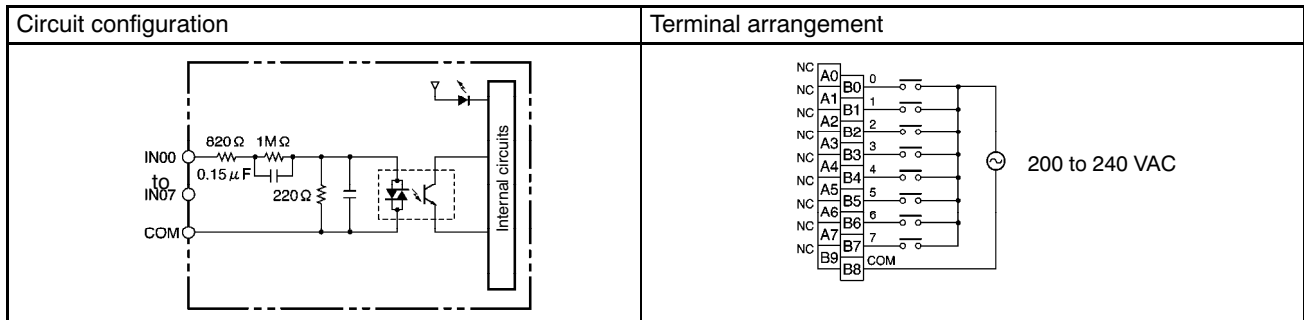

Interrupt Input Module

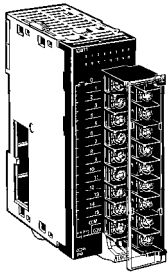

CJ1W-INT01

System Configuration

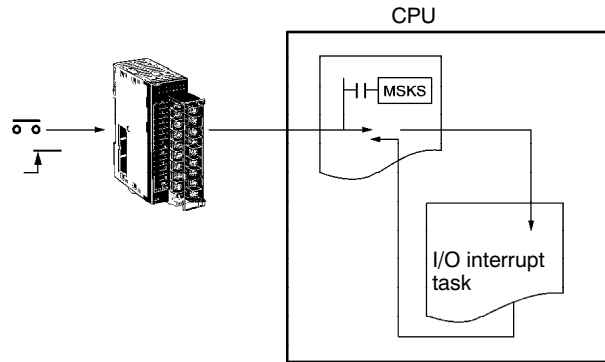

Features

- High-speed response for interrupt task execution: 0.37 ms OFF to ON and 0.82 ms ON to OFF.
- When an input on the Interrupt Input Module turns ON, the CPU is notified immediately, cyclic task execution is interrupted, and an I/O interrupt task is executed.

Specifications

Module	Model	Input voltage	Inputs	Input signal pulse width	No. of mountable modules	Mounting location	External connections
Interrupt Input Module	CJ1W-INT01	24 VDC	16 inputs	ON: 0.05 ms min. OFF: 0.5 ms min.	2 max.	Any of the 5 slots next to the CPU on the CPU Rack.	Removable terminal block

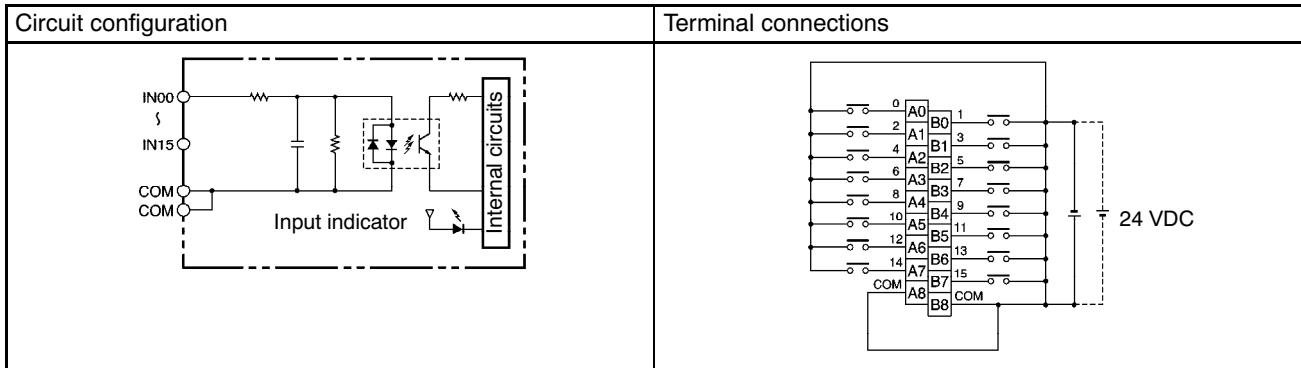

Additional Information: For more details and specifications on any of these modules, refer to manual No. W393.

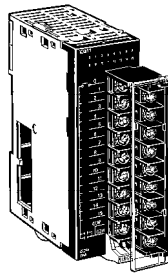

CJ1W-IDP01

■ Features

- With a high-speed Pulse-Catch Module, pulse inputs shorter than the cycle time of the CPU can be read.
- Input data in the internal circuits is cleared during the input refresh period.

■ Specifications

Module	Model	Input voltage	Inputs	Input signal pulse width	No. of mountable modules	Mounting location	External connections
Pulse Catch Input Module	CJ1W-IDP01	24 VDC	16 inputs	ON: 0.01 ms min. OFF: 0.5 ms min.	No limit	Any location on CPU Rack or Expansion Rack	Removable terminal block

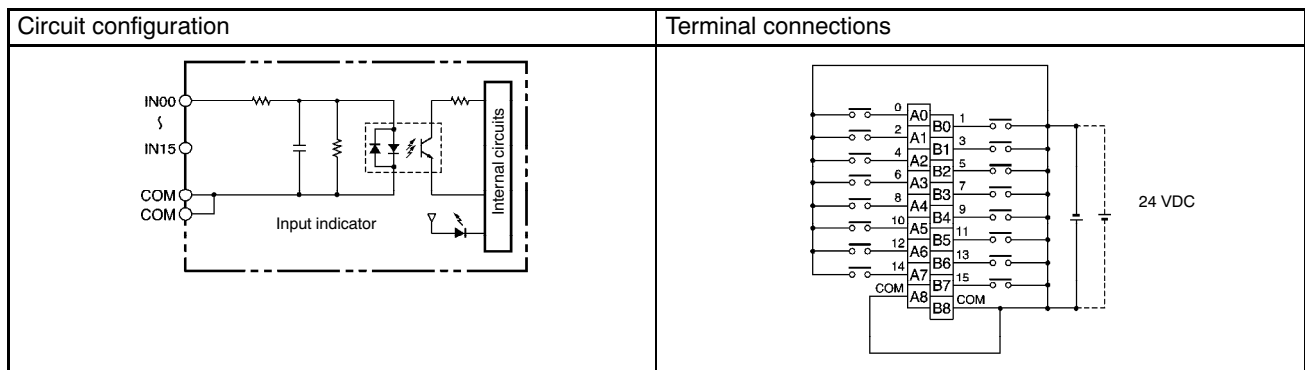

Additional Information: For more details and specifications on any of these modules, refer to manual No. W393.

Output Modules

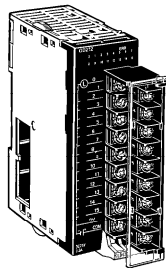

**Output Modules
(8/16 points)**
 CJ1W-OD20□
 CJ1W-OD21□
 CJ1W-OC2□1
 CJ1W-OA201

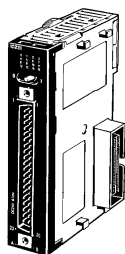

**Output Modules
(32 points)**
 CJ1W-OD23□

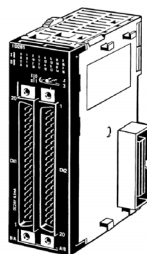

**Output Modules
(64 points)**
 CJ1W-OD26□

■ Relay Contact Output Modules

Classification	Outputs	Maximum switching capacity	Connections	Model
Basic I/O Module	8 pts (independent contacts)	2 A, 250 VAC/24 VDC	Removable terminal block	CJ1W-OC201
	16 pts			CJ1W-OC211

■ Transistor Output Modules

Classification	Outputs	Maximum switching capacity	Connections	Model
Basic I/O Module	8 pts	12 to 24 VDC, 2 A/pt, 8 A/module, sinking	Removable terminal block	CJ1W-OD201
		24 VDC, 2 A/pt, 8 A/module, sourcing, load short protection, disconnection detection, alarm		CJ1W-OD202
		12 to 24 VDC, 0.5 A/pt, 4 A/module, sinking		CJ1W-OD203
		24 VDC, 0.5 A/pt, 4 A/module, sourcing		CJ1W-OD204
	16 pts	12 to 24 VDC, 0.5 A/pt, 5 A/module, sinking	Removable terminal block	CJ1W-OD211
		24 VDC, 0.5 A/pt, 5 A/module sourcing, load short protection, alarm		CJ1W-OD212
	32 pts	12 to 24 VDC, 0.5 A/pt, 4 A/module, sinking	Fujitsu-compatible connector	CJ1W-OD231
		24 VDC, 0.5 A/pt, 4 A/module, sourcing, load short protection, alarm	MIL connector	CJ1W-OD232
		12 to 24 VDC, 0.5 A/pt, 4 A/module, sinking		CJ1W-OD233
	64 pts	12 to 24 VDC, 0.3 A/pt, 6.4 A/module, sinking	Fujitsu-compatible connector	CJ1W-OD261
		12 to 24 VDC, 0.3 A/pt, 6.4 A/module, sinking	MIL connector	CJ1W-OD262
		12 to 24 VDC, 0.3 A/pt, 6.4 A/module, sinking		CJ1W-OD263

■ Triac Output Modules

Classification	Outputs	Maximum switching capacity	Connections	Model
Basic I/O Module	8 pts	250 VAC, 0.6 A, 50/60 Hz	Removable terminal block	CJ1W-OA201

Additional Information: For more details and specifications on any of these modules, refer to manual No. W393.

■ Wiring and Cabling Examples

32-Point Output Modules

CJ1W-OD23□

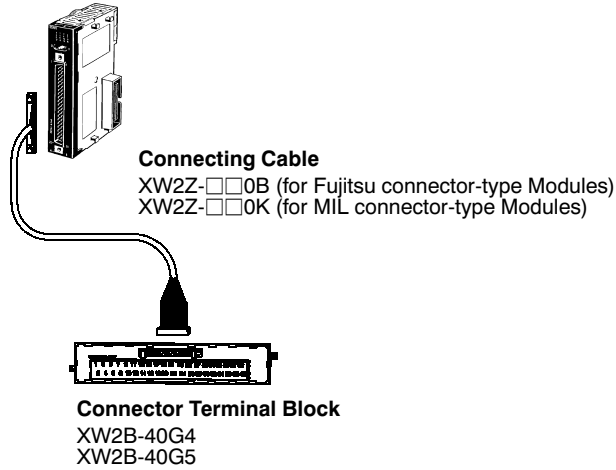

64-Point Output Modules

CJ1W-OD26□

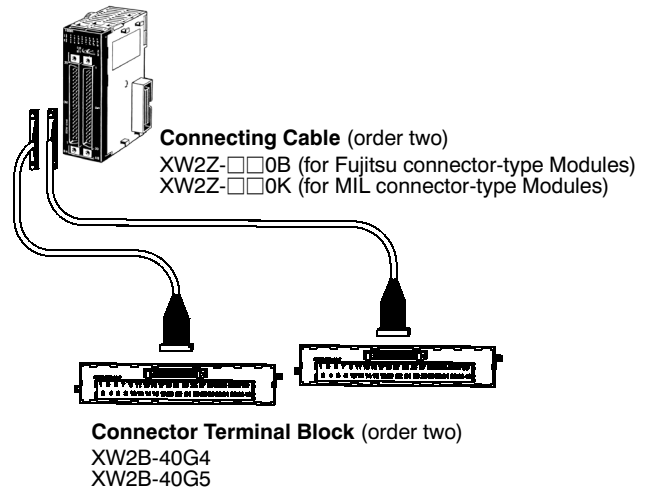

8-Point and 16-Point Output Modules (Optional)

CJ1W-OD20□ and CJ1W-OD21□, CJ1W-OA201, CJ1W-OC2□1

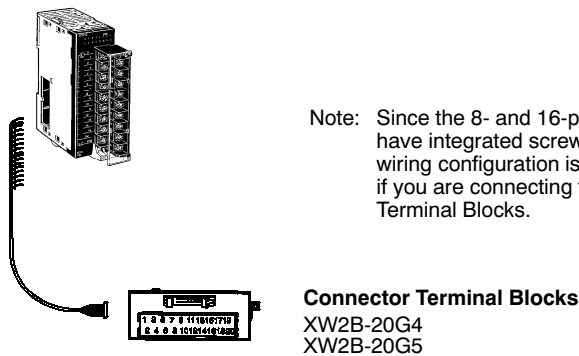

Note: Since the 8- and 16-point I/O Modules have integrated screw terminals, this wiring configuration is necessary only if you are connecting to Omron XW2B Terminal Blocks.

Connecting Cable

XW2Z-□□0F
 (cable terminated with crimp hooks)

(Wiring and Cabling Examples continue on the next page.)

Additional Information: For more details and specifications on cables and terminal blocks, refer to Manual No. W393 or check the Wiring Solutions section of this catalog for more options.

Output Modules

Wiring and Cabling Examples for Relay Outputs

32-Point Output Modules

CJ1W-OD23□

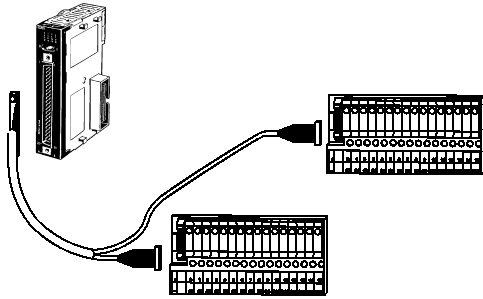

Relay Terminal Block
(Order two)
OPTIONS:
G7TC-OC16
or G70D-SOC16
or G70D-FOM16
or G70D-VSOC16
or G70D-VFOM16

Connecting Cable

G79-O□C-□ (for Fujitsu connector-type Modules)
G79-O□C-□-D1 (for MIL connector-type Modules)

64-Point Output Modules

CJ1W-OD26□

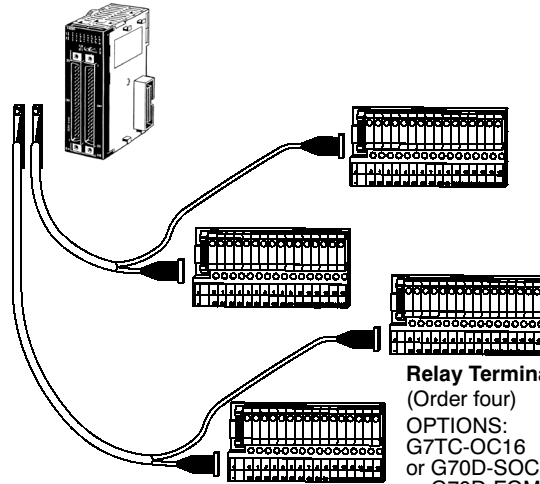

Relay Terminal Block
(Order four)
OPTIONS:
G7TC-OC16
or G70D-SOC16
or G70D-FOM16
or G70D-VSOC16
or G70D-VFOM16

Connecting Cable

(Order two)
G79-O□C-□ (for Fujitsu connector-type Modules)
G79-O□C-□-D1 (for MIL connector-type Modules)

Relay Output Module Circuit Configuration and Terminal Arrangement

CJ1W-OC201

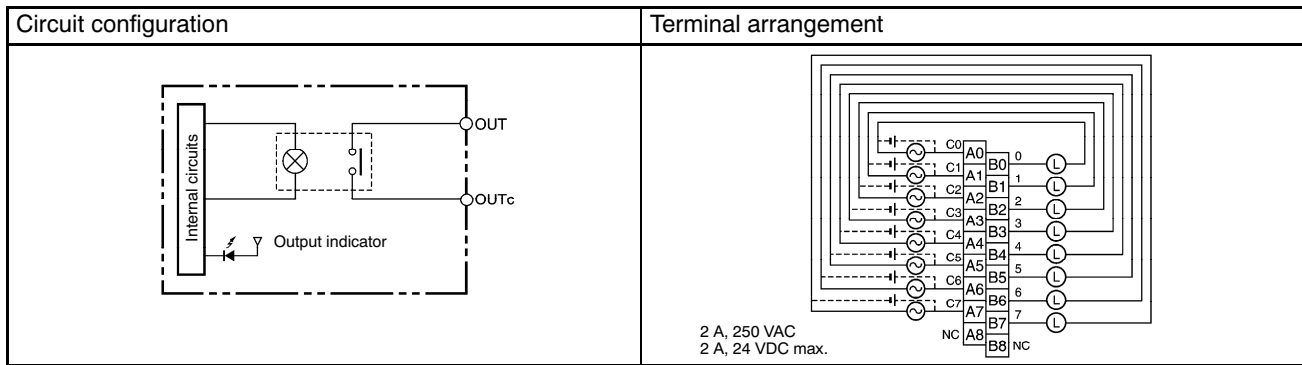

CJ1W-OC211

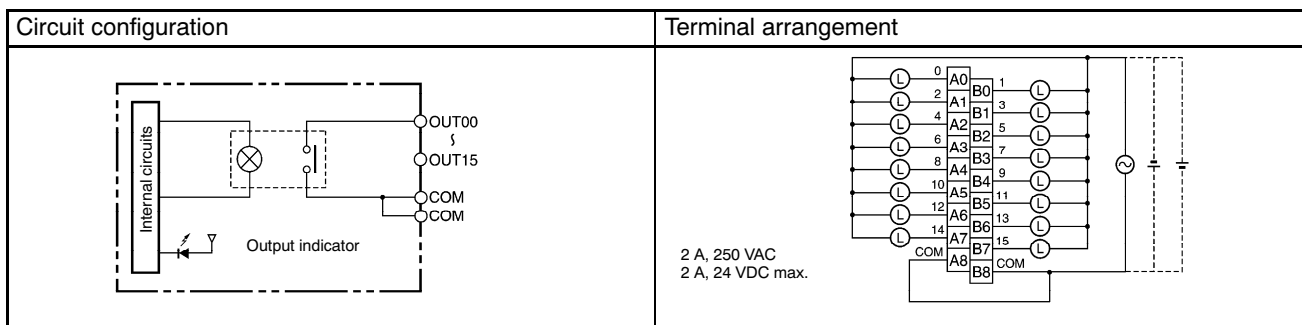

■ Transistor Output Module Circuit Configuration and Terminal Arrangement

CJ1W-OD201

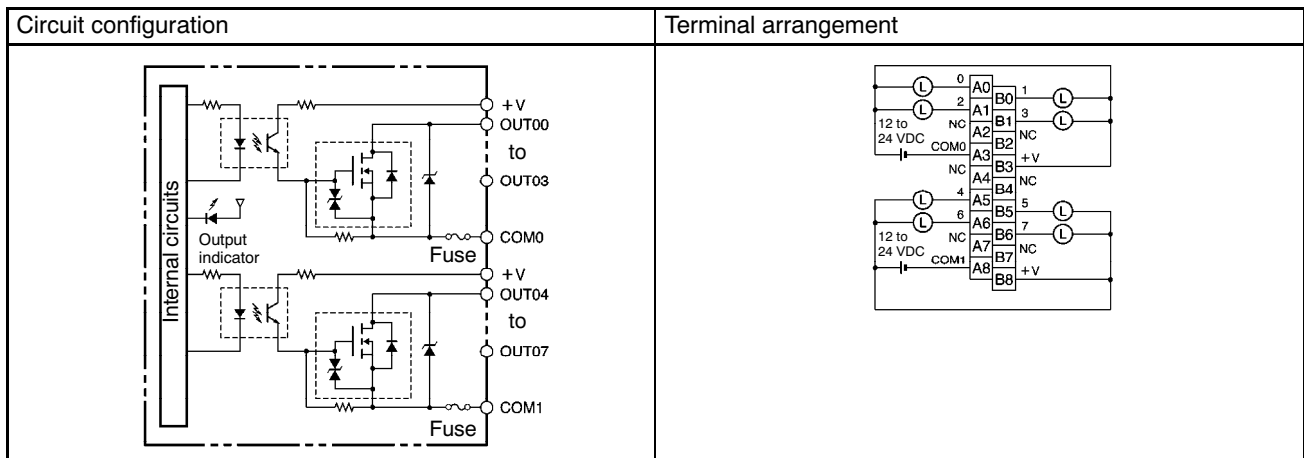

CJ1W-OD202

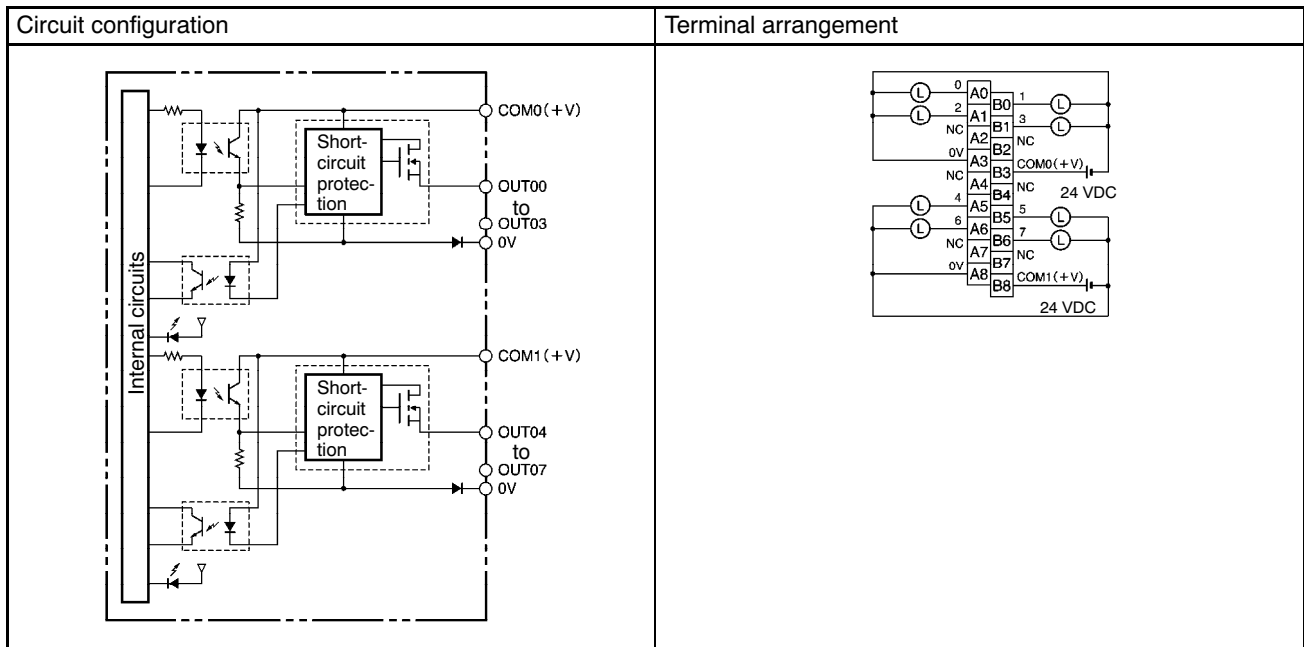

Output Modules

Transistor Output Module Circuit Configuration and Terminal Arrangement (continued)

CJ1W-OD203

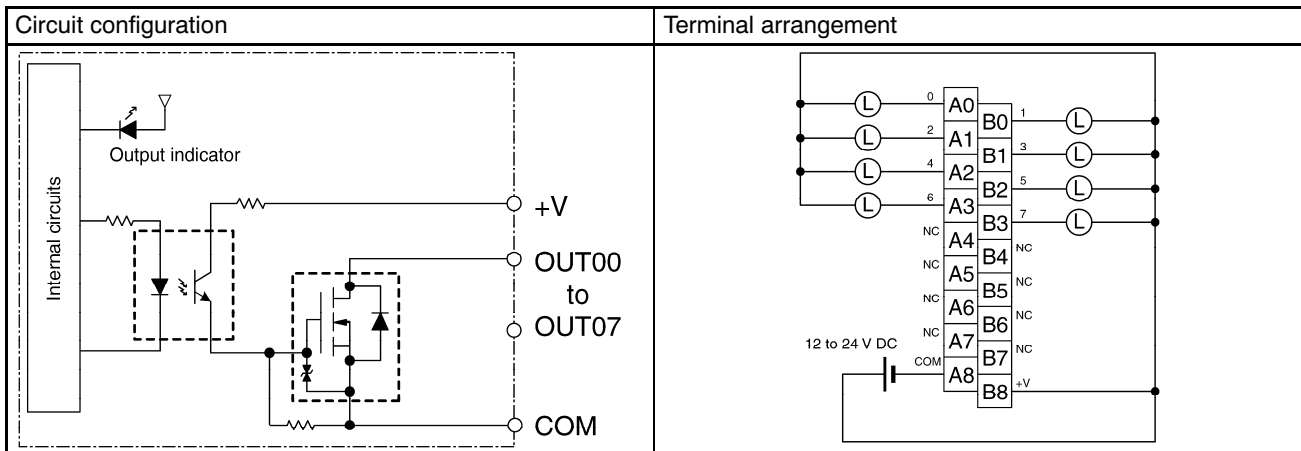

CJ1W-OD204

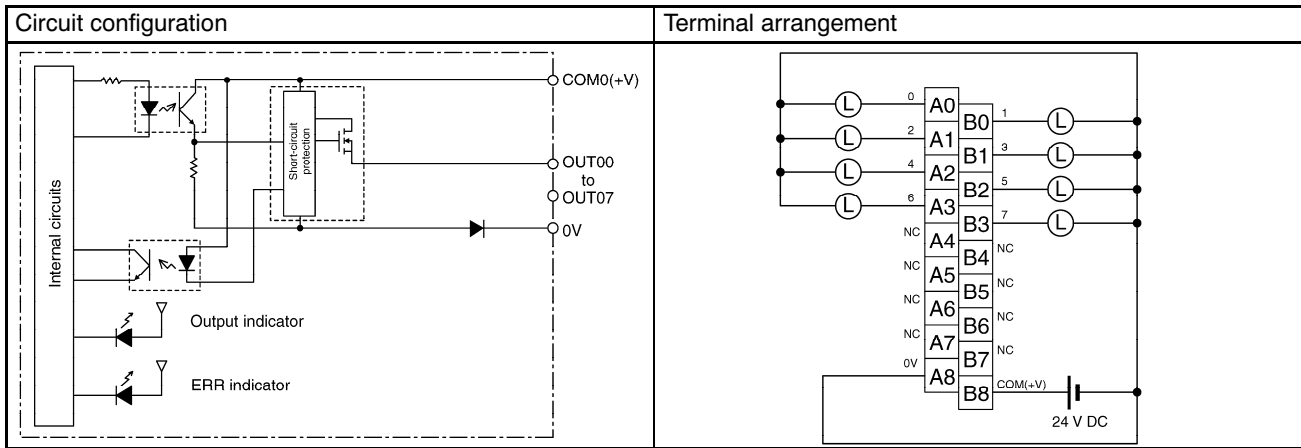

CJ1W-OD211

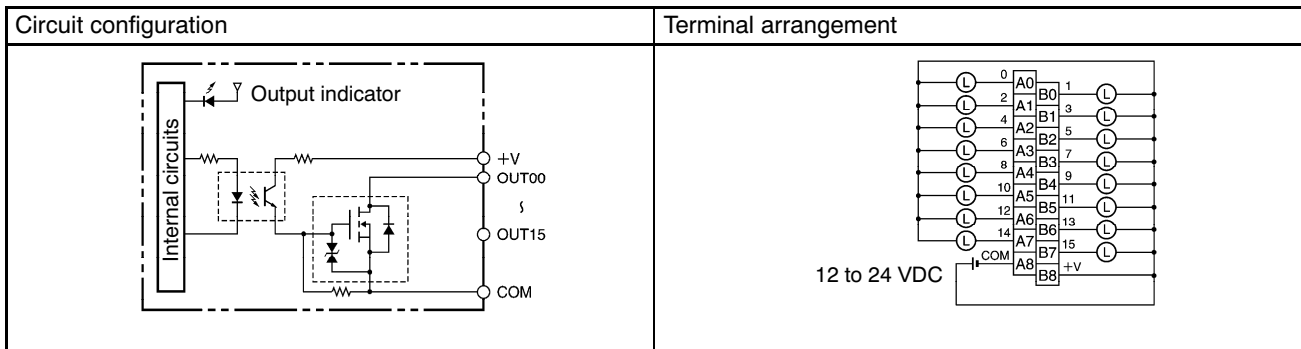

Transistor Output Module Circuit Configuration and Terminal Arrangement (continued)

CJ1W-OD212

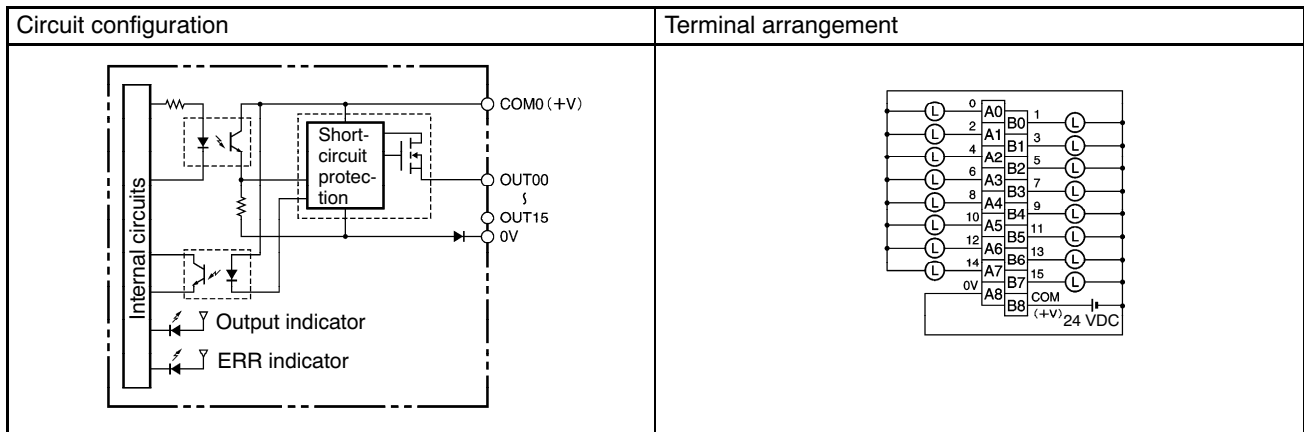

CJ1W-OD231

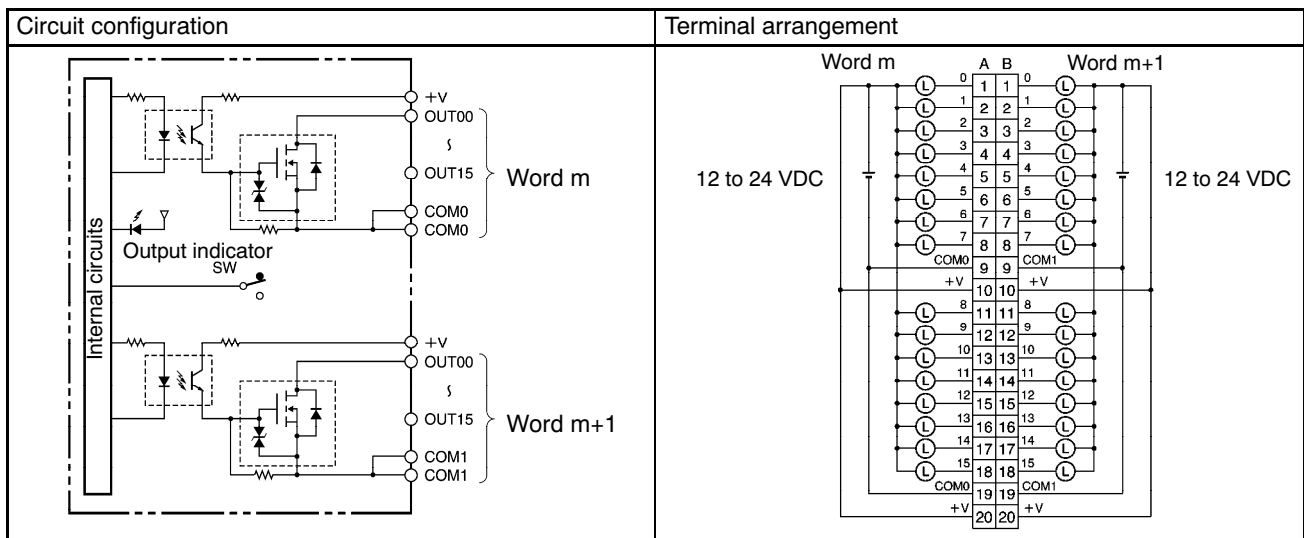

Output Modules

Transistor Output Module Circuit Configuration and Terminal Arrangement (continued)

CJ1W-OD232

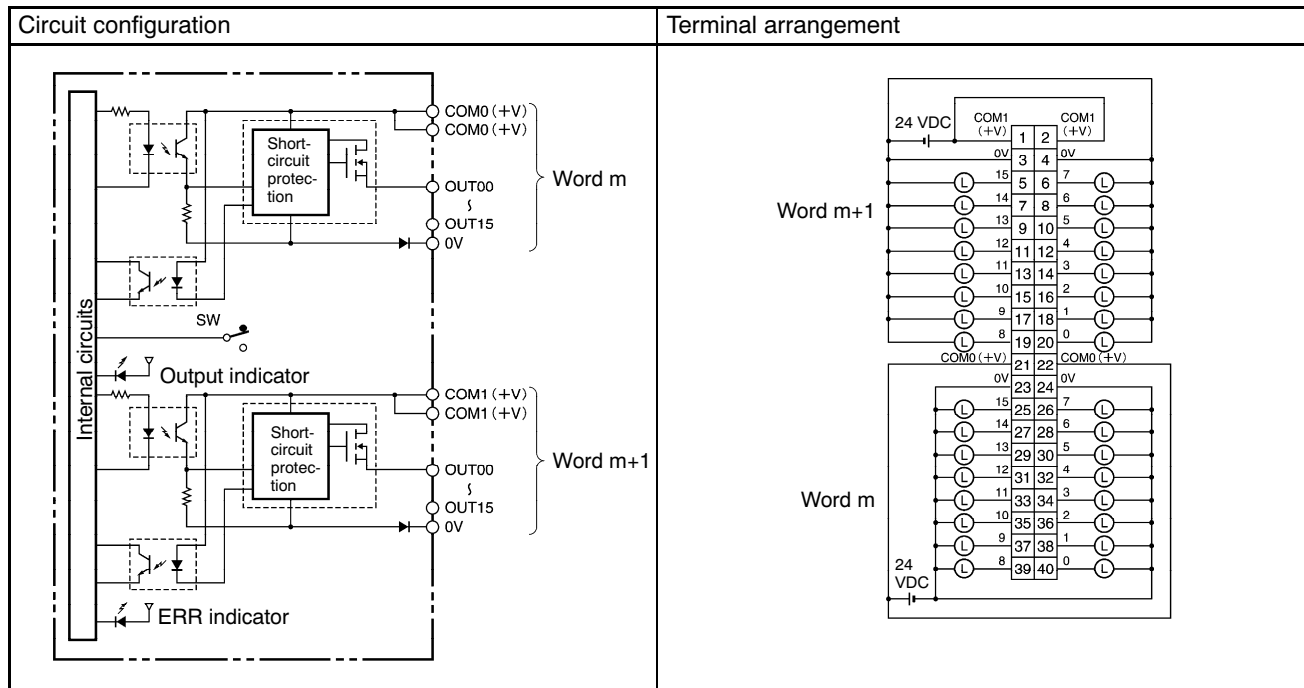

CJ1W-OD233

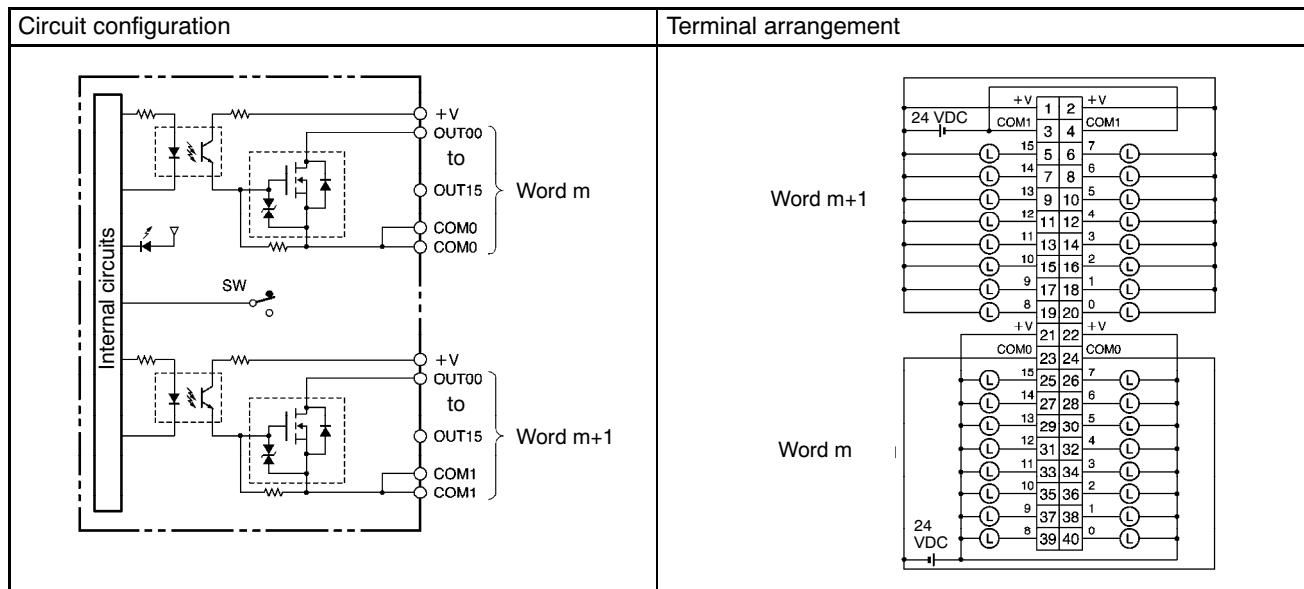

Transistor Output Module Circuit Configuration and Terminal Arrangement (continued)

CJ1W-OD261

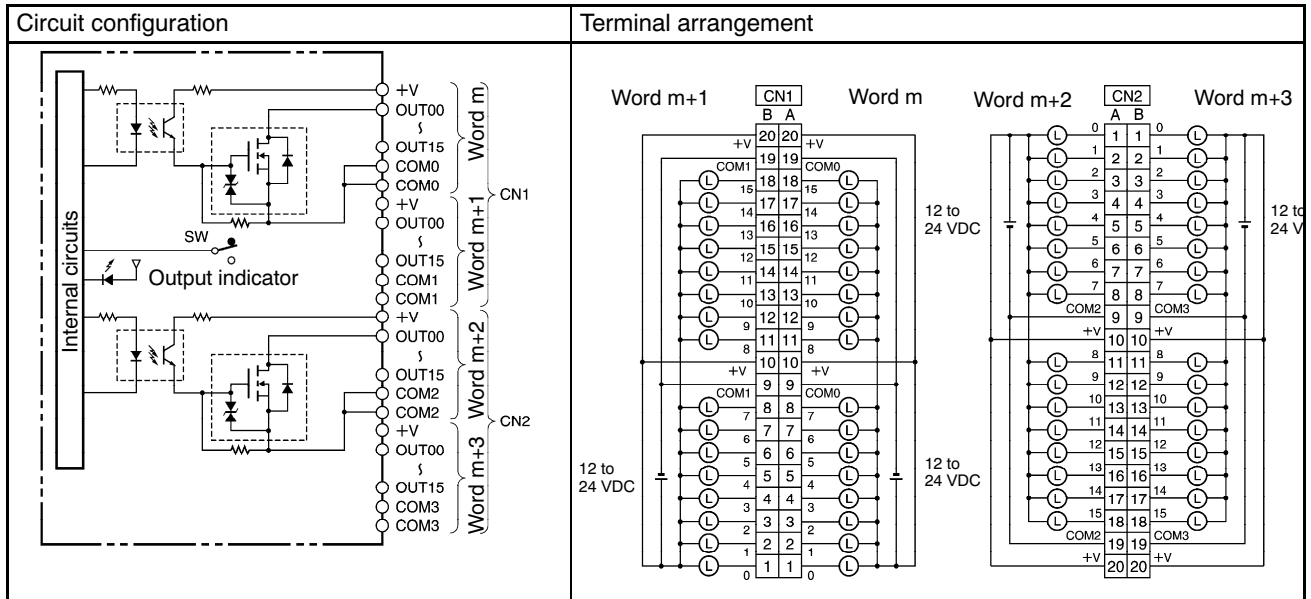

CJ1W-OD262

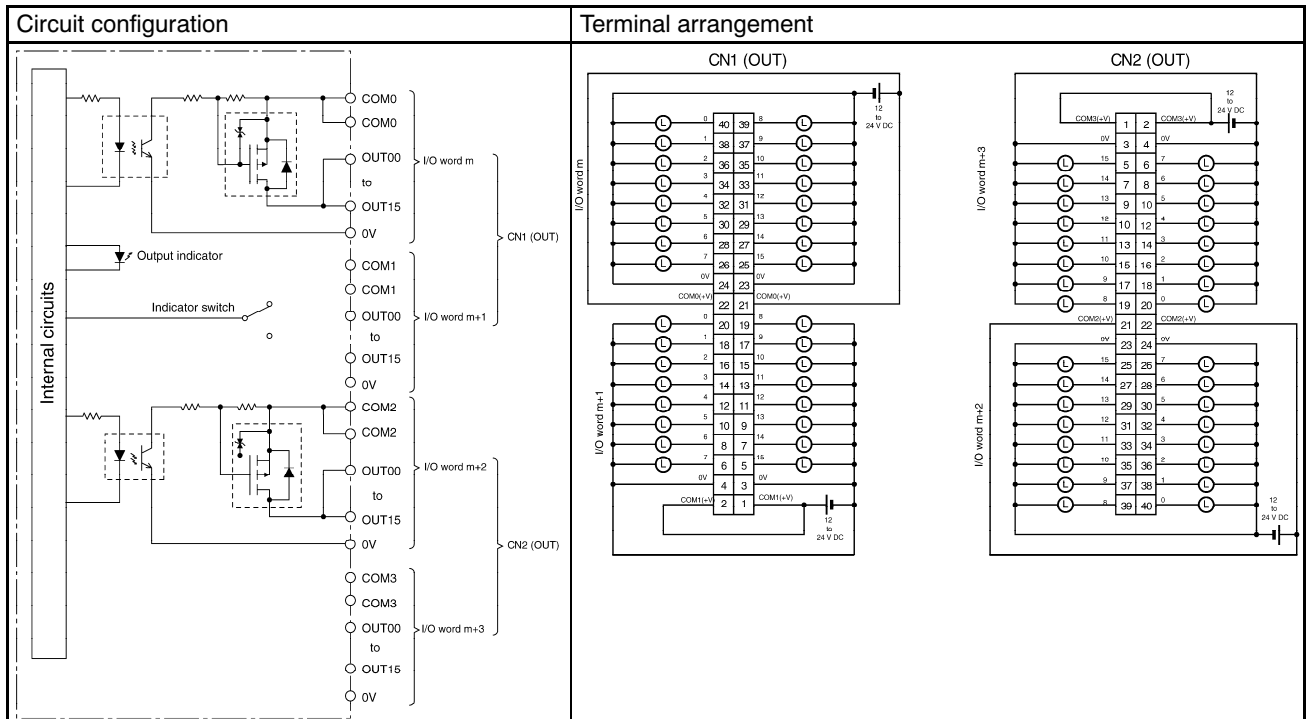

Output Modules

Transistor Output Module Circuit Configuration and Terminal Arrangement (continued)

CJ1W-OD263

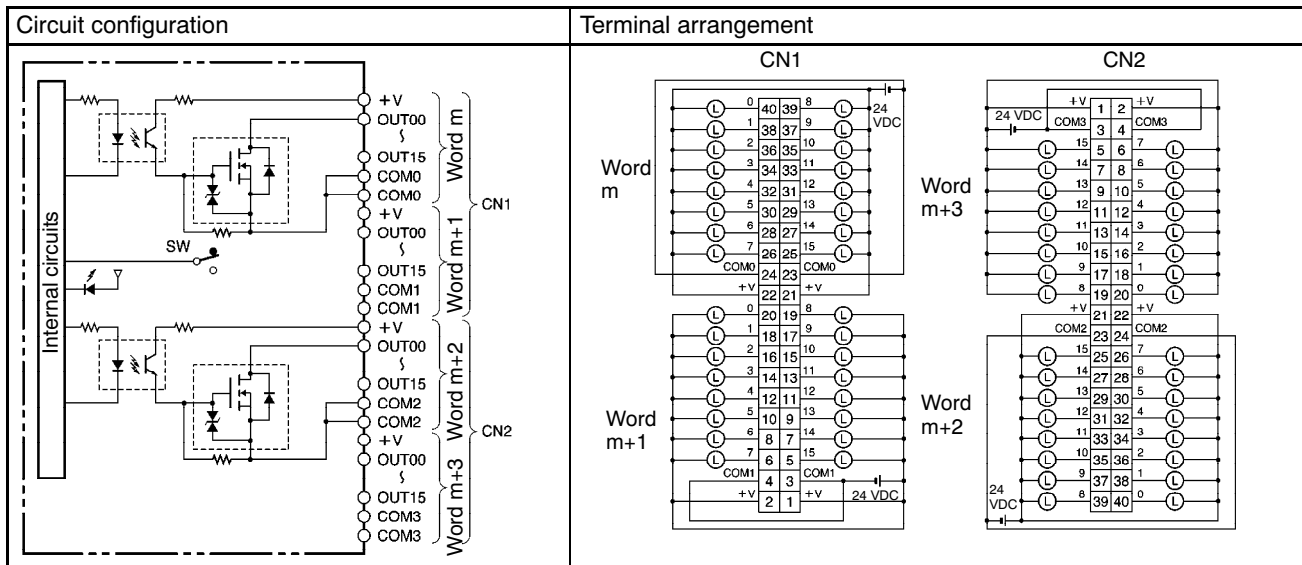

■ Triac Output Module Circuit Configuration and Terminal Arrangement

CJ1W-OA201

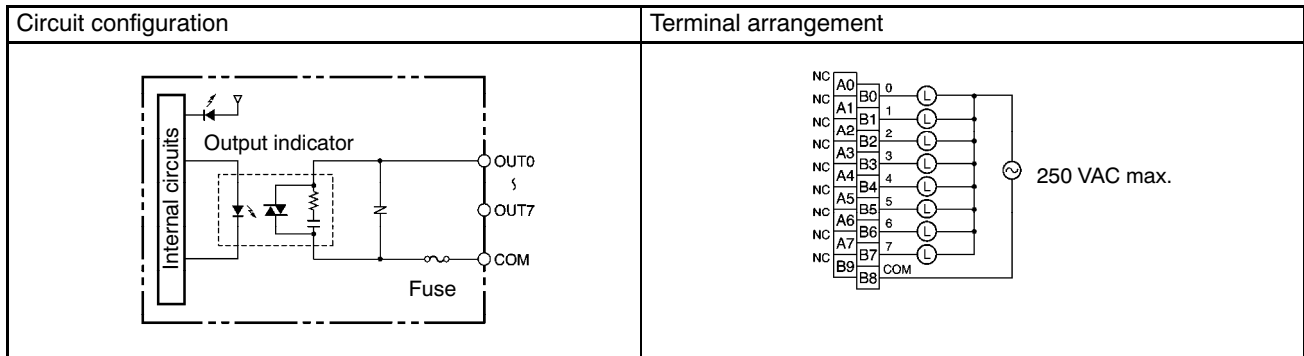

Mixed I/O Modules

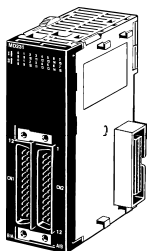

I/O Units (32 points)
CJ1W-MD23□

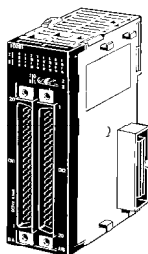

I/O Units (64 points)
CJ1W-MD26□
CJ1W-MD563

■ DC Input/Transistor Output Units

Classification	Inputs/ Outputs	Input voltage	Input current (typical)	Max. output switching capacity	Connections	Model
Basic I/O Unit	16 inputs/ 16 outputs	24 VDC	7 mA	12 to 24 VDC, 0.5 A/pt, 2.0 A/Unit, sinking outputs	Fujitsu-compatible connector	CJ1W-MD231
				24 VDC, 0.5 A/pt, 2.0 A/Unit, sourcing	MIL connector	CJ1W-MD232
				12 to 24 VDC, 0.5 A/pt, 2.0 A/Unit, sinking outputs	MIL connector	CJ1W-MD233
	32 inputs/ 32 outputs		4.1 mA	12 to 24 VDC, 0.3 A/pt, 3.2 A/Unit, sinking outputs	Fujitsu-compatible connector	CJ1W-MD261
					MIL connector	CJ1W-MD263

■ TTL I/O Units

Classification	Inputs/ Outputs	Input voltage	Input current (typical)	Max. output switching capacity	Connections	Model
Basic I/O Unit	32 inputs/ 32 outputs	5 VDC	3.5 mA	5 VDC, 35 mA/pt, 1.12 A/Unit	MIL connector	CJ1W-MD563

■ Wiring and Cabling Examples

32-Point Mixed I/O Modules

- CJ1W-MD231 (Fujitsu connector, I/O Unit)
- CJ1W-MD232 (MIL connector, I/O Unit)
- CJ1W-MD233 (MIL connector, I/O Unit)

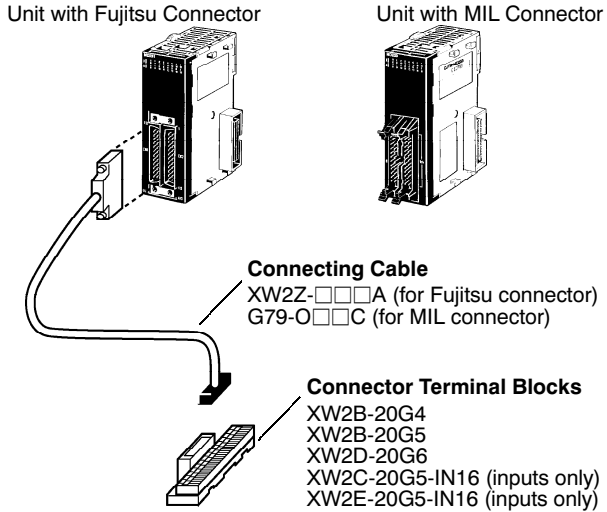

64-Point Mixed I/O Modules

- CJ1W-MD261 (Fujitsu connector I/O Unit)
- CJ1W-MD263 (MIL connector, I/O Unit)
- CJ1W-MD563 (MIL connector, I/O Unit)

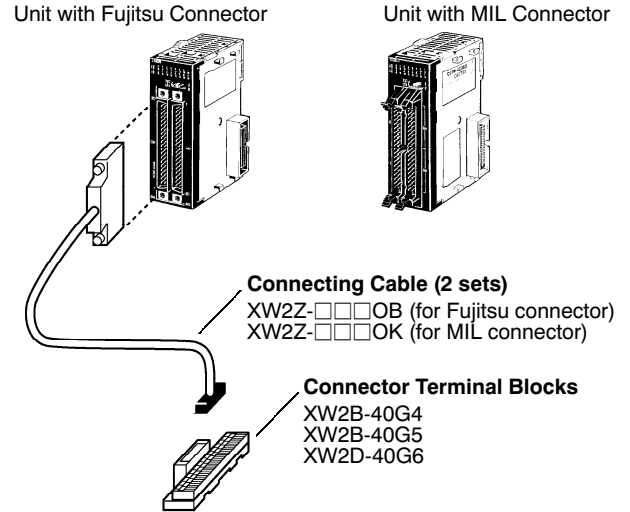

Additional Information: For more details and specifications on cables and terminal blocks, refer to Manual No. W393 or check the Wiring Solutions section of this catalog for more options.

32-Point Mixed I/O Modules

- CJ1W-MD231 (Fujitsu connector, I/O Unit)
- CJ1W-MD232 (MIL connector, I/O Unit)
- CJ1W-MD233 (MIL connector, I/O Unit)

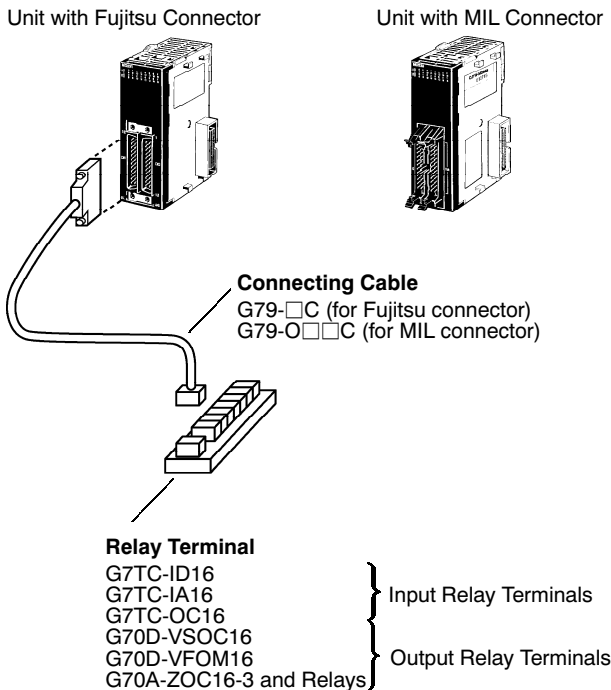

64-Point Mixed I/O Modules

- CJ1W-MD261 (Fujitsu connector, I/O Unit)
- CJ1W-MD263 (MIL connector, I/O Unit)

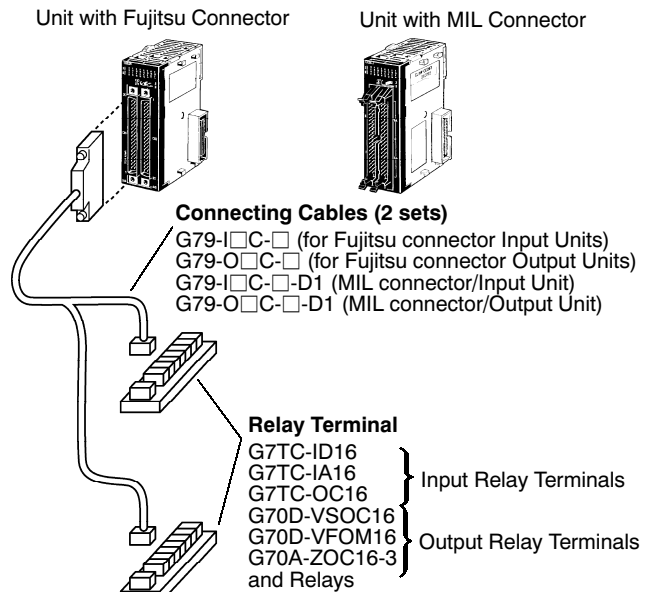

Mixed I/O Modules

■ Mixed I/O Module Circuit Configuration and Terminal Arrangement

CJ1W-MD231

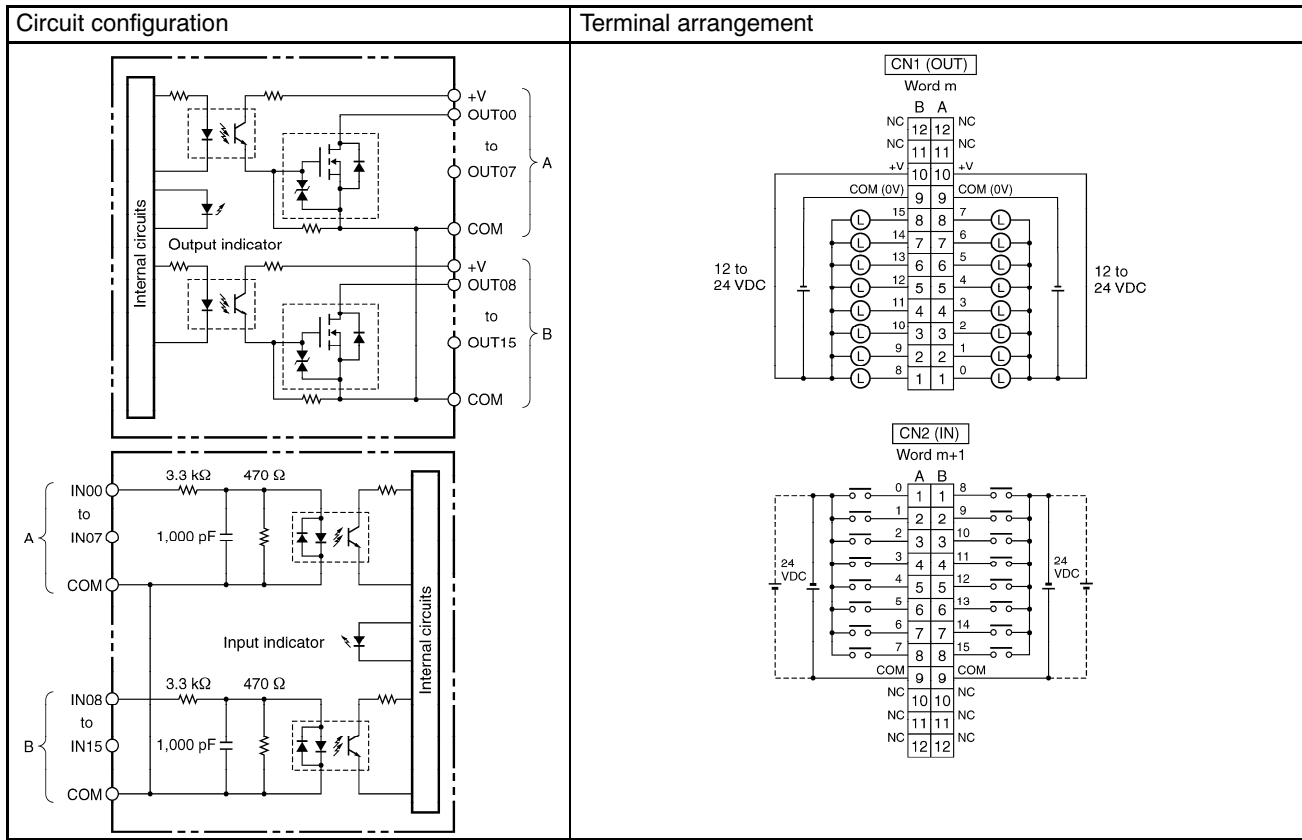

CJ1W-MD232

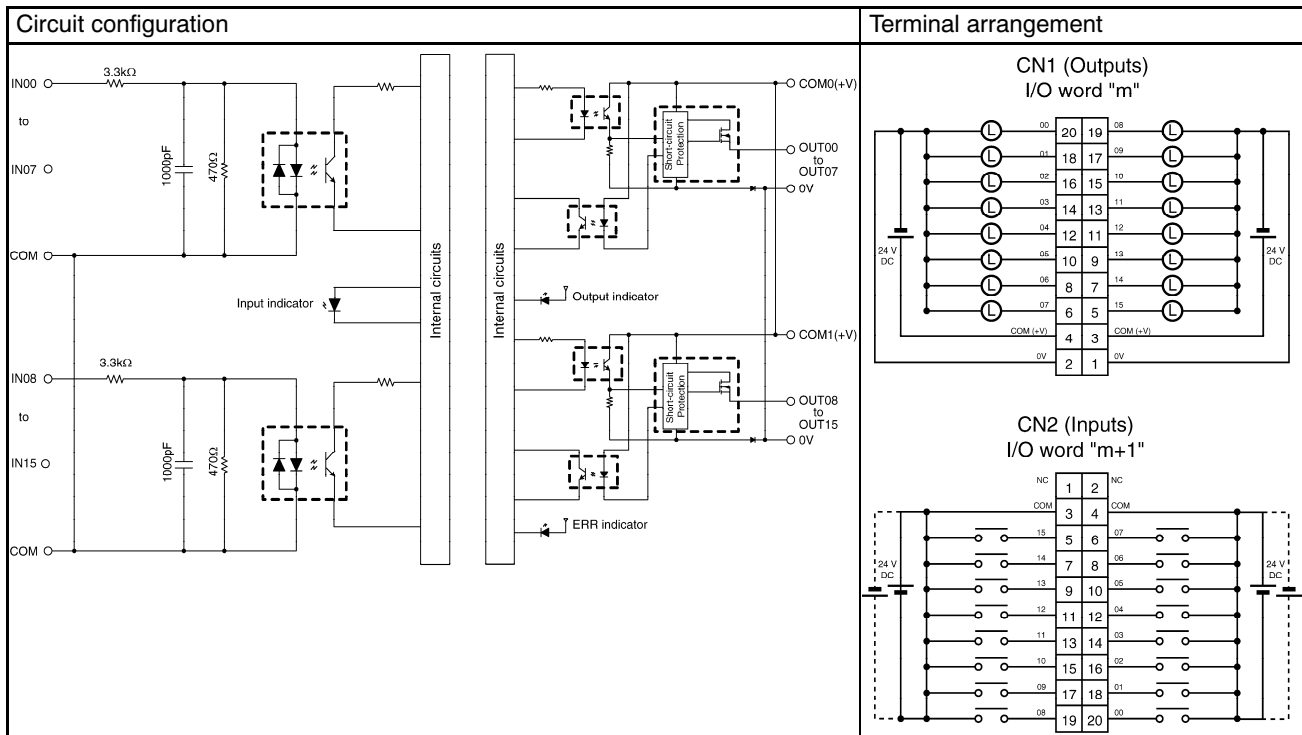

Mixed I/O Module Circuit Configuration and Terminal Arrangement (continued)

CJ1W-MD233

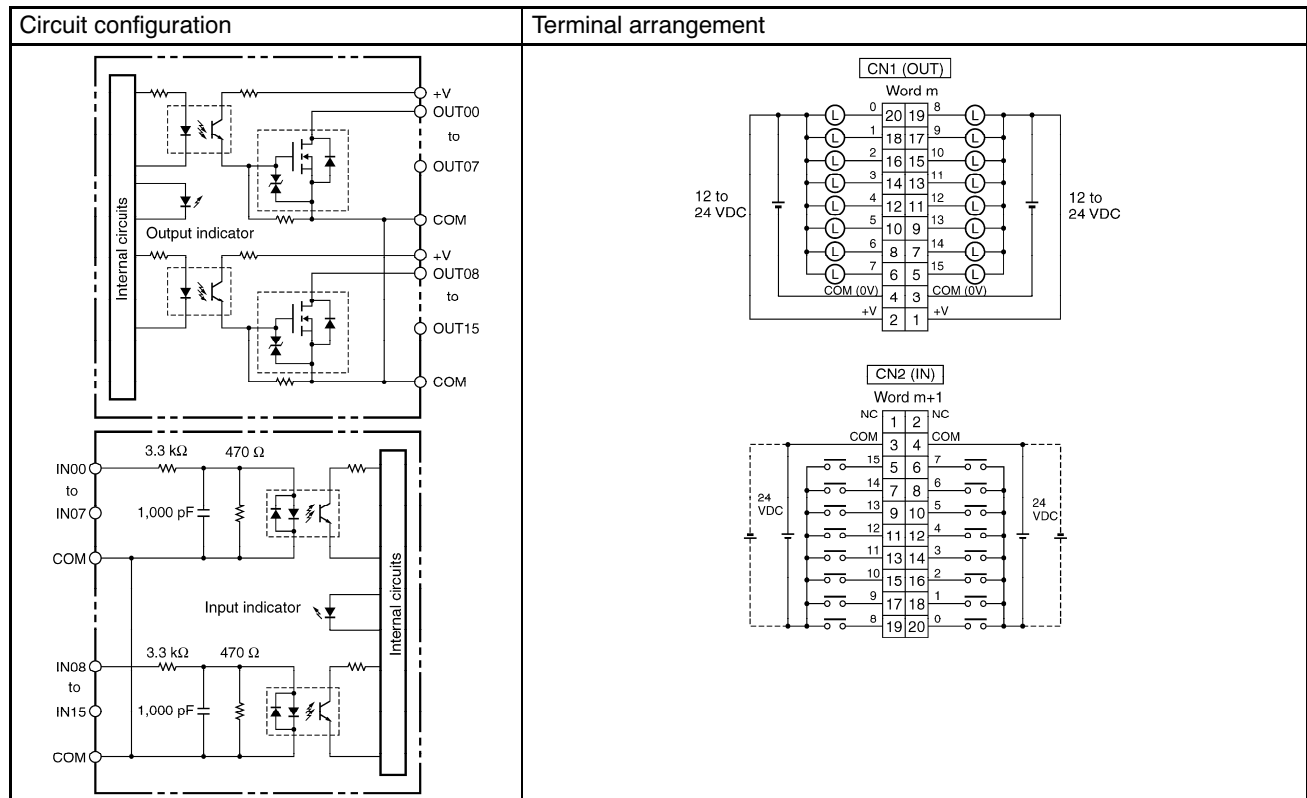

CJ1W-MD261

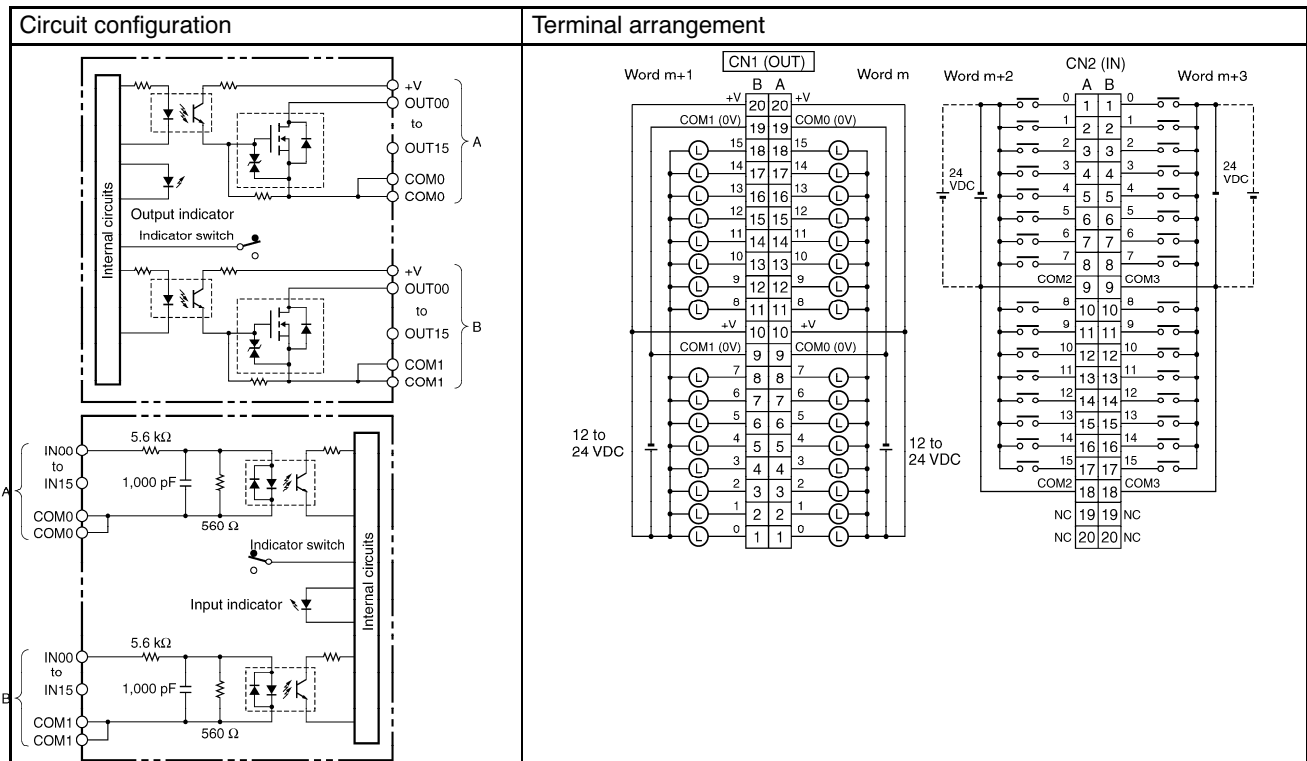

Mixed I/O Modules

Mixed I/O Module Circuit Configuration and Terminal Arrangement (continued)

CJ1W-MD263

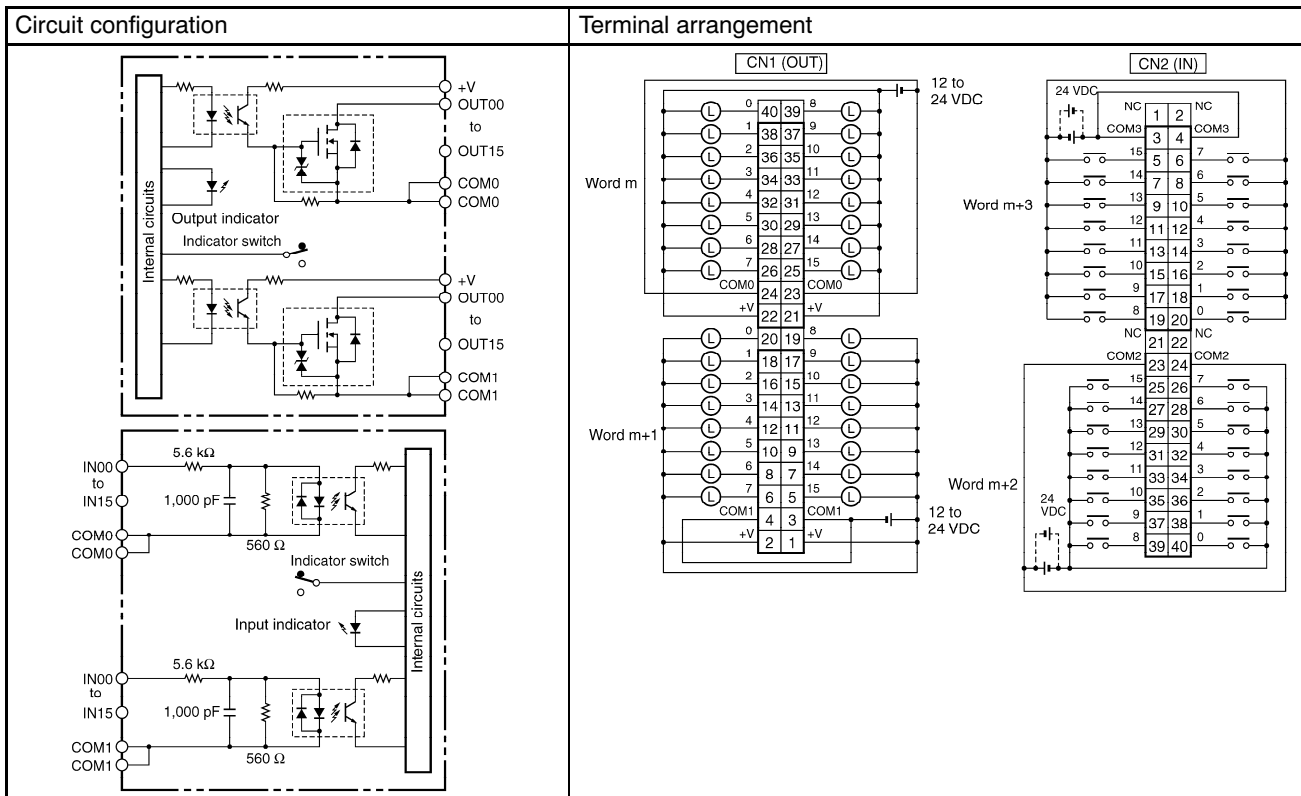

CJ1W-MD563

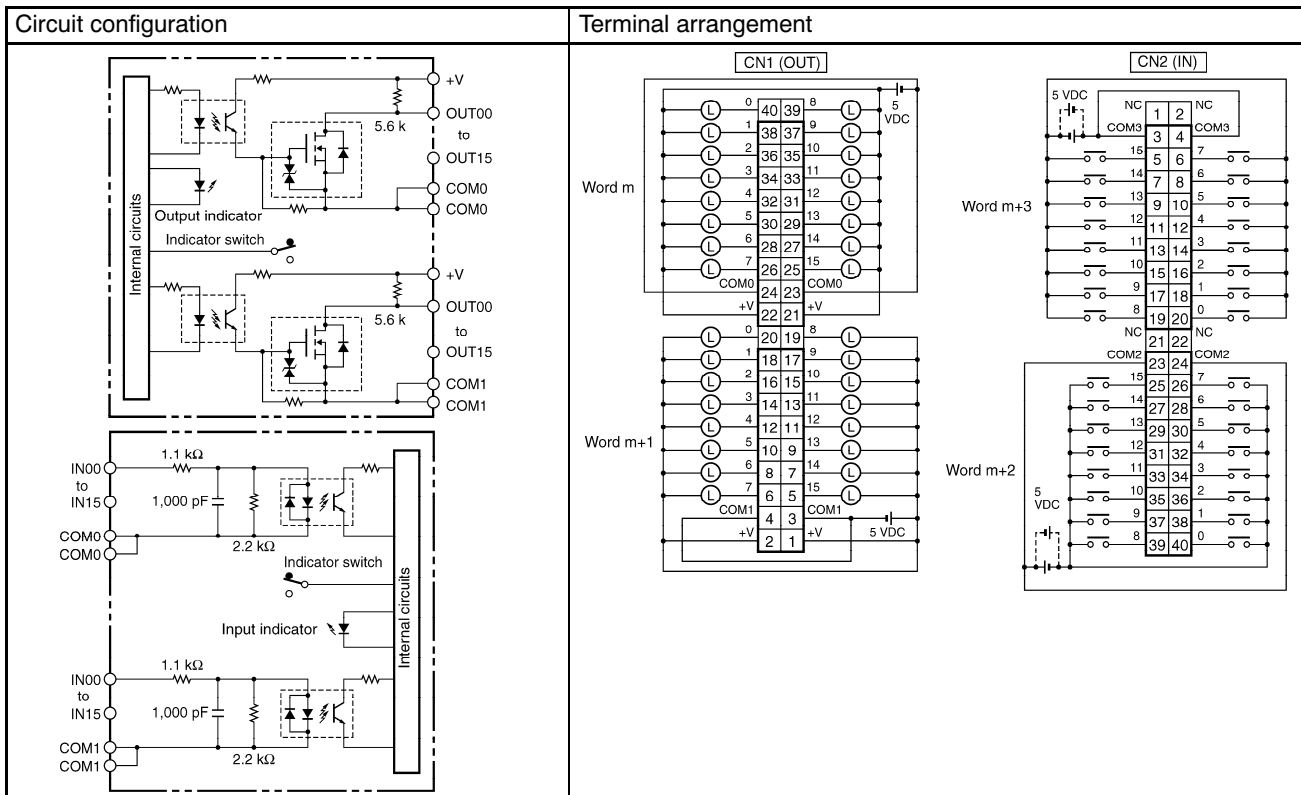

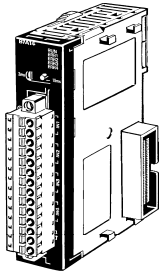

CJ1W-B7A22
CJ1W-B7A14
CJ1W-B7A04

■ Features

- Wire remote switches, lamps, and other devices without being concerned with communications while also reducing wiring both inside and outside the control panel.
- Handles up to 64 signals with each module.
- Communications possible for up to 500 m.
- No complicated settings or programming (operates as a Basic I/O Unit).

■ System Configuration

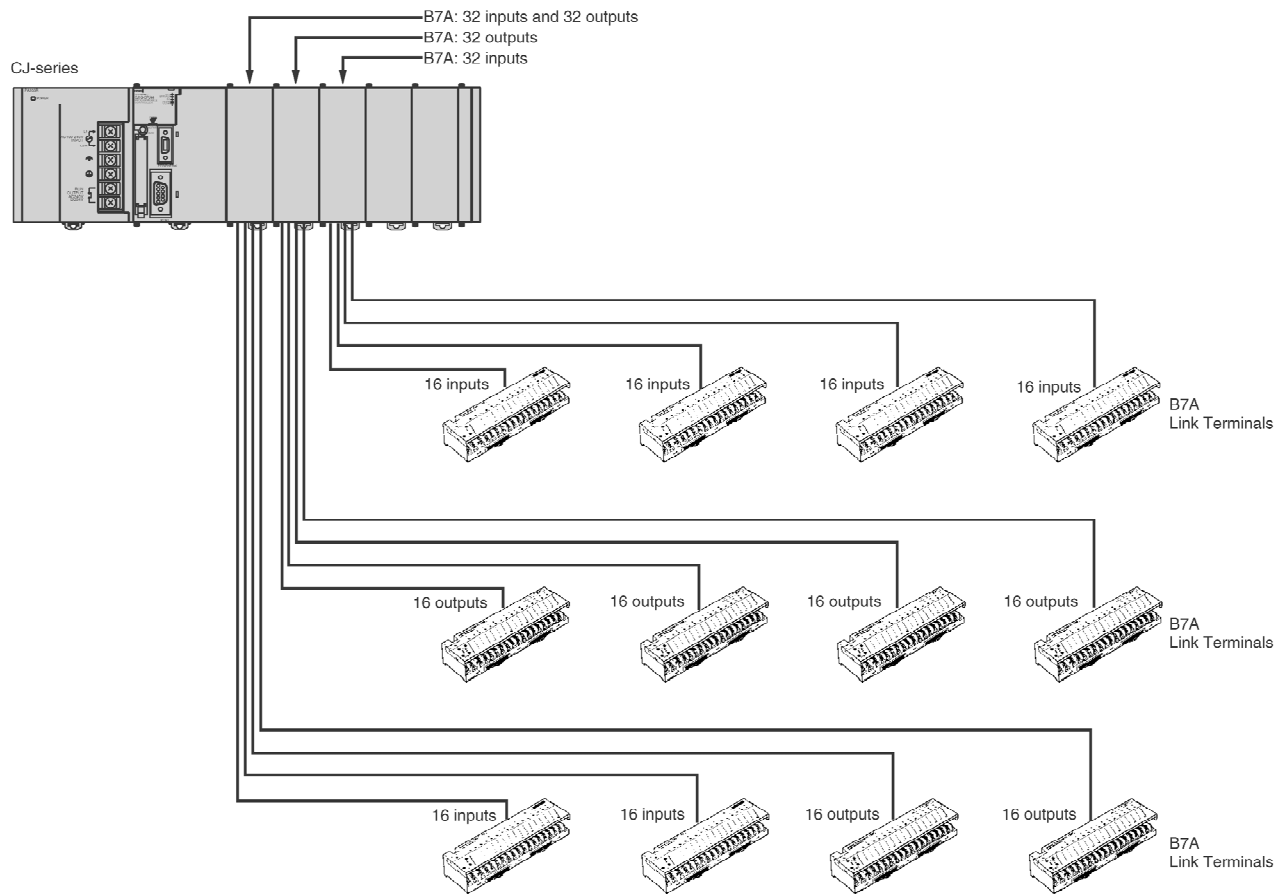

B7A Interface Modules

■ Specifications

Item		Specification		
		CJ1W-B7A22	CJ1W-B7A14	CJ1W-B7A04
Unit classification		Basic I/O Unit		
Inputs/Outputs		32 inputs/32 outputs	64 inputs	64 outputs
Transmission distance	High-speed operation	Same power supply for Unit and Link Terminals	With 0.75 mm ² or larger communications line Not shielded: 10 m max. Shielded: 50 m max.	
		Separate power supplies for Unit and Link Terminals	With 0.75 mm ² or larger communications line Not shielded: 10 m max. Shielded: 100 m max.	
	Normal operation	Same power supply for Unit and Link Terminals	With 0.75 mm ² or larger communications line: 100 m max.	
		Separate power supplies for Unit and Link Terminals	With 0.75 mm ² or larger communications line: 500 m max.	
Transmission delay		Normal operation: 19 ms (typical), High-speed operation: 3 ms (typical)		
Power supply voltage		12 to 24 VDC (allowable range: 10.8 to 26.4 VDC)		
I/O word allocations		Words are allocated according to the location the Unit is connected in the PLC. Four words (64 points) are allocated to each Unit.		

■ Applicable B7A Link Terminals

Input Terminals

Type	Model	Transmission Delay
Screw Terminals	B7A-T6□1	Normal (19.2 ms)
	B7AS-T6□1	
	B7A-T6□6	High Speed (3 ms)
	B7AS-T6□6	
Modules	B7A-T6D2	Normal (19.2 ms)
	B7A-T6D7	High Speed (3 ms)
PLC connectors	B7A-T□E3	Normal (19.2 ms)
	B7A-T□E8	High Speed (3 ms)

I/O Terminals and Input Terminal with 32 Inputs

Type	Model	Transmission Delay	
Screw Terminals	Mixed I/O	B7AM-6BS	Normal (19.2 ms) or High Speed (3 ms)
	32-point input	B7AS-RT3BS	

Output Terminals

Type	Model	Transmission Delay
Screw Terminals	B7A-R6□□1	Normal (19.2 ms)
	B7AS-R6□□1	
	B7A-R6□□6	High Speed (3 ms)
	B7AS-R6□□6	
Relay outputs	G70D-R6R□1-B7A	Normal (19.2 ms)
	G70D-R6M□1-B7A	High Speed (3 ms)
Modules	B7A-R6A52	Normal (19.2 ms)
	B7A-R6A57	High Speed (3 ms)
PLC connectors	B7A-R□A□3	Normal (19.2 ms)
	B7A-R□A□8	High Speed (3 ms)

- Note 1. Use a B7A Link Terminal that has the same delay at the B7A Interface Unit.
 2. B7A Link Terminal with 10 points cannot be connected.