

# Screw-less Clamp Terminals with Transistors

# DRT2-□D16SL(H)(-1)/□D32SLH(-1)

## Reduced Wiring and Labor on Factory Sites with Screw-less Terminal Wiring

- Screw-less structure eliminates tightening work.
- Detachable terminal blocks for easier maintenance.
- Single-step wiring by simply inserting pole terminals.

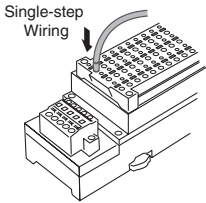

- Applicable wire sizes range from AWG24 to AWG16 (0.2 to 1.25 mm<sup>2</sup> dia.)

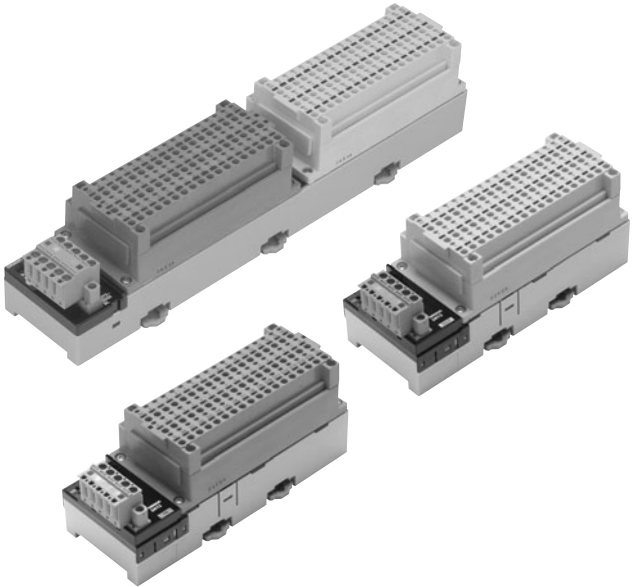

## Smart Slave Functions

- Operation time monitor
- Contact operation counter
- Unit conduction time monitor
- Total ON time monitor
- Unit comments
- Connected device comments
- Network power supply voltage monitor
- I/O power supply monitor function
- Communications error log function
- Input filter (input or I/O only)
- Power-ON inrush current protection (input or I/O only)
- Sensor power supply short-circuit detection (input or I/O only)
- Disconnected sensor detection (input or I/O only)
- External load short-circuit detection (output only)
- Disconnection detection (output or I/O only)
- Removable terminal block
- Communications speed auto-detection
- No need to wire Unit power supply
- Last maintenance date

## Ordering Information

Short/disconnection detection	Specifications			I/O connections	Rated internal circuit power supply voltage	Rated I/O power supply voltage	Model					
Supported	Inputs	NPN (+ common)	16 points	Clamp terminals	Supplied from communications connector.	24 VDC	DRT2-ID16SLH					
		PNP (- common)					DRT2-ID16SLH-1					
	Outputs	NPN (- common)					DRT2-OD16SLH					
		PNP (+ common)					DRT2-OD16SLH-1					
Not supported	Inputs	NPN (+ common)					32 points	Clamp terminals	Supplied from communications connector.	24 VDC	DRT2-ID16SL	
		PNP (- common)									DRT2-ID16SL-1	
	Outputs	NPN (- common)									DRT2-OD16SL	
		PNP (+ common)									DRT2-OD16SL-1	
Supported	Inputs	NPN (+ common)	16 inputs/ 16 outputs	Clamp terminals	Supplied from communications connector.	24 VDC					DRT2-ID32SLH	
		PNP (- common)									DRT2-ID32SLH-1	
		Outputs									NPN (- common)	DRT2-OD32SLH
											PNP (+ common)	DRT2-OD32SLH-1
	I/O	NPN (input: + common, output: - common)					DRT2-MD32SLH					
		PNP (input: - common, output: + common)					DRT2-MD32SLH-1					

## General Specifications

Communications power supply voltage	11 to 25 VDC (Supplied from the communications connector.)
Communications power supply current consumption	DRT2-ID32SLH(-1): 65 mA DRT2-OD32SLH(-1): 55 mA DRT2-MD32SLH(-1): 60 mA
Noise immunity	Conforms to IEC61000-4-4, 2 kV (power line)
Vibration resistance	10 to 60 Hz, 0.7-mm double amplitude, 60 to 150 Hz, 50 m/s <sup>2</sup> for 80 min each in the X, Y, and Z directions
Shock resistance	150m/s <sup>2</sup> , 6 directions, 3 times each
Dielectric strength	500 VAC (between isolated circuits)
Insulation resistance	20 MΩ min. (between isolated circuits)
Ambient operating temperature	-10°C to 55°C
Ambient operating humidity	25% to 85% (with no condensation)
Ambient operating atmosphere	No corrosive gases
Ambient storage temperature	-20°C to 65°C
Mounting method	DIN 35 mm-track mounting
Weight	480 g max.

## I/O Specifications

### ● 16-point Inputs Terminals with Transistors (Input Specifications)

Item	Model	DRT2-ID16SL	DRT2-ID16SL-1	DRT2-ID16SLH	DRT2-ID16SLH-1
Internal I/O common		NPN	PNP	NPN	PNP
Input points		16 inputs			
I/O power supply voltage		20.4 to 26.4 VDC (24 VDC -15%/+10%)			
Input current		24 VDC: 6.0 mA max./point 17 VDC: 3.0 mA max./point			
Input resistance		4 kΩ			
ON delay time		1.5 ms max.			
OFF delay time		1.5 ms max.			
ON voltage		15 VDC min. (between each input terminal and V)	15 VDC min. (between each input terminal and G)	15 VDC min. (between each input terminal and V)	15 VDC min. (between each input terminal and G)
OFF voltage		5 VDC max. (between each input terminal and V)	5 VDC max. (between each input terminal and G)	5 VDC max. (between each input terminal and V)	5 VDC max. (between each input terminal and G)
ON current		3.0 mA max.			
OFF current		1.0 mA max.			
Number of circuits per common		16 per common			
Power short-circuit protection		--		Operates at 50 mA/point min.	
Disconnection detection		--		Operates at 0.3 mA/point max.	
Input power supply current		100 mA per point		50 mA per point	

### ● 32-point Inputs Terminals with Transistors (Input Specifications)

Item	Model	DRT2-ID32SLH	DRT2-ID32SLH-1
Internal I/O common		NPN	PNP
Input points		32 inputs	
I/O power supply voltage		20.4 to 26.4 VDC (24 VDC -15%/+10%)	
Input current		6.0 mA/6.0 mA max. per point at 24 VDC 3.0 mA max. per point at 17 VDC	
Input resistance		4 kΩ	
ON delay time		1.5 ms max.	
OFF delay time		1.5 ms max.	
ON voltage		15 VDC min. (between each input terminal and V)	15 VDC min. (between each input terminal and G)
OFF voltage		5 VDC max. (between each input terminal and V)	5 VDC max. (between each input terminal and G)
ON current		3 mA min.	
OFF current		1.0 mA max.	
Number of circuits per common		16 per common	
Power short-circuit protection		Operates at 50 mA/point min.	
Disconnection detection		Operates at 0.3 mA/point max.	

● 16-point Outputs Terminals with Transistors (Output Specifications)

Item	Model	DRT2-OD16SL	DRT2-OD16SL-1	DRT2-OD16SLH	DRT2-OD16SLH-1
Internal I/O common		NPN	PNP	NPN	PNP
I/O points		16 outputs			
I/O power supply voltage		20.4 to 26.4 VDC (24 VDC -15%/+10%)			
Output current		0.5 A per point, 4 A per common			
Residual voltage		1.2 V max.			
Leakage current		0.1 mA max.		0.1 mA max. (See Note: 1.)	
ON delay time		0.5 ms max.			
OFF delay time		1.5 ms max.			
Disconnection detection		--		(See Note: 2.)	
Output power supply current		100 mA per point			
Output for errors		According to hold/clear setting for errors (default: clear)			

**Note 1:** To enable detection of external load disconnections, a current of 0.1 mA or less is output to the load even when the output is OFF. Make sure that the load will not operate for this current.

**Note 2:** Disconnection detection can be used when the load current is 3 mA or higher. If the load current is less than 3 mA, disconnections may be falsely detected.

● 32-point Outputs Terminals with Transistors (Output Specifications)

Item	Model	DRT2-OD32SLH	DRT2-OD32SLH-1
Internal I/O common		NPN	PNP
I/O points		32 outputs	
I/O power supply voltage		20.4 to 26.4 VDC (24 VDC -15%/+10%)	
Output current		0.5 A per point, 4 A per common	
Residual voltage		1.2 V max.	
Leakage current		0.1 mA max.	
ON delay time		0.5 ms max.	
OFF delay time		1.5 ms max.	
Disconnection detection		Operates at current consumption of 3 mA/point max. (Not detected at 3 mA or higher.)	
Output for errors		According to hold/clear setting for errors (default: clear)	

● 16-point Inputs/16-point Outputs Terminals with Transistors (Input Specifications)

Item	Model	DRT2-MD32SLH	DRT2-MD32SLH-1
Internal I/O common		NPN	PNP
Input points		16 inputs	
I/O power supply voltage		20.4 to 26.4 VDC (24 VDC -15%/+10%)	
Input current		6.0 mA max. per point at 24 VDC 3.0 mA max. per point at 17 VDC	
Input resistance		4 kΩ	
ON delay time		1.5 ms max.	
OFF delay time		1.5 ms max.	
ON voltage		15 VDC min. (between each input terminal and V)	15 VDC min. (between each input terminal and G)
OFF voltage		5 VDC max. (between each input terminal and V)	5 VDC max. (between each input terminal and G)
ON current		3 mA min.	
OFF current		1.0 mA max.	
Number of circuits per common		16 per common	
Power short-circuit protection		Operates at 50 mA/point min.	
Disconnection detection		Operates at 0.3 mA/point max	

● 16-point Inputs/16-point Outputs Terminals with Transistors (Output Specifications)

Item	Model	DRT2-MD32SLH	DRT2-MD32SLH-1
Internal I/O common		NPN	PNP
I/O points		16 outputs	
I/O power supply voltage		20.4 to 26.4 VDC (24 VDC -15%/+10%)	
Output current		0.5 A per point, 4 A per common	
Residual voltage		1.2 V max.	
Leakage current		0.1 mA max.	
ON delay time		0.5 ms max.	
OFF delay time		1.5 ms max.	
Disconnection detection		Operates at current consumption of 3 mA/point max. (Not detected at 3 mA or higher.)	
Output for errors		According to hold/clear setting for errors (default: clear)	

Dimensions

DRT2-ID16SLH(-1)  
 DRT2-OD16SLH(-1)  
 DRT2-ID16SL(-1)  
 DRT2-OD16SL(-1)

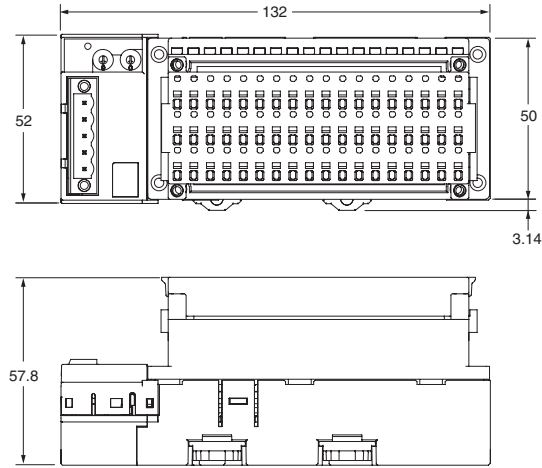

DRT2-ID32SLH(-1)  
 DRT2-OD32SLH(-1)  
 DRT2-MD32SLH(-1)

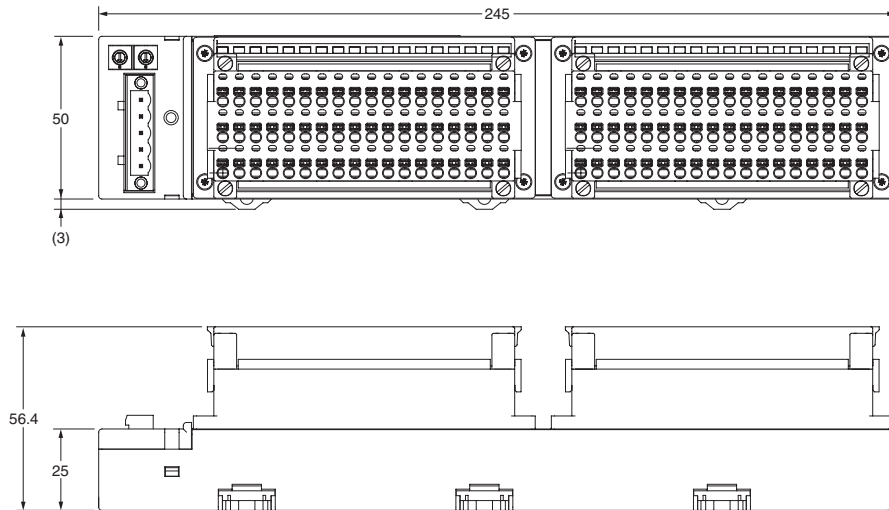

Wiring Diagrams

DRT2-ID16SL  
 (NPN)

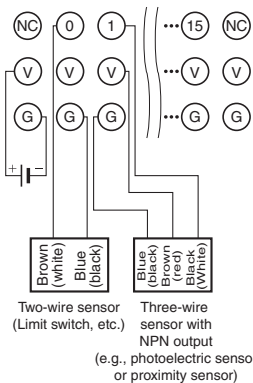

DRT2-ID16SL-1  
 (PNP)

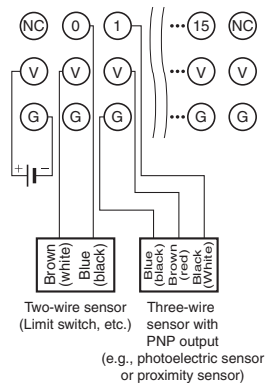

DRT2-ID16SLH  
 (NPN)

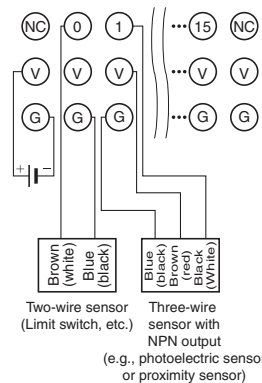

DRT2-ID16SLH-1  
 (PNP)

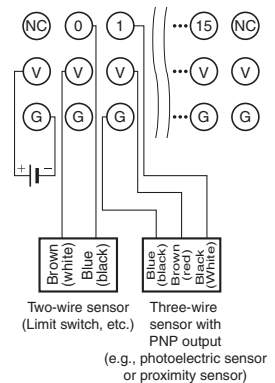

**DRT2-ID32SLH (NPN)**

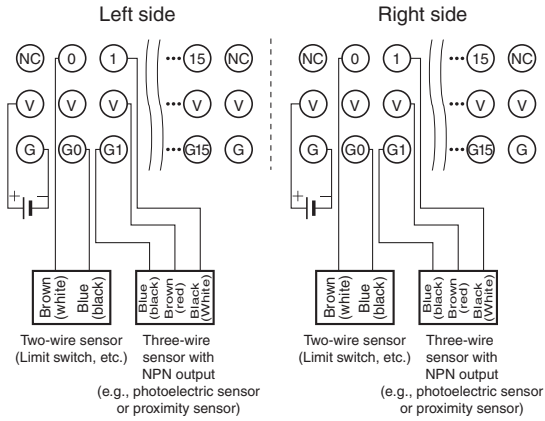

**DRT2-ID32SLH-1 (PNP)**

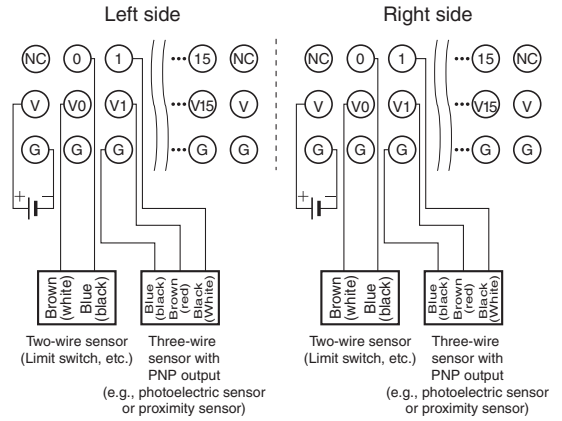

**DRT2-OD16SL (NPN)**

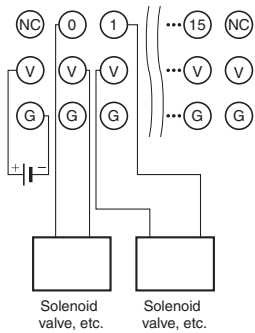

**DRT2-OD16SL-1 (PNP)**

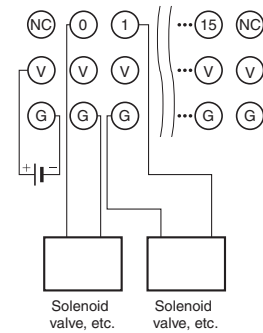

**DRT2-OD16SLH (NPN)**

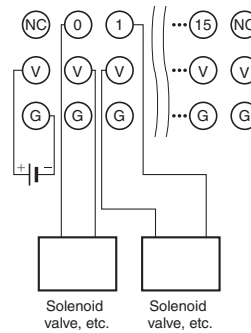

**DRT2-OD16SLH-1 (PNP)**

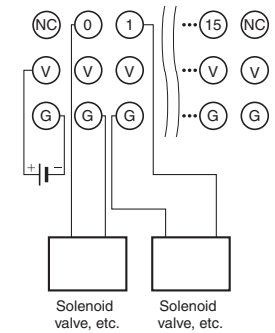

**DRT2-OD32SLH (NPN)**

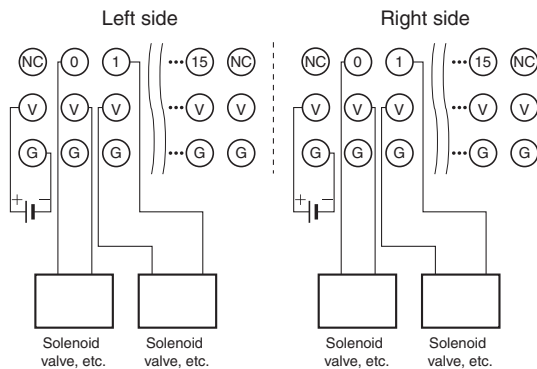

**DRT2-OD32SLH-1 (PNP)**

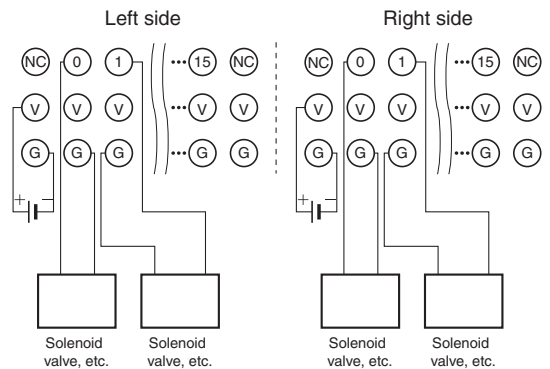

**DRT2-MD32SLH (NPN)**

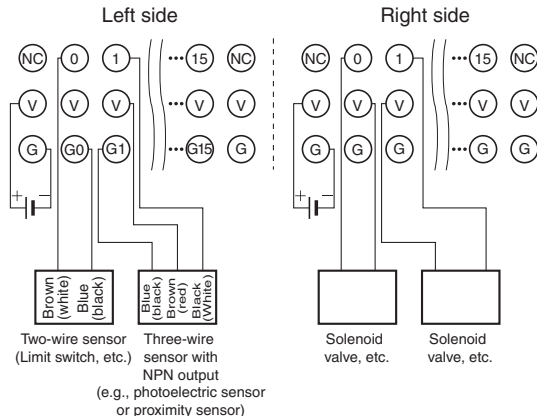

**DRT2-MD32SLH-1 (PNP)**

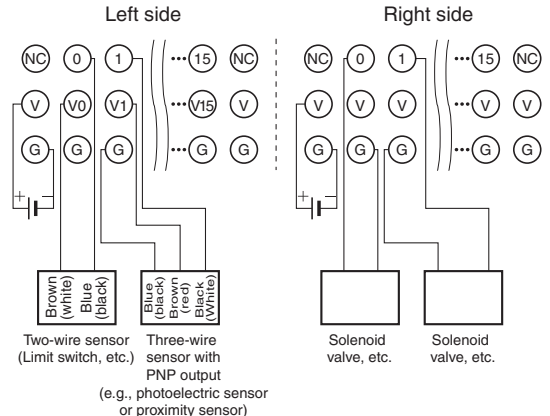

## Read and Understand This Catalog

Please read and understand this catalog before purchasing the products. Please consult your OMRON representative if you have any questions or comments.

## Warranty and Limitations of Liability

### WARRANTY

OMRON's exclusive warranty is that the products are free from defects in materials and workmanship for a period of one year (or other period if specified) from date of sale by OMRON.

OMRON MAKES NO WARRANTY OR REPRESENTATION, EXPRESS OR IMPLIED, REGARDING NON-INFRINGEMENT, MERCHANTABILITY, OR FITNESS FOR PARTICULAR PURPOSE OF THE PRODUCTS. ANY BUYER OR USER ACKNOWLEDGES THAT THE BUYER OR USER ALONE HAS DETERMINED THAT THE PRODUCTS WILL SUITABLY MEET THE REQUIREMENTS OF THEIR INTENDED USE. OMRON DISCLAIMS ALL OTHER WARRANTIES, EXPRESS OR IMPLIED.

### LIMITATIONS OF LIABILITY

OMRON SHALL NOT BE RESPONSIBLE FOR SPECIAL, INDIRECT, OR CONSEQUENTIAL DAMAGES, LOSS OF PROFITS OR COMMERCIAL LOSS IN ANY WAY CONNECTED WITH THE PRODUCTS, WHETHER SUCH CLAIM IS BASED ON CONTRACT, WARRANTY, NEGLIGENCE, OR STRICT LIABILITY.

In no event shall the responsibility of OMRON for any act exceed the individual price of the product on which liability is asserted.

IN NO EVENT SHALL OMRON BE RESPONSIBLE FOR WARRANTY, REPAIR, OR OTHER CLAIMS REGARDING THE PRODUCTS UNLESS OMRON'S ANALYSIS CONFIRMS THAT THE PRODUCTS WERE PROPERLY HANDLED, STORED, INSTALLED, AND MAINTAINED AND NOT SUBJECT TO CONTAMINATION, ABUSE, MISUSE, OR INAPPROPRIATE MODIFICATION OR REPAIR.

## Application Considerations

### SUITABILITY FOR USE

OMRON shall not be responsible for conformity with any standards, codes, or regulations that apply to the combination of products in the customer's application or use of the products.

At the customer's request, OMRON will provide applicable third party certification documents identifying ratings and limitations of use that apply to the products. This information by itself is not sufficient for a complete determination of the suitability of the products in combination with the end product, machine, system, or other application or use.

The following are some examples of applications for which particular attention must be given. This is not intended to be an exhaustive list of all possible uses of the products, nor is it intended to imply that the uses listed may be suitable for the products:

- Outdoor use, uses involving potential chemical contamination or electrical interference, or conditions or uses not described in this catalog.
- Nuclear energy control systems, combustion systems, railroad systems, aviation systems, medical equipment, amusement machines, vehicles, safety equipment, and installations subject to separate industry or government regulations.
- Systems, machines, and equipment that could present a risk to life or property.

Please know and observe all prohibitions of use applicable to the products.

NEVER USE THE PRODUCTS FOR AN APPLICATION INVOLVING SERIOUS RISK TO LIFE OR PROPERTY WITHOUT ENSURING THAT THE SYSTEM AS A WHOLE HAS BEEN DESIGNED TO ADDRESS THE RISKS, AND THAT THE OMRON PRODUCTS ARE PROPERLY RATED AND INSTALLED FOR THE INTENDED USE WITHIN THE OVERALL EQUIPMENT OR SYSTEM.

### PROGRAMMABLE PRODUCTS

OMRON shall not be responsible for the user's programming of a programmable product, or any consequence thereof.

## Disclaimers

### CHANGE IN SPECIFICATIONS

Product specifications and accessories may be changed at any time based on improvements and other reasons.

It is our practice to change model numbers when published ratings or features are changed, or when significant construction changes are made. However, some specifications of the products may be changed without any notice. When in doubt, special model numbers may be assigned to fix or establish key specifications for your application on your request. Please consult with your OMRON representative at any time to confirm actual specifications of purchased products.

### DIMENSIONS AND WEIGHTS

Dimensions and weights are nominal and are not to be used for manufacturing purposes, even when tolerances are shown.

### PERFORMANCE DATA

Performance data given in this catalog is provided as a guide for the user in determining suitability and does not constitute a warranty. It may represent the result of OMRON's test conditions, and the users must correlate it to actual application requirements. Actual performance is subject to the OMRON Warranty and Limitations of Liability.

### ERRORS AND OMISSIONS

The information in this document has been carefully checked and is believed to be accurate; however, no responsibility is assumed for clerical, typographical, or proofreading errors, or omissions.

2012.5

In the interest of product improvement, specifications are subject to change without notice.

**OMRON Corporation**  
Industrial Automation Company

<http://www.ia.omron.com/>

(c)Copyright OMRON Corporation 2012 All Right Reserved.