

e-CON Connector Terminals DRT2-□D16S(-1)

Includes Sensor Connector That Conforms to Industry Standards And Can Be Used to Connect Sensors with Pre-wired Cables without Using Special Tools.



- Equipped with the standard Smart Slave functions that provide powerful preventative maintenance and troubleshooting capabilities.
- Digital I/O Terminal compatible with industry-standard sensor connectors
- Connect sensors easily without special tools. Reduce time required for wiring.
- Load short-circuit detection.

Smart Slave Functions

Operation time monitor (I/O only)	Contact operation counter	Unit conduction time monitor
Total ON time monitor	Unit comments	Connected device comments
Network power supply voltage monitor	Communications error log function	Input filter
Power-ON inrush current protection	Sensor power supply short-circuit detection	External load short-circuit detection function
Communications speed auto-detection	No need to wire Unit power supply	No need to wire input device power supply
Last maintenance date		

Ordering Information

Specifications			I/O connections	Rated internal circuit power supply voltage	Rated I/O power supply voltage	Model
Inputs	NPN (+ common)	16 inputs	Sensor connector	Supplied from the communications connector	Supplied from the communications connector	DRT2-ID16S
	PNP (- common)					DRT2-ID16S-1
I/O	NPN (input: + common, output: - common)	8 inputs/ 8 outputs			Supplied from external source for outputs	DRT2-MD16S
	PNP (input: - common, output: + common)					DRT2-MD16S-1

General Specifications

Item	Model	DRT2-ID16S(-1)	DRT2-MD16S(-1)
Communications power supply voltage		11 to 25 VDC	
Unit power supply voltage		Not required (Supplied from the communications connector.)	
I/O power supply voltage		20.4 to 26.4 VDC (24 VDC -15%/+10%)	
Current consumption		Communications power supply: 230 mA max.	Communications power supply: 135 mA max.
Dielectric strength		500 VAC between isolated circuits	
Noise immunity		Conforms to IEC61000-4-4, 2 kV (power line)	
Vibration resistance		10 to 60 Hz, 0.7-mm double amplitude, 60 to 150 Hz, 50 m/s ² for 80 min each in the X, Y, and Z directions	
Shock resistance		150m/s ² , 6 directions, 3 times each	
Mounting method		DIN 35 mm-track mounting or M4 screw mounting	
Screw tightening torque		M2 (communications connector screws): 0.26 to 0.3 N·m M4 (unit mounting): 0.6 to 0.98 N·m	
Ambient operating temperature		-10°C to 55°C	
Ambient operating humidity		25 to 85% (with no condensation)	

Item	Model	DRT2-ID16S(-1)	DRT2-MD16S(-1)
Ambient storage temperature		-25°C to 65°C	
Weight		90 g max.	95 g max.

Output Specifications

● Terminals with 8 Inputs and 8 Outputs

Item	Model	DRT2-MD16S	DRT2-MD16S-1
Internal I/O common		NPN	PNP
I/O points		8 outputs (8 to 15)	
Rated output current		0.3 A/point, 2.4 A/common	0.3 A/point, 1.6 A/common
Residual voltage		1.2 VDC max. (0.3 A DC between output and G terminal)	1.2 VDC max. (0.3 A DC between output and V terminal)
Leakage current		0.1 mA max.	
ON delay time		1.5 ms max.	
OFF delay time		1.5 ms max.	
Number of circuits per common		8 per common	
Load short-circuit detection current		2.4 A min./common	1.6 A min./common

Input Specifications

● Terminals with 16 Inputs

Item	Model	DRT2-ID16S	DRT2-ID16S-1
Internal I/O common		NPN	PNP
I/O points		16 inputs	
ON voltage		9 VDC min. (between each input terminal and V)	9 VDC min. (between each input terminal and G)
OFF voltage		5 VDC max. (between each input terminal and V)	5 VDC max. (between each input terminal and G)
OFF current		1 mA max.	
Input current		11 mA max./point (at 24 VDC) 3.0 mA min./point (at 11 VDC)	
ON delay time		1.5 ms max.	
OFF delay time		1.5 ms max.	
Number of circuits per common		16 per common	
Sensor short-circuit detection current		The total current for all of the following input points is monitored to detect sensor short-circuits. IN0/IN1, IN2/IN3, IN4/IN5, IN6/IN7, IN8/IN9, IN10/IN11, IN12/IN13, IN14/IN15	

● Terminal with 8 Inputs/8 Outputs

Item	Model	DRT2-MD16S	DRT2-MD16S-1
Internal I/O common		NPN	PNP
I/O points		8 inputs (0 to 7)	
ON voltage		9 VDC min. (between each input terminal and V)	9 VDC min. (between each input terminal and G)
OFF voltage		5 VDC max. (between each input terminal and V)	5 VDC max. (between each input terminal and G)
OFF current		1 mA max.	
Input current		11 mA max./point (at 24 VDC) 3.0 mA min./point (at 11 VDC)	
ON delay time		1.5 ms max.	
OFF delay time		1.5 ms max.	
Number of circuits per common		8 per common	
Sensor short-circuit detection current		The total current for all of the following input points is monitored to detect sensor short-circuits. IN0/IN1, IN2/IN3, IN4/IN5, IN6/IN7	

Applicable Connectors (sold separately)

● OMRON Connectors

Model	Specifications	Compatible wire size
XN2A-1430	Spring-clamp style	28 to 20 AWG (0.08 to 0.5 mm ²) wire, 1.5 mm max. outer diameter including insulation

● Tyco Electronics Connectors

Model	Color of housing	Compatible wire size
3-1473562-4	Orange	0.6 to 0.9 mm max. outer diameter including insulation
1-1473562-4	Red	0.9 to 1.0 mm max. outer diameter including insulation
1473562-4	Yellow	1.0 to 1.15 mm max. outer diameter including insulation
2-1473562-4	Blue	1.15 to 1.35 mm max. outer diameter including insulation
4-1473562-4	Green	1.35 to 1.60 mm max. outer diameter including insulation

Wire size: 0.08 to 0.5 mm²

● Sumitomo 3M Connectors

Model	Specifications/color of housing	Compatible wire size
37104-3101-000FL	Red	26 to 24 AWG (0.14 to 0.2 mm ²) wire, 0.8 to 1.0 mm max. outer diameter including insulation
37104-3122-000FL	Yellow	26 to 24 AWG (0.14 to 0.2 mm ²) wire, 1.0 to 1.2 mm max. outer diameter including insulation
37104-3163-000FL	Orange	26 to 24 AWG (0.14 to 0.2 mm ²) wire, 1.2 to 1.6 mm max. outer diameter including insulation
37104-2124-000FL	Green	22 to 20 AWG (0.3 to 0.5 mm ²) wire, 1.0 to 1.2 mm max. outer diameter including insulation
37104-2165-000FL	Blue	22 to 20 AWG (0.3 to 0.5 mm ²) wire, 1.2 to 1.6 mm max. outer diameter including insulation
37104-2206-000FL	Gray	22 to 20 AWG (0.3 to 0.5 mm ²) wire, 1.6 to 2.0 mm max. outer diameter including insulation

Dimensions

(Unit: mm)

DRT2-ID16S(-1)

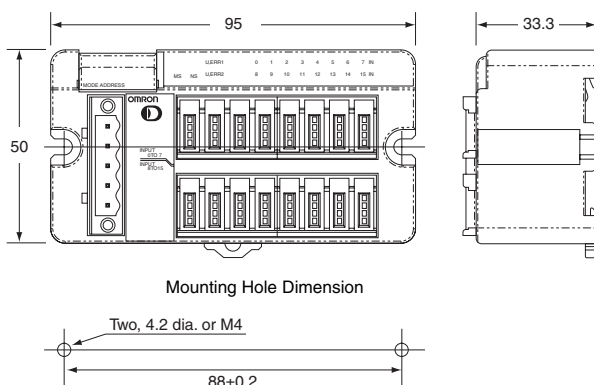

DRT2-MD16S(-1)

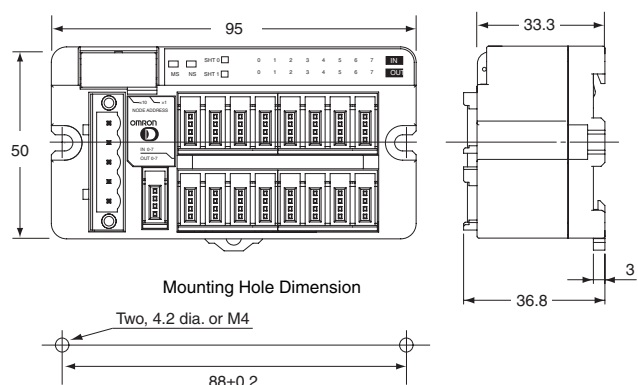

Wiring Diagrams

DRT2-ID16S (NPN)

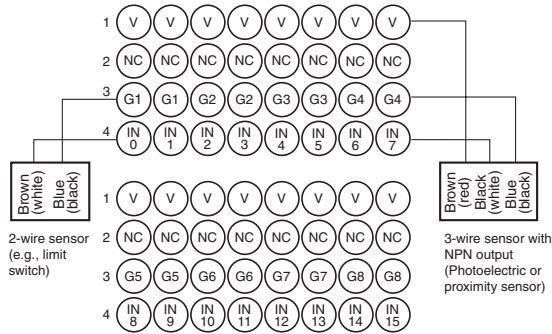

DRT2-ID16S-1 (PNP)

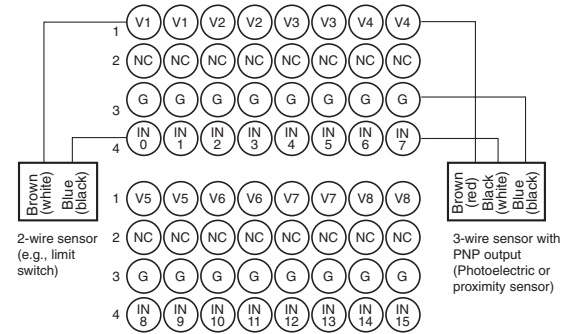

DRT2-MD16S (NPN)

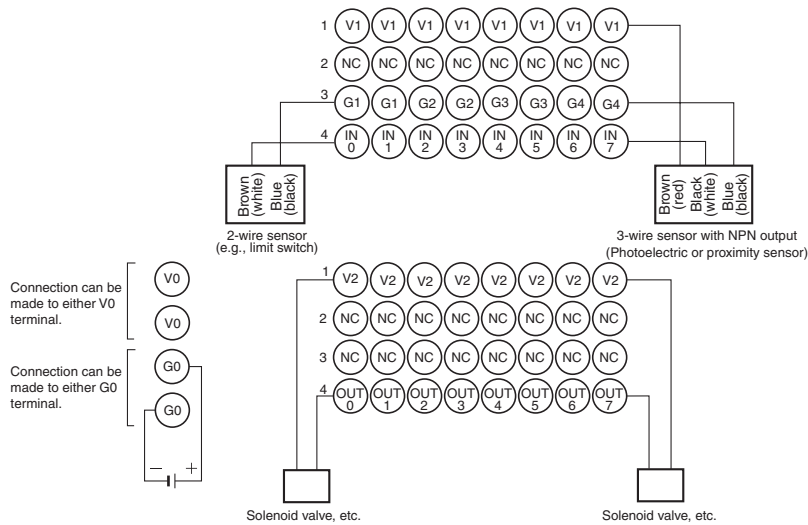

DRT2-MD16S-1 (PNP)

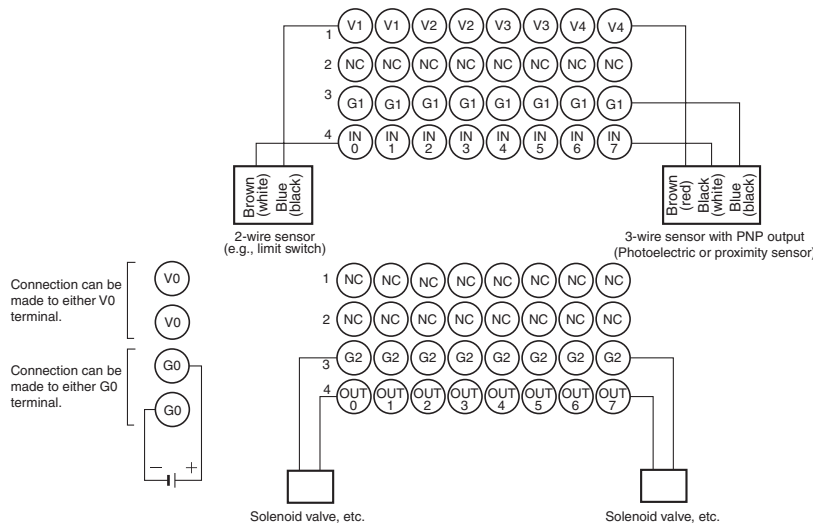

Read and Understand This Catalog

Please read and understand this catalog before purchasing the products. Please consult your OMRON representative if you have any questions or comments.

Warranty and Limitations of Liability

WARRANTY

OMRON's exclusive warranty is that the products are free from defects in materials and workmanship for a period of one year (or other period if specified) from date of sale by OMRON.

OMRON MAKES NO WARRANTY OR REPRESENTATION, EXPRESS OR IMPLIED, REGARDING NON-INFRINGEMENT, MERCHANTABILITY, OR FITNESS FOR PARTICULAR PURPOSE OF THE PRODUCTS. ANY BUYER OR USER ACKNOWLEDGES THAT THE BUYER OR USER ALONE HAS DETERMINED THAT THE PRODUCTS WILL SUITABLY MEET THE REQUIREMENTS OF THEIR INTENDED USE. OMRON DISCLAIMS ALL OTHER WARRANTIES, EXPRESS OR IMPLIED.

LIMITATIONS OF LIABILITY

OMRON SHALL NOT BE RESPONSIBLE FOR SPECIAL, INDIRECT, OR CONSEQUENTIAL DAMAGES, LOSS OF PROFITS OR COMMERCIAL LOSS IN ANY WAY CONNECTED WITH THE PRODUCTS, WHETHER SUCH CLAIM IS BASED ON CONTRACT, WARRANTY, NEGLIGENCE, OR STRICT LIABILITY.

In no event shall the responsibility of OMRON for any act exceed the individual price of the product on which liability is asserted.

IN NO EVENT SHALL OMRON BE RESPONSIBLE FOR WARRANTY, REPAIR, OR OTHER CLAIMS REGARDING THE PRODUCTS UNLESS OMRON'S ANALYSIS CONFIRMS THAT THE PRODUCTS WERE PROPERLY HANDLED, STORED, INSTALLED, AND MAINTAINED AND NOT SUBJECT TO CONTAMINATION, ABUSE, MISUSE, OR INAPPROPRIATE MODIFICATION OR REPAIR.

Application Considerations

SUITABILITY FOR USE

OMRON shall not be responsible for conformity with any standards, codes, or regulations that apply to the combination of products in the customer's application or use of the products.

At the customer's request, OMRON will provide applicable third party certification documents identifying ratings and limitations of use that apply to the products. This information by itself is not sufficient for a complete determination of the suitability of the products in combination with the end product, machine, system, or other application or use.

The following are some examples of applications for which particular attention must be given. This is not intended to be an exhaustive list of all possible uses of the products, nor is it intended to imply that the uses listed may be suitable for the products:

- Outdoor use, uses involving potential chemical contamination or electrical interference, or conditions or uses not described in this catalog.
- Nuclear energy control systems, combustion systems, railroad systems, aviation systems, medical equipment, amusement machines, vehicles, safety equipment, and installations subject to separate industry or government regulations.
- Systems, machines, and equipment that could present a risk to life or property.

Please know and observe all prohibitions of use applicable to the products.

NEVER USE THE PRODUCTS FOR AN APPLICATION INVOLVING SERIOUS RISK TO LIFE OR PROPERTY WITHOUT ENSURING THAT THE SYSTEM AS A WHOLE HAS BEEN DESIGNED TO ADDRESS THE RISKS, AND THAT THE OMRON PRODUCTS ARE PROPERLY RATED AND INSTALLED FOR THE INTENDED USE WITHIN THE OVERALL EQUIPMENT OR SYSTEM.

PROGRAMMABLE PRODUCTS

OMRON shall not be responsible for the user's programming of a programmable product, or any consequence thereof.

Disclaimers

CHANGE IN SPECIFICATIONS

Product specifications and accessories may be changed at any time based on improvements and other reasons.

It is our practice to change model numbers when published ratings or features are changed, or when significant construction changes are made. However, some specifications of the products may be changed without any notice. When in doubt, special model numbers may be assigned to fix or establish key specifications for your application on your request. Please consult with your OMRON representative at any time to confirm actual specifications of purchased products.

DIMENSIONS AND WEIGHTS

Dimensions and weights are nominal and are not to be used for manufacturing purposes, even when tolerances are shown.

PERFORMANCE DATA

Performance data given in this catalog is provided as a guide for the user in determining suitability and does not constitute a warranty. It may represent the result of OMRON's test conditions, and the users must correlate it to actual application requirements. Actual performance is subject to the OMRON Warranty and Limitations of Liability.

ERRORS AND OMISSIONS

The information in this document has been carefully checked and is believed to be accurate; however, no responsibility is assumed for clerical, typographical, or proofreading errors, or omissions.

2012.5

In the interest of product improvement, specifications are subject to change without notice.

OMRON Corporation
Industrial Automation Company

<http://www.ia.omron.com/>

(c)Copyright OMRON Corporation 2012 All Right Reserved.