

Modular Temperature Controller E5ZN

CSM_E5ZN_DS_E_3_1

New DIN Track Mounting Temperature Controller

- Two channels of temperature control available despite width of only 22.5 mm.
- The Temperature Controller itself can be replaced without changing terminal wiring.
- Use in combination with a compact Setting Display Unit to reduce communications programming requirements.
- Front-panel LED indicators for easy operation monitoring.
- Power supply and communications wiring not required between Units when mounted side-by-side.
- CompoWay/F communications protocol supported.
- UL, CSA, and CE Marking compliance.



Refer to *Safety Precautions* on page 11 to 12 and *Safety Precautions for All Temperature Controllers*.

Model Number Structure

■ Model Number Legend

E5ZN-□□□□□□-□

1234567

1. Control points

2: Two points

2. Control output

Q: Voltage (for driving SSR)

T: Transistor

C: Current

3. Auxiliary output

P: Two sourcing transistor outputs

N: Two sinking transistor outputs

4. Option

H: Heater burnout alarm

F: Transfer output (See note 1.)

5. Communications

03: RS-485

6. Input type

TC: Thermocouple

P: Platinum resistance thermometer

7. CompoWay/F serial communications

FLK: CompoWay/F serial communications

Note: 1. Transfer output can be specified only when the control output is a current output.

2. The above model number legend is intended as a functional description of models. Not all possible combinations of functions are available. Confirm model availability in *Ordering Information* on page 2 when ordering.

Example: Voltage output, two sinking transistor outputs, heater burnout alarm, thermocouple: E5ZN-2TNH03TC-FLK

Note: Be sure to read the precautions for correct use and other precautions in the following user's manual before using the Digital Controller.

E5ZN Modular Temperature Controller User's Manual (Cat. No. H113)

Ordering Information

List of Models

Name	Power supply	No. of control points	Control output	Auxiliary output	Functions	Communications functions	Input type (See note 5.)	Model	
Temperature Controller (See note 1.)	24 VDC	2	Voltage output (for SSRs)	Transistor output: 2 pts (sinking)	Heater burnout alarm (See note 3.)	RS-485	Thermocouple	E5ZN-2QNH03TC-FLK	
				Transistor output: 2 pts (sourcing)			Platinum resistance thermometer	E5ZN-2QNH03P-FLK	
				Transistor output			Transistor output: 2 pts (sinking)	Thermocouple	E5ZN-2QPH03TC-FLK
							Transistor output: 2 pts (sourcing)	Platinum resistance thermometer	E5ZN-2QPH03P-FLK
			Analog output (current output) (See note 2.)	Transistor output: 2 pts (sinking)	Thermocouple		E5ZN-2TNH03TC-FLK		
				Transistor output: 2 pts (sourcing)	Platinum resistance thermometer		E5ZN-2TNH03P-FLK		
			Transfer output (linear voltage output) (See note 2.)	Transistor output: 2 pts (sinking)	Thermocouple		E5ZN-2TPH03TC-FLK		
				Transistor output: 2 pts (sourcing)	Platinum resistance thermometer		E5ZN-2TPH03P-FLK		
				Transfer output (linear voltage output) (See note 2.)	Thermocouple		E5ZN-2CNF03TC-FLK		
					Platinum resistance thermometer		E5ZN-2CNF03P-FLK		
			Thermocouple	E5ZN-2CPF03TC-FLK					
			Platinum resistance thermometer	E5ZN-2CPF03P-FLK					

- Note:**
- Terminal Units are required for wiring. Purchase separately.
 - When connecting the load of the controlled system, heat control output or cool control output can be allocated to the control output or auxiliary output. When connecting a recording device or Digital Panel Meter, transfer output can be allocated to control output or auxiliary output 3 or 4 of analog output models.
 - When using the heater burnout alarm, purchase a Current Transformer (E54-CT1 or E54-CT3) separately.
 - When using heating and cooling control functionality, the auxiliary output will be either heating control output or cooling control output.
 - Analog input and infrared temperature sensors (ES1B) can also be used with thermocouple models.

Terminal Unit

Name	No. of terminals	Functions	Model
Terminal Unit (Includes bus system without backplane.)	24	Equipped with communications terminals for power supply, communications, and setting devices.	E5ZN-SCT24S-500
	18 (See note 1.)	Not equipped with communications terminals for power supply, communications, and setting devices.	E5ZN-SCT18S-500

- Note:**
- When using 2 or more E5ZNs mounted side-by-side, use the E5ZN-SCT18S-500 for the second and subsequent Units. When using E5ZNs separately, be sure to use the E5ZN-SCT24S-500.
 - Two End Plates are provided with a E5ZN-SCT24S-500 Terminal Unit. Up to 16 Terminal Units can be used to expand the system to a maximum of 32 channels. When mounting to a DIN Track, be sure to mount End Plates on both sides.

Accessories (Order Separately)

Terminal Cover

Model	E53-COV12	E53-COV13
Type	For SCT24S-500 models	For SCT18S-500 models

Current Transformer (CT)

Model	E54-CT1	E54-CT3
Diameter	5.8 dia.	12.0 dia.

Sockets (for Setting Display Unit - Order Separately)

Model	P2CF-11	P2CF-11-E	P3GA-11	Y92A-48G
Type	Front-connecting socket	Front-connecting socket (with finger protection)	Back-connecting socket	Terminal cover for finger protection

Note: Refer to the following manual for precautionary information and other information necessary to use the E5ZN: E5ZN Temperature Controller Operation Manual (Cat. No. H113).

Setting Display Unit

Name	Power supply	Model
Setting Display Unit (See note.)	24 VDC	E5ZN-SDL

Note: Purchase sockets for wiring (shown on page 2) separately.

Specifications

Ratings

Power supply voltage	24 VDC	
Allowable voltage range	85% to 110% of the rated power supply voltage	
Power consumption	Approx. 3 W	
Sensor input	Thermocouple: K, J, T, E, L, U, N, R, S, B Infrared temperature sensor (ES1B series): 10 to 70°C, 60 to 120°C, 115 to 165°C, 140 to 260°C Voltage input: 0 to 50 mV Platinum resistance thermometer: Pt100, JPt100	
Control output	Voltage output (for driving SSR)	Output voltage: 12 VDC ±15% (PNP); Maximum load current: 21 mA; Equipped with short-circuit protection circuit
	Transistor output	Maximum operational voltage: 30 VDC; Maximum load current: 100 mA; Residual voltage: 1.5 V max.; Leakage current: 0.4 mA max.
	Current output	Current output range: 4 to 20/0 to 20 mA DC; Load: 350 Ω max. (See note 2.)
Auxiliary output	Transistor output	Sourcing Maximum operating voltage: 30 VDC; Maximum load current: 50 mA; Residual voltage: 1.5 V max.; Leakage current: 0.4 mA max.
		Sinking Maximum operating voltage: 30 VDC; Maximum load current: 50 mA; Residual voltage: 1.5 V max.; Leakage current: 0.4 mA max.
Event input	Linear voltage output	Voltage output range: 1 to 5/0 to 5 VDC; Load: 10 kΩ min.
	Contact output	ON: 1 kΩ max., OFF: 100 kΩ min. Discharge current: Approx. 7 mA
	Non-contact output	ON: Residual voltage: 1.5 V max., OFF: Leakage current: 0.1 mA max. Discharge current: Approx. 7 mA
Number of input and control points	Input points: 2, Control points: 2	
Setting method	Via communications or using the Setting Display Unit (E5ZN-SDL)	
Control method	2-PID or ON/OFF control	
Other functions	Heater burnout detection function, transfer output function Multi-SP and RUN/STOP switching using event input	
Ambient operating temperature	-10 to 55°C (with no icing or condensation) For 3 years of assured use: -10 to 50°C	
Ambient operating humidity	25% to 85%	
Storage temperature	-25 to 65°C (with no icing or condensation)	

Note: 1. Do not use an inverter output for the power supply. (Refer to *Safety Precautions for All Temperature Controllers*.)
2. OMRON G32A-EA Cycle Controller Unit (load impedance 352 Ω) can be used.

Input Range

Platinum Resistance Thermometer Models and Thermocouple Models

Input type	Platinum resistance thermometer models		Thermocouple models													Analog input 0 to 50 mV											
	Platinum resistance thermometer		Thermocouple										Infrared temperature sensor														
	Name	Pt100	JPt100	K	J	T	E	L	U	N	R	S	B	10 to 70°C	60 to 120°C		115 to 165°C	140 to 260°C									
Temperature range (°C)	1800												1700	1700	1800										-1999 to 9999 or -199.9 to 999.9 by scaling		
	1700																										
	1600																										
	1500																										
	1400																										
1300																											
1200																											
1100																											
1000																											
900																											
800																											
700																											
600																											
500																											
400																											
300																											
200																											
100																											
0																											
-100																											
-200																											
Setting number	0	1	2	3	4	0	1	2	3	4	17	5	6	7	18	8	9	10	11	12	13	14	15	16			

The applicable standards for the input types are as follows:

- K, J, T, E, N, R, S, B: JIS C1602-1995, IEC584-1
- L: Fe-CuNi, DIN 43710-1985
- U: Cu-CuNi, DIN 43710-1985
- JPt100: JIS C 1604-1989, JIS C 1606-1989
- Pt100: JIS C 1604-1997 IEC 751

Shaded parts indicate the settings at the time of purchase.

■ Characteristics

Indication accuracy	Thermocouple: (Indicated value $\pm 0.5\%$ or $\pm 1^\circ\text{C}$, whichever is greater) ± 1 digit max. (See note 1.) Platinum resistance thermometer: (Indicated value $\pm 0.5\%$ or $\pm 1^\circ\text{C}$, whichever is greater) ± 1 digit max. (See note 1.) Analog input: $\pm 0.5\%$ or ± 1 digit max. CT input: $\pm 5\%$ FS ± 1 digit max.
Influence of temperature	Thermocouple input (R, S, B): ($\pm 1\%$ of PV or $\pm 10^\circ\text{C}$, whichever is greater) ± 1 digit max. Other thermocouple input: ($\pm 1\%$ of PV or $\pm 4^\circ\text{C}$, whichever is greater) ± 1 digit max. *K thermocouple at -100°C max.: $\pm 10^\circ\text{C}$ max.
Influence of voltage	Platinum resistance thermometer: ($\pm 1\%$ of PV or $\pm 2^\circ\text{C}$, whichever is greater) ± 1 digit max. Analog input: ($\pm 1\%$ FS) ± 1 digit max.
Transfer output	Accuracy: $\pm 0.5\%$ FS (See note 2.)
Hysteresis	0.1 to 999.9 EU (in units of 0.1 EU) (See note 3.)
Proportional band (P)	0.1 to 999.9 EU (in units of 0.1 EU) (See note 3.)
Integral time (I)	0 to 3,999 s (in units of 1 s)
Derivative time (D)	0 to 3,999 s (in units of 1 s)
Control period	1 to 99 s (in units of 1 s)
Manual reset value	0.0 to 100.0% (in units of 0.1%)
Alarm setting range	-1,999 to 9,999 (Position of decimal point depends on input type.)
Sampling period	500 ms
Insulation resistance	20 M Ω min. (at 500 VDC)
Dielectric strength	600 VAC for 1 minute at 50 or 60 Hz (between unlike terminals of charged parts)
Vibration resistance	10 to 55 Hz, 10 m/s ² for 2 h each in X, Y, and Z directions
Shock resistance	150 m/s ² max., 3 times each in $\pm X$, $\pm Y$, and $\pm Z$ directions
Weight	Temperature Controller: Approx. 90 g Terminal Unit (18): Approx. 80 g Terminal Unit (24): Approx. 100 g
Degree of protection	Temperature Controller: IP00 Terminal Unit: IP00
Memory protection	EEPROM (non-volatile memory) (Number of write operations: 100,000)
Approved standards (See note 4.)	UL File No.: E200593 CSA File No.: 203889-1140084 CE EMS: ESD EN61326, EN61000-4-2 (4 kV/contact, 8 kV/air) REM field EN61326, EN61000-4-3 (10 V/m) Fast transient EN61326, EN61000-4-4 (2 kV/DC power, 1 kV/I/O) Surge immunity EN61326, EN61000-4-5 (line to ground: 2 kV/DC power 1 kV/I/O line to line: 1 kV/DC power) Conducted RF EN61326, EN61000-4-6 (10 V) EMI: Radiated EN61326 Class A

Note: 1. The indication accuracy for T and N thermocouples at -100°C , and for U and L thermocouples is $\pm 2^\circ\text{C} \pm 1$ digit max. There is no specification for the indication accuracy for the B thermocouple used at 400°C max. The indication accuracy for R and S thermocouples at 200°C max. is $\pm 3^\circ\text{C} \pm 1$ digit max.

2. The transfer output accuracy for 0 to 4 mA when 0 to 20 mA DC is selected is $\pm 0.5\%$ FS $+0.7$ mA. The transfer output accuracy for 0 to 1 V when 0 to 5 VDC is selected is $\pm 0.5\%$ FS $+0.175$ V.

3. "EU" stands for "Engineering Unit."

4. In order to satisfy the EN61326 Class A standard for conducted emissions, install a noise filter (Densei-Lambda MXB-1206-33 or equivalent) in a DC power line as close to the E5ZN as possible.

■ Communications (Host Communications)

Transmission line connection method	RS-485 multipoint
Communications method	RS-485 (2-wire, half-duplex)
Synchronization method	Start-stop synchronization
Baud rate	4,800, 9,600, 19,200, or 38,400 bps
Transmission code	ASCII
Data bit length (See note.)	7 or 8 bits
Stop bit length (See note.)	1 or 2 bits
Error detection	Vertical parity (none, even, odd)
	BCC (block check character)
Flow control	None
Interface	RS-485
Retry function	None
Number of Units that can be connected in parallel	16 Units max. (32 channels)

Note: The baud rate, data bit length, stop bit length, and vertical parity can all be set independently as host communications settings.

□ : Default setting values

■ Setting Display Unit (Order Separately)

Power supply voltage	24 VDC
Allowable voltage range	85% to 110% of the rated power supply voltage
Power consumption	Approx. 1 W
Display method	7-segment digital display and single-color display
Ambient operating temperature	-10 to 55°C (with no icing or condensation) For 3 years of assured use: -10 to 50°C
Ambient operating humidity	25% to 85%
Storage temperature	-25 to 65°C (with no icing or condensation)
Communications method	RS-485 (half-duplex)
Communications format	Special protocol
Insulation resistance	20 MΩ min. (at 500 VDC)
Dielectric strength	1,500 VAC for 1 minute at 50 or 60 Hz (between unlike terminals of charged parts)
Vibration resistance	10 to 55 Hz, 20 m/s ² for 2 h each in X, Y, and Z directions
Shock resistance	300 m/s ² max., 3 times each in ±X, ±Y, and ±Z directions
Enclosure ratings	Front panel: IP50 Rear case: IP20 Terminal case: IP00
Memory protection	EEPROM (non-volatile memory) (Number of writes: 100,000)
Weight	Approx. 100 g Mounting bracket: Approx. 10 g

■ Current Transformer (CT) (Order Separately)

Dielectric strength	1,000 VAC (1 minute)
Vibration resistance	50 Hz, 98 m/s ²
Weight	E54-CT1: Approx. 11.5 g E54-CT3: Approx. 50 g
Accessories (E54-CT3 only)	Armature (2) Plug (2)

■ Heater Burnout Alarm

Maximum heater current	Single-phase, 50 A AC (See note 1.)
Input current readout accuracy	±5% FS ±1 digit max.
Heater burnout alarm setting range	0.0 to 50.0 A (in units of 0.1 A) (See note 2.)
Minimum detection ON time	190 ms (See note 3.)

- Note:**
1. Use the K8AC-H Digital Heater Burnout Alarm Detector for burnout detection of 3-phase heaters.
 2. If the heater burnout alarm setting is set to 0.0 A, the alarm is always OFF, and if it is set to 50.0 A the alarm is always ON.
 3. If the ON time for control output is less than 190 ms, heater burnout detection and heater current measurement will not be performed.

Installation

■ Connection Diagrams

- Voltage output (control output) is not electrically isolated from internal circuitry. Therefore, when using grounded thermocouples, do not ground control output terminals. (Doing so may result in temperature measurement errors due to unwanted current paths.)
- There is basic insulation between the power supply inputs and outputs for this product. If reinforced insulation is required, connect the input and output terminals to equipment without any exposed charge-carrying parts, or to equipment with basic insulation sufficient for the maximum operating voltage of the power supply and the inputs and outputs.
- To comply with the standards for noise terminal voltage for class A in EN 61326, install a noise filter (Densei Lamda MXB-1206-33 or the equivalent) to the DC power line as close as possible to the Temperature Controller.

Using with the E5ZN-SCT24S-500

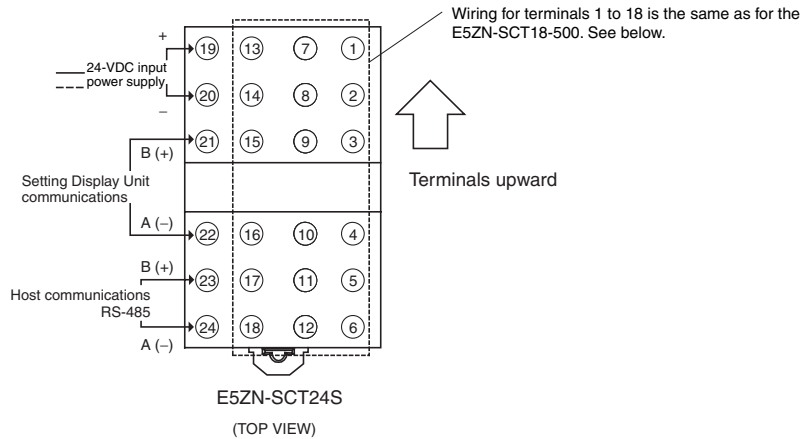

Using with the E5ZN-SCT18S-500

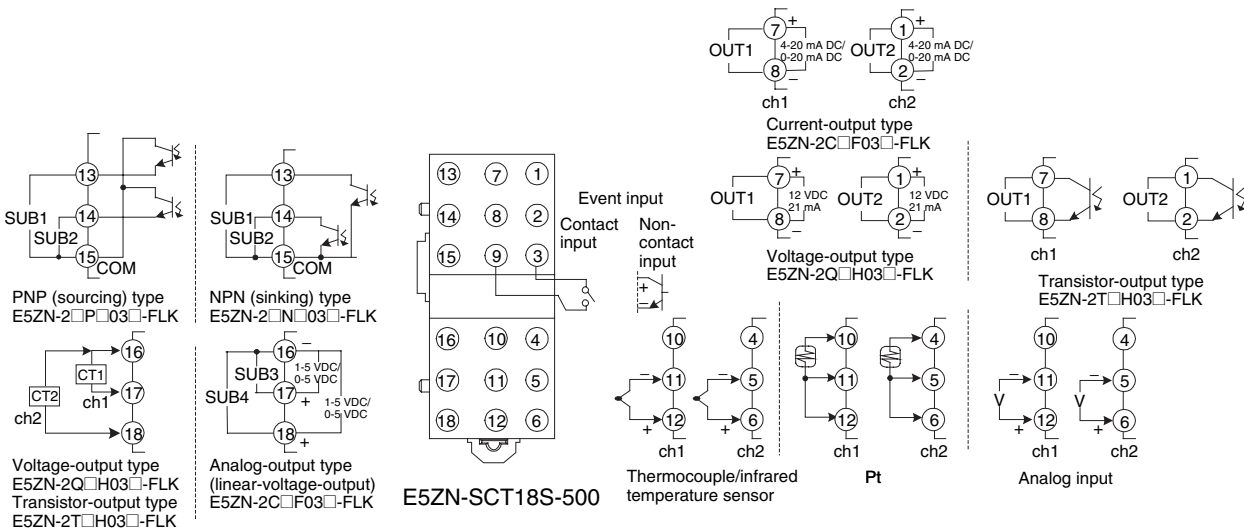

E5ZN-SDL

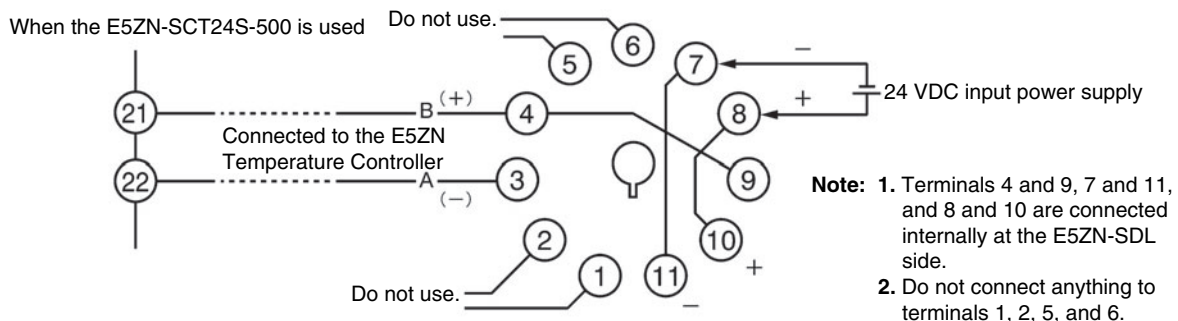

Note: Purchase either a P2CF-11 or a P3GA-11 Socket separately. (Refer to pages 10 to 11.)

Nomenclature

E5ZN-2

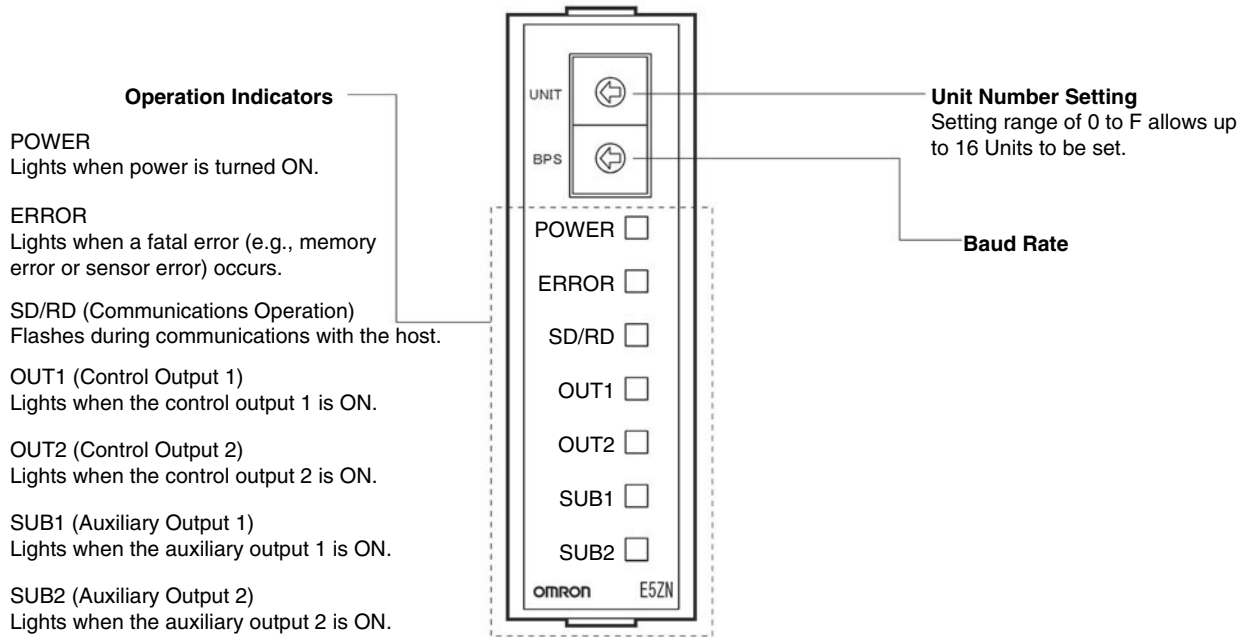

E5ZN-SDL

The following diagram shows the names and functions of the E5ZN-SDL parts for when it is connected to the E5ZN-2□□□□□□□□.

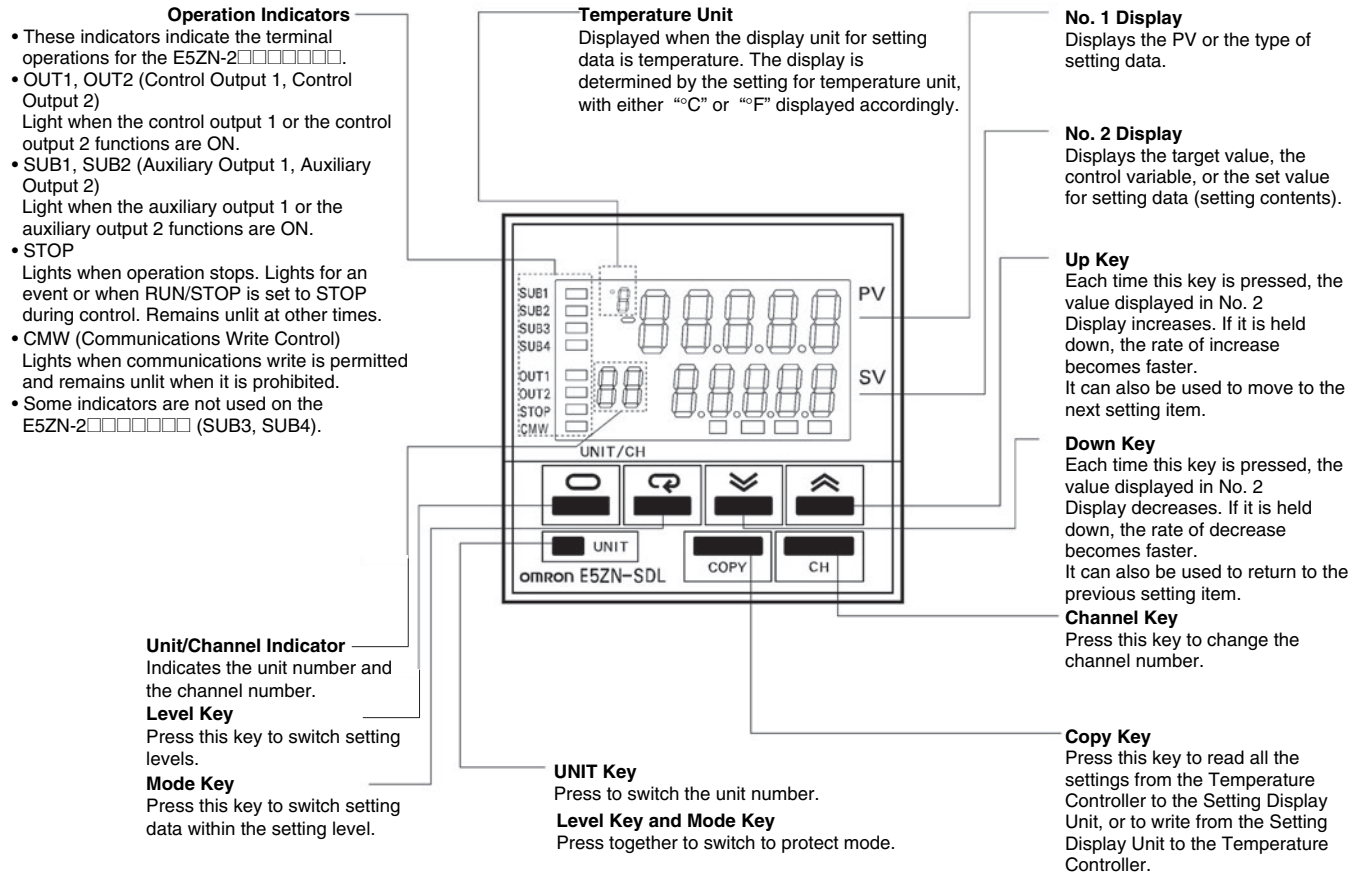

Dimensions

Note: All units are in millimeters unless otherwise indicated.

E5ZN-2□□□03□-FLK Connected to E5ZN-SCT24S-500

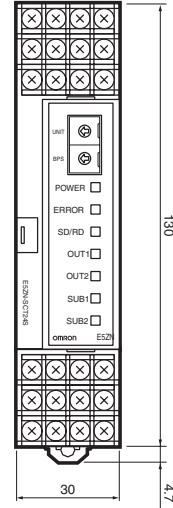
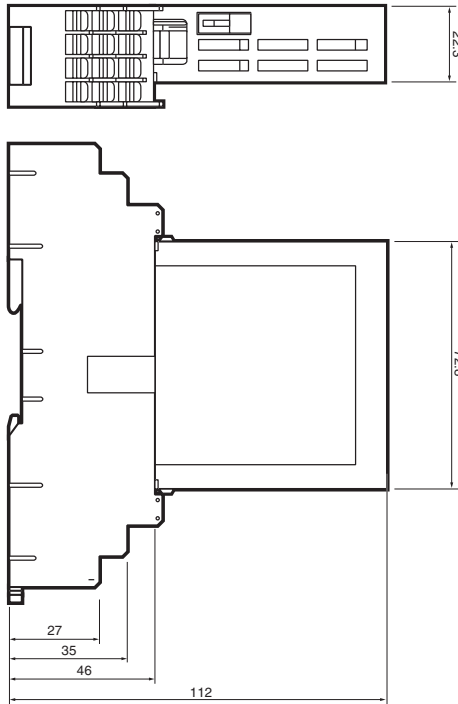
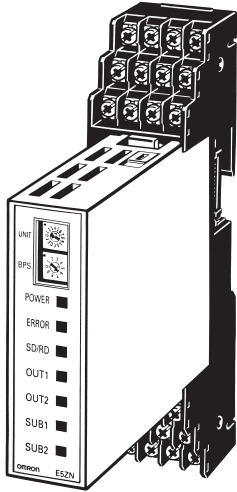

When only using one Unit, purchase the E5ZN-2□□□03□-FLK and the E5ZN-SCT24S-500 together. Also, when using horizontal side-by-side mounting, purchase the first Unit together with the E5ZN-SCT24S-500.

E5ZN-2□□□03□-FLK Connected to E5ZN-SCT18S-500

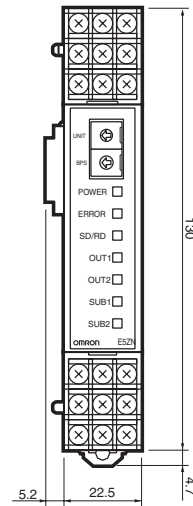
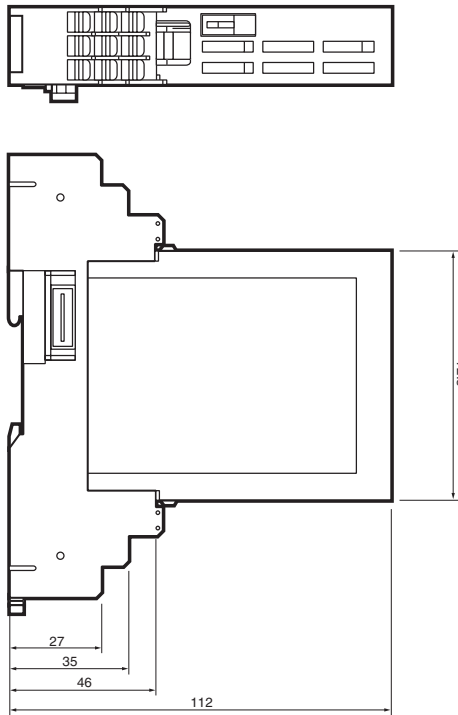
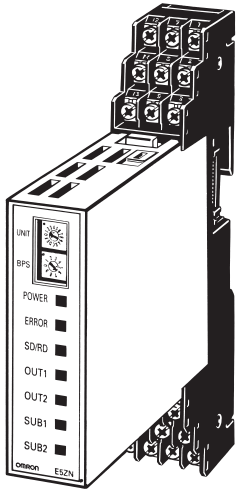

When mounting Units side-by-side, purchase the E5ZN-2□□□03□-FLK together with the E5ZN-SCT18S-500 for the second and subsequent Units.

■ End Plate

PFP-M

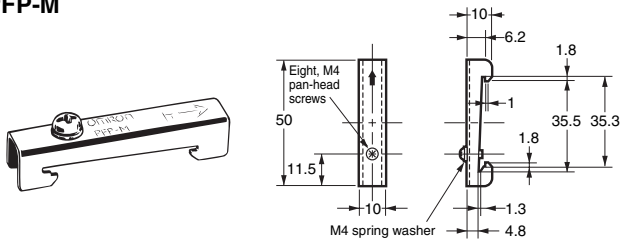

Note: End Plates are provided with the E5ZN-SCT24-500. Be sure to mount End Plates at both ends of Unit blocks.

■ Current Transformer (Order Separately)

E54-CT1

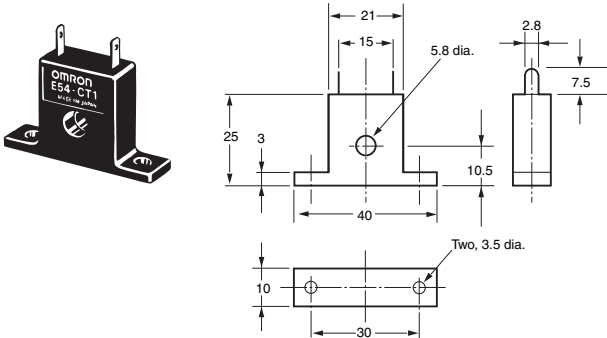

E54-CT3

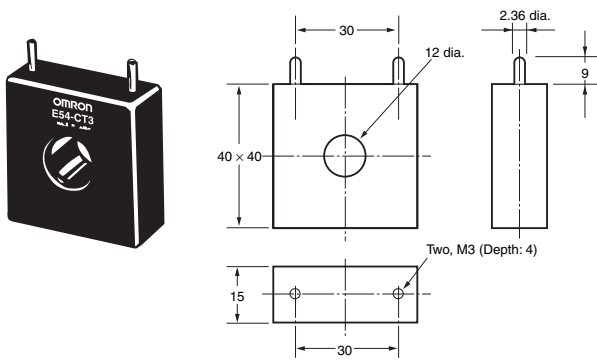

E54-CT3 Accessories Connection Example

• Armature

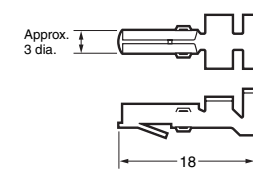

• Plug

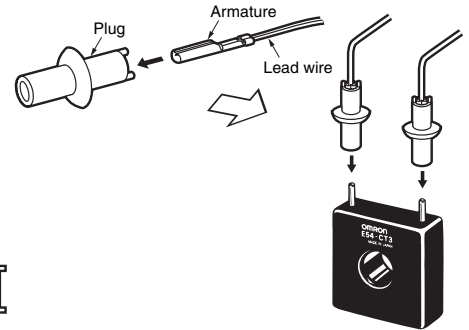
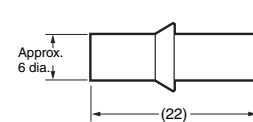

■ Terminal Cover (Order Separately)

E53-COV12

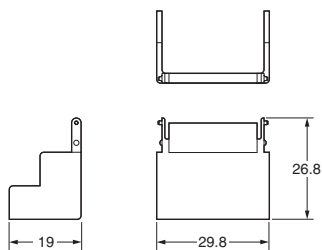

E53-COV13

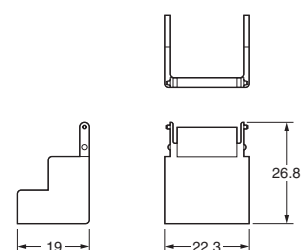

■ Rail Mounting Equipment (Order Separately)

Spacer

PFP-S

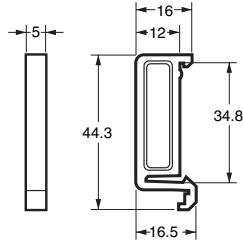
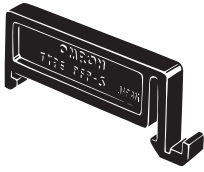

Mounting Track

PFP-100N

PFP-50N

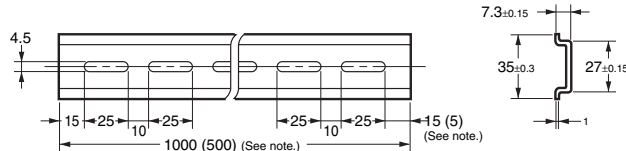
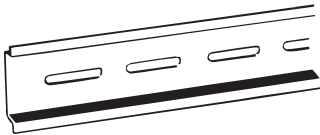

Note: The figures in parentheses are dimensions for the PFP-50N.

■ Setting Display Unit

E5ZN-SDL

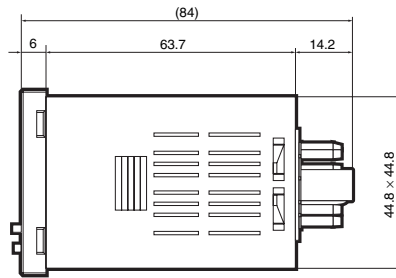
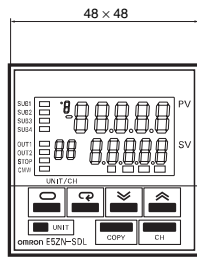

Panel Cutout Dimensions

Individual Mounting

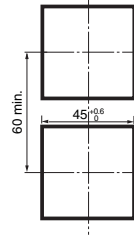

Side-by-side Mounting

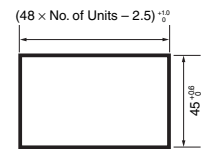

- The mounting panel thickness is 1 to 5 mm.
- Vertical side-by-side mounting is not possible. (Allow sufficient space above and below.)
- When mounting several Units, make sure that the ambient temperature specifications are not exceeded.

■ E5ZN-SDL Wiring Sockets

Front-connecting Sockets

P2CF-11 (Standard Model)

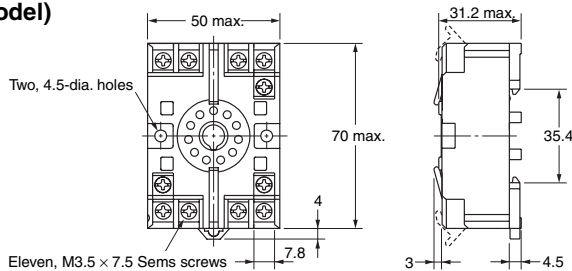
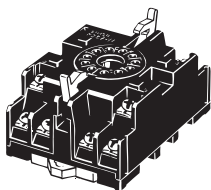

Terminal Arrangement/ Internal Connections

(TOP VIEW)

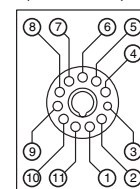

Mounting Hole Cutout Dimensions

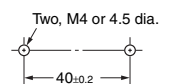

Note: DIN track mounting is also possible.

P2F-11-E (with Finger Protection)

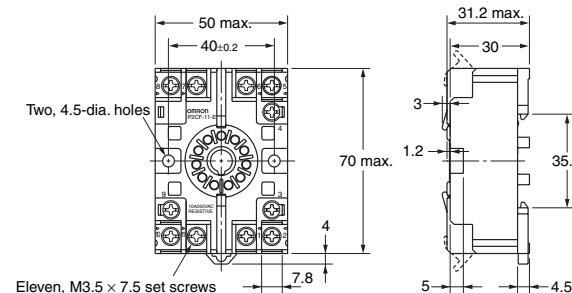
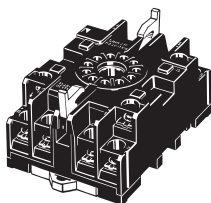

Back-connecting Sockets

P3GA-11 (Standard Model)

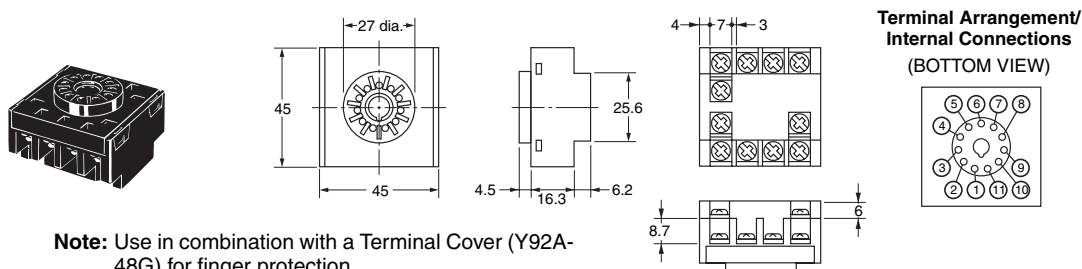

Note: Use in combination with a Terminal Cover (Y92A-48G) for finger protection.

Terminal Cover

Y92A-48G

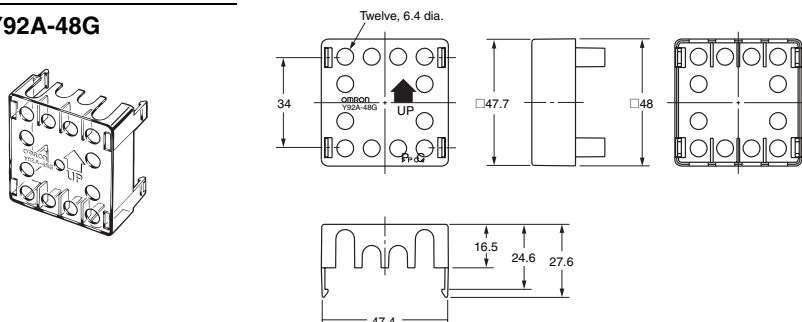

Safety Precautions

Refer to *Safety Precautions for All Temperature Controllers*.

⚠ WARNING

Provide at least one power-interruption switch to ensure that the power is OFF before wiring. Not doing so may result in electric shock.



■ Safety Precautions

Observe the following points to ensure safe operation.

- Use and store the product within the specified temperature and humidity ranges. Cool the product (e.g., using fans) where necessary.
- Do not touch the electronic components or pattern of the PCB. Hold the product by the case.
- To ensure proper heat dissipation, leave a space around the product. Do not block the product's ventilating holes.
- Use at the rated power supply voltage with the rated load.
- Be sure to connect terminals with the correct polarity.
- Perform wiring using crimp terminals of the specified size. (E5ZN-SCT□S-500: M3.0, width 5.8 mm max.; E5ZN-SDL: M3.5, width 7.2 max.)
- Be sure to use wires satisfying the following specifications for connection using bare wires.
 - Power supply terminals: AWG 22 to 14
 - Other terminals: AWG 28 to 16
 - (Length of exposed part: 6 to 8 mm)
- Do not connect anything to unused terminals.
- Ensure that the rated voltage is reached within 2 seconds of turning power ON.
- Allow 30 seconds' warm-up time.
- Install the product as far away as possible from devices that generate strong, high-frequency noise and devices that generate surges.
- Keep wiring separate from high-voltage power lines or power lines carrying large currents. Do not wire in parallel with or together with power lines.
- Install switches or circuit-breakers so that the user can turn the power OFF immediately, and indicate these accordingly.
- Do not use the product in the following locations:
 - Locations subject to dust or corrosive gases (in particular, sulfide gas and ammonia gas)
 - Locations subject to freezing or condensation
 - Locations exposed to direct sunlight
 - Locations subject to vibrations or shocks
 - Locations subject to exposure to water or oil
 - Locations subject to heat radiated directly from heating equipment
 - Locations subject to intense temperature changes
- When the Terminal Unit is separated from the Temperature Controller, under no circumstances touch the electrical components or apply shock to the Temperature Controller.
- Do not use solvents to clean the product. Use commercial alcohol.
- After wiring is completed remove the dust-protection label to allow proper heat dissipation.
- When mounting the Temperature Controller to the Terminal Unit, make sure that the hook on the side of the Temperature Controller facing the Terminal Unit is inserted properly.
- Install the DIN track vertically.

■ Precautions for Correct Use

Service Life

Use within the following temperature and humidity ranges:

- Temperature: -10 to 55°C (with no icing or condensation)
- Humidity: 25% to 85%

If the product is installed inside a control panel, the temperature around the product (and not the temperature around the control panel) must be kept below 55°C.

With electronic devices like the E5ZN, the service life will depend not only on the number of switching operations performed by the relay but also on the service life of the internal electronic components. The service life of these components depends on the ambient temperature; it will be shorter if the ambient temperature is high, and longer if the ambient temperature is low. For this reason, the service life of the product can be lengthened by keeping the inside of the E5ZN at a low temperature.

If several Units are mounted side-by-side or are arranged vertically, the heat generated may cause the internal temperature of the Units to rise, reducing service life. To prevent this, take steps to ensure that the Units are cooled, such as installing fans.

Ensure, however, that the terminals are not also cooled, otherwise correct temperature measurement will not be possible.

Measurement Accuracy

When extending the lead wires for thermocouples, use a compensating conductor appropriate for the type of thermocouple used.

When extending the lead wires for platinum resistance thermometers, use lead wires with a low resistance, and make the resistance in the 3 lead wires equal.

Make sure that the temperature sensor type and the input type of the E5ZN are the same.

Mount the E5ZN horizontally.

If significant errors occur, check that input compensation has been set correctly.

Waterproofing

The degree of protection is given below. Parts for which the degree of protection is not clearly indicated, and parts with IP□0 ratings (where □ is not 0) do not have waterproof specifications.

- Temperature Controller: IP00
- Terminal Unit: IP00

Operating Precautions

1. A time of approximately 4 s is required after the power supply is turned ON until the outputs turn ON. Take this time into consideration when the Temperature Controller is incorporated in a sequence circuit.
2. Using the product near radios, televisions, or other wireless devices may result in reception interference.

Mounting and Dismounting

- To mount using a mounting track, first hook part A (see below) onto the track and then push down on part B.

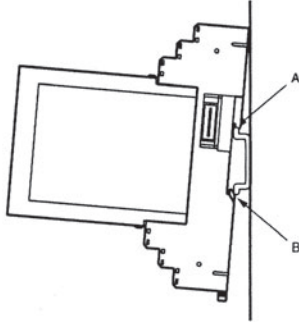

- To dismount, insert a flat-bladed screwdriver into part C, pull the hook down, and then lift the bottom part of the E5ZN upwards.

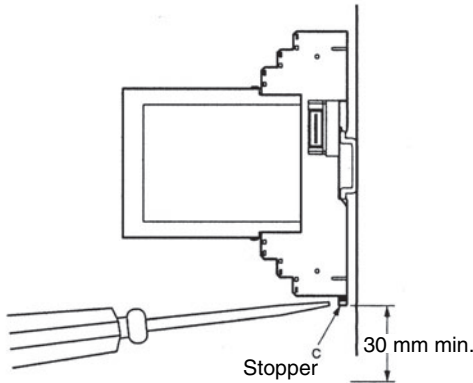

- Mount the E5ZN at least 30 mm away from other devices to ensure easy mounting and dismounting.

ALL DIMENSIONS SHOWN ARE IN MILLIMETERS.
 To convert millimeters into inches, multiply by 0.03937. To convert grams into ounces, multiply by 0.03527.

In the interest of product improvement, specifications are subject to change without notice.

Terms and Conditions of Sale

1. **Offer; Acceptance.** These terms and conditions (these "Terms") are deemed part of all quotes, agreements, purchase orders, acknowledgments, price lists, catalogs, manuals, brochures and other documents, whether electronic or in writing, relating to the sale of products or services (collectively, the "Products") by Omron Electronics LLC and its subsidiary companies ("Omron"). Omron objects to any terms or conditions proposed in Buyer's purchase order or other documents which are inconsistent with, or in addition to, these Terms.
2. **Prices; Payment Terms.** All prices stated are current, subject to change without notice by Omron. Omron reserves the right to increase or decrease prices on any unshipped portions of outstanding orders. Payments for Products are due net 30 days unless otherwise stated in the invoice.
3. **Discounts.** Cash discounts, if any, will apply only on the net amount of invoices sent to Buyer after deducting transportation charges, taxes and duties, and will be allowed only if (i) the invoice is paid according to Omron's payment terms and (ii) Buyer has no past due amounts.
4. **Interest.** Omron, at its option, may charge Buyer 1-1/2% interest per month or the maximum legal rate, whichever is less, on any balance not paid within the stated terms.
5. **Orders.** Omron will accept no order less than \$200 net billing.
6. **Governmental Approvals.** Buyer shall be responsible for, and shall bear all costs involved in, obtaining any government approvals required for the importation or sale of the Products.
7. **Taxes.** All taxes, duties and other governmental charges (other than general real property and income taxes), including any interest or penalties thereon, imposed directly or indirectly on Omron or required to be collected directly or indirectly by Omron for the manufacture, production, sale, delivery, importation, consumption or use of the Products sold hereunder (including customs duties and sales, excise, use, turnover and license taxes) shall be charged to and remitted by Buyer to Omron.
8. **Financial.** If the financial position of Buyer at any time becomes unsatisfactory to Omron, Omron reserves the right to stop shipments or require satisfactory security or payment in advance. If Buyer fails to make payment or otherwise comply with these Terms or any related agreement, Omron may (without liability and in addition to other remedies) cancel any unshipped portion of Products sold hereunder and stop any Products in transit until Buyer pays all amounts, including amounts payable hereunder, whether or not then due, which are owing to it by Buyer. Buyer shall in any event remain liable for all unpaid accounts.
9. **Cancellation; Etc.** Orders are not subject to rescheduling or cancellation unless Buyer indemnifies Omron against all related costs or expenses.
10. **Force Majeure.** Omron shall not be liable for any delay or failure in delivery resulting from causes beyond its control, including earthquakes, fires, floods, strikes or other labor disputes, shortage of labor or materials, accidents to machinery, acts of sabotage, riots, delay in or lack of transportation or the requirements of any government authority.
11. **Shipping; Delivery.** Unless otherwise expressly agreed in writing by Omron:
 - a. Shipments shall be by a carrier selected by Omron; Omron will not drop ship except in "break down" situations.
 - b. Such carrier shall act as the agent of Buyer and delivery to such carrier shall constitute delivery to Buyer;
 - c. All sales and shipments of Products shall be FOB shipping point (unless otherwise stated in writing by Omron), at which point title and risk of loss shall pass from Omron to Buyer; provided that Omron shall retain a security interest in the Products until the full purchase price is paid;
 - d. Delivery and shipping dates are estimates only; and
 - e. Omron will package Products as it deems proper for protection against normal handling and extra charges apply to special conditions.
12. **Claims.** Any claim by Buyer against Omron for shortage or damage to the Products occurring before delivery to the carrier must be presented in writing to Omron within 30 days of receipt of shipment and include the original transportation bill signed by the carrier noting that the carrier received the Products from Omron in the condition claimed.
13. **Warranties.** (a) **Exclusive Warranty.** Omron's exclusive warranty is that the Products will be free from defects in materials and workmanship for a period of twelve months from the date of sale by Omron (or such other period expressed in writing by Omron). Omron disclaims all other warranties, express or implied. (b) **Limitations.** OMRON MAKES NO WARRANTY OR REPRESENTATION, EXPRESS OR IMPLIED, ABOUT NON-INFRINGEMENT, MERCHANTABILITY OR FITNESS FOR A PARTICULAR PURPOSE OF THE PRODUCTS. BUYER ACKNOWLEDGES THAT IT ALONE HAS DETERMINED THAT THE PRODUCTS WILL SUITABLY MEET THE REQUIREMENTS OF THEIR INTENDED USE. Omron further disclaims all warranties and responsibility of any type for claims or expenses based on infringement by the Products or otherwise of any intellectual property right. (c) **Buyer Remedy.** Omron's sole obligation hereunder shall be, at Omron's election, to (i) replace (in the form originally shipped with Buyer responsible for labor charges for removal or replacement thereof) the non-complying Product, (ii) repair the non-complying Product, or (iii) repay or credit Buyer an amount equal to the purchase price of the non-complying Product; provided that in no event shall Omron be responsible for warranty, repair, indemnity or any other claims or expenses regarding the Products unless Omron's analysis confirms that the Products were properly handled, stored, installed and maintained and not subject to contamination, abuse, misuse or inappropriate modification. Return of any Products by Buyer must be approved in writing by Omron before shipment. Omron Companies shall not be liable for the suitability or unsuitability or the results from the use of Products in combination with any electrical or electronic components, circuits, system assemblies or any other materials or substances or environments. Any advice, recommendations or information given orally or in writing, are not to be construed as an amendment or addition to the above warranty. See <http://www.omron247.com> or contact your Omron representative for published information.
14. **Limitation on Liability; Etc.** OMRON COMPANIES SHALL NOT BE LIABLE FOR SPECIAL, INDIRECT, INCIDENTAL, OR CONSEQUENTIAL DAMAGES, LOSS OF PROFITS OR PRODUCTION OR COMMERCIAL LOSS IN ANY WAY CONNECTED WITH THE PRODUCTS, WHETHER SUCH CLAIM IS BASED IN CONTRACT, WARRANTY, NEGLIGENCE OR STRICT LIABILITY. Further, in no event shall liability of Omron Companies exceed the individual price of the Product on which liability is asserted.
15. **Indemnities.** Buyer shall indemnify and hold harmless Omron Companies and their employees from and against all liabilities, losses, claims, costs and expenses (including attorney's fees and expenses) related to any claim, investigation, litigation or proceeding (whether or not Omron is a party) which arises or is alleged to arise from Buyer's acts or omissions under these Terms or in any way with respect to the Products. Without limiting the foregoing, Buyer (at its own expense) shall indemnify and hold harmless Omron and defend or settle any action brought against such Companies to the extent based on a claim that any Product made to Buyer specifications infringed intellectual property rights of another party.
16. **Property; Confidentiality.** Any intellectual property in the Products is the exclusive property of Omron Companies and Buyer shall not attempt to duplicate it in any way without the written permission of Omron. Notwithstanding any charges to Buyer for engineering or tooling, all engineering and tooling shall remain the exclusive property of Omron. All information and materials supplied by Omron to Buyer relating to the Products are confidential and proprietary, and Buyer shall limit distribution thereof to its trusted employees and strictly prevent disclosure to any third party.
17. **Export Controls.** Buyer shall comply with all applicable laws, regulations and licenses regarding (i) export of products or information; (ii) sale of products to "forbidden" or other proscribed persons; and (iii) disclosure to non-citizens of regulated technology or information.
18. **Miscellaneous.** (a) **Waiver.** No failure or delay by Omron in exercising any right and no course of dealing between Buyer and Omron shall operate as a waiver of rights by Omron. (b) **Assignment.** Buyer may not assign its rights hereunder without Omron's written consent. (c) **Law.** These Terms are governed by the law of the jurisdiction of the home office of the Omron company from which Buyer is purchasing the Products (without regard to conflict of law principles). (d) **Amendment.** These Terms constitute the entire agreement between Buyer and Omron relating to the Products, and no provision may be changed or waived unless in writing signed by the parties. (e) **Severability.** If any provision hereof is rendered ineffective or invalid, such provision shall not invalidate any other provision. (f) **Setoff.** Buyer shall have no right to set off any amounts against the amount owing in respect of this invoice. (g) **Definitions.** As used herein, "including" means "including without limitation"; and "Omron Companies" (or similar words) mean Omron Corporation and any direct or indirect subsidiary or affiliate thereof.

Certain Precautions on Specifications and Use

1. **Suitability of Use.** Omron Companies shall not be responsible for conformity with any standards, codes or regulations which apply to the combination of the Product in the Buyer's application or use of the Product. At Buyer's request, Omron will provide applicable third party certification documents identifying ratings and limitations of use which apply to the Product. This information by itself is not sufficient for a complete determination of the suitability of the Product in combination with the end product, machine, system, or other application or use. Buyer shall be solely responsible for determining appropriateness of the particular Product with respect to Buyer's application, product or system. Buyer shall take application responsibility in all cases but the following is a non-exhaustive list of applications for which particular attention must be given: (i) Outdoor use, uses involving potential chemical contamination or electrical interference, or conditions or uses not described in this document. (ii) Use in consumer products or any use in significant quantities. (iii) Energy control systems, combustion systems, railroad systems, aviation systems, medical equipment, amusement machines, vehicles, safety equipment, and installations subject to separate industry or government regulations. (iv) Systems, machines and equipment that could present a risk to life or property. Please know and observe all prohibitions of use applicable to this Product.
NEVER USE THE PRODUCT FOR AN APPLICATION INVOLVING SERIOUS RISK TO LIFE OR PROPERTY OR IN LARGE QUANTITIES WITHOUT ENSURING THAT THE SYSTEM AS A WHOLE HAS BEEN DESIGNED TO ADDRESS THE RISKS, AND THAT THE OMRON'S PRODUCT IS PROPERLY RATED AND INSTALLED FOR THE INTENDED USE WITHIN THE OVERALL EQUIPMENT OR SYSTEM.
2. **Programmable Products.** Omron Companies shall not be responsible for the user's programming of a programmable Product, or any consequence thereof.
3. **Performance Data.** Data presented in Omron Company websites, catalogs and other materials is provided as a guide for the user in determining suitability and does not constitute a warranty. It may represent the result of Omron's test conditions, and the user must correlate it to actual application requirements. Actual performance is subject to the Omron's Warranty and Limitations of Liability.
4. **Change in Specifications.** Product specifications and accessories may be changed at any time based on improvements and other reasons. It is our practice to change part numbers when published ratings or features are changed, or when significant construction changes are made. However, some specifications of the Product may be changed without any notice. When in doubt, special part numbers may be assigned to fix or establish key specifications for your application. Please consult with your Omron's representative at any time to confirm actual specifications of purchased Product.
5. **Errors and Omissions.** Information presented by Omron Companies has been checked and is believed to be accurate; however, no responsibility is assumed for clerical, typographical or proofreading errors or omissions.



OMRON ELECTRONICS LLC • THE AMERICAS HEADQUARTERS • Schaumburg, IL USA • 847.843.7900 • 800.556.6766 • www.omron247.com

OMRON CANADA, INC. • HEAD OFFICE

Toronto, ON, Canada • 416.286.6465 • 866.986.6766
www.omron247.com

OMRON ELETRÔNICA DO BRASIL LTDA • HEAD OFFICE

São Paulo, SP, Brasil • 55.11.2101.6300 • www.omron.com.br

OMRON ELECTRONICS MEXICO SA DE CV • HEAD OFFICE

Apodaca, N.L. • 52.811.156.99.10 • 001.800.556.6766 • mela@omron.com

OMRON ARGENTINA • SALES OFFICE

Cono Sur • 54.11.4783.5300

OMRON CHILE • SALES OFFICE

Santiago • 56.9.9917.3920

OTHER OMRON LATIN AMERICA SALES

54.11.4783.5300

OMRON EUROPE B.V. Wegalaan 67-69, NL-2132 JD, Hoofddorp, The Netherlands. Tel: +31 (0) 23 568 13 00 Fax: +31 (0) 23 568 13 88 www.industrial.omron.eu