

*PA4600 Perimeter Access Guarding Device/
PA4600BB Bounced Back Perimeter Access Guarding Device
Installation and Operating Manual
Original Instructions*

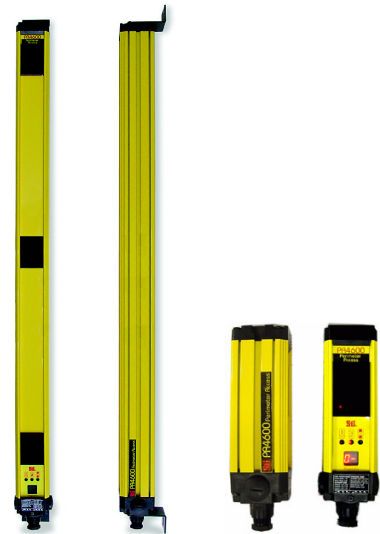

OMRON Scientific Technologies Inc.

6550 Dumbarton Circle

Fremont, CA 94555 USA

USA: 800.556.6766

Canada: 866.986.6766

Mexico and South America: 847.843.7900

All other countries: 510.608-3400

www.sti.com/info



PA4600/PA4600BB Perimeter Access Guarding Device

Table of Contents

Section 1-- Important Safety Warnings	page 5
Section 2-- Significant Features.	page 6
2.1 Standard Features	page 6
2.2 Optional Features	page 6
Section 3-- System Components and Indicators.	page 7
Section 4-- System Operation.	page 8
4.1 Operating States.	page 8
4.1.1 Machine Run.	page 8
4.1.2 Machine Stop	page 8
4.1.3 Interlock	page 8
4.1.4 Alarm	page 8
4.2 Operating Modes	page 8
4.2.1 Automatic Start	page 8
4.2.2 Start Interlock	page 9
4.2.3 Start/Restart Interlock	page 9
4.3 Operating Mode Selection	page 10
Section 5-- Diagnostic and Test Features	page 12
5.1 Individual Beam Indicators	page 12
5.2 Synchronization Beam (PA4600 only)	page 12
5.3 Machine Primary Control Element (MPCE) Monitoring	page 12
5.3.1 Activating and deactivating MPCE Monitoring.	page 12
5.4 Machine Test Signal (MTS) - Optional for PA4600 Only	page 12
5.5 Start/Restart Selection Options	page 13
Section 6-- Outputs	page 14
6.1 Safety Outputs	page 14
6.2 Auxiliary Output	page 14
6.2.1 NPN, Auxiliary Output	page 14
6.2.2 PNP, Auxiliary Output	page 15

<i>Section 7-- Safe Mounting Distance</i>	page 15
7.1 <i>US Safe Distance Formulas</i>	page 16
7.2 <i>European Safety Distance Formulas</i>	page 17
<i>Section 8-- Installation</i>	page 18
8.1 <i>Reflective Surface Interference</i>	page 18
8.1.1 <i>Additional Guarding</i>	page 20
8.1.2 <i>Installation of Multiple Systems</i>	page 21
8.1.3 <i>Access to Configuration Switches</i>	page 21
8.1.4 <i>Alignment</i>	page 21
8.1.5 <i>Cable Assemblies</i>	page 21
8.1.6 <i>Input Power Requirements/Connections</i>	page 21
8.1.7 <i>Special Requirements for Perimeter Guarding</i>	page 21
8.1.8 <i>Presence Sensing Device Initiation</i>	page 21
<i>Section 9-- Connecting to The Machine Control Circuit</i>	page 22
9.1 <i>Connecting to a Safety Monitoring Device</i>	page 23
9.2 <i>Connecting Via an RM-1 Module</i>	page 24
9.3 <i>Connecting Via Two Force-Guided Relays</i>	page 25
9.4 <i>Connecting to machine Control System Via RM-2AC</i>	page 26
9.5 <i>Connecting to Machine Control System Via RM3</i>	page 27
<i>Section 10-- Checkout and Test Procedures</i>	page 28
<i>Section 11-- Cleaning</i>	page 28
<i>Section 12-- Specifications and Additional Information</i>	page 29
12.1 <i>System Specifications</i>	page 29
12.3 <i>Dimensional Drawing</i>	page 31
12.4 <i>Spare Parts</i>	page 33
12.4.1 <i>Transmitters Model Numbers</i>	page 33
12.4.2 <i>Receivers Model Numbers</i>	page 33
12.4.3 <i>PA4600BB transceiver</i>	page 34
12.4.4 <i>PA4600BB Passive</i>	page 34
12.4.5 <i>Cables</i>	page 35
12.4.6 <i>Others</i>	page 35

12.5 Warranty	page 36
12.6 Patents	page 36
12.7 Trademarks	page 36
12.8 Repairs	page 36
12.9 Documentation Criteria	page 36
Section 13-- Glossary	page 37
Section 14-- Troubleshooting	page 38
14.1 Receiver Indicator Lights	page 38
14.2 Transmitter Indicator Light	page 38
Appendix A —Checkout Procedure	page 39
A.1 Checkout Procedure Log	page 39
Appendix B —Test Procedure	page 40
B.1 Test Procedure Log	page 40
Appendix C —Declaration of Conformity Information	page 41

Table of Figures

Figure 3-1 PA4600 Mechanical Drawing	page 7
Figure 4-1 Functional Flow Diagram	page 9
Figure 4-2 Access to Configuration Switches for PA4600 system	page 10
Figure 4-3 Access to Configuration Switches for PA4600BB	page 10
Figure 5-1 NO1 - Normally Open Option and connect to to 0 VDC	page 13
Figure 5-2 NO2 - Normally Open and connect to +24VDC (Special Order on PA4600BB)	page 13
Figure 5-3 NC1 - Normally Closed and connect to 0 VDC (Special Order on PA4600BB)	page 13
Figure 5-4 NC2 - Normally Closed and connect to +24 VDC (Special Order on PA4600BB)	page 13
Figure 7-1 Safe Mounting Distance	page 15
Figure 7-2 Dpf Calculation	page 16
Figure 8-1 Correct Mounting Example with Proper Alignment (Top View)	page 18
Figure 8-2 Unsafe Mounting Example (Top View)	page 18
Figure 8-3 Unsafe Mounting Example (Front View)	page 18
Figure 8-4 Worst Case Alignment Example	page 19
Figure 8-5 Maximum Range of PA4600BB Reflective Surface Interface	page 19

Figure 8-6 <i>Min. Distance from a Reflective Surface as a Function of Range General Considerations...</i>	page 19
Figure 8-7 <i>Correct PA4600/PA4600BB Installation Example</i>	page 20
Figure 8-8 <i>Multiple Perimeter Guards Installation Configurations</i>	page 20
Figure 8-9 <i>Multiple Perimeter Guards Installation Configurations using Scan Coding</i>	page 20
Figure 8-10 <i>Pin Out Diagram for Transmitter Cable</i>	page 21
Figure 8-11 <i>Pin Out Diagram for PA4600 Receiver Cable and PA4600BB Transceiver</i>	page 21
Figure 9-1 <i>Connector Options</i>	page 22
Figure 9-3 <i>Connecting via an RM-1 Module</i>	page 24
Figure 9-4 <i>Connecting Via Two Force-guided Relays</i>	page 25
Figure 9-5 <i>Connecting Via RM-2AC</i>	page 26
Figure 9-6 <i>Connecting Via RM3 Module</i>	page 27
Figure 12-1 <i>PA4600/PA4600BB Dimensional Drawing</i>	page 31
Figure 12-2 <i>Receiver and Transmitter Front View and Mounting Brackets</i>	page 31
Figure 12-3 <i>Mounting Brackets</i>	page 32

Table of Tables

Table 4-1 <i>Receiver Mode Options (Larger Switch)</i>	page 11
Table 4-2 <i>Receiver Code Options (Smaller Switch)</i>	page 11
Table 4-3 <i>Transmitter Configuration Options</i>	page 11
Table 5-1 <i>MPCE Switch Settings (Receiver)</i>	page 12
Table 5-2 <i>Diagnostic Code Listing</i>	page 14
Table 7-1 <i>Most Practical Positions for Multiple Beams Systems</i>	page 14
12.1 <i>System Specifications</i>	page 29
12.2 <i>Inputs and Outputs Cable Length Limitations</i>	page 30
Table 14-1 <i>Diagnostic Code Listing</i>	page 38



1

1 IMPORTANT SAFETY WARNINGS

⚠ WARNING! Read and understand this section prior to installing the PA4600/PA4600BB system.

A PA4600/PA4600BB system is a multiple beam presence sensing device designed to guard personnel working around moving machinery.

Whether a specific machine application and PA4600/PA4600BB system installation complies with safety regulations depends on the proper application, installation, maintenance and operation of the PA4600/PA4600BB system. These items are the responsibility of the purchaser, installer and employer.

The employer is responsible for the selection and training of personnel to properly install, operate, and maintain the machine and its safeguarding systems. A PA4600/PA4600BB system should only be installed, verified and maintained by a **qualified** person. A qualified person is defined as “*an individual who understands, is trained on, and demonstrates competence with the construction, operation or maintenance of the machinery and the hazards involved.*” (ANSI/PMMA B155.1-2006)

To use a PA4600/PA4600BB system the following requirements must be met:

- The guarded machine **must** be able to stop anywhere in its cycle.
- A Multiple Beam Safety Device is designed for detection of personnel and equipment entering a hazardous area and not for the detection of hands and fingers only.
- Do not use a safety light curtain Multiple Beam Safety Device around a press with a full-revolution clutch.
- The guarded machine must not present a hazard from flying parts.
- The guarded machine must have a consistent stopping time and adequate control mechanisms.
- Severe smoke, particulate matter and corrosives may degrade the efficiency of a safety light curtain. Do not use the PA4600/PA4600BB system in this type of environment.
- All applicable governmental and local rules, codes, and regulations must be satisfied. This is the employer’s responsibility.
- All safety-related machine control elements must be designed so that a fault in the control logic or failure of the control circuit does not lead to a failure to danger.
- Additional guarding may be required for access to dangerous areas not covered by the PA4600/PA4600BB system.
- Perform the STI test procedure at installation and after maintenance, adjustment, repair or modification to the machine controls, tooling, dies or machine, or the PA4600/PA4600BB system.
- Perform only the test and repair procedures outlined in this manual.
- Follow all procedures in this manual for proper operation of the PA4600/PA4600BB system.

The enforcement of these requirements is beyond the control of OMRON STI. The employer has the sole responsibility to follow the preceding requirements and any other procedures, conditions and requirements specific to his machinery.

⚠ WARNING! Despite inherent safe design measures, safeguarding and complementary protective measures adopted by the user, residual risk may remain in any installation. Potential risks are strictly under the control of the end user and may include severe injury or death.

2 SIGNIFICANT FEATURES

2.1 STANDARD FEATURES

Individual Beam Indicators

External Device Monitoring (MPCE Monitoring)

Automatic Start Mode

Start interlock Mode

Start/Restart interlock Mode

Adjustable Mounting Brackets

Diagnostics display

Three scan codes

Two Safety (PNP) Outputs

Auxiliary Output (NPN)

All intelligence is in the transmitter and receiver. No separate control box required.

2.2 OPTIONAL FEATURES

Machine Test Signal (MTS)

PNP Auxiliary Output Configuration Optional

M12 Quick Disconnect Connectors

Start Input Configuration

3 SYSTEM COMPONENTS AND INDICATORS

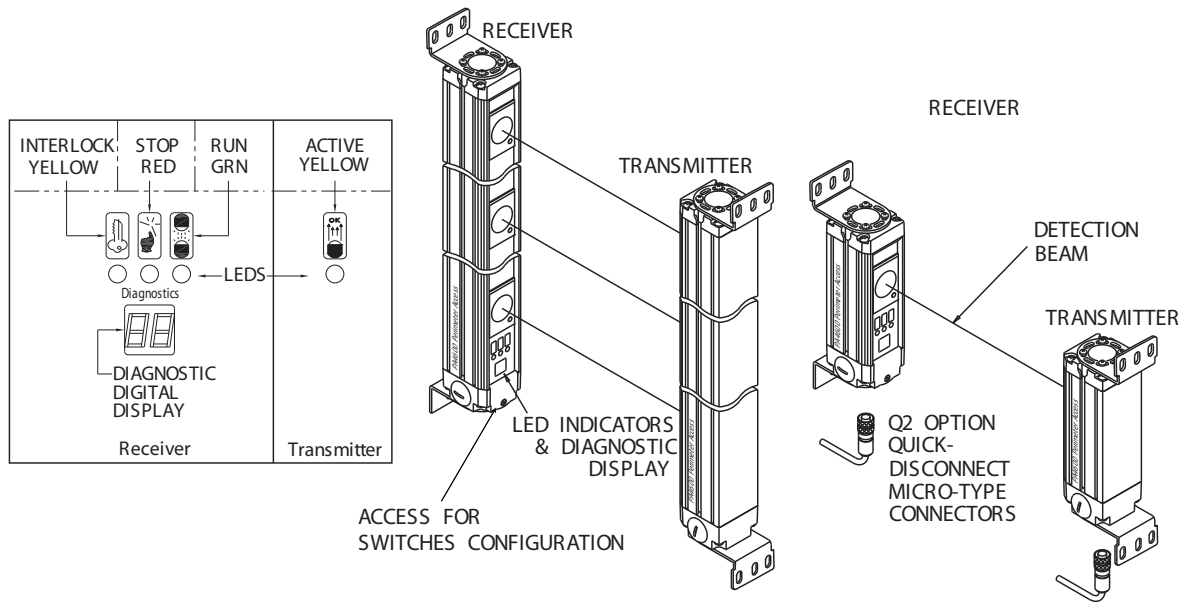

Figure 3-1 PA4600 Mechanical Drawing

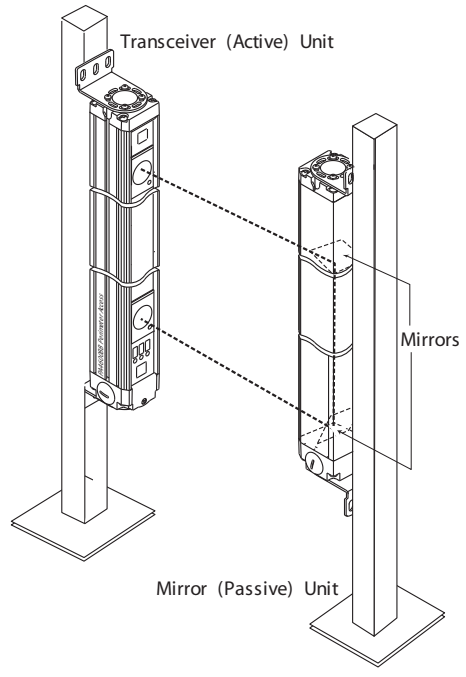

Figure 3-2 PA4600BB Mechanical Drawing

4 SYSTEM OPERATION

A PA4600/PA4600BB system is a microprocessor-controlled, infrared transmitted-beam safety device. The system consists of a receiver assembly and a transmitter assembly. The receiver and transmitter assemblies are not physically interconnected. The PA4600BB integrates the receiver and transmitter into one assembly which is mated with a passive unit and do not require electrical connection.

The PA4600/PA4600BB system is used where personnel protection is required. Typical applications include whole body detection around hazardous equipment such as robotic work cells, transfer lines, assembly lines, turret punch presses, palletizers, filter presses, welding stations, roll handling equipment, coilers and uncoilers and automated equipment.

4.1 OPERATING STATES

The operating condition of a PA4600/PA4600BB system is described in terms of states. The following operating states exist for the PA4600/PA4600BB system.

4.1.1 MACHINE RUN

The two receiver safety outputs are in the ON state, the green machine run indicator is lit, diagnostic displays '--', and the auxiliary output is in a state consistent with its configuration. See Section 4.3--*Operating Mode Selection*. The protected machine is allowed to operate.

4.1.2 MACHINE STOP

The two receiver safety outputs are in the OFF state, the red machine stop indicator is lit, diagnostic displays '-0', and the auxiliary output is in an OFF state. The protected machine is not allowed to operate.

4.1.3 INTERLOCK

The two receiver safety outputs are in the OFF state, the red machine stop indicator and yellow interlock indicator are lit, diagnostic displays '-1' and the auxiliary output is in OFF state. The interlock state does not allow the protected machine to operate until the detection zone is clear of obstructions and the start button is pressed and released.

4.1.4 ALARM

The two receiver safety outputs are in the OFF state, the red machine stop indicator is lit, the yellow interlock indicator is flashing. The auxiliary output is in a state consistent with its configuration. See *Operating Mode Selection* on page 10. The diagnostic displays a diagnostic code to aid in troubleshooting. The alarm state does not allow the protected machine to operate. The primary difference between alarm and interlock is that the PA4600/PA4600BB system will remain in the alarm state until the fault is corrected, regardless of power cycling or the start button is pressed and released.

4.2 OPERATING MODES

System operating modes determine the start-up and operating behavior of a PA4600/PA4600BB system. Operating mode definitions rely on the operating states presented above. Operating mode selection is performed via configuration switches in the receiver endcap.

NOTE! If internal faults are detected by the PA4600/PA4600BB system during power-up or operation, it will enter an alarm status with its safety outputs in the OFF state.

4.2.1 AUTOMATIC START

A PA4600/PA4600BB system will power-up with its safety and auxiliary outputs OFF, and, if the detection zone is not obstructed, enter the Machine Run state. In this state, when an object is sensed entering the detection zone, the PA4600/PA4600BB system will change from Machine Run to

Machine Stop and remain in this state until the obstruction is removed. Once the detection zone is clear, the PA4600/PA4600BB system will automatically change from Machine Stop to Machine Run.

4.2.2 START INTERLOCK

The PA4600/PA4600BB system will power-up with its safety outputs OFF, and, if no faults are detected, enter the interlock state. To enter the Machine Run state, the detection zone must be clear, and then the operator must press and release the Start button. Once in the Machine Run state, when an object is sensed entering the detection zone the PA4600/PA4600BB system will change from Machine Run to Machine Stop. Once the detection zone is clear, the PA4600/PA4600BB system will automatically change from Machine Stop to Machine Run.

4.2.3 START/RESTART INTERLOCK

A PA4600/PA4600BB system will power-up with its safety outputs OFF, and, if no faults are detected, enter the interlock state. To enter the machine run state, the detection zone must be clear, and then the operator must press and release the Start button. Once in the Machine Run state, when an object is sensed entering the detection zone the PA4600/PA4600BB system will change from Machine Run to Machine Stop. The PA4600/PA4600BB system will change to an interlock state after the obstruction is removed from the detection zone. To enter the Machine Run state, the operator must press and release the start button. If any obstruction is present in the detection zone when the start button is pressed and released, the PA4600/PA4600BB system will remain in the Machine Stop state.

NOTE: The definitions above mention a start button. Section 9-- Connecting to The Machine Control Circuit.

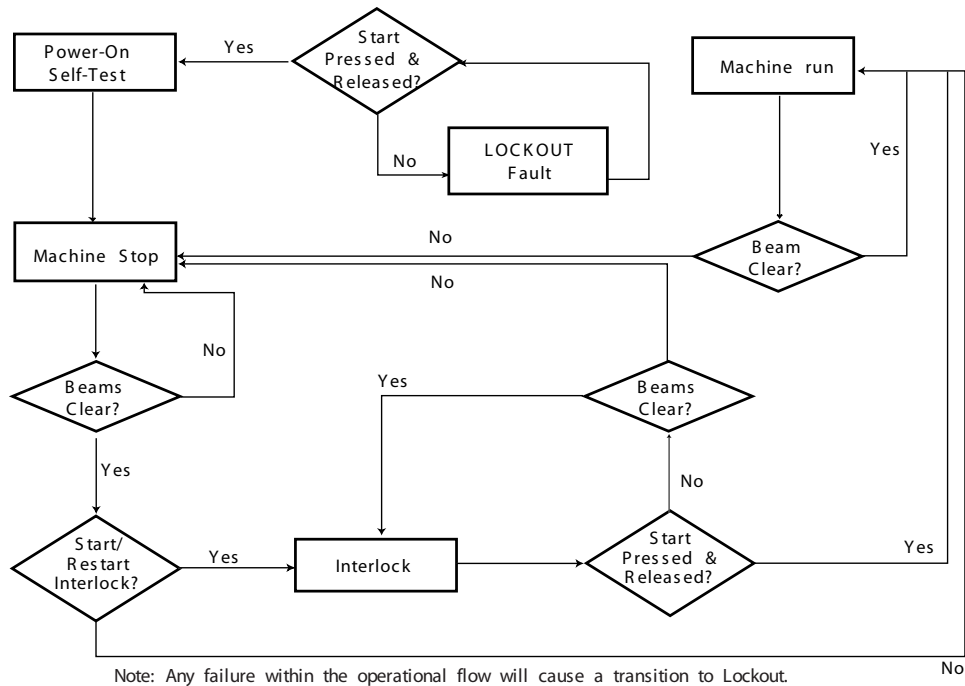

Figure 4-1 Functional Flow Diagram

4.3 OPERATING MODE SELECTION

The Operating mode is selected by configuration of the switches located inside the receiver and transmitter. To access the switches, remove the front retaining screw on the end caps.

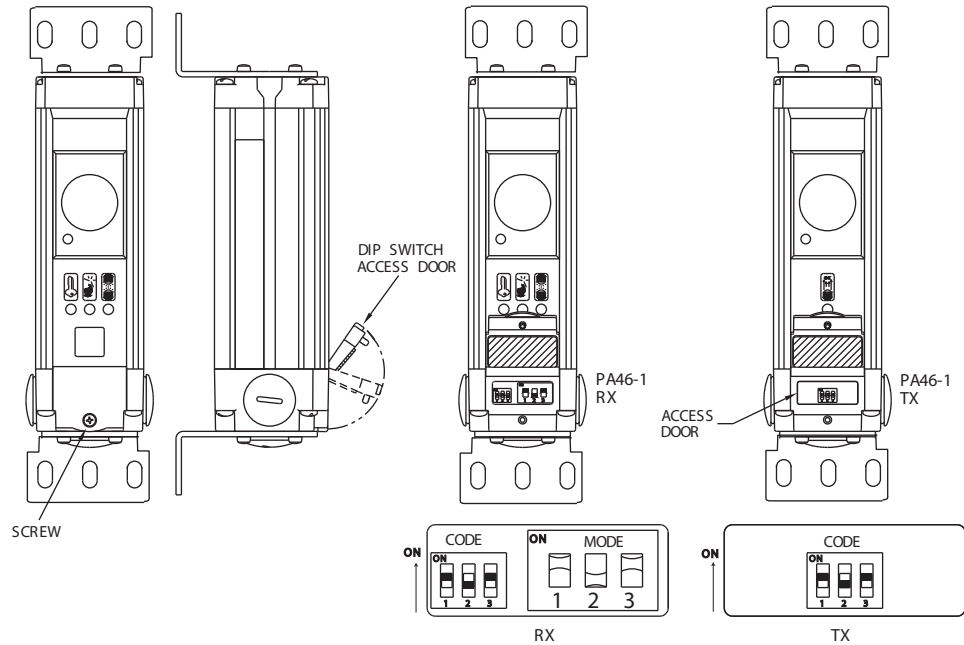

Figure 4-2 Access to Configuration Switches for PA4600 system

Warning! Disconnect power before opening end caps.

Refer to Table 4-1 and Table 4-2 for receiver configuration options. Refer to Table 4-3 for transmitter configuration options. For PA4600BB configurations refer to all tables.

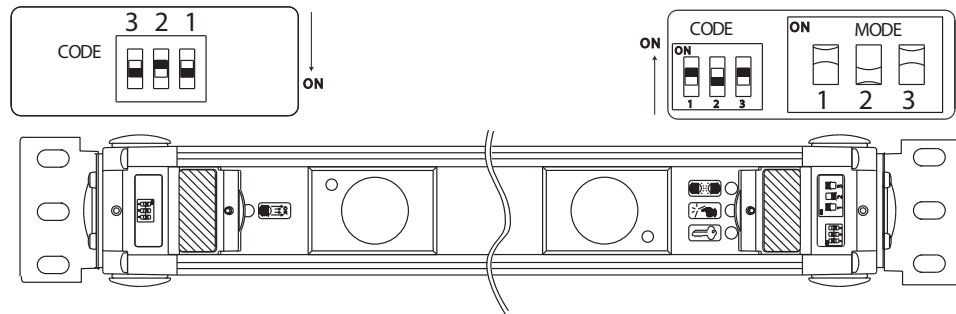

Figure 4-3 Access to Configuration Switches for PA4600BB



Table 4-1 Receiver Mode Options (Larger Switch)

Switch	Function Selection	Description
1 & 2	Start Mode	Automatic Start: 1 = On, 2 = On Start Interlock: 1 = Off, 2 = On Invalid Setting: 1 = On, 2 = Off Start/Restart Interlock: 1 = Off, 2 = Off
3	MPCE Monitoring	Enable = Off, Disabled = On

Table 4-2 Receiver Code Options (Smaller Switch)

Switch	Function Selection	Description
1	Auxiliary Output Mode	Follow OSDD Output = On Alarm Mode = Off
2 & 3	Scan Code	A: 2 = Off, 3 = Off B: 2 = On, 3 = Off C: 2 = Off, 3 = On Invalid: 2 = On, 3 = On

Table 4-3 Transmitter Configuration Options

Switch	Function Selection	Description
1	Range Selection	0.8 to 20 meter: 1 = Off > 20 meter: 1 = On
2 & 3	Scan code	A: 2 = Off, 3 = Off B: 2 = On, 3 = Off C: 2 = Off, 3 = On Invalid: 2 = On, 3 = On

5 DIAGNOSTIC AND TEST FEATURES

5.1 INDIVIDUAL BEAM INDICATORS

The PA4600/PA4600BB system has a visible, red Individual Beam Indicator (IBI), adjacent to each receiver infrared beam. The IBI will light when the infrared beam fails to meet the conditions necessary for the PA4600/PA4600BB system to remain in the machine run state. When the synchronization beam is broken, all IBI will light. IBI are not a safety critical component. An IBI failure will not cause an alarm condition and the PA4600/PA4600BB system will continue to operate. The PA4600BB has one visible beam indicator adjacent to the receiver beam.

5.2 SYNCHRONIZATION BEAM (PA4600 ONLY)

Synchronization between the PA4600 transmitter and receiver elements is optical. The beam closest to the cable connector supplies this signal. When this beam is blocked, the system will enter a machine stop state and all Individual Beam Indicators will light. When the beam is cleared, the system will resynchronize itself and enter a state consistent with its operating mode.

5.3 MACHINE PRIMARY CONTROL ELEMENT (MPCE) MONITORING

MPCE monitoring is an important safety function. It monitors the PA4600/PA4600BB system interface to the guarded machine and checks to ensure that the control elements (switching devices such as contactors) are responding correctly to the PA4600/PA4600BB and to detect any inconsistency between the two machine primary control elements.

Connections for MPCE monitoring are made at the receiver. On power-up, the PA4600/PA4600BB system looks for an MPCE closed condition (Off state where the monitoring contacts are closed). If this is found, it will enter a state consistent with the selected operating mode. When the PA4600/PA4600BB system enables its safety outputs, it monitors the MPCE contacts for a closed-to-open transition. This transition must occur within 300 ms or the PA4600/PA4600BB system considers the MPCE faulted. The PA4600/PA4600BB system will then enter an alarm state. Additionally, if the MPCE connectors are incorrectly wired, the PA4600/PA4600BB system will enter an alarm state.

NOTE! For proper operation of the PA4600/PA4600BB system when MPCE is not active, the MPCE input must be wired to the PA4600/PA4600BB system ground.

5.3.1 ACTIVATING AND DEACTIVATING MPCE MONITORING

MPCE monitoring is activated by setting position 3 on the “Mode switch” located inside the receiver endcap or the PA4600BB transceiver endcap. Refer to *Table 5-1*. To access the switches, open the access door.

Switch	Function Selection	Description
3	MPCE Monitoring	Enabled = Off, Disabled = On

Table 5-1 MPCE Switch Settings (Receiver)

5.4 MACHINE TEST SIGNAL (MTS) - OPTIONAL FOR PA4600 ONLY

Some applications require that the machine guarding system be tested by the machine controller during a non-hazardous portion of the machine cycle to verify that the guarding system is functioning properly. The MTS option on the transmitter provides this capability.

MTS is provided by placing a normally-closed switch across the MTS and MTS Return lines of the transmitter. When the transmitter recognizes a close-to-open transition on this switch a beam block state will be simulated on the transmitter and the receiver will enter the machine stop state. MTS is

active as long as the switch is held open. The external MTS contact must be closed during power-up. If MTS is not used, a jumper must be installed across MTS and MTS Return.

PA4600BB does not come with this feature.

5.5 START/RESTART SELECTION OPTIONS

The PA4600/PA4600BB offers four Start/Restart input type selections. The start function type needs to be selected at time of order, as it is only factory configurable. The description for each specific start input are shown below. Refer to the serial number label of your PA4600/PA4600BB to determine the configuration type of your unit. All four of the configurations will re-set on the trailing edge, on press and release of the restart switch.

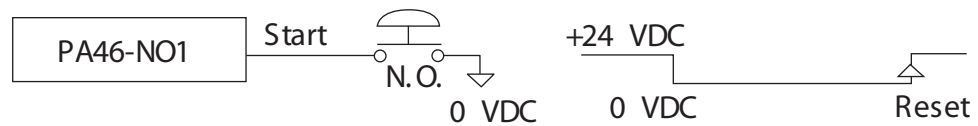

Figure 5-1 NO1 - Normally Open Option and connect to 0 VDC



Figure 5-2 NO2 - Normally Open and connect to +24VDC (Special Order on PA4600BB)

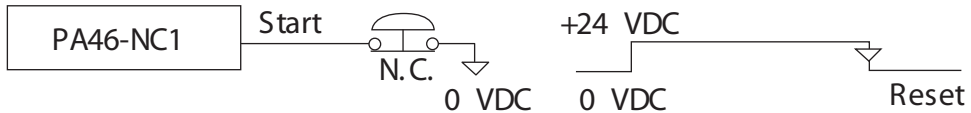

Figure 5-3 NC1 - Normally Closed and connect to 0 VDC (Special Order on PA4600BB)

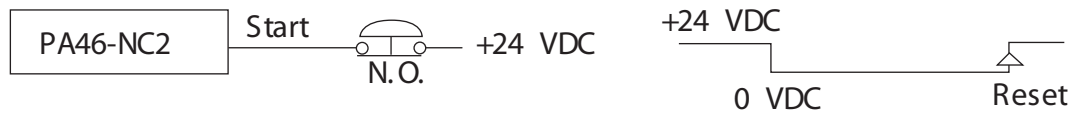

Figure 5-4 NC2 - Normally Closed and connect to +24 VDC (Special Order on PA4600BB)

5.6 DIAGNOSTIC DISPLAY

The PA4600 receiver and the PA4600BB transceiver have a two-digit numeric display that displays diagnostic codes identified by the internal control circuits. This display is visible from the front of the receiver. See *Figure 3-1 PA4600 Mechanical Drawing* on page 7.

These Diagnostic Codes indicate normal operation, dipswitch setting faults, OSSD faults, MPCE faults and internal controller faults. The diagnostic codes used in the PA4600/PA4600BB are given in the following table.

Table 5-2 Diagnostic Code Listing

Code Group	Code Number	Meaning of Diagnostic Code
Normal Operation	88/V#	During Power-Up all of the segments are lit and then the software version number is displayed.
	--	RUN state
	- 0	STOP state
	- 1	In the Interlock state and waiting for Start Input
Configuration Switch Faults	21	Invalid Mode selection setting.
	22	Switch settings changed during operation.
	26	Invalid Code setting
Safety Output (OSSD) Faults	31	Safety Output A & B are shorted together.
	32	Safety Output A shorted to Power.
	33	Safety Output B shorted to Power.
	34	Safety Output A shorted to Ground.
	35	Safety Output B shorted to Ground.
MPCE Faults	41	MPCE signal was in Wrong state BEFORE entering the Machine RUN state.
	42	MPCE signal was in Wrong state AFTER entering the Machine RUN state.
	43	MPCE signal was in Wrong state during power-up of the PA4600/PA4600BB.
Receiver Fault	50	A fault internal to the PA4600/PA4600BB has been detected.
Setup Error	60	Receiver in view of Multiple Transmitters set to same scan code.

6 OUTPUTS

6

6.1 SAFETY OUTPUTS

⚠ WARNING! *This product is designed for use on a 24 VDC, negative ground (functional ground) electrical system only. Never connect the PA4600/PA4600BB system to a positive ground system. With a positive ground wiring scheme, certain simultaneous shorts of both safety outputs may not be detected and the guarded machine may not stop resulting in severe operator injury.*

The PA4600 system receiver and the PA4600BB transceiver supply two independent PNP-type, safety outputs to provide run/stop signals to the guarded machine. In the machine run state, the safety outputs are electrically conducting and source 625 milliamps each (max.) of current at 24 VDC. In the machine stop state, the outputs are not electrically conducting.

6.2 AUXILIARY OUTPUT

This is not a safety output. The PA4600/PA4600BB system supplies one auxiliary output. The configuration of this output is can be set by adjusting the switch. See Table 4-2 *Receiver Code Options (Smaller Switch)* for switch configurations.

6.2.1 NPN, AUXILIARY OUTPUT

In the ON state this NPN output will sink up to 100 mA.(A standard feature for PA4600BB, and selectable at the time of ordering for PA4600)



6.2.2 PNP, AUXILIARY OUTPUT

In the ON state this PNP output will source up to 100 mA at 24 VDC. The auxiliary output is field configurable to operate in Follow mode or Alarm mode. (Available at the time of order for PA4600).

7 SAFE MOUNTING DISTANCE

7

WARNING! Never install a PA4600/PA4600BB system without regard to the safety distance. If the PA4600/PA4600BB system is mounted too close to the point of operation hazard, the machine may not stop in time to prevent an operator injury.

A PA4600/PA4600BB system must be mounted far enough from the machine danger zone so the machine will stop before a hand or other body part reaches the hazardous area. This distance is called the safety distance. It is a calculated number based on a formula. See *Figure 7-1 Safe Mounting Distance* on page 15 for an illustration of the safety distance. Regardless of the calculated distance, a PA4600/PA4600BB system should never be mounted closer to point of operation hazard than specified.

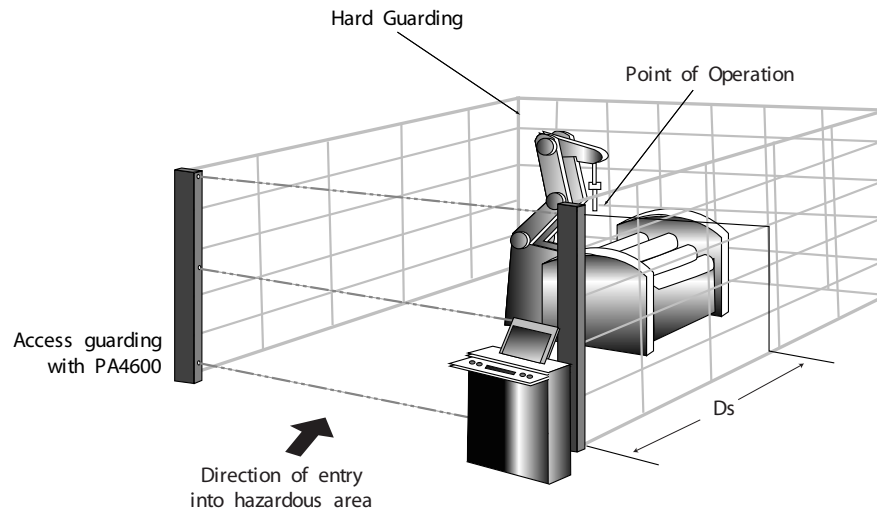

Figure 7-1 Safe Mounting Distance

7.1 US SAFE DISTANCE FORMULAS

In the United States several formulas exist to properly determine the safety distance for a safety light curtain. In the case of a perimeter access guard, such as the PA4600/PA4600BB, STI recommends the formula provided by the Robotic Industries Association (RIA) through the American National Standards Institute (ANSI)

$$D_s = K \times (T_s + T_c + T_r + T_{bm}) + D_{pf}$$

Where:

D_s = minimum safety distance between the PA4600/PA4600BB detection zone and the nearest point of operation hazard.

K = speed constant: 1.8 m/sec. (63 inches/sec.) minimum which assumes the operator starts a hand motion toward the point of operation from rest.

According to ANSI B11.19-1990, "The value of the hand speed constant, K, has been determined by various studies and although these studies indicate speeds of 63 in./sec. to over 100 in./sec., they are not considered conclusive determinations. The user should consider all factors, including the physical ability of the operator, when determining the value of K to be used."

T_s = worst stop time of the machine or equipment. Measured at maximum velocity.

T_c = worst stop time of the control system

T_r = response time of the safeguarding device, including its interface.

NOTE! $T_s + T_c$ is usually measured together by a stop time measuring device.

T_r = the response time of the PA4600/PA4600BB system, in seconds. This response time is given in Section 12.1-- System Specifications.

WARNING! When using an STI RM-1 or RM-X with the PA4600/PA4600BB system, add 8 misc. to the response times stated in Section 12.1-- System Specifications.

D_{pf} = maximum travel towards the hazard within the PA4600/PA4600BB detection zones that may occur before a stop is signaled. Depth penetration factors will change depending on the model and the application. D_{pf} is 0.9m (36 inches) for an application that only allows a person's arm to reach through the detection zone, typically a model with three or more beams. D_{pf} is 1.2m (48 inches) for an application that allows a person to bend over the detection zone and reach through it towards the hazard typically a two beam model. See Figure 7-2.

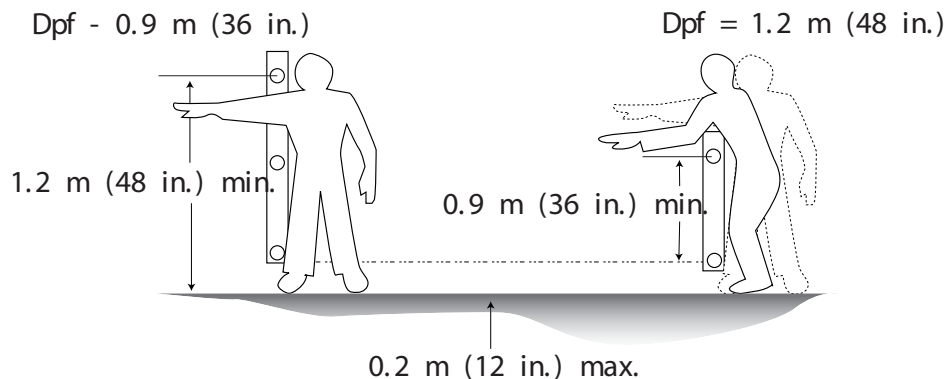

Figure 7-2 Dpf Calculation

NOTE! If the guarded machine is not equipped with a stop time performance monitor, a percentage increase factor should be applied to the stop time of the machine to allow for braking system wear. Contact your machine manufacturer for information.



7.2 EUROPEAN SAFETY DISTANCE FORMULAS

The following discussion is based on standard EN999 and applies to Multiple Separate Beam systems. It describes the safety distance formula for systems with a minimum object resolution greater than 70mm.

When the minimum object resolution of the system is greater than 70 mm, use the following formula:

$$S = (K \times T) + C$$

where:

S = the minimum distance in millimeters, from the danger zone to the detection point, line, plane or zone.

K = 1600 mm/s

T = the overall system stopping performance in seconds.

$$T = t1 + t2$$

t1 = response time of the safety light curtain in seconds. This response time is given in Section 12.1--*System Specifications*.

t2 = maximum stopping time of the machine in seconds.

C = 850 mm.

i.e.:

$$S = (1600 \text{ mm/s} \times T) + 850 \text{ mm.}$$

Perimeter Access systems consist of multiple separate beams. These types of devices are designed for body detection, not torso detection. During the risk assessment the following possible scenarios should be taken into account:

- Crawling below the lowest beam
- Reaching over the top beam
- Reaching through two of the beams
- Bodily access, intrusion between two beams.

The table below shows the most practical positions for a 2, 3 and 4 beam system.

Table 7-1 Most Practical Positions for Multiple Beams Systems

Number of Beams	Heights above Reference plane, e.g. floor
4	300, 600, 900, 1,200 mm
3	200, 700, 1,100 mm
2	400, 900 mm

- Single Beam Units:

If the risk assessment determines that a single beam system is appropriate the following formula should be used for calculating minimum mounting distance:

$$S = (1600 \text{ mm/s} \times T) + 1200 \text{ mm}$$

A height of 750mm from the reference plane, e.g. floor is recommended per EN294:1992 sec.4.1.1.

8 INSTALLATION

8

8.1 REFLECTIVE SURFACE INTERFERENCE

A reflective surface adjacent to the detection zone can deflect the optical beam and may cause an obstruction in the zone not to be detected. (See *Figure 8-2* and *Figure 8-3*.) The reflective surface may be part of the machine, mechanical guard or workpiece. Therefore, a minimum distance (d) must exist between the reflective object and the center line of the PA4600/PA4600BB system detection zone. The Test Procedure (Appendix B) must be used to test for this condition.

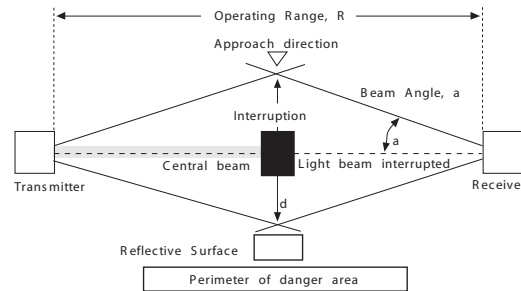

Figure 8-1 Correct Mounting Example with Proper Alignment (Top View)

The interruption is clearly detected. The reflective object is outside of the beam angle.

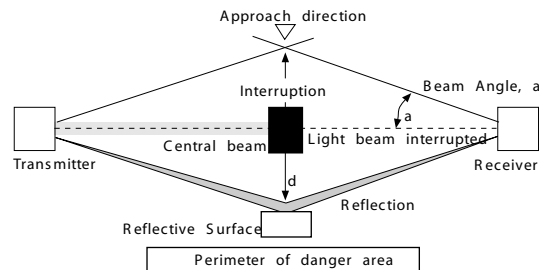

Figure 8-2 Unsafe Mounting Example (Top View)

The interruption may not be detected because of the reflection. The reflective object is inside the beam angle.

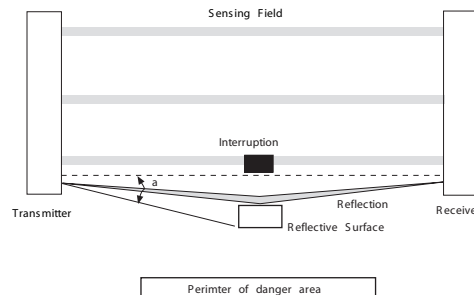

Figure 8-3 Unsafe Mounting Example (Front View)

Interruption may not be detected because of the reflection. Reflective surface interference may also appear above and below the sensing field.

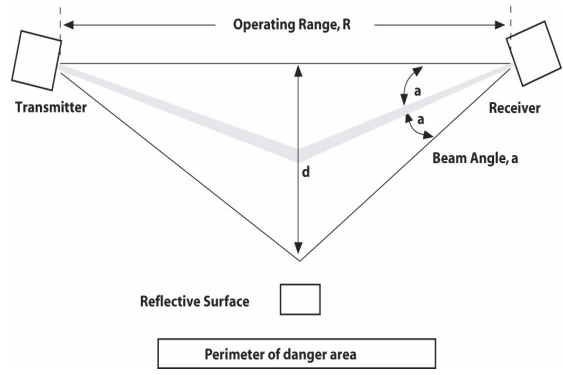

Figure 8-4 Worst Case Alignment Example

This example shows the minimum distance from the reflective surface, d , to one side of the beam center line. This is applicable for installations without the use of mirrors for multiple side guarding.

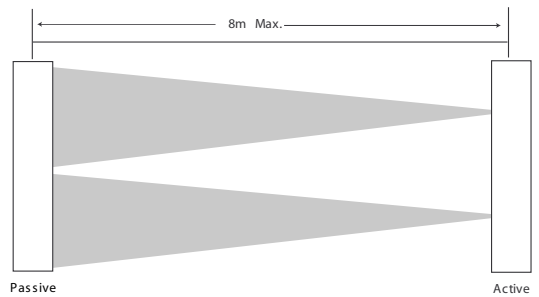

Figure 8-5 Maximum Range of PA4600BB Reflective Surface Interface

This example shows the maximum range of a PA4600BB. To avoid beams from overlapping the PA4600BB must not be mounted at a distance greater than 8 meters.

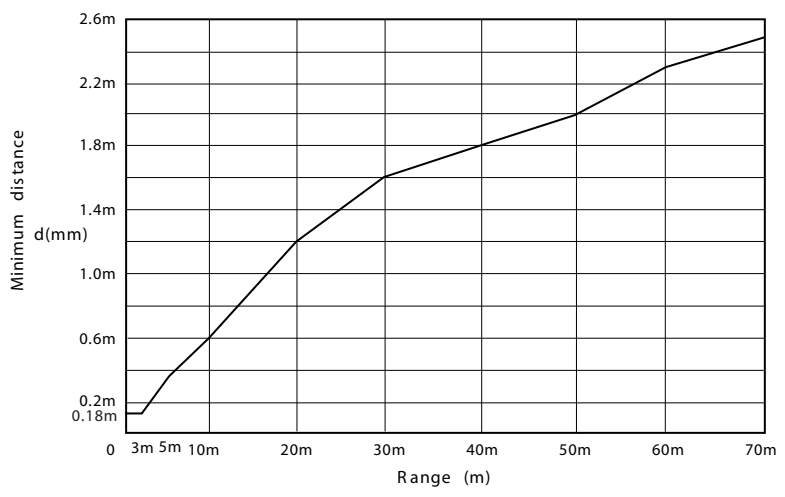

Figure 8-6 Min. Distance from a Reflective Surface as a Function of Range General Considerations

8.1.1 ADDITIONAL GUARDING

Areas of access to the point of hazardous operation not guarded by the PA4600/PA4600BB system must be protected by suitable means such as a fixed barrier guard, an interlocked guard or a safety mat.

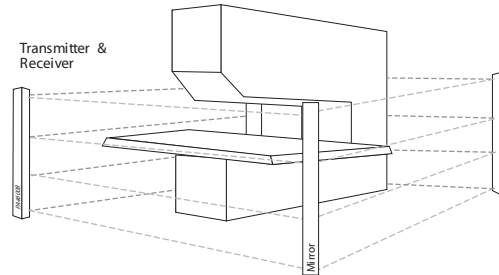

Figure 8-7 Correct PA4600/PA4600BB Installation Example

8.1.2 INSTALLATION OF MULTIPLE SYSTEMS

When two or more PA4600/PA4600BB systems with the same scan code are mounted in close proximity and in alignment with each other, precautions should be taken to avoid one system interfering with another. This can be corrected by mounting the transmitters and receivers back-to-back or stacked. See Figure 8-8 for reference.

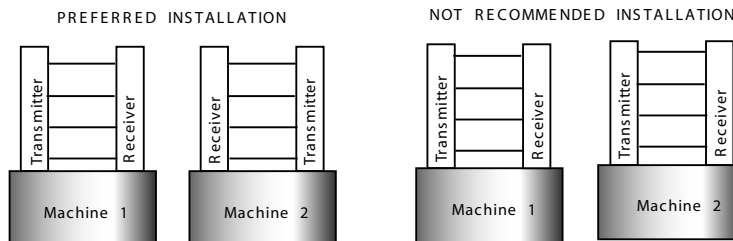

Figure 8-8 Multiple Perimeter Guards Installation Configurations

The scan coding feature of the PA allows for placement of systems in close proximity and in line with each other. The distinctive coding of the beams provide for unique operation of a system while in view of another system with dissimilar scan coding. Three unique codes are available on the PA4600/PA4600BB for these types of applications. See Figure 8-9 for reference.

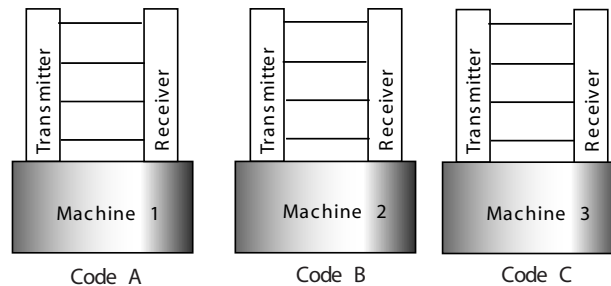

Figure 8-9 Multiple Perimeter Guards Installation Configurations using Scan Coding

Note: In some cases a receiver operating in Scan code B may react if it receives a signal from two transmitters operating on Scan code A and C. The receiver operating in Scan code B will periodically convert from Machine Run to Machine Stop (crosstalk). It is recommended that the receiver operating in Scan code B is positioned so that it is NOT in view of the transmitters on Scan code A and C. A single transmitter operating on Scan code A or C will not affect the operation of the receiver. This is NOT a safety concern, as the receiver will always operate in a safe condition.

8.1.3 ACCESS TO CONFIGURATION SWITCHES

The switches to configure the PA4600/PA4600BB system operating features are located behind the front access cover on the end caps of the receiver (and on the receiver cable end of the transceiver of the PA4600). Reinstall the retaining screw after completing the configuration.

8.1.4 ALIGNMENT

Physical alignment of the PA4600 transmitter (or active and passive units of the PA4600BB) and receiver units is easiest when the PA4600/PA4600BB system is in the automatic start operating mode. The units should be in the same plane and at equal height.

The Individual Beam Indicators will light when a beam is out of alignment. See Section 6.1- Individual Beam Indicators for details.

8.1.5 CABLE ASSEMBLIES

Receiver cable connectors and transmitter cable connectors are available. Details of the pin-out connections for the STI-supplied connector are provided in fig. *Figure 8-10* and *Figure 8-11*.

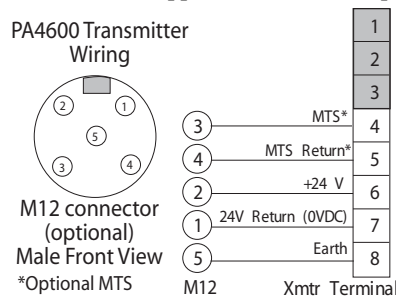

Figure 8-10 Pin Out Diagram for Transmitter Cable

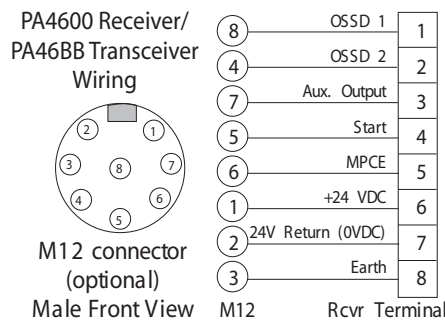

Figure 8-11 Pin Out Diagram for PA4600 Receiver Cable and PA4600BB Transceiver

8.1.6 INPUT POWER REQUIREMENTS/CONNECTIONS

The PA4600/PA4600BB system operates directly from 24 VDC $\pm 20\%$. Power to the 4600 system must come from a dedicated power supply which meets the requirements of IEC 60204-1 and IEC 61496-1, STI part number 42992 or equivalent.

8.1.7 SPECIAL REQUIREMENTS FOR PERIMETER GUARDING

The guarded machine must only be restarted using a switch located outside the detection area and located within full view of the hazardous zone. The PA4600/PA4600BB system's operating mode should be configured in the start/restart interlock mode.

8.1.8 PRESENCE SENSING DEVICE INITIATION

Due to requirements of object resolution, in accordance with ANSI RIA 15.06-1999, OSHA 1910.217(h), and ANSI B11.2-1995, the PA4600/PA4600BB may not be used for Presence Sensing Device Initiation (PSDI).

9 CONNECTING TO THE MACHINE CONTROL CIRCUIT

9

WARNING! This product is designed for use on a 24 VDC, negative ground (functional ground) electrical system only. Never connect the PA4600/PA4600BB system to a positive ground (functional ground) system. With a positive ground wiring scheme, certain simultaneous shorts of both safety outputs may not be detected and the guarded machine may not stop resulting in severe operator injury.

WARNING! Never use only a single safety output to control the machine. Should this single output fail, the machine may not stop, resulting in severe operator injury. The machine must be connected using both safety outputs.

The electrical connections for the PA4600/PA4600BB units are made by removing the larger endcap near the display. With the endcap removed snap out the 8 position terminal block from the endcap piece. Then pass the wires through the endcap wiring port and strain relief plug. Make wiring connections to the numbered terminal block contacts and then snap the terminal block back to the endcap piece. Align the endcap to the housing and secure the four screws.

WARNING! Disconnect power before opening the endcap.

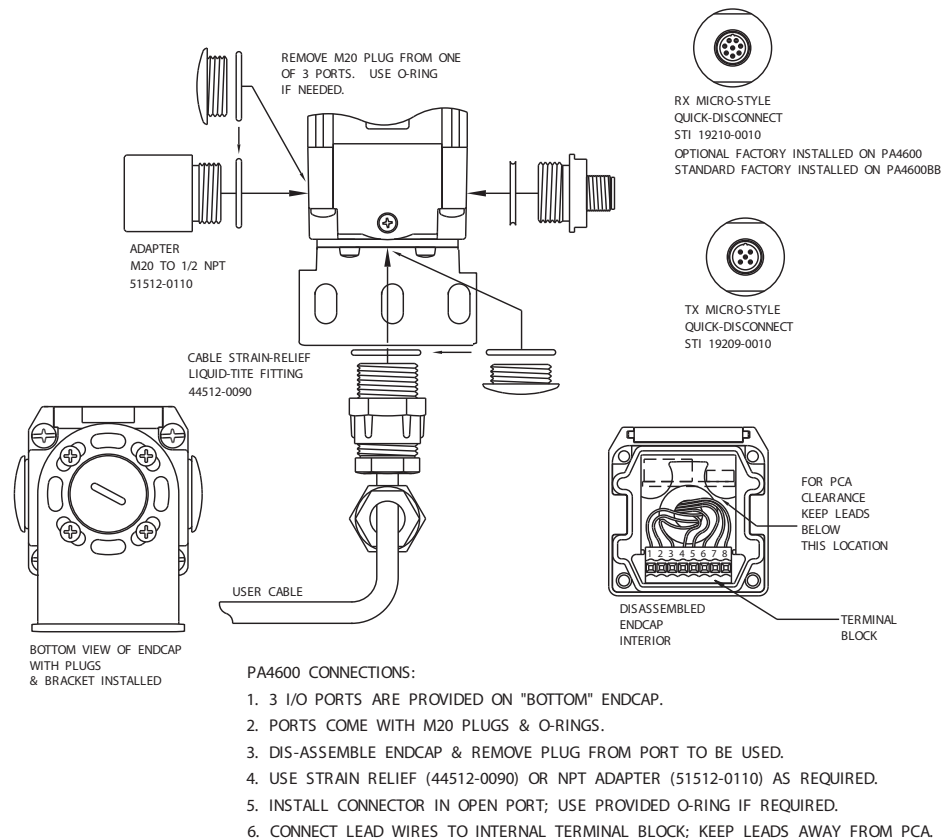

Figure 9-1 Connector Options

9.1 CONNECTING TO A SAFETY MONITORING DEVICE

The wiring from the PA4600/PA4600BB system to the machine control circuit must be control reliable as described in ANSI B11.19-1990. Normally PLCs are not designed to be control reliable. Safety devices such as the PA4600/PA4600BB system should not depend on a PLC to stop a guarded machine.

However, safety related monitoring devices are now available. See *Figure 9-2* for connection to such a device. Note that all safety inputs are directed to the monitoring device which also performs the MPCE monitoring function.

Connecting to Machine Control System Via Safety Monitoring Device

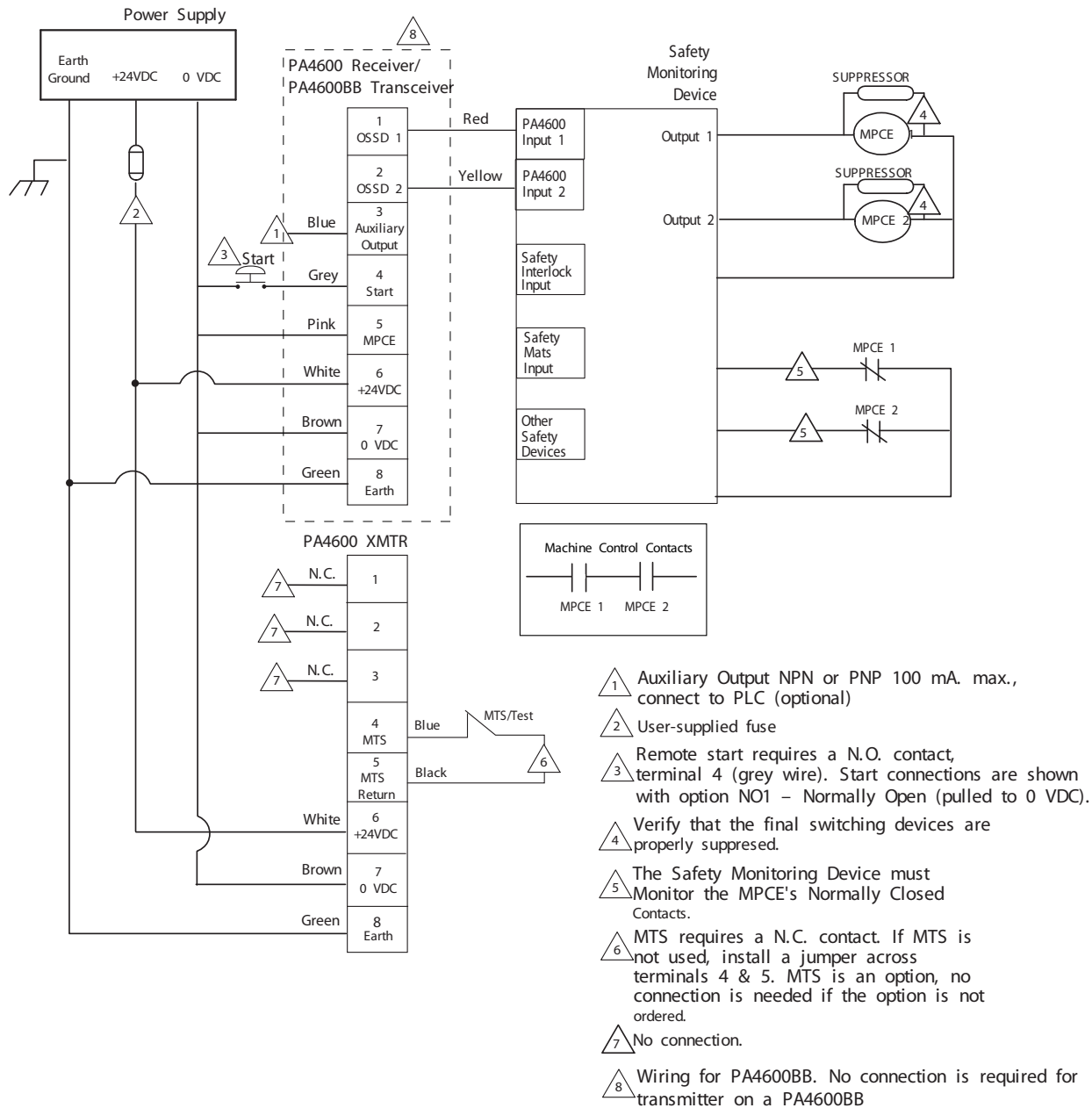

Figure 9-2 Connecting to a Safety Monitoring Device

9.2 CONNECTING VIA AN RM-1 MODULE

The STI RM-1 Module provides force-guided relay outputs for machine control. OSSD Safety outputs 1 and 2 are connected to the RM-1 and provide the power necessary to energize its relays. See *Figure 9-3* for the preferred connection method using the RM-1. The auxiliary non-safety output of the PA4600/PA4600BB system can be used to signal light curtain status to a PLC.

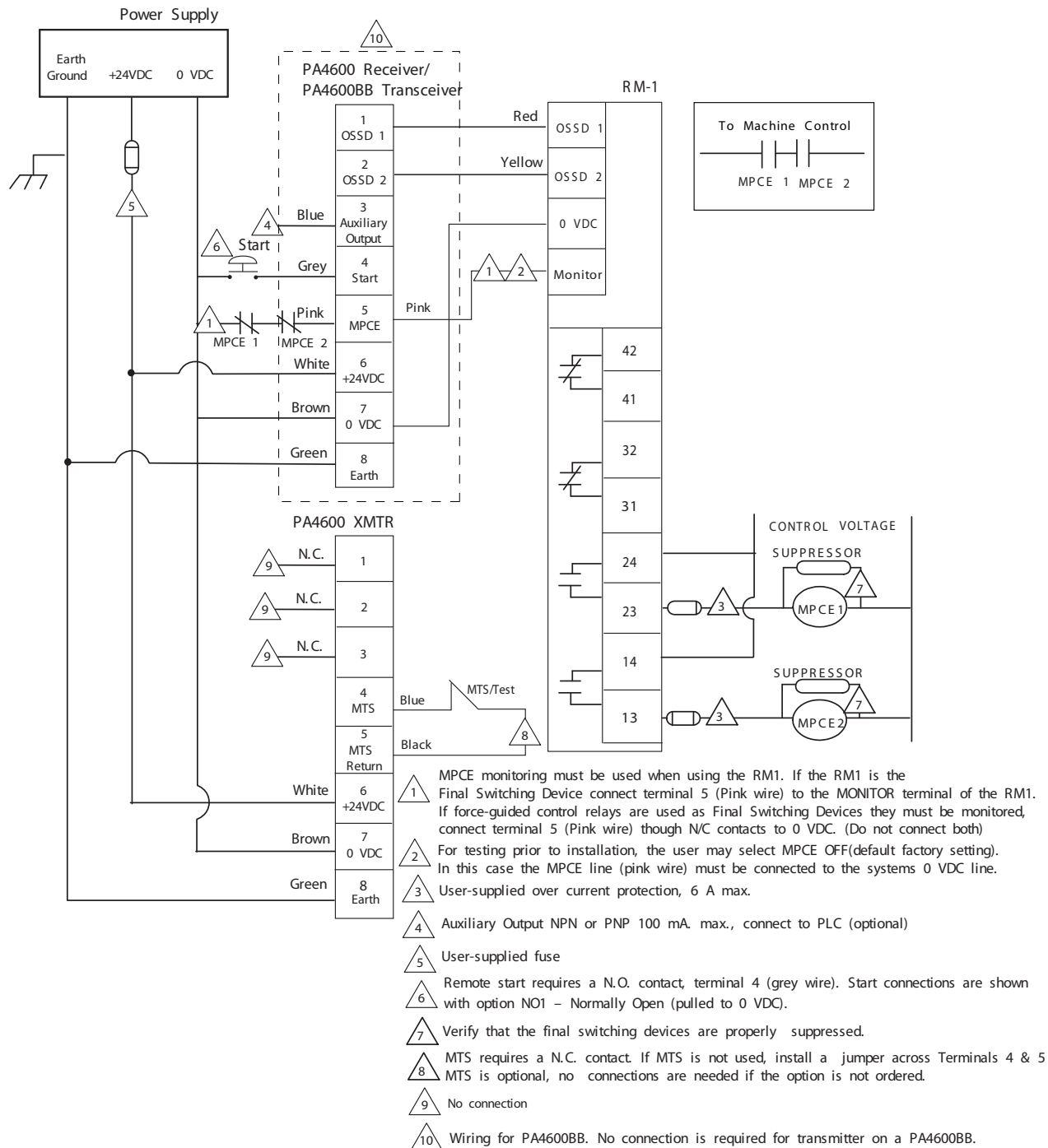

Figure 9-3 Connecting via an RM-1 Module

9.3 CONNECTING VIA TWO FORCE-GUIDED RELAYS

FGR series relays provides force-guided relay outputs for machine control. See *Figure 9-4* for the preferred connection method using two force-guided relays.

Connecting to Machine Control System Via Two Force-Guided Relays

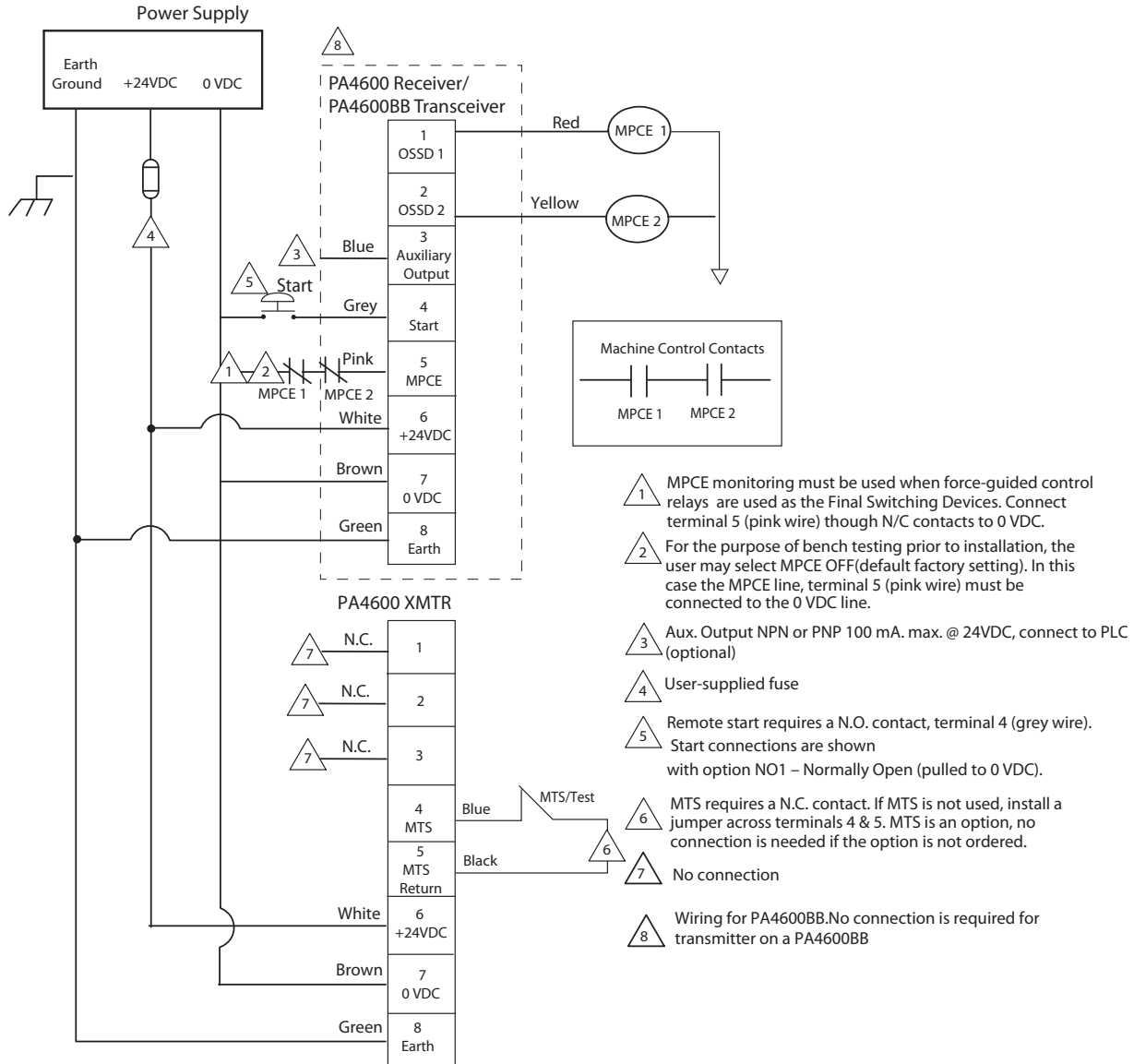

Figure 9-4 Connecting Via Two Force-guided Relays

9.4 CONNECTING TO MACHINE CONTROL SYSTEM VIA RM-2AC

The following example shows the PA4600/PA4600BB interfaced to a RM-2AC via 100 to 240 VAC input.

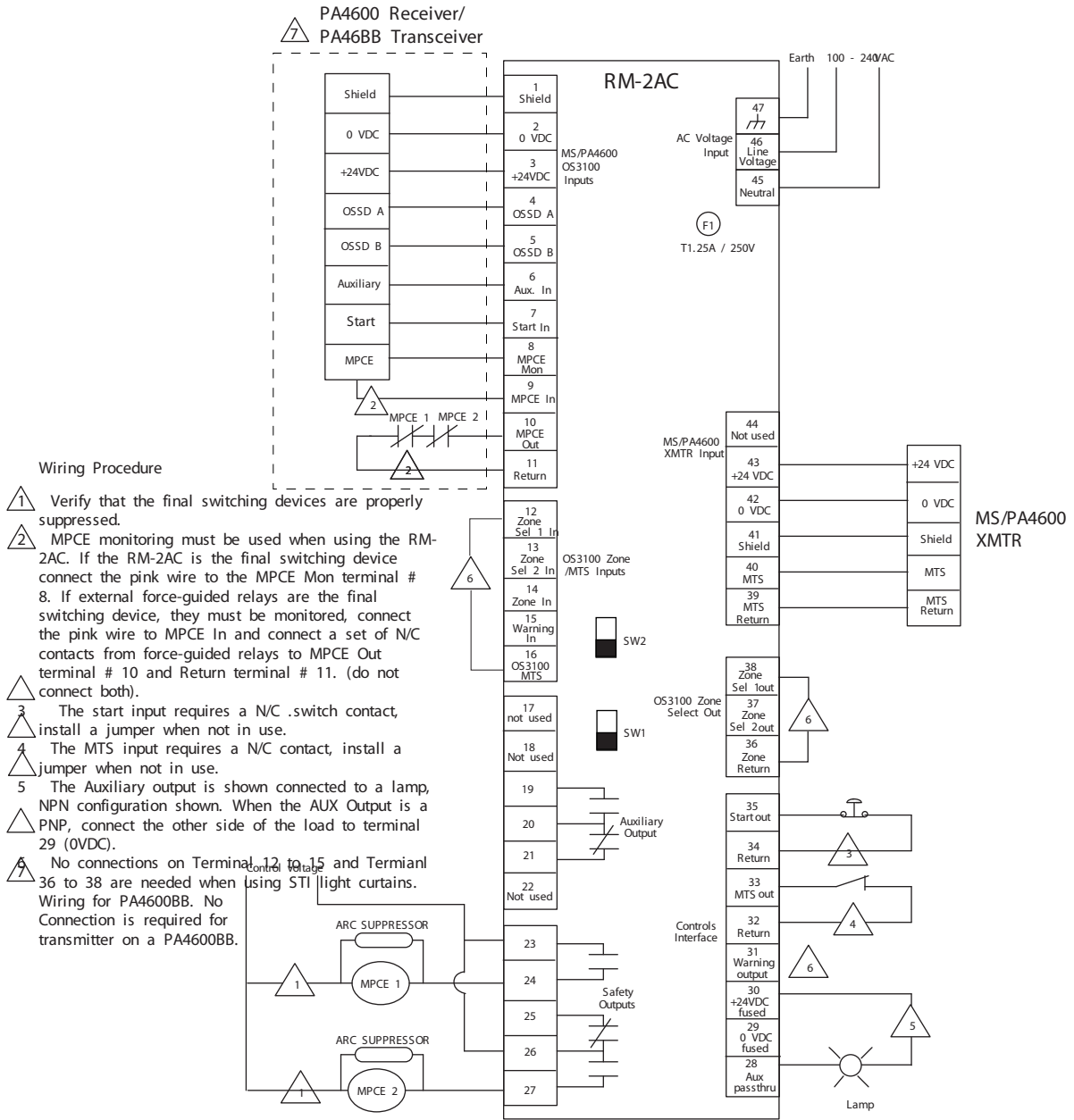
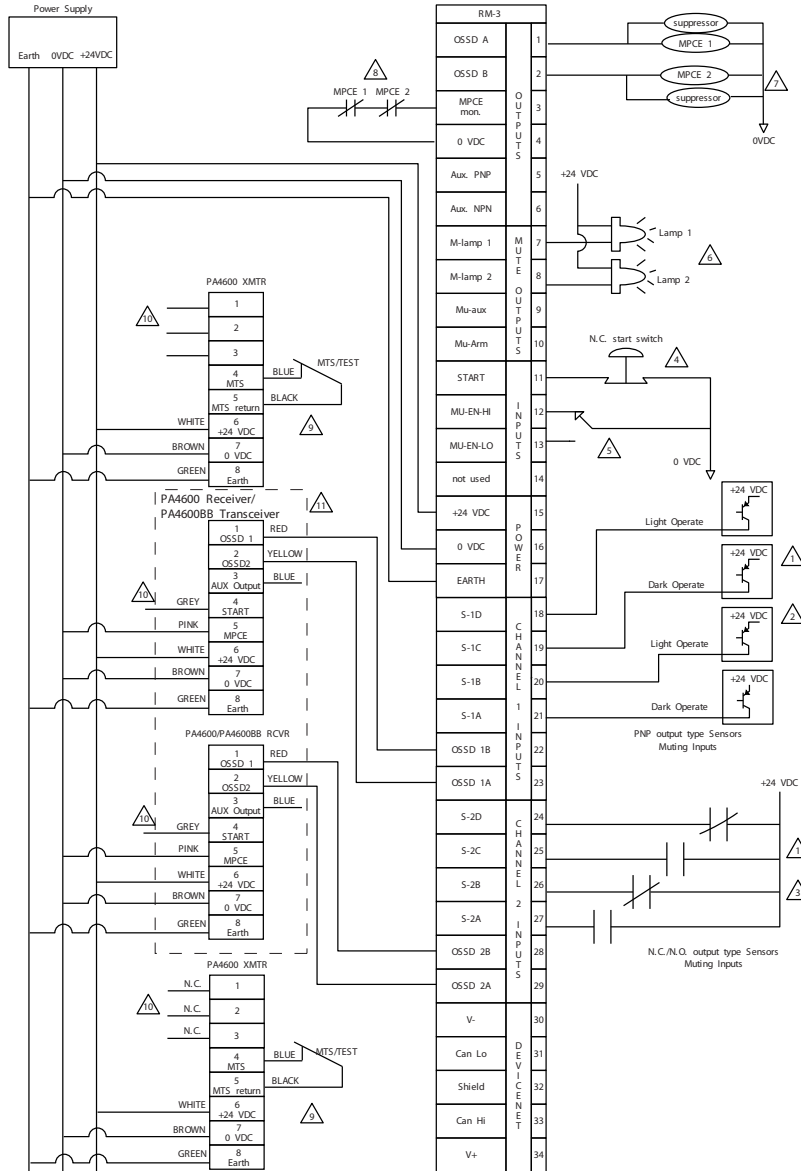

Figure 9-5 Connecting Via RM-2AC

9.5 CONNECTING TO MACHINE CONTROL SYSTEM VIA RM3

The following example shows two PA4600/PA4600BB Perimeter Guarding Devices interfaced to an RM3. The RM3 is muting both the perimeter guards and each has four muting sensors per safety channel. The RM3 is driving two MPCE control relays and monitoring the NC auxiliary contacts. See Figure 9-6.



- NOTES:
- 1. Muting inputs for channels 1 and 2 are shown in the non-mute state.
 - 2. Inputs for channel 1 are PNP-type sensors, light/dark operate.
 - 3. Muting inputs for channel 2 are N.C./N.O. relay output type sensors.
 - 4. The number of muting sensors can be configured for 2, 3 or 4 (application dependent).
 - 5. The start input is Normally Closed; install a jumper if a switch is not needed.
 - 6. Mute enable input is shown in the non-mute state.
 - 7. External mute indicating lamps (rated 40-300 mA @ 30 VDC max.) MUST be used.
 - 8. Verify that the final switching devices are properly suppressed.
 - 9. MPCE monitoring must be used when forced-guided control relays are used as the final switching devices.
 - 10. MPCE monitoring requires a N.C. contact. If MTS is not used, install a jumper across terminals 4 and 5.
 - 11. MTS is an option, no connection is needed if the option is not ordered.
 - 12. No connection.
 - 13. Wiring for PA4600BB. No connection is required for transmitter on a PA4600BB.

Figure 9-6 Connecting Via RM3 Module

10 CHECKOUT AND TEST PROCEDURES

10

10.1 CHECKOUT PROCEDURE

Once the PA4600/PA4600BB system has been configured, mounted, aligned and properly connected to the machine control system, the initial Checkout Procedure detailed in Appendix A must be performed by qualified personnel. A copy of the checkout results should be kept with the machine records.

10.2 TEST PROCEDURE

WARNING! The tests outlined in the Test Procedure in Appendix B must be performed at installation, according to the employer's regular inspection program and after any maintenance, tooling change, set up, adjustment, or modification to the PA4600/PA4600BB system or the guarded machine. Where a guarded machine is used by multiple operators or shifts, it is suggested that the test procedure be performed at each shift or operation change. For any and all installations, OSTI recommends the Test Procedure in Appendix B be performed at least once per year. Testing ensures that the light curtain and the machine control system work properly to stop the machine. Failure to test properly could result in serious injury to personnel.

When using a PA4600/PA4600BB system set for Automatic Start Mode operation, in conjunction with an RM-1 or RM-X relay module, it is necessary to verify that the RM-1 or RM-X outputs can properly change state by causing an intentional beam break at least every change of shift or 24 hours of operation.

11 CLEANING

11

Accumulation of oil, dirt and grease on the front filter of the PA600 transmitter or receiver can affect the system operation. Clean filters with a mild detergent or glass cleaner. Use a clean, soft, lint-free cloth. Painted PA4600/PA4600BB surfaces may be cleaned with a mild de-greasing cleaner or detergent.

12 SPECIFICATIONS AND ADDITIONAL INFORMATION

12.1 SYSTEM SPECIFICATIONS

Performance:	
Protective Height	Variable
Operating Range	0.8 to 70 meter for PA4600, 0.8 to 8m for PA4600BB
Effective Aperture Angle	± 2.5° maximum, transmitter and receiver at operating range greater than 3 meter per IEC 61496-2.
Safety Output	Two PNP, each output sourcing 625 mA @ 24 VDC, short circuit protected. (See note 1)
Response Time	Scan code A: <24 ms Scan code B: <20 ms Scan code C: <16 ms
Auxiliary (Non-Safety) output	One NPN output sinking 100mA @ 24VDC or PNP output sourcing 100 mA @ 24 VDC. Both available in follow or fault operating mode.
MPCE Monitor	50 mA @24 VDC steady state (See Note 2 below.)
Start/Restart	10mA consumption
Light Source	Infrared Light Emitting Diode, 880 nm
Transmitter Indicator Light	Active (Yellow)
Receiver Indicator Light	Machine run (Green), Machine stop (Red), Interlock/Alarm (Yellow), individual beams and two 7-segment display.
Electrical:	
Power input	Transmitter: 24 VDC ± 20% 100 mA max. Receiver: 24 VDC ± 20% 1.6 mA max. (receiver 250mA + OSSD1 625 mA max. + OSSD2 625 mA max. + auxiliary 100 mA max). Power Supply must meet requirements of IEC 60204-1 and IEC 61496. ST1 part number 42992 or equivalent. (See note 1 below).
Mechanical:	
Construction	Polyester powder painted aluminum
Cable length	Available in 10, 15, and 30 m lengths, unshielded.
Wiring Connections	8-contact terminal block for transmitter and receiver and PA4600BB. Optional M12 connectors: 8-pin receiver and PA4600BB & 5-pin transmitter.
Min. Cable Gauge	22 AWG (0.32 mm ²) for user-supplied cables.
Environmental:	
Enclosure rating	IP67
Temperature	0 to 55 degree C (32 to 131 F)
Relative Humidity	95% maximum, non-condensing
Approvals:	CE, TUV, UL and CSA
Conformities:	ESPE Type 4 (IEC 61496-1 /-2) Category 4 / PL e (EN ISO 13849-1) SIL3 / SIL3 CL3 (IEC 51508 / EN 62061) ANSI R15.6-1999, ANSI B11.19-1990, OSHA 1910.217 (c)
Safety Related Parameters:	PFH = 2.7 E-09 1/h Proof Test Interval = 20 years MTTFd = 100 years
Specifications subject to change	
Note 1: Total system current requirements is the sum of transmitter (100mA), receiver (250mA), OSSD1 (625mA), OSSD2 (625mA) and Aux. Output (100mA).	
Note 2: 24 VDC is nominal. Actual voltage is dependant upon supply, V = Vsupply - 2V.	

12.2 INPUTS AND OUTPUTS CABLE LENGTH LIMITATIONS

RX or TX	Signal Name	Minimum Wire Gauge ¹	Specified max. length
RX	OSSD A & B outputs	20 AWG (0.52mm ²) wire	300 mA load: 70 meter (230 ft.) 625 mA load: 35 meter (115 ft.)
RX	Aux output	22 AWG (0.32mm ²) wire	70 meter (230 ft.)
RX	Start input	22 AWG (0.32mm ²) wire	70 meter (230 ft.)
RX	MPCE Monitor input	22 AWG (0.32mm ²) wire	70 meter (230 ft.)
RX	24 VDC input power	18 AWG (0.82mm ²) wire	1.6 Amp load: 20 meter (65 ft.) 1 Amp load: 36 meter (117 ft.)
TX	24 VDC input power	22 AWG (0.32mm ²) wire	0.1 Amp: 120 meter (390 ft.)

12.3 DIMENSIONAL DRAWING

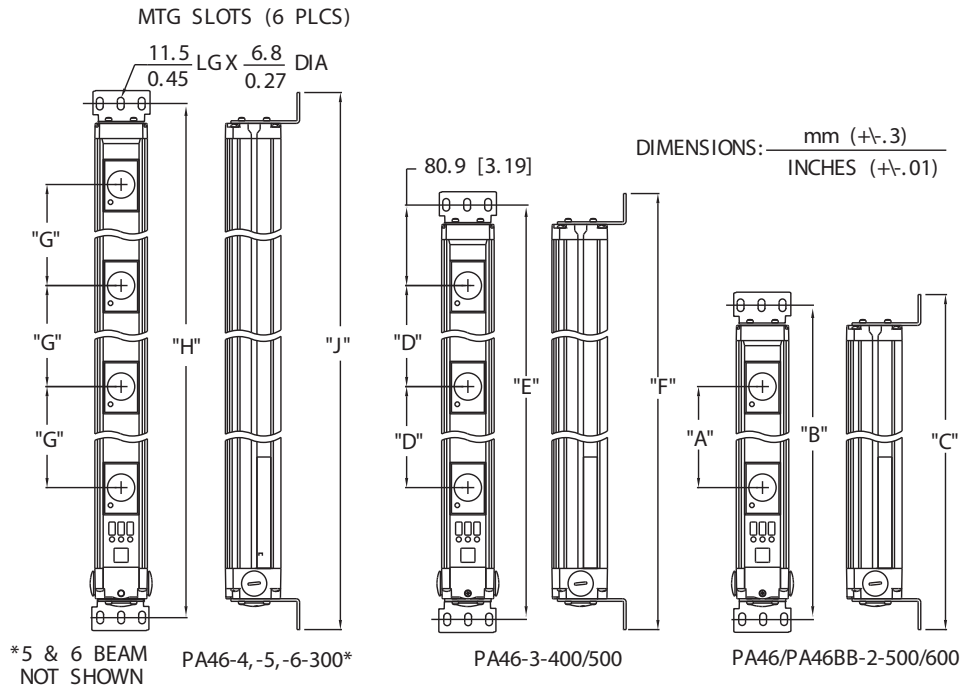

Figure 12-1 PA4600/PA4600BB Dimensional Drawing

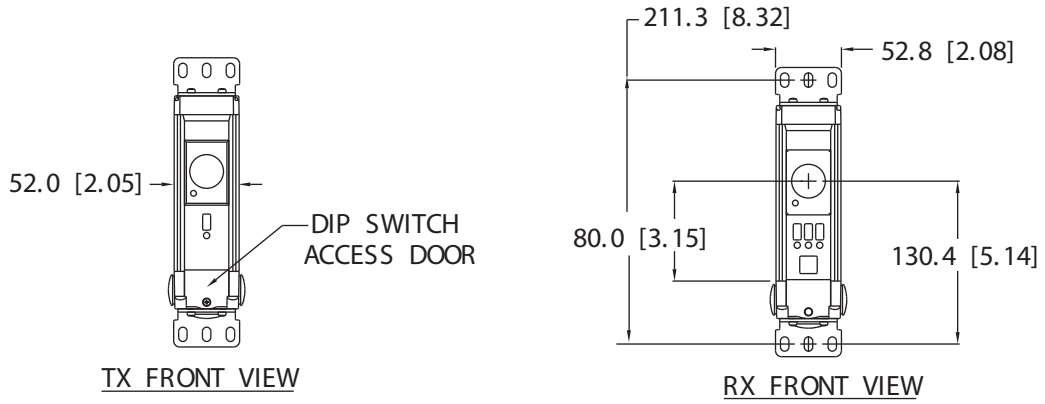

Figure 12-2 Receiver and Transmitter Front View and Mounting Brackets

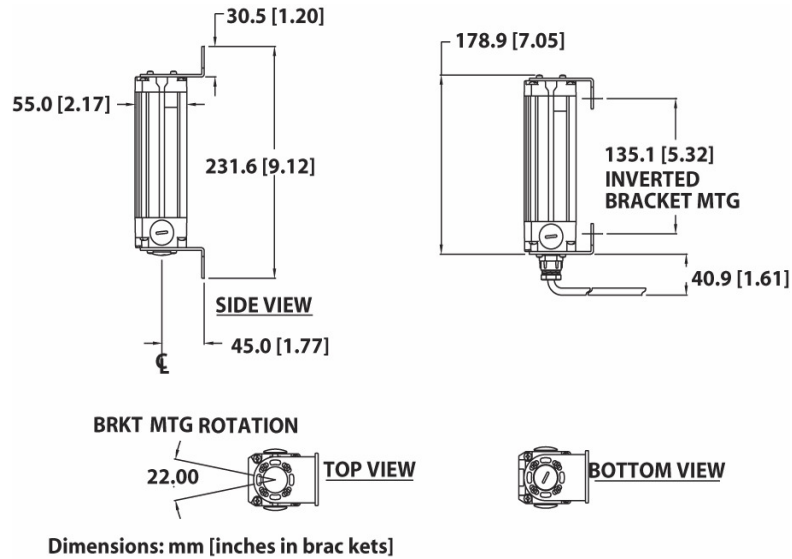

Figure 12-3 Mounting Brackets

Table 12-1 PA4600/PA4600BB Dimensions (mm/inches)

PA46-X	Beam Spacing	Mtg Holes	Overall Height
PA46-1-100	N/A	211.3/8.32	241.1/9.49
PA46-2-500	A = 500/19.69	B = 711.3/28.00	C = 741.1/29.18
PA46-BB-2-500	A = 500/19.69	B=760.8/29.95	C=781.1/30.75
PA46-2-600	A = 600/23.62	B = 811.3/31.94	C = 841.1/33.11
PA46BB-2-600	A=600/23.62	B=860.8/33.89	C=881.1/34.69
PA46-3-400	D = 400/15.75	E = 1011.3/39.81	F = 1041.1/40.99
PA46-3-500	D = 500/19.69	E = 1211.3/47.68	F = 1241.1/48.86
PA46-4-300	G = 300/11.81	H = 1111.3/43.75	J = 1141.1/44.93
PA46-5-300	G = 300/11.81	H = 1411.3/55.56	J = 1431.6/56.36
PA46-6-300	G = 300/11.81	H = 1711.3/67.37	J = 1731.6/68.17



12.4 SPARE PARTS

12.4.1 TRANSMITTERS MODEL NUMBERS

To order a spare transmitter, read the part number from your existing transmitter, or build a model from the options in the table below.

PA46 _____ - _____ - _____
(1) (2) (3)

1) Number of beams and space between beams

1-000 = 1 beam (only)

2-500 = 2 beams spaced at 500 mm

2-600 = 2 beams spaced at 600 mm

3-400 = 3 beams spaced at 400 mm

3-500 = 3 beams spaced at 500 mm

4-300 = 4 beams spaced at 300 mm

5-300 = 5 beams spaced at 300 mm

6-300 = 6 beams spaced at 300 mm

2) Optional M12 Q-D connector

Q2 = M12 Quick- Disconnect

Blank = no Quick- Disconnect

3) Optional MTS

M = MTS

Blank = No MTS

12.4.2 RECEIVERS MODEL NUMBERS

To order a spare receiver, read the part number from your existing receiver, or build a model from the options in the table below.

PA46 _____ - _____ - _____ - _____
(1) (2) (3) (4)

1) Number of beams and space between beams

1-000 = 1 beam (only)

2-500 = 2 beams spaced at 500 mm

2-600 = 2 beams spaced at 600 mm

3-400 = 3 beams spaced at 400 mm

3-500 = 3 beams spaced at 500 mm

4-300 = 4 beams spaced at 300 mm

5-300 = 5 beams spaced at 300 mm

6-300 = 6 beams spaced at 300 mm

2) Optional M12 Q-D connector

Q2 = M12 Quick- Disconnect

Blank = no Quick- Disconnect

3) Information Required. Represents the Start/Restart input type.

Designator	Description
- NO1	Normally open (pulled low to 0 VDC)
- NO2	Normally open (pulled high to +24 VDC)
- NC1	Normally closed (pulled low to 0 VDC)
- NC2	Normally closed (pulled high to +24 VDC)

4) Auxiliary Output Configuration

N = NPN

P = PNP

12.4.3 PA4600BB TRANSCEIVER

PA46-BB-2-_____

Beam Spacing

500 = 2 beams at 500mm spacing

600 = 3 beams at 600mm spacing

12.4.4 PA4600BB PASSIVE

PA46-BB-2-500-MIRW

PA46-BB-2- 600 MIRW



12.4.5 CABLES

Receiver Cables	Description
60672-0100	10m receiver/transceiver cable
60672-0150	15m receiver/transceiver cable
60672-0300	30m receiver/transceiver cable
19210-0010	M12 receiver connector
Transmitter Cables	Description
60673-0100	10m transmitter cable
60673-0150	15m transmitter cable
60673-0300	30m transmitter cable
19209-0010	M12 transmitter connector

12.4.6 OTHERS

Model Number/Part Number	Description
LCMK-4	Mounting Kit - allows mounting to STI stands
PAMK-36	PA46 36 in. mounting stand
PAMK-40	PA46 40 in. mounting stand
PAMK-44	PA46 44in. mounting stand
PAMK-48	PA46 48in. mounting stand
PAMK-52	PA46 52in. mounting stand
43695-0010	4 x 5 Mirror
25623	Mirror Mounting Kit
42338-0040	4 ft. mounting stand
42338-0060	6 ft. mounting stand
42338-0070	7 ft. mounting stand
42338-0080	8 ft. mounting stand
42338-0100	10 ft. mounting stand
40348-0010	Laser Alignment Tool

12.5 WARRANTY

OMRON STI warrants its products to be free from defects of material and workmanship and will, without charge, replace or repair any equipment found defective upon inspection at its factory, provided the equipment has been returned, transportation prepaid, within one year from the date of installation and not to exceed 18 months from date of factory shipment.

The foregoing warranty is in lieu of and excludes all other warranties not expressly set forth herein, whether expressed or implied by operation of law or otherwise including but not limited to any implied warranties of merchantability or fitness for a particular purpose. No representation or warranty, express or implied, made by any sales representative, distributor, or other agent or representative of OMRON STI which is not specifically set forth herein shall be binding upon OMRON STI. OMRON STI shall not be liable for any incidental or consequential damages, losses or expenses directly or indirectly arising from the sale, handling, improper application or use of the goods or from any other cause relating thereto and OMRON STI's liability hereunder, in any case, is expressly limited to repair or replacement (at OMRON STI's option) of goods.

Warranty is specifically at the factory or an OMRON STI authorized service location. Any on site service will be provided at the sole expense of the Purchaser at standard field service rates. All associated equipment must be protected by properly rated electronic/electrical protection devices. OMRON STI shall not be liable for any damage due to improper engineering or installation by the purchaser or third parties. Proper installation, operation and maintenance of the product becomes the responsibility of the user upon receipt of the product.

12.6 PATENTS

Elements of the electronics and optics essential to meet the specifications and performance standards of OMRON STI controls are covered by one or more of the following U.S. Patent Numbers: 3,774,039; 3,867,628; 3,967,111; 3,996,476; 4,007,387; 4,101,784; 5,015,840; Design 255,031, and other patents pending.

12.7 TRADEMARKS

PA4600/PA4600BB is a trademark of OMRON Scientific Technologies, Inc.

12.8 REPAIRS

OMRON STI offers product repair service at our factory. If you need repairs made to any OMRON STI product contact our Customer Service Department.

12.9 DOCUMENTATION CRITERIA

This publication has been carefully checked for accuracy and is believed to be fully consistent with the products it describes. However, OMRON STI does not assume liability for the contents of this publication, the examples used within, or the use of any product described herein. OMRON STI reserves the right to make changes to products and/or documentation without further notification.



13 GLOSSARY

13.1 GLOSSARY DEFINITIONS

Detection Zone: The sensing zone between the transmitter and receiver where objects will be detected by the PA4600/PA4600BB system.

MPCE: The electrically powered element that directly controls the normal operation of a machine in such a way that it is the last (in time) to function when machine operation is to be initiated or arrested.

OFF State: The state in which the output circuit is interrupted and does not permit current to flow.

ON State: The state in which the output circuit is complete and permits the flow of current.

Output Signal Switching Device (OSSD): The component of the safety light curtain connected to the machine control system which, when the light curtain detection zone is interrupted, responds by going to the OFF state. Also known as safety outputs.

14 TROUBLESHOOTING

14.1 RECEIVER INDICATOR LIGHTS

14.1.1 RECEIVER TROUBLESHOOTING

The PA4600/PA4600BB receiver unit has a two-digit numeric display that displays diagnostic codes identified by the internal control circuits. This display is visible from the front of the receiver. The diagnostic codes used in the PA4600/PA4600BB are given in the following table.

Table 14-1 Diagnostic Code Listing

Code Group	Code Number	Meaning of Diagnostic Code
Normal Operation	88/V#	During Power-Up all of the segments are light and then the software version number is displayed.
	--	RUN state
	- 0	STOP state
	- 1	In the Interlock state and waiting for Start Input
Dipswitch Faults	21	Invalid Mode selection setting.
	22	Dipswitch settings changed during operation.
	26	Invalid Code setting
Safety Output (OSSD) Faults	31	Safety Output A & B are shorted together.
	32	Safety Output A shorted to Power.
	33	Safety Output B shorted to Power.
	34	Safety Output A shorted to Ground.
	35	Safety Output B shorted to Ground.
MPCE Faults	41	MPCE signal was in Wrong state BEFORE entering the Machine RUN state.
	42	MPCE signal was in Wrong state AFTER entering the Machine RUN state.
	43	MPCE signal was in Wrong state during power-up of the PA4600/PA4600BB.
Receiver Fault	50	A fault internal to the PA4600/PA4600BB has been detected.
Setup Error	60	Receiver in view of multiple transmitters set to the same scan code.

14.2 TRANSMITTER INDICATOR LIGHT

- Yellow - The Transmitter is active. If the LED is blinking, the light curtain is in an alarm condition.

14.2.1 TROUBLESHOOTING THE TRANSMITTER

If the yellow LED is off:

1. Verify the cable is connected.
2. Verify the power supply is within limits (+24V ± 20%).
3. MTS connected to MTS Return, see Section 5-- *Diagnostic and Test Features*
4. Call OMRON STI's Service Department @ 1/888/510-4357.

If the yellow LED is blinking:

1. Verify the power supply is within limits (+24V ± 20%).
2. Call OMRON STI's Service Department @ 1/888/510-4357.



APPENDIX A —CHECKOUT PROCEDURE

A.1 CHECKOUT PROCEDURE LOG

Qualified personnel during initial PA4600/PA4600BB system installation and at least every three months or more frequently depending on machine usage and company guidelines must perform the following checkout procedure.

Machine Identification: _____ Date: _____

Item	Condition	Comments
1. Verify that the guarded machine is compatible with the type of machine which maybe used with the 4600 system. See Section 1-- <i>Important Safety Warnings</i> for further information.	<input type="checkbox"/> Pass <input type="checkbox"/> Fail	
2. Verify that the mounting distance of the PA4600/PA4600BB system is equal to or greater than the minimum safe distance from the danger point. See Section 7-- <i>Safe Mounting Distance</i> for further information.	<input type="checkbox"/> Pass <input type="checkbox"/> Fail	
3. Determine that all access to the danger point not protected by the PA4600/PA4600BB system is guarded by other means, such as gates, fencing or other approved methods. Verify that all additional guarding devices are installed and operating properly.	<input type="checkbox"/> Pass <input type="checkbox"/> Fail	
4. Verify that the PA4600/PA4600BB can only be reset from a position outside and within view of the hazardous machine area. If not, then make sure the operator is not able to stand outside of view within the hazardous area without supplemental guarding such as gates, fencing or other approved methods.	<input type="checkbox"/> Pass <input type="checkbox"/> Fail	
5. Inspect the electrical connections between the guarded machine's control system and the PA4600/PA4600BB system. Verify that they are properly connected to the machine such that a stop signal from the PA4600/PA4600BB system results in an immediate halt of the machine's cycle. See Section 9-- <i>Connecting to The Machine Control Circuit</i> .	<input type="checkbox"/> Pass <input type="checkbox"/> Fail	
6. If the MPCE monitoring feature is not used, proceed to step 7. To test the MPCE feature, verify that the feature has been enabled. Turn the machine power on. Cycle the machine. Place a temporary jumper wire between the MPCE connections. The PA4600/PA4600BB should enter an alarm condition. Remove the temporary jumper. Press and release the start button.	<input type="checkbox"/> Pass <input type="checkbox"/> Fail	
7. Record the test results in the machine log, then perform the Test Procedure.	<input type="checkbox"/> Pass <input type="checkbox"/> Fail	

Technician
Signature: _____

APPENDIX B —TEST PROCEDURE

B.1 TEST PROCEDURE LOG

The following test procedure must be performed by qualified personnel during initial PA4600/PA4600BB system installation, according to the employer's regular inspection program and after any maintenance, adjustment or modification to the PA4600/PA4600BB system or the guarded machine. Testing ensures that the light curtain, safety system, and machine control system work together to properly stop the machine. Failure to test properly could result in serious injury to personnel. To test the PA4600/PA4600BB system, use a test object larger than the single beam being blocked.

Machine Identification: _____ Date: _____

Item	Condition	Comments
1. Disable the guarded machine. Apply power to the PA4600/PA4600BB system.	<input type="checkbox"/> Pass <input type="checkbox"/> Fail	
2. Visually inspect the machine to ensure that access to the danger point is only through the PA4600/PA4600BB detection zone. If not, additional guarding, including mechanical barriers may be required. Verify that all additional guarding devices and barriers are installed and operating properly.	<input type="checkbox"/> Pass <input type="checkbox"/> Fail	
3. Verify that the mounting distance of the PA4600/PA4600BB system is equal to or greater than the calculated minimum safety distance from the danger point. See Section 7-- <i>Safe Mounting Distance</i> for further information. Ensure that the operator is not able to stand between the PAA4600 detection zone and the danger point without being in clear view of the reset location.	<input type="checkbox"/> Pass <input type="checkbox"/> Fail	
4. Check for signs of external damage to the PA4600/PA4600BB system, the machine and the electrical cables and wiring. If damage is found, lock the machine off and report to the supervisor.	<input type="checkbox"/> Pass <input type="checkbox"/> Fail	
5. Interrupt all individual beams of the PA4600/PA4600BB system detection zone. Each corresponding Individual Beam Indicator must be lit when its beam is being blocked. If in automatic start mode, verify that the red machine start light is lit. If in start/restart interlock mode, verify that the red machine stop and yellow interlock lights are on. Press and release start button before proceeding to step 6	<input type="checkbox"/> Pass <input type="checkbox"/> Fail	
6. Start the machine. While the machine is in motion, interrupt a beam within the detection zone. The machine should stop immediately. Never insert a test object into the dangerous parts of the machine. With the machine at rest, interrupt the detection zone with a test object. Verify that the machine will not start with a test object blocking a beam within the detection zone.	<input type="checkbox"/> Pass <input type="checkbox"/> Fail	
7. Verify that the braking system is working properly. If the machine does not stop fast enough, adjust the braking system or increase the distance from the detection zone to the danger point.	<input type="checkbox"/> Pass <input type="checkbox"/> Fail	
8. If the safety devices or the machine fails any of these tests, do not run the machine. Immediately tag or lockout the machine to prevent its use and notify the supervisor.	<input type="checkbox"/> Pass <input type="checkbox"/> Fail	

Technician

Signature: _____



APPENDIX C —DECLARATION OF COMFORMITY INFORMATION

OMRON SCIENTIFIC TECHNOLOGIES INCORPORATED

OMRON Scientific Technologies Incorporated (at 6550 Dumbarton Circle, Fremont, CA 94555-3605, U.S.A.), hereby declares that the following series manufactured products listed below conform with the relevant Essential Health and Safety Requirements (EHSRs) of the European **Machinery Directive** (06/42/EC), with the relevant requirements of the **Low Voltage Directive** (06/95/EC), with the essential protection requirements of the **Electromagnetic Compatibility (EMC) Directive** (2004/108/EC), and with the **RoHS Directive** (2002/95/EC) - the restriction of the use of certain hazardous substances in electrical and electronic equipment.

Perimeter Access PA4600 Series (Single & Multiple Beam Safeguard)

Electro-sensitive protection equipment (ESPE) for perimeter access and area guarding, Type 4

The PA4600 Series products have been type-examined per

EC Type Examination Certificate, **Registration No.: 01/205/0733/10**

issued by notified body TUV Rheinland Industrie Service GmbH, Certification Body for Machinery (NB No. 0035).

The following transposed harmonized European and IEC Standards were used to form the basis for the requirements and tests:

EN 61496-1:2004 + 2008 - Safety of machinery – Electro Sensitive Protective Equipment, Part 1: General requirements and tests.

IEC 61496-2:2006 - Safety of machinery – Electro Sensitive Protective Equipment, Part 2: Particular Requirements using Optoelectronic Protective Devices.

EN ISO 13849-1:2008 - Safety of machinery – Safety-related parts of control systems, Part 1: General principle for design.

EN 60204-1:2006: Safety of machinery – Electrical equipment of machines, Part 1: General requirements.

EN 50178:1997: Electronic equipment for use in power installations.

IEC 61508, Parts 1 – 7:1999 – 2000 - Functional Safety Of Electrical/Electronic/Programmable electronic Safety-Related Systems.

EN 62061:2005 – Safety of machinery. Functional safety of safety-related electrical, electronic and programmable electronic control systems.

Martin D. Krikorian
Quality Director
OMRON Scientific Technologies, Inc.
Fremont, CA, USA
April 2010

EU Representative:
Stefan Richter, Chief Engineer Research & Development
OMRON Scientific Technologies, Inc.
Am Garrock 8
D-33154 Salzkotten
Germany
Tel: +49-5258-9327-44
Fax: +49-5258-9327-99

Terms and Conditions of Sale

1. **Offer; Acceptance.** These terms and conditions (these "**Terms**") are deemed part of all quotes, agreements, purchase orders, acknowledgments, price lists, catalogs, manuals, brochures and other documents, whether electronic or in writing, relating to the sale of products or services (collectively, the "**Products**") by Omron Electronics LLC and its subsidiary companies ("**Omron**"). Omron objects to any terms or conditions proposed in Buyer's purchase order or other documents which are inconsistent with, or in addition to, these Terms.
2. **Prices; Payment Terms.** All prices stated are current, subject to change without notice by Omron. Omron reserves the right to increase or decrease prices on any unshipped portions of outstanding orders. Payments for Products are due net 30 days unless otherwise stated in the invoice.
3. **Discounts.** Cash discounts, if any, will apply only on the net amount of invoices sent to Buyer after deducting transportation charges, taxes and duties, and will be allowed only if (i) the invoice is paid according to Omron's payment terms and (ii) Buyer has no past due amounts.
4. **Interest.** Omron, at its option, may charge Buyer 1-1/2% interest per month or the maximum legal rate, whichever is less, on any balance not paid within the stated terms.
5. **Orders.** Omron will accept no order less than \$200 net billing.
6. **Governmental Approvals.** Buyer shall be responsible for, and shall bear all costs involved in, obtaining any government approvals required for the importation or sale of the Products.
7. **Taxes.** All taxes, duties and other governmental charges (other than general real property and income taxes), including any interest or penalties thereon, imposed directly or indirectly on Omron or required to be collected directly or indirectly by Omron for the manufacture, production, sale, delivery, importation, consumption or use of the Products sold hereunder (including customs duties and sales, excise, use, turnover and license taxes) shall be charged to and remitted by Buyer to Omron.
8. **Financial.** If the financial position of Buyer at any time becomes unsatisfactory to Omron, Omron reserves the right to stop shipments or require satisfactory security or payment in advance. If Buyer fails to make payment or otherwise comply with these Terms or any related agreement, Omron may (without liability and in addition to other remedies) cancel any unshipped portion of Products sold hereunder and stop any Products in transit until Buyer pays all amounts, including amounts payable hereunder, whether or not then due, which are owing to it by Buyer. Buyer shall in any event remain liable for all unpaid accounts.
9. **Cancellation; Etc.** Orders are not subject to rescheduling or cancellation unless Buyer indemnifies Omron against all related costs or expenses.
10. **Force Majeure.** Omron shall not be liable for any delay or failure in delivery resulting from causes beyond its control, including earthquakes, fires, floods, strikes or other labor disputes, shortage of labor or materials, accidents to machinery, acts of sabotage, riots, delay in or lack of transportation or the requirements of any government authority.
11. **Shipping; Delivery.** Unless otherwise expressly agreed in writing by Omron:
 - a. Shipments shall be by a carrier selected by Omron; Omron will not drop ship except in "break down" situations.
 - b. Such carrier shall act as the agent of Buyer and delivery to such carrier shall constitute delivery to Buyer;
 - c. All sales and shipments of Products shall be FOB shipping point (unless otherwise stated in writing by Omron), at which point title and risk of loss shall pass from Omron to Buyer; provided that Omron shall retain a security interest in the Products until the full purchase price is paid;
 - d. Delivery and shipping dates are estimates only; and
 - e. Omron will package Products as it deems proper for protection against normal handling and extra charges apply to special conditions.
12. **Claims.** Any claim by Buyer against Omron for shortage or damage to the Products occurring before delivery to the carrier must be presented in writing to Omron within 30 days of receipt of shipment and include the original transportation bill signed by the carrier noting that the carrier received the Products from Omron in the condition claimed.
13. **Warranties.** (a) **Exclusive Warranty.** Omron's exclusive warranty is that the Products will be free from defects in materials and workmanship for a period of twelve months from the date of sale by Omron (or such other period expressed in writing by Omron). Omron disclaims all other warranties, express or implied. (b) **Limitations.** OMRON MAKES NO WARRANTY OR REPRESENTATION, EXPRESS OR IMPLIED, ABOUT NON-INFRINGEMENT, MERCHANTABILITY OR FITNESS FOR A PARTICULAR PURPOSE OF THE PRODUCTS. BUYER ACKNOWLEDGES THAT IT ALONE HAS DETERMINED THAT THE PRODUCTS WILL SUITABLY MEET THE REQUIREMENTS OF THEIR INTENDED USE. Omron further disclaims all warranties and responsibility of any type for claims or expenses based on infringement by the Products or otherwise of any intellectual property right. (c) **Buyer Remedy.** Omron's sole obligation hereunder shall be, at Omron's election, to (i) replace (in the form originally shipped with Buyer responsible for labor charges for removal or replacement thereof) the non-complying Product, (ii) repair the non-complying Product, or (iii) repay or credit Buyer an amount equal to the purchase price of the non-complying Product; provided that in no event shall Omron be responsible for warranty, repair, indemnity or any other claims or expenses regarding the Products unless Omron's analysis confirms that the Products were properly handled, stored, installed and maintained and not subject to contamination, abuse, misuse or inappropriate modification. Return of any Products by Buyer must be approved in writing by Omron before shipment. Omron Companies shall not be liable for the suitability or unsuitability or the results from the use of Products in combination with any electrical or electronic components, circuits, system assemblies or any other materials or substances or environments. Any advice, recommendations or information given orally or in writing, are not to be construed as an amendment or addition to the above warranty. See <http://www.omron247.com> or contact your Omron representative for published information.
14. **Limitation on Liability; Etc.** OMRON COMPANIES SHALL NOT BE LIABLE FOR SPECIAL, INDIRECT, INCIDENTAL, OR CONSEQUENTIAL DAMAGES, LOSS OF PROFITS OR PRODUCTION OR COMMERCIAL LOSS IN ANY WAY CONNECTED WITH THE PRODUCTS, WHETHER SUCH CLAIM IS BASED IN CONTRACT, WARRANTY, NEGLIGENCE OR STRICT LIABILITY. Further, in no event shall liability of Omron Companies exceed the individual price of the Product on which liability is asserted.
15. **Indemnities.** Buyer shall indemnify and hold harmless Omron Companies and their employees from and against all liabilities, losses, claims, costs and expenses (including attorney's fees and expenses) related to any claim, investigation, litigation or proceeding (whether or not Omron is a party) which arises or is alleged to arise from Buyer's acts or omissions under these Terms or in any way with respect to the Products. Without limiting the foregoing, Buyer (at its own expense) shall indemnify and hold harmless Omron and defend or settle any action brought against such Companies to the extent based on a claim that any Product made to Buyer specifications infringed intellectual property rights of another party.
16. **Property; Confidentiality.** Any intellectual property in the Products is the exclusive property of Omron Companies and Buyer shall not attempt to duplicate it in any way without the written permission of Omron. Notwithstanding any charges to Buyer for engineering or tooling, all engineering and tooling shall remain the exclusive property of Omron. All information and materials supplied by Omron to Buyer relating to the Products are confidential and proprietary, and Buyer shall limit distribution thereof to its trusted employees and strictly prevent disclosure to any third party.
17. **Export Controls.** Buyer shall comply with all applicable laws, regulations and licenses regarding (i) export of products or information; (ii) sale of products to "forbidden" or other proscribed persons; and (iii) disclosure to non-citizens of regulated technology or information.
18. **Miscellaneous.** (a) **Waiver.** No failure or delay by Omron in exercising any right and no course of dealing between Buyer and Omron shall operate as a waiver of rights by Omron. (b) **Assignment.** Buyer may not assign its rights hereunder without Omron's written consent. (c) **Law.** These Terms are governed by the law of the jurisdiction of the home office of the Omron company from which Buyer is purchasing the Products (without regard to conflict of law principles). (d) **Amendment.** These Terms constitute the entire agreement between Buyer and Omron relating to the Products, and no provision may be changed or waived unless in writing signed by the parties. (e) **Severability.** If any provision hereof is rendered ineffective or invalid, such provision shall not invalidate any other provision. (f) **Setoff.** Buyer shall have no right to set off any amounts against the amount owing in respect of this invoice. (g) **Definitions.** As used herein, "including" means "including without limitation"; and "Omron Companies" (or similar words) mean Omron Corporation and any direct or indirect subsidiary or affiliate thereof.

Certain Precautions on Specifications and Use

1. **Suitability of Use.** Omron Companies shall not be responsible for conformity with any standards, codes or regulations which apply to the combination of the Product in the Buyer's application or use of the Product. At Buyer's request, Omron will provide applicable third party certification documents identifying ratings and limitations of use which apply to the Product. This information by itself is not sufficient for a complete determination of the suitability of the Product in combination with the end product, machine, system, or other application or use. Buyer shall be solely responsible for determining appropriateness of the particular Product with respect to Buyer's application, product or system. Buyer shall take application responsibility in all cases but the following is a non-exhaustive list of applications for which particular attention must be given: (i) Outdoor use, uses involving potential chemical contamination or electrical interference, or conditions or uses not described in this document. (ii) Use in consumer products or any use in significant quantities. (iii) Energy control systems, combustion systems, railroad systems, aviation systems, medical equipment, amusement machines, vehicles, safety equipment, and installations subject to separate industry or government regulations. (iv) Systems, machines and equipment that could present a risk to life or property. Please know and observe all prohibitions of use applicable to this Product. NEVER USE THE PRODUCT FOR AN APPLICATION INVOLVING SERIOUS RISK TO LIFE OR PROPERTY OR IN LARGE QUANTITIES WITHOUT ENSURING THAT THE SYSTEM AS A WHOLE HAS BEEN DESIGNED TO ADDRESS THE RISKS, AND THAT THE OMRON'S PRODUCT IS PROPERLY RATED AND INSTALLED FOR THE INTENDED USE WITHIN THE OVERALL EQUIPMENT OR SYSTEM.
2. **Programmable Products.** Omron Companies shall not be responsible for the user's programming of a programmable Product, or any consequence thereof.
3. **Performance Data.** Data presented in Omron Company websites, catalogs and other materials is provided as a guide for the user in determining suitability and does not constitute a warranty. It may represent the result of Omron's test conditions, and the user must correlate it to actual application requirements. Actual performance is subject to the Omron's Warranty and Limitations of Liability.
4. **Change in Specifications.** Product specifications and accessories may be changed at any time based on improvements and other reasons. It is our practice to change part numbers when published ratings or features are changed, or when significant construction changes are made. However, some specifications of the Product may be changed without any notice. When in doubt, special part numbers may be assigned to fix or establish key specifications for your application. Please consult with your Omron's representative at any time to confirm actual specifications of purchased Product.
5. **Errors and Omissions.** Information presented by Omron Companies has been checked and is believed to be accurate; however, no responsibility is assumed for clerical, typographical or proofreading errors or omissions.

OMRON AUTOMATION AND SAFETY • THE AMERICAS HEADQUARTERS • Hoffman Estates, IL USA • 847.843.7900 • 800.556.6766 • www.omron247.com

OMRON CANADA, INC. • HEAD OFFICE

Toronto, ON, Canada • 416.286.6465 • 866.986.6766 • www.omron247.com

OMRON ELECTRONICS DE MEXICO • HEAD OFFICE

México DF • 52.55.59.01.43.00 • 01-800-226-6766 • mela@omron.com

OMRON ELECTRONICS DE MEXICO • SALES OFFICE

Apodaca, N.L. • 52.81.11.56.99.20 • 01-800-226-6766 • mela@omron.com

OMRON ELETRÔNICA DO BRASIL LTDA • HEAD OFFICE

São Paulo, SP, Brasil • 55.11.2101.6300 • www.omron.com.br

OMRON ARGENTINA • SALES OFFICE

Cono Sur • 54.11.4783.5300

OMRON CHILE • SALES OFFICE

Santiago • 56.9.9917.3920

OTHER OMRON LATIN AMERICA SALES

54.11.4783.5300

OMRON EUROPE B.V. • Wegalaan 67-69, NL-2132 JD, Hoofddorp, The Netherlands. • +31 (0) 23 568 13 00 • www.industrial.omron.eu

Authorized Distributor:

Automation Control Systems

- Machine Automation Controllers (MAC) • Programmable Controllers (PLC)
- Operator interfaces (HMI) • Distributed I/O • Software

Drives & Motion Controls

- Servo & AC Drives • Motion Controllers & Encoders

Temperature & Process Controllers

- Single and Multi-loop Controllers

Sensors & Vision

- Proximity Sensors • Photoelectric Sensors • Fiber-Optic Sensors
- Amplified Photomicrosensors • Measurement Sensors
- Ultrasonic Sensors • Vision Sensors

Industrial Components

- RFID/Code Readers • Relays • Pushbuttons & Indicators
- Limit and Basic Switches • Timers • Counters • Metering Devices
- Power Supplies

Safety

- Laser Scanners • Safety Mats • Edges and Bumpers • Programmable Safety Controllers • Light Curtains • Safety Relays • Safety Interlock Switches