

Mat Controller

MC3 Series

Installation and Operating Manual

Original Instructions



MC-3 Mat Controller

Table of Contents

Section 1— <i>Important safety message</i>	page 4
Section 2— <i>Introduction</i>	page 6
Section 3— <i>Description of Controls</i>	page 6
Section 4— <i>Operating Mode</i>	page 7
Section 5— <i>Installation</i>	page 8
Section 6— <i>Machine Control Connections</i>	page 11
Section 7— <i>Test Procedure</i>	page 15
Section 8— <i>Trouble-shooting Faults</i>	page 15
Section 9— <i>Specifications</i>	page 16
Section 10— <i>Warranty and Additional Information</i>	page 18
Section Appendix A — <i>Test Procedure</i>	page 20
Section Appendix B — <i>Declaration of Conformity Information</i>	page 21

1 IMPORTANT SAFETY MESSAGE

A presence sensing mat and controller are general purpose presence sensing devices designed to guard personnel working around moving machinery. The use of this type of guarding system is regulated by government safety agencies.

Whether a specific machine application and presence sensing mat and controller installation complies with government regulations depends upon several items, including: the proper application, installation, maintenance and operation of the presence sensing mat and controller. These items are the sole responsibility of the purchaser, installer and employer.

The employer is also responsible for the selection and training of the personnel necessary to properly install, operate and maintain the machine and its safeguarding systems. For example, the presence sensing mat and controller should be installed, checked out and maintained only by a *qualified* person, defined as “*a person who, by possession of a recognized degree in applicable field or certificate of professional standing, or who by extensive knowledge, training, and experience, has successfully demonstrated the ability to solve problems relating to the subject matter and work.*” (ASME B30.2-2001)

The machine operator must notify management if the machine, tooling or safety devices are not operating properly. Never use the machine if it or the safety equipment is not in proper working order.

The following additional requirements must be met before using a safety mat and controller system:

- The machine on which the presence sensing mat and controller are installed must be capable of stopping motion anywhere in its cycle or stroke. Never use a presence sensing mat and controller on a power press with a full-revolution clutch.
- Do not use a presence sensing mat and controller:
 - on any device with inconsistent stopping time or inadequate control devices or mechanisms.
 - where the environment, such as corrosive chemicals, may degrade the performance of the mat and/or controller.
 - to initiate machine motion.

- When a presence sensing mat and controller are used as a safety device, the employer has the responsibility to ensure that all applicable federal, state, and local requirements, rules, codes and regulations are satisfied.
- All safety related machine control circuit elements, including pneumatic, electric or hydraulic controls, must be control reliable as defined by ANSI B11.19-2003, 6.1 which states in part:
 - prevent initiation of hazardous machine motion (or situation) until the failure is corrected or until the control system is manually reset; or
 - initiate an immediate stop command and prevent re-initiation of hazardous machine motion (or situation) until the failure is corrected or until the control system is manually reset; or
 - prevent re-initiation of hazardous machine motion (or situation) at the next normal stop command until the failure is corrected or until the control system is manually reset.
- All other machinery or equipment must meet OSHA standard 1910.212 for general machine guarding plus any other applicable regulations, codes and standards.
- Additional guarding such as safety light curtains or mechanical guards may be required if the presence sensing mat and controller do not protect all areas of entry to the point of operation hazard.
- All brakes and stopping mechanisms must be inspected regularly to ensure proper working order. If the stopping mechanisms are not working properly, the machine may not stop safely even though the presence sensing mat and controller are functioning properly.
- The Omron STI Test Procedure must be performed at installation and after any maintenance, modification or adjustment is performed on the machine controls or on the presence sensing mat and controller. The Test Procedure is presented in this manual.
- Do not perform any test or repairs other than those outlined in this manual. All electrical wiring must be installed in accordance with local electrical codes and regulations.
- The user must follow all procedures in this manual for proper operation of the MC3 controller.

The enforcement of these requirements is beyond Omron STI's control. The employer has the sole responsibility to follow the preceding requirements and any procedures, conditions and requirements specific to your machinery.

2 INTRODUCTION

Presence sensing mats and the MC3 controller are used where perimeter access guarding is required, such as around robots, manufacturing work cells, food processing equipment and automated assembly equipment.

The MC3 controller is designed to meet the applicable sections of ANSI B11.19-2003, OSHA1910.212, EN1760-1:1997 and ISO13856-1:2001. CE standards are met only when used in conjunction with OMRON STI UM and UMQ series presence sensing safety mats.

The MC3 controller is designed to work in conjunction with a four-wire, normally open safety mat (such as the Omron STI UM and UMQ series safety mats).

3 DESCRIPTION OF CONTROLS

3.1. OUTPUT RELAYS

The safety-rated outputs of the MC3 controller are referred to as Output Signal Switching Devices. (OSSD). When the mat surface is activated by sufficient weight, the OSSD will respond by going to an OFF state. Two-normally open OSSD are provided across terminal 13/14 and 23/24. Two normally closed OSSD are provided across terminals 31/32 and 41/42.

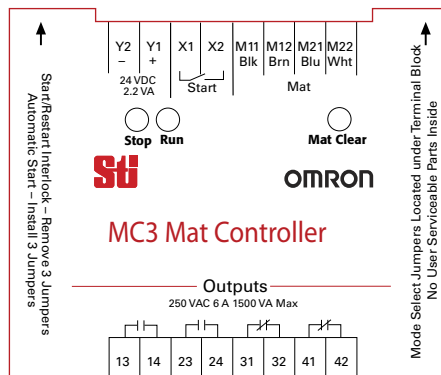

Figure 3-1 MC3 Mat Controller

3.2. INDICATORS

RUN: Will be lit when the OSSD relays are in the MACHINE RUN state.

STOP: Will be lit when the OSSD relays are in the MACHINE STOP state.

MAT CLEAR: A diagnostic indicator. Shows that the mat is properly wired, that it is clear, and that it is possible to energize the relays.

3.3. MAT INPUTS

Four terminal positions (M11-Blk, M12-Brn, M21-Blu, M22-Wh) are provided for input of a four-wire safety mat or a series of four-wire safety mats. See details in Section 5.2.—*Input Wiring.*

4 OPERATING MODE

4

4.1. AUTOMATIC RESTART

The MC3 controller will energize relays whenever the mat is clear, and de-energize whenever it has been stepped upon. During both power up and normal operation, an ON-delay of approximately 1/10 to 2/10 second is normal. The RUN indicator will follow the MAT CLEAR light.

4.2. START/RESTART INTERLOCK

The MC3 controller will interlock in de-energized state both upon application of power and also whenever the mat is stepped upon. Requires a manual reset operation to cause the system to energize relays. The MAT CLEAR light will indicate that it is possible to activate the start switch and enter into the MACHINE RUN state. The controller attempts to enter the RUN STATE upon the release of the start switch. Press and hold the start switch for more than 0.15 seconds. The safety mat area must be clear at the time the start switch is pressed and released.

5 INSTALLATION

- ▲ WARNING!** *Read this manual completely before installing the MC3 controller. The MC3 controller should only be installed, checked out, tested and maintained by a qualified person (as described in the Important Safety Message at the beginning of this manual). It is important that the user be familiar with the installation requirements, safe mounting distance, controls and features of the MC3 controller before using the guarding system.*

5.1. MOUNTING

5.1.1 MODE SELECT

The installer must select whether the MC3 controller will operate in AUTOMATIC START or START/RESTART INTERLOCK mode. To make the selection, remove the terminal block on the input side of the controller box. Behind this terminal block are three yellow jumpers.

With all three jumpers installed, the controller is configured for AUTOMATIC START operation. This is the factory setting.

To configure for START/RESTART INTERLOCK operation, all three jumpers must be removed.

- ▲ WARNING!** *Perimeter Guarding Special Requirements: Perimeter guarding refers to installations where the presence sensing mats are positioned around the outside perimeter of the machine, robot or area to be guarded. This could leave sufficient space for an operator to stand between the mats and the machine.*

For perimeter guarding installations, the guarded machine or robot must be wired such that any interruption of the sensing area will cause an immediate stop of the hazardous motion. The machine or robot must only be restarted by actuation of a start switch. This start switch must be located outside the area of hazardous motion and positioned such that the hazardous area may be observed by the start switch operator.

Unexpected or automatic restart of the machine or robot may cause severe injury or death to the operator or other personnel.

Always contact the machine manufacturer for advice and assistance on the proper connection of any safety device.

5.1.2 ENCLOSURE

The MC3 controller is designed to be installed inside a machine control cabinet which has an environmental rating of at least IP54.

5.2. INPUT WIRING

5.2.1 POWER

A 24VDC power source is required. Connect PLUS to terminal block Y1 position and MINUS (0, Return) to terminal block Y2 position. (Note: see separate discussion of “earth”)

5.2.2 START

Used only in START/RESTART INTERLOCK mode. If AUTOMATIC START mode is used, no connection is required. If required, customer-supplied remote start switch with a single set of normally open contacts is used.

Two optional wiring configurations are acceptable:

- Connect the remote start switch between terminals X1 and X2.
- Connect one terminal of the remote start switch to +24VDC (must share a common return with MC3 power supply), and the second terminal to X2.

5.2.3 SAFETY MAT

An Omron STI 4-wire mat is expected. For an Omron STI Universal safety mat the blue and black conductors are connected to the bottom electrode plate. The brown and white conductors are connected to the top electrode plate. For a single mat installation, black is connected to M11 and blue to M21. The brown conductor is connected to M12 and white conductor is connected to M22.

Multiple mats must be connected to the controller in series. To wire an STI UM series multiple mat system in series, follow the wiring as shown in the drawing below:

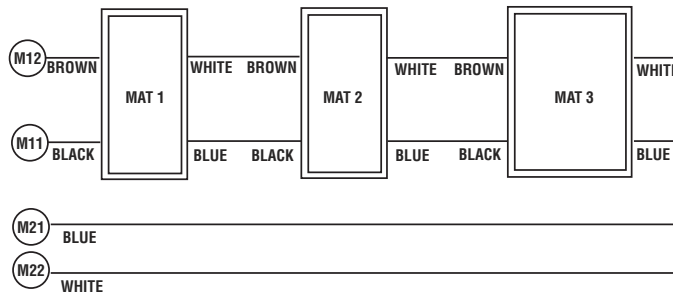

Figure 5-1 Hookup Drawing

- ▲ WARNING!** *Connecting mats in parallel will appear to work, but it is an UNSAFE installation. In this configuration, it is possible for one or more mats to be disconnected or have an open wire and the controller will not detect that these mats are non-functioning.*

5.2.4 EARTH CONSIDERATIONS

Normally, earthing of the house system is not a consideration. Presence sensing mats are sealed - any wiring to them should not be in contact with earth. Likewise, the mat controller operates between +24VDC and it's return, so the selection of an earth scheme is not significant.

However, there are abnormal conditions that could cause current flow due to house earth. This is related to the fact that mats lie on the floor, and are typically in close proximity to true "earth". Under certain conditions (e.g. wetting of the mat cable connectors), it is possible that one of the plates of the mat might become referenced to earth.

Note: *If the entire connector becomes immersed, this is the equivalent of the mat being shorted, and the system will simply indicate so, i.e. the mat clear indicator will not be able to light.*

One of the mat plates is electrically connected through the mat controller to the 24VDC return. (minus, Y2). If the plus side of the 24VDC power supply is earthed, and the minus side of the mat is also earthed, ground current will attempt to flow through the mat controller. This will cause the primary power fuse to blow. However, the fuse is a self-mending type, and will continue to re-make and blow again.

5.3. OUTPUT WIRING

Two safety outputs must be connected to, and operate, the two MPCE of the guarded machine. One to each. The product offers two normally closed and two normally open FSD (final switching device) outputs for this purpose. Customer shall wire by normal methods. External over-current protection must be provided by the user.

The remaining two connections may be used for indicator/communications purposes as desired.

6 MACHINE CONTROL CONNECTIONS

6.1. TWO NORMALLY OPEN PREFERRED CONNECTION METHOD

The following connection scheme uses both of the normally open output relay contacts to control the machine. This is the Omron STI recommended wiring method.

In the machine control circuit, locate the two machine primary control elements (MPCE1 & MPCE2). These are defined as *“The electrically powered element that directly controls the normal operation of a machine in such a way that it is the last element (in time) to function when machine operation is to be initiated or arrested.”* IEC 61496-1

The method to arrest hazardous machine motion will vary depending on the type of machine. Control methods include hydraulic, pneumatic, clutch and mechanical braking systems. For example, an MPCE may consist of relays, contactors, solenoids or electromechanical valves. If relays, the MPCE must use force-guided contact type relays.

**TWO NORMALLY OPEN
PREFERRED CONNECTION DIAGRAM**

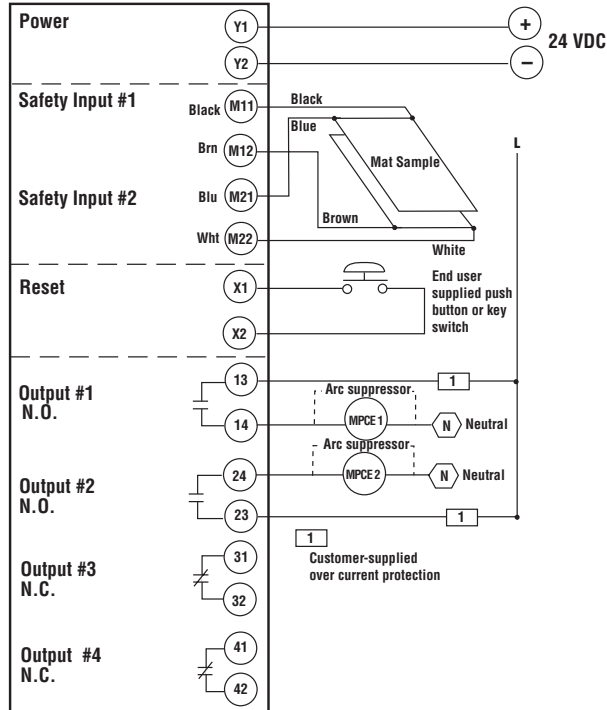

Figure 6-1 Two Normally Open Preferred Connection

6.2. SUGGESTED PLC CONNECTION

The wiring from the MC3 controller to the machine control must be control reliable as explained in ANSI B11.19-2003 section 6.1 or OSHA 1910.217(b)(13). Normally, PLCs are not designed to be control reliable and thus safety devices, such as safety mat systems, must not depend on a PLC to stop a guarded machine.

Figure 6-2 shows a connection diagram which provides for an extra set of contacts on each MPCE to be used as a signal input to a PLC. Note that in this diagram, the PLC is not wired directly to the MC3 controller and thus removes the PLC from the safety mat controller stop signal circuit.

Always contact the manufacturers of the PLC and the guarded machine before using a PLC in conjunction with an operator safety control.

The PLC control system design, wiring, installation and programming are the sole responsibility of the employer.

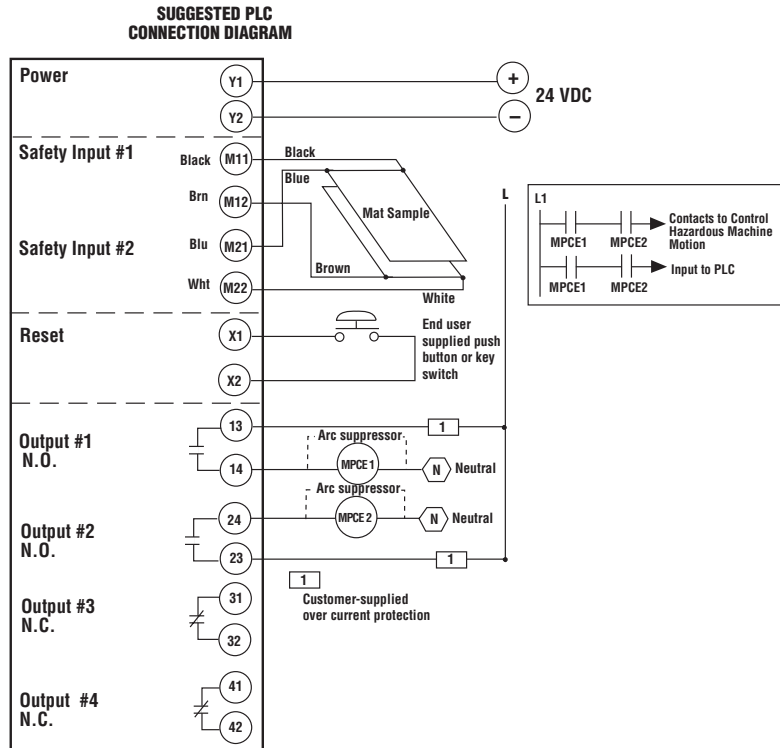

Figure 6-2 Suggested PLC Connection

- ⚠ WARNING!** To prevent severe injury to the operator or other personnel, **DO NOT** operate this presence sensing safety device (mat and controller system) unless it is properly installed, tested and inspected in accordance with all OSHA, ANSI, government, industry and company safety regulations. The guarded machine must be capable of stopping motion anywhere in its stroke or cycle. Do not use this safety device on a full revolution clutch machine.

7 TEST PROCEDURE

7.1. PERFORMING TEST PROCEDURE

The test procedure given in Appendix A must be performed by a qualified person at installation and after any maintenance, adjustment, or modification to the presence sensing mats, the MC3 controller or the machine and machine control circuitry. Testing ensures that the mats, MC3 controller, machine and machine control circuitry work properly to stop the machine. Failure to test properly could result in serious injury to personnel.

8 TROUBLE-SHOOTING FAULTS

8

Symptom

No indicators lit.

Possible Solutions

No power to the controller. Check 24VDC power supply and its connections to Y1/Y2. Also see earth discussion in Section 5.2.4 “Earth Considerations”.

Symptom

MAT CLEAR indicator cannot be made to light.

Possible Solutions

1. Mat wired improperly. Check connections.
2. Mat wire broken. Replace mat.
3. Mat is shorted. Is there something on the sensing area? Is the surface deformed?

Symptom

Cannot start in START/RESTART INTERLOCK mode.

Possible Solutions

1. Check wiring and operation of START switch. Is 24VDC being delivered when START is depressed and not delivered when it is released?
2. This line is internally fused with a self-mending fuse. Does it blow and reset repeatedly? If so, see earth discussion Section 5.2.4 “Earth Considerations”.

Symptom

All other conditions

Possible Solutions

Controller is defective. Replace. Call Omron STI for details.

9 SPECIFICATIONS

9

9.1. MAT CONTROLLER—MC3

9.1.1 GENERAL SPECIFICATIONS

Category: Category 3 safety device

Operating Modes: Automatic Start or Start/Restart Interlock

9.1.2 ELECTRICAL

Power Input: 24 VDC ($\pm 15\%$, < 3W.)

Safety Input: Connections for a four-wire mat system

Indicators: Green=Mat Clear; Green=Run; Red=Stop

Reset Function: User-supplied pushbutton or key switch

Safety Outputs: 2 NO and 2 NC outputs. 230VAC, 6A, 1500VA Maximum (non-fused)

Response time: < 0.030 seconds (STI UM series safety mat and controller combined)

9.1.3 CONSTRUCTION

Case Material: Polycarbonate

IP Rating: IP20

Mounting Type: 35mm DIN rail or screw mount to panel

Shipping Weight: 0.8 pounds (0.32 kg)

9.1.4 ENVIRONMENTAL

Temperature: 0° to +55°C (32° to 131°F)

Shock & Vibration: Per IEC 68-2-6, 0.15mm displacement, 10 to 55 Hz

Relative Humidity: 95%

9.1.5 STANDARDS CONFORMITY

Designed in Accordance with: EN1760-1:1997 + A1:2009, EN 62061:2005, EN ISO 13849-1:2008, IEC 61508, parts 1-7:1998-2000, EN 50178:1997, EN 60204-1:2006, Machinery Directive 2006/42/EC, ANSI/RIA 15.06-1999, ANSI B11.19-2003, OSHA 1910.212 & 1910.217(b)

9.1.6 Approvals

CE, TUV, CSA

9.1.7 Conformities

PSPD Type 3 (EN 1760-1:2997 + A1:2009),
Category 3 / PL d (EN ISO 13849-1),
SIL 2 / SIL2 CL2 (IEC 61508 / EN 62061).

9.1.8 Safety Related Parameters

PFH = 3.97 E-08 1/h
Proof Test Interval = 20 years
MTTFd = 94 years

9.2. SYSTEM DRAWINGS

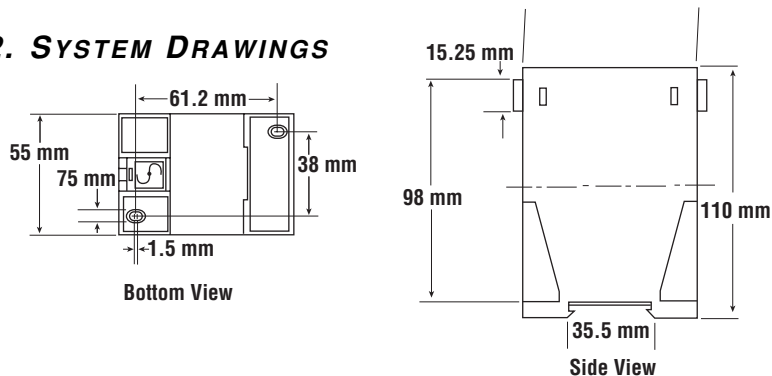

Figure 9-1 Mat Controller MC3 Dimensional Drawing

10 WARRANTY AND ADDITIONAL INFORMATION

10

10.1. OMRON STI WARRANTY

Omron STI warrants its products to be free from defects of material and workmanship and will, without charge, replace or repair any equipment found defective upon inspection at its factory, provided the equipment has been returned, transportation prepaid, within one year from the date of installation and not to exceed 18 months from date of factory shipment.

The foregoing warranty is in lieu of and excludes all other warranties not expressly set forth herein, whether expressed or implied by operation of law or otherwise including but not limited to any implied warranties of merchantability or fitness for a particular purpose. No representation or warranty, express or implied, made by any sales representative, distributor, or other agent or representative of Omron STI which is not specifically set forth herein shall be binding upon Omron STI. Omron STI shall not be liable for any incidental or consequential damages, losses or expenses directly or indirectly arising from the sale, handling, improper application or use of the goods or from any other cause relating thereto and Omron STI's liability hereunder, in any case, is expressly limited to repair or replacement (at Omron STI's option) of goods.

Warranty is specifically at the factory or an Omron STI authorized service location. Any on site service will be provided at the sole expense of the Purchaser at standard field service rates.

All associated equipment must be protected by properly rated electronic/electrical protection devices. Omron STI shall not be liable for any damage due to improper engineering or installation by the purchaser or third parties. Proper installation, operation and maintenance of the product becomes the responsibility of the user upon receipt of the product.

10.1.1 PATENTS

Elements of the electronics and optics essential to meet the specifications and performance standards of Omron STI controls are covered by one or more of the



following U.S. Patent Numbers: 3,774,039; 3,867,628; 3,967,111; 3,996,476; 4,007,387; 4,101,784; 5,015,840; Design 255,031, and other patents pending.

10.1.2 REPAIRS

Omron STI offers product repair service at our factory. If you need repairs made to any Omron STI product contact our Customer Service Department.

10.1.3 RETURNS

Whenever you return a product to Omron STI (even if the product is in warranty) please contact our Customer Service Department and request a Returned Goods Authorization number (RGA).

10.1.4 DOCUMENTATION CRITERIA

This publication has been carefully checked for accuracy and is believed to be fully consistent with the products it describes. However, Omron STI does not assume liability for the contents of this publication; the examples used within or the use of any product described herein. Omron STI reserves the right to make changes to products and/or documentation without further notification.

APPENDIX A — TEST PROCEDURE

A.1. TEST PROCEDURE LOG

The following test procedure must be performed by qualified personnel at installation and after any maintenance, adjustment or modification to the presence sensing mats, the MC3 controller or the machine and machine control circuitry. Testing ensures that the presense sensing mats, MC3 controller, machine and machine controll circuitry work properly to stop the machine. Failure to test properly could result in serious injury to personnel. Familiarity with this installation and operating manual is required before proceeding.

Item	Condition	Comments
1. With the machine power off, the MC3 controller power on and no pressure on the mat sensing area, verify that either a) a green RUN indicator is on, if set for AUTOMATIC START mode, or b) the red STOP indicator is on if set for START/RESTART INTERLOCK mode. In both cases the green MAT CLEAR indicator should be on.	<input type="checkbox"/> Pass <input type="checkbox"/> Fail	
2. If installed, press the START button to restart the controller from an interlocked state. The green RUN indicator should now be on and the output relays should be energized. The mat clear indicator should be on.	<input type="checkbox"/> Pass <input type="checkbox"/> Fail	
3. Step on the mat sensing area to activate the MC3 controller. The green RUN indicator should go off and, in all operating modes, the red STOP indicator should go on and the green MAT CLEAR indicator should go off. Repeat steps 2 and 3 for each mat in the sensing area.	<input type="checkbox"/> Pass <input type="checkbox"/> Fail	
4. With the MC3 controller in the RUN condition, start the machine to be guarded. Step on each mat in the sensing area and verify that the machine stops immediately and that the red STOP indicator illuminates.	<input type="checkbox"/> Pass <input type="checkbox"/> Fail	
5. If the presence sensing mats, MC3 controller or the machine fail any of these tests, DO NOT run the machine. Immediately tag or lockout the machine to prevent its use and notify the supervisor.	<input type="checkbox"/> Pass <input type="checkbox"/> Fail	

WARNING! To prevent severe injury to the operator or other personnel, DO NOT operate this presence sensing safety device unless it is properly installed, tested and inspected in accordance with all applicable ANSI, OSHA, government, industry and company safety regulations. The guarded machine must be capable of stopping motion anywhere in its cycle or stroke. Do not use this safety device on a full revolution clutch machine.



APPENDIX B — DECLARATION OF CONFORMITY INFORMATION

OMRON SCIENTIFIC TECHNOLOGIES INCORPORATED

EC Declaration of Conformity

OMRON Scientific Technologies Incorporated (at 6550 Dumbarton Circle, Fremont, CA 94555-3605, U.S.A.), hereby declares that the following series manufactured products listed below conform with the relevant Essential Health and Safety Requirements (EHSRs) of the European **Machinery Directive** (2006/42/EC), the relevant requirements of the **Low Voltage Directive** (2006/95/EC), with the essential protection requirements of the **Electromagnetic Compatibility (EMC) Directive** (2004/108/EC), and with the **RoHS Directive** (2002/95/EC) - the restriction of the use of certain hazardous substances in electrical and electronic equipment.

Universal Safety Mat Systems UM, UMM, UMQ & UMMQ Series with Safety Mat Controller MC3,
(Pressure-sensitive protective device – consisting of pressure-sensitive mats and controllers. Not suitable for the detection of children)

The **Universal Safety Mat UM Series with MC Series Safety Mat Controllers** products have been type-examined per

EC Type Examination Certificate, Registration No: 01/205/0676/09

issued by notified body **TUV Rheinland Industrie Service GmbH, Certification Body for Machinery (NB No. 0035).**

The following transposed harmonized European and IEC Standards were used to form the basis for the requirements and tests:

EN 1760-1:1997: + A1:2009 - Safety of Machinery – Pressure-sensitive protective devices

Part 1: General principles for the design and testing of pressure-sensitive mats and pressure-sensitive floors.

EN 62061:2005 – Safety of machinery. Functional safety of safety-related electrical, electronic and programmable electronic control systems.

EN ISO 13849-1:2008 – Safety of machinery. Safety-related parts of control systems. General principles for design

IEC 61508, parts 1 – 7:1998 – 2000 - Functional Safety Of Electrical/Electronic/Programmable electronic Safety-Related Systems.

IEC 50178:1997 - Electronic equipment for use in power installations

EN 60204-1:2006: Safety of machinery – Electrical equipment of machines, Part 1: General requirements.

OMRON Europe B.V.
Wegalaam 67 - 69
2132 JD Hoofddorp
Netherlands
Tel: +31 (0)23 568 13 00
Tel: +31 (0)23 568 13 88

Terms and Conditions of Sale

1. **Offer; Acceptance.** These terms and conditions (these "Terms") are deemed part of all quotes, agreements, purchase orders, acknowledgments, price lists, catalogs, manuals, brochures and other documents, whether electronic or in writing, relating to the sale of products or services (collectively, the "Products") by Omron Electronics LLC and its subsidiary companies ("Omron"). Omron objects to any terms or conditions proposed in Buyer's purchase order or other documents which are inconsistent with, or in addition to, these Terms.
2. **Prices; Payment Terms.** All prices stated are current, subject to change without notice by Omron. Omron reserves the right to increase or decrease prices on any unshipped portions of outstanding orders. Payments for Products are due net 30 days unless otherwise stated in the invoice.
3. **Discounts.** Cash discounts, if any, will apply only on the net amount of invoices sent to Buyer after deducting transportation charges, taxes and duties, and will be allowed only if (i) the invoice is paid according to Omron's payment terms and (ii) Buyer has no past due amounts.
4. **Interest.** Omron, at its option, may charge Buyer 1-1/2% interest per month or the maximum legal rate, whichever is less, on any balance not paid within the stated terms.
5. **Orders.** Omron will accept no order less than \$200 net billing.
6. **Governmental Approvals.** Buyer shall be responsible for, and shall bear all costs involved in, obtaining any government approvals required for the importation or sale of the Products.
7. **Taxes.** All taxes, duties and other governmental charges (other than general real property and income taxes), including any interest or penalties thereon, imposed directly or indirectly on Omron or required to be collected directly or indirectly by Omron for the manufacture, production, sale, delivery, importation, consumption or use of the Products sold hereunder (including customs duties and sales, excise, use, turnover and license taxes) shall be charged to and remitted by Buyer to Omron.
8. **Financial.** If the financial position of Buyer at any time becomes unsatisfactory to Omron, Omron reserves the right to stop shipments or require satisfactory security or payment in advance. If Buyer fails to make payment or otherwise comply with these Terms or any related agreement, Omron may (without liability and in addition to other remedies) cancel any unshipped portion of Products sold hereunder and stop any Products in transit until Buyer pays all amounts, including amounts payable hereunder, whether or not then due, which are owing to it by Buyer. Buyer shall in any event remain liable for all unpaid accounts.
9. **Cancellation; Etc.** Orders are not subject to rescheduling or cancellation unless Buyer indemnifies Omron against all related costs or expenses.
10. **Force Majeure.** Omron shall not be liable for any delay or failure in delivery resulting from causes beyond its control, including earthquakes, fires, floods, strikes or other labor disputes, shortage of labor or materials, accidents to machinery, acts of sabotage, riots, delay in or lack of transportation or the requirements of any government authority.
11. **Shipping; Delivery.** Unless otherwise expressly agreed in writing by Omron:
 - a. Shipments shall be by a carrier selected by Omron; Omron will not drop ship except in "break down" situations.
 - b. Such carrier shall act as the agent of Buyer and delivery to such carrier shall constitute delivery to Buyer;
 - c. All sales and shipments of Products shall be FOB shipping point (unless otherwise stated in writing by Omron), at which point title and risk of loss shall pass from Omron to Buyer; provided that Omron shall retain a security interest in the Products until the full purchase price is paid;
 - d. Delivery and shipping dates are estimates only; and
 - e. Omron will package Products as it deems proper for protection against normal handling and extra charges apply to special conditions.
12. **Claims.** Any claim by Buyer against Omron for shortage or damage to the Products occurring before delivery to the carrier must be presented in writing to Omron within 30 days of receipt of shipment and include the original transportation bill signed by the carrier noting that the carrier received the Products from Omron in the condition claimed.
13. **Warranties.** (a) **Exclusive Warranty.** Omron's exclusive warranty is that the Products will be free from defects in materials and workmanship for a period of twelve months from the date of sale by Omron (or such other period expressed in writing by Omron). Omron disclaims all other warranties, express or implied. (b) **Limitations.** OMRON MAKES NO WARRANTY OR REPRESENTATION, EXPRESS OR IMPLIED, ABOUT NON-INFRINGEMENT, MERCHANTABILITY OR FITNESS FOR A PARTICULAR PURPOSE OF THE PRODUCTS. BUYER ACKNOWLEDGES THAT IT ALONE HAS DETERMINED THAT THE PRODUCTS WILL SUITABLY MEET THE REQUIREMENTS OF THEIR INTENDED USE. Omron further disclaims all warranties and responsibility of any type for claims or expenses based on infringement by the Products or otherwise of any intellectual property right. (c) **Buyer Remedy.** Omron's sole obligation hereunder shall be, at Omron's election, to (i) replace (in the form originally shipped with Buyer responsible for labor charges for removal or replacement thereof) the non-complying Product, (ii) repair the non-complying Product, or (iii) repay or credit Buyer an amount equal to the purchase price of the non-complying Product; provided that in no event shall Omron be responsible for warranty, repair, indemnity or any other claims or expenses regarding the Products unless Omron's analysis confirms that the Products were properly handled, stored, installed and maintained and not subject to contamination, abuse, misuse or inappropriate modification. Return of any Products by Buyer must be approved in writing by Omron before shipment. Omron Companies shall not be liable for the suitability or unsuitability or the results from the use of Products in combination with any electrical or electronic components, circuits, system assemblies or any other materials or substances or environments. Any advice, recommendations or information given orally or in writing, are not to be construed as an amendment or addition to the above warranty. See <http://www.omron247.com> or contact your Omron representative for published information.
14. **Limitation on Liability; Etc.** OMRON COMPANIES SHALL NOT BE LIABLE FOR SPECIAL, INDIRECT, INCIDENTAL, OR CONSEQUENTIAL DAMAGES, LOSS OF PROFITS OR PRODUCTION OR COMMERCIAL LOSS IN ANY WAY CONNECTED WITH THE PRODUCTS, WHETHER SUCH CLAIM IS BASED IN CONTRACT, WARRANTY, NEGLIGENCE OR STRICT LIABILITY. Further, in no event shall liability of Omron Companies exceed the individual price of the Product on which liability is asserted.
15. **Indemnities.** Buyer shall indemnify and hold harmless Omron Companies and their employees from and against all liabilities, losses, claims, costs and expenses (including attorney's fees and expenses) related to any claim, investigation, litigation or proceeding (whether or not Omron is a party) which arises or is alleged to arise from Buyer's acts or omissions under these Terms or in any way with respect to the Products. Without limiting the foregoing, Buyer (at its own expense) shall indemnify and hold harmless Omron and defend or settle any action brought against such Companies to the extent based on a claim that any Product made to Buyer specifications infringed intellectual property rights of another party.
16. **Property; Confidentiality.** Any intellectual property in the Products is the exclusive property of Omron Companies and Buyer shall not attempt to duplicate it in any way without the written permission of Omron. Notwithstanding any charges to Buyer for engineering or tooling, all engineering and tooling shall remain the exclusive property of Omron. All information and materials supplied by Omron to Buyer relating to the Products are confidential and proprietary, and Buyer shall limit distribution thereof to its trusted employees and strictly prevent disclosure to any third party.
17. **Export Controls.** Buyer shall comply with all applicable laws, regulations and licenses regarding (i) export of products or information; (iii) sale of products to "forbidden" or other proscribed persons; and (ii) disclosure to non-citizens of regulated technology or information.
18. **Miscellaneous.** (a) **Waiver.** No failure or delay by Omron in exercising any right and no course of dealing between Buyer and Omron shall operate as a waiver of rights by Omron. (b) **Assignment.** Buyer may not assign its rights hereunder without Omron's written consent. (c) **Law.** These Terms are governed by the law of the jurisdiction of the home office of the Omron company from which Buyer is purchasing the Products (without regard to conflict of law principles). (d) **Amendment.** These Terms constitute the entire agreement between Buyer and Omron relating to the Products, and no provision may be changed or waived unless in writing signed by the parties. (e) **Severability.** If any provision hereof is rendered ineffective or invalid, such provision shall not invalidate any other provision. (f) **Setoff.** Buyer shall have no right to set off any amounts against the amount owing in respect of this invoice. (g) **Definitions.** As used herein, "including" means "including without limitation"; and "Omron Companies" (or similar words) mean Omron Corporation and any direct or indirect subsidiary or affiliate thereof.

Certain Precautions on Specifications and Use

1. **Suitability of Use.** Omron Companies shall not be responsible for conformity with any standards, codes or regulations which apply to the combination of the Product in the Buyer's application or use of the Product. At Buyer's request, Omron will provide applicable third party certification documents identifying ratings and limitations of use which apply to the Product. This information by itself is not sufficient for a complete determination of the suitability of the Product in combination with the end product, machine, system, or other application or use. Buyer shall be solely responsible for determining appropriateness of the particular Product with respect to Buyer's application, product or system. Buyer shall take application responsibility in all cases but the following is a non-exhaustive list of applications for which particular attention must be given:
 - (i) Outdoor use, uses involving potential chemical contamination or electrical interference, or conditions or uses not described in this document.
 - (ii) Use in consumer products or any use in significant quantities.
 - (iii) Energy control systems, combustion systems, railroad systems, aviation systems, medical equipment, amusement machines, vehicles, safety equipment, and installations subject to separate industry or government regulations.
 - (iv) Systems, machines and equipment that could present a risk to life or property. Please know and observe all prohibitions of use applicable to this Product.

NEVER USE THE PRODUCT FOR AN APPLICATION INVOLVING SERIOUS RISK TO LIFE OR PROPERTY OR IN LARGE QUANTITIES WITHOUT ENSURING THAT THE SYSTEM AS A WHOLE HAS BEEN DESIGNED TO ADDRESS THE RISKS, AND THAT THE OMRON'S PRODUCT IS PROPERLY RATED AND INSTALLED FOR THE INTENDED USE WITHIN THE OVERALL EQUIPMENT OR SYSTEM.
2. **Programmable Products.** Omron Companies shall not be responsible for the user's programming of a programmable Product, or any consequence thereof.
3. **Performance Data.** Data presented in Omron Company websites, catalogs and other materials is provided as a guide for the user in determining suitability and does not constitute a warranty. It may represent the result of Omron's test conditions, and the user must correlate it to actual application requirements. Actual performance is subject to the Omron's Warranty and Limitations of Liability.
4. **Change in Specifications.** Product specifications and accessories may be changed at any time based on improvements and other reasons. It is our practice to change part numbers when published ratings or features are changed, or when significant construction changes are made. However, some specifications of the Product may be changed without any notice. When in doubt, special part numbers may be assigned to fix or establish key specifications for your application. Please consult with your Omron's representative at any time to confirm actual specifications of purchased Product.
5. **Errors and Omissions.** Information presented by Omron Companies has been checked and is believed to be accurate; however, no responsibility is assumed for clerical, typographical or proofreading errors or omissions.

OMRON AUTOMATION AND SAFETY • THE AMERICAS HEADQUARTERS • Chicago, IL USA • 847.843.7900 • 800.556.6766 • www.omron247.com

OMRON CANADA, INC. • HEAD OFFICE

Toronto, ON, Canada • 416.286.6465 • 866.986.6766 • www.omron247.com

OMRON ELECTRONICS DE MEXICO • HEAD OFFICE

México DF • 52.55.59.01.43.00 • 01-800-226-6766 • mela@omron.com

OMRON ELECTRONICS DE MEXICO • SALES OFFICE

Apodaca, N.L. • 52.81.11.56.99.20 • 01-800-226-6766 • mela@omron.com

OMRON ELETRÔNICA DO BRASIL LTDA • HEAD OFFICE

São Paulo, SP, Brasil • 55.11.2101.6300 • www.omron.com.br

OMRON ARGENTINA • SALES OFFICE

Cono Sur • 54.11.4783.5300

OMRON CHILE • SALES OFFICE

Santiago • 56.9.9917.3920

OTHER OMRON LATIN AMERICA SALES

54.11.4783.5300

OMRON EUROPE B.V. • Wegalaan 67-69, NL-2132 JD, Hoofddorp, The Netherlands. • +31 (0) 23 568 13 00 • www.industrial.omron.eu

Authorized Distributor:

Automation Control Systems

- Machine Automation Controllers (MAC) • Programmable Controllers (PLC)
- Operator interfaces (HMI) • Distributed I/O • Software

Drives & Motion Controls

- Servo & AC Drives • Motion Controllers & Encoders

Temperature & Process Controllers

- Single and Multi-loop Controllers

Sensors & Vision

- Proximity Sensors • Photoelectric Sensors • Fiber-Optic Sensors
- Amplified Photomicrosensors • Measurement Sensors
- Ultrasonic Sensors • Vision Sensors

Industrial Components

- RFID/Code Readers • Relays • Pushbuttons & Indicators
- Limit and Basic Switches • Timers • Counters • Metering Devices
- Power Supplies

Safety

- Laser Scanners • Safety Mats • Edges and Bumpers • Programmable Safety Controllers • Light Curtains • Safety Relays • Safety Interlock Switches