

Fluoroplastic Housing Sensor Performs Accurately Under Harsh Environmental Conditions

- Full body resin housing and nuts resist weld spatter
- Rugged watertight fluoroplastic housing provides chemical resistance and withstands washdowns
- Conforms to NEMA 1, 4X, 6, 12, 13 and IP67
- Oil-resistant cable



Ordering Information

■ SENSORS

Sensing head		M12	M18	M30
Type		Shielded		
Nominal sensing distance		2 mm (0.08 in.)	5 mm (0.20 in.)	10 mm (0.39 in.)
AC 2-wire switching type	NO	—	E2FQ-X5Y1	E2FQ-X10Y1
DC 3-wire switching type	PNP (NO)	E2FQ-X2F1	E2FQ-X5F1	E2FQ-X10F1
	NPN (NO)	E2FQ-X2E1	E2FQ-X5E1	E2FQ-X10E1
DC 2-wire switching type	NO	E2FQ-X2D1	E2FQ-X5D1	E2FQ-X10D1

■ REPLACEMENT PARTS

Description	Part number	
Fluoroplastic-coated nuts and nickel-plated brass washers (2 each)	For M12 sensors	M12 THWS
	For M18 sensors	M18 THWS
	For M30 sensors	M30 THWS

Specifications

■ 3-WIRE DC SENSORS

Part number	3-wire	E2FQ-X2E1, E2FQ-X2F1	E2FQ-X5E1, E2FQ-X5F1	E2FQ-X10E1, E2FQ-X10F1
	2-wire	E2FQ0X2D1	E2FQ-X5D1	E2FQ-X10D1
Body	Size	M12	M18	M30
	Type	Shielded		
Supply voltage		10 to 30 VDC		
Current consumption	3-wire sensors	17 mA max.		
	2-wire sensors	0.8 mA max.		
Detectable object type		Metal objects		
Effective maximum detecting distance (with standard target)		2 mm (0.08 in.) ±10%	5 mm (0.20 in.) ±10%	10 mm (0.39 in.) ±10%
Usable detecting range (with standard target)		0 to 1.6 mm (0 to 0.06 in.)	0 to 4 mm (0 to 0.16 in.)	0 to 8 mm (0 to 0.31 in.)
Standard target size (mild steel, L x W x H)		12 x 12 x 1 mm (0.47 x 0.47 x 0.04 in.)	18 x 18 x 1 mm (0.71 x 0.71 x 0.04 in.)	30 x 30 x 1 mm (1.18 x 1.18 x 0.04 in.)
Differential travel		10% max. of effective detecting distance		
Control output	DC solid-state	Type	E2FQ-X□E1 (3-wire, NPN-NO with pull-up resistor) E2FQ-X□F1 (3-wire, PNP-NO with pull down resistor) E2FQ-X□D1 (2-wire, transistor)	
		Max. load	200 mA (3-wire sensors) 100 mA (2-wire sensors)	
		Max. on-state voltage drop	2 VDC (3-wire sensors) 4 VDC (2-wire sensors)	
OFF-state leakage current		Refer to "Engineering Data"		
Response frequency	3-wire	1.5 kHz	600 Hz	400 Hz
	2-wire	800 Hz	500 Hz	300 Hz
Circuit protection	Output short-circuit	Provided (3-wire models only); automatic resetting type		
	DC power supply reverse polarity	Provided, all models		
	Weld field immunity	—		
	RFI immunity	—		
Indicators		Target present (red LED)		
Materials	Housing	Fluoroplastic resin		
	Sensing face	Fluoroplastic resin		
	Cable sheath	PVC		
Mounting		Two fluoroplastic-coated M12 nuts included.	Two fluoroplastic-coated M18 nuts included.	Two fluoroplastic-coated M30 nuts included.
Connections	Prewired	Cable, 2 m (6.56 ft.) length		
Weight with cable		Approx. 50 g (1.8 oz.)	Approx. 130 g (4.6 oz.)	Approx. 170 g (6.0 oz.)
Enclosure ratings	NEMA	1, 4X, 6, 12, 13		
	IEC 144	IP67		
Approvals	UL	—		
	CSA	—		
Ambient operating temperature		-25° to 70°C (-13° to 158°F)		
Vibration		10 to 55 Hz, 1.5 mm (0.06 in.) double amplitude		
Shock		Approx. 100 Gs		

■ 2-WIRE AC SENSORS

Part number		E2FQ-X5Y1	E2FQ-X10Y1
Body	Size	M18	M30
	Type	Shielded	
Supply voltage		20 to 264 VAC, 50/60 Hz	
Current consumption		1.7 mA max. (at 200 VAC)	
Detectable object type		Metal objects	
Effective maximum detecting distance (with standard target)		5 mm (0.20 in.) ±10%	10 mm (0.39 in.) ±10%
Usable detecting range (with standard target)		0 to 4 mm (0 to 0.16 in.)	0 to 8 mm (0 to 0.31 in.)
Standard target size (mild steel, L x W x H)		18 x 18 x 1 mm (0.71 x 0.71 x 0.04 in.)	30 x 30 x 1 mm (1.18 x 1.18 x 0.04 in.)
Differential travel		10% max. of effective detecting distance	
Control output	AC solid-state	Type	E2FQ-X□□Y1 (SCR-NO)
		Max. load	300 mA
		Min. load	5 mA
		Max. off-state leakage current	1.7 mA at 200 VAC
		Max. on-state voltage drop	See "Residual Load Voltage Characteristics" graph in Engineering Data
OFF-state leakage current		Refer to "Engineering Data"	
Response frequency		25 Hz	
Circuit protection	Output short-circuit	—	
	Weld field immunity	—	
	RFI immunity	—	
Indicators		Output operation (red LED)	
Materials	Housing	Fluoroplastic resin	
	Sensing face	Fluoroplastic resin	
	Cable sheath	PVC	
Mounting		Two fluoroplastic M18 nuts included.	Two fluoroplastic M30 nuts included.
Connections	Prewired	2-conductor cable, 2 m (6.56 ft.) length	
Weight with cable		Approx. 130 g (4.6 oz.)	Approx. 170 g (6.0 oz.)
Enclosure ratings	UL	—	
	NEMA	1, 4X, 6, 12, 13	
	IEC 144	IP67	
Ambient operating temperature		-25° to 70°C (-13° to 158°F)	
Vibration		10 to 55 Hz, 1.5 mm (0.06 in.) double amplitude	
Shock		Approx. 100 Gs	

Operation

■ OUTPUT CIRCUIT DIAGRAM

DC Switching Type

NPN Output
(E2FQ-X□E1)

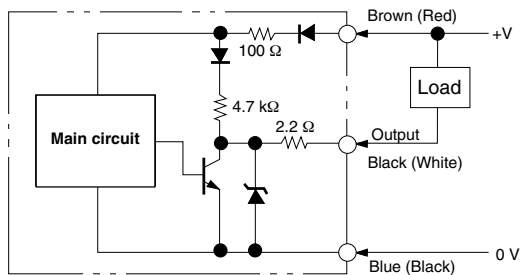

PNP Output
(E2FQ-X□F1)

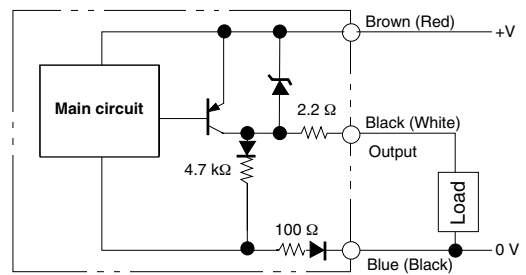

DC Two-wire Type
(E2FQ-X□D1)

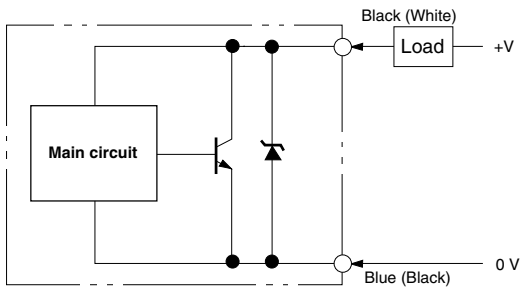

AC Switching Type
(E2FQ-X□Y1)

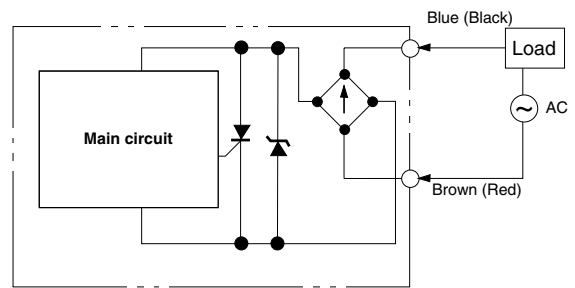

Note: IEC colors are shown in parentheses.

■ TIMING CHART

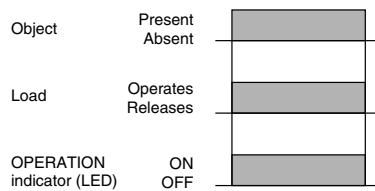

Engineering Data

OPERATING RANGE

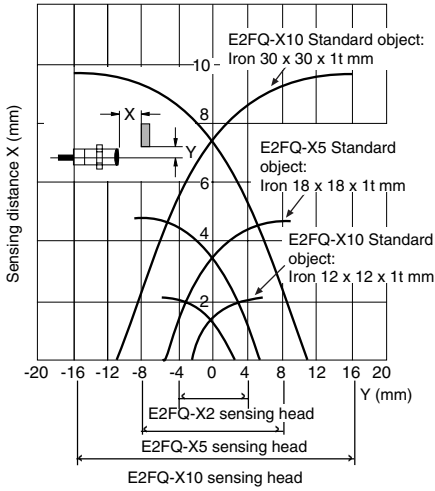

LEAKAGE CURRENT

E2FQ-X2D1, E2FQ-X5D1, E2FQ-X10D1

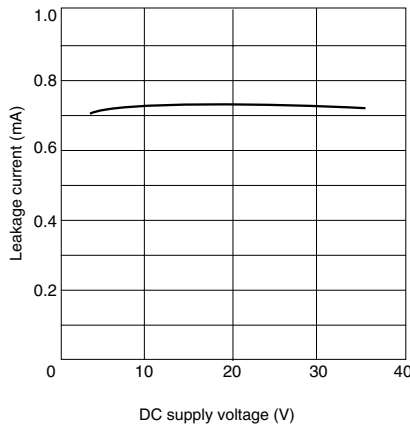

E2FQ-X5Y1, E2FQ-X10Y1

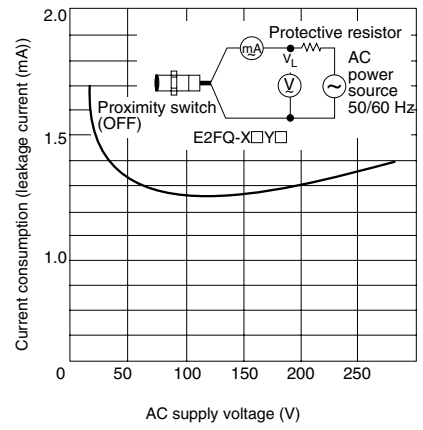

RESIDUAL LOAD VOLTAGE

E2EQ-X5Y1, E2FQ-X10Y1

(at constant 24 VAC)

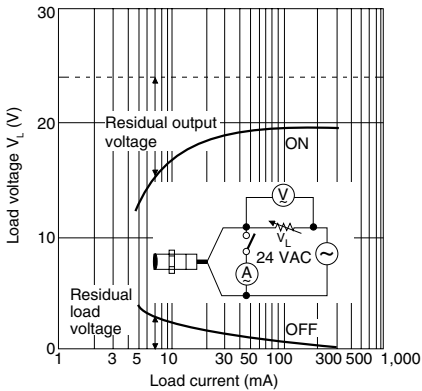

(at constant 100 VAC)

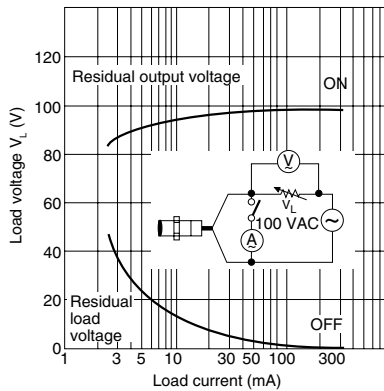

(at constant 200 VAC)

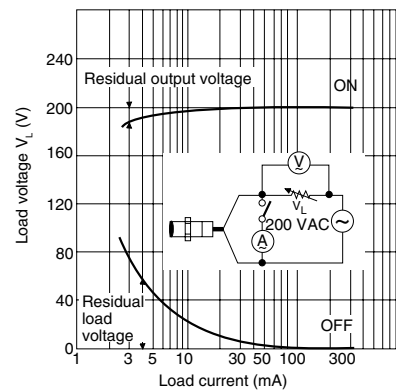

Dimensions

Unit : mm (inch)

Note: The following dimensions also apply to the models having 2 conductors.

E2FQ-X2□1

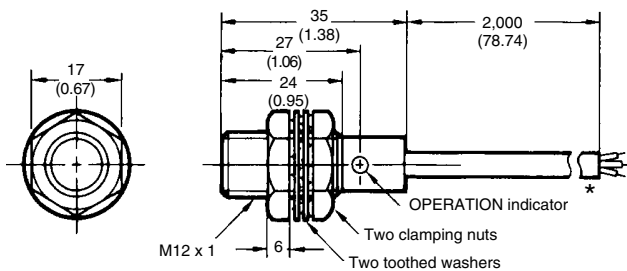

E2FQ-X5□1

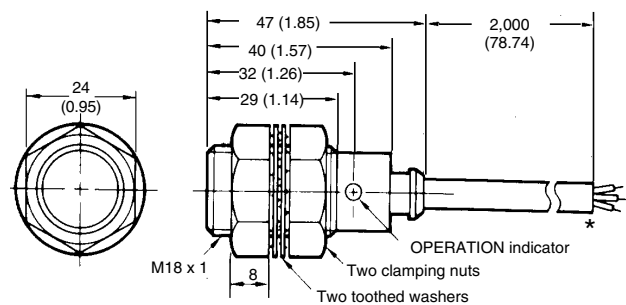

E2FQ-X10□1

Mounting holes

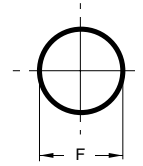
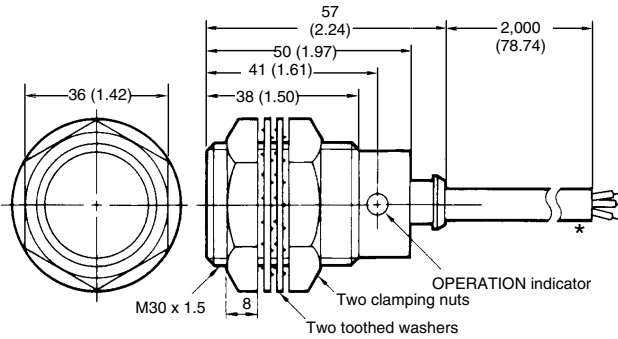

Part number	F
E2FQ-X2	12.5 ^{+0.5} ₋₀ mm (0.49 in.)
E2FQ-X5	18.5 ^{+0.5} ₋₀ mm (0.73 in.)
E2FQ-10	30.5 ^{+0.5} ₋₀ mm (1.20 in.)

* Vinyl-insulated round cable (oil-tight, 3 conductors for E2FQ-X□E1 or E2FQ-X□F1, 2 conductors for E2FQ-X□D1, 6 mm outer diameter.
Standard length: 2 m Cable can be extended to 200 m (6.56 ft.) max. in individual metal conduit.

Precautions

■ TIGHTENING FORCE

Do not exceed the torque listed in the table below when tightening the mounting nuts.

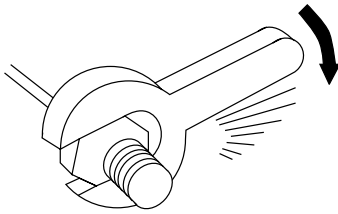

Model	Torque
E2FQ-X2	10 kgf-cm
E2FQ-X5	20 kgf-cm
E2FQ-X10	20 kgf-cm

■ EFFECTS OF SURROUNDING METALS

When mounting a proximity sensor flush with a metallic panel, provide the minimum distance shown. This prevents the sensor from being affected by metallic objects other than the target.

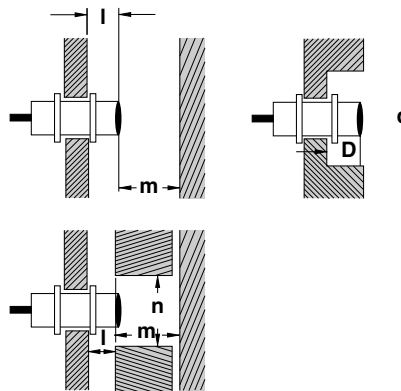

Model	E2FQ-X2	E2FQ-X5	E2FQ-X10
l	0	0	0
d	12 mm (0.47 in.)	18 mm (0.71 in.)	30 mm (1.18 in.)
D	0	0	0
m	8 mm (0.32 in.)	20 mm (0.79 in.)	40 mm (1.57 in.)
n	18 mm (0.71 in.)	27 mm (1.06 in.)	45 mm (1.77 in.)

■ MUTUAL INTERFERENCE

To prevent mutual interference between two sensors mounted opposite or parallel to each other, be sure to space the two sensors at a distance greater than that shown here.

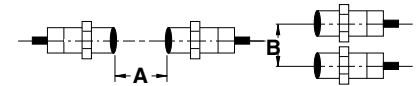

Model		Minimum distance
E2FQ-X2	A	30 mm (1.18 in.)
	B	20 mm (0.79 in.)
E2FQ-X5	A	50 mm (1.97 in)
	B	35 mm (1.38 in)
E2FQ-X10	A	100 mm (3.94 in)
	B	70 mm (2.76 in)

■ CONNECTION TO POWER SOURCE

For AC type E2FQ sensors be sure to connect the proximity sensor to the power source through a load; direct connection may damage the sensor.

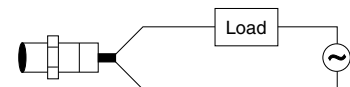

OMRON

OMRON ELECTRONICS LLC

One East Commerce Drive
Schaumburg, IL 60173

1-800-55-OMRON

OMRON ON-LINE

Global - <http://www.omron.com>
USA - <http://www.omron.com/oei>
Canada - <http://www.omron.com/oci>

OMRON CANADA, INC.

885 Milner Avenue
Scarborough, Ontario M1B 5V8
416-286-6465