

CM Series

Operating Instructions for CM-S321 & CM-S421 Coded Safety Switches

CAUTION

This information is designed to help suitably qualified personnel install and operate STI Safety Switch equipment. Before using this product, read this guide thoroughly along with any relevant European and/or National standards e.g. Machinery Directive 89/392/EEC and it's amendments, Provision and Use of Work Equipment Regulations.

Further information can be obtained from
OMRON STI

KEEP THIS GUIDE FOR FUTURE REFERENCE

Description

CM-S321/CM-S421 safety switches are a coded magnet safety switches for use in machine guarding applications.

Designed for use in applications where increased security is required, the **CM-S321/CM-S421** has a coded magnetic actuator and cannot be fully operated with a single magnet.

The **CM-S321/CM-S421** switches are designed to be connected to a safety control circuit which has less than 0.5 Amps inrush current.

The **CM-S321/CM-S421** is manufactured in a robust 316 Grade Stainless Steel housing and fully sealed to IP67 and can be used in wet / wash-down or dusty environments.

With correct installation, the **CM-S321/CM-S421** safety switches comply with the guidelines given in EN1088.

Operation

When installed on a machine guard, and the switch and actuator are within the specified operating range, the **N/C contacts** will be closed and the **N/O contacts** will be open. (See table on page 4 for switching distances)

When the actuator moves out of the operating range, the **N/C contacts** will open. The **N/O contacts** will close.

The **CM-S321/CM-S421** safety switch and actuator are designed to approach each other from most angles. When the guard is closed the targets on the printed face of the switch and actuator must be aligned.

Applications

Interlocked guards where additional security is required.
Door locking is not required.

Food and Beverage packing/filling systems
Dairy Pharmaceutical Paper Industry
Can Forming and Filling, (Aluminum, Steel, Plastic)
Semiconductor Manufacturing/Assembly.

CM-S321SC5
CM-S421SC5

CM-S321SCC
CM-S421SCC



Approvals

CE	Complies with the relevant sections of the CE marking directive.
UL	UL 508 Industrial Control Equipment

EUROPEAN DIRECTIVES

Machinery Directive 98/37/EC
Low Voltage Directive 73/23/EC
Electromagnetic Compatibility Directive 89/336/EC

EUROPEAN STANDARDS

EN292	Safety of Machinery Basic concepts, general principles for design.
EN 60204	Safety of Machinery Electrical equipment of machines.
EN 954-1 EN ISO 13849-1	Safety of Machinery Safety related parts of controls systems
EN 1088	Interlocking devices associated with guards.
EN 60947-5-3	Safety of Machinery Specification for low voltage switchgear and control gear.

Declaration of Conformity

A Declaration of Conformity can be obtained from the OMRON STI Web Site: WWW.STI.COM

DIMENSIONS

CM-S321

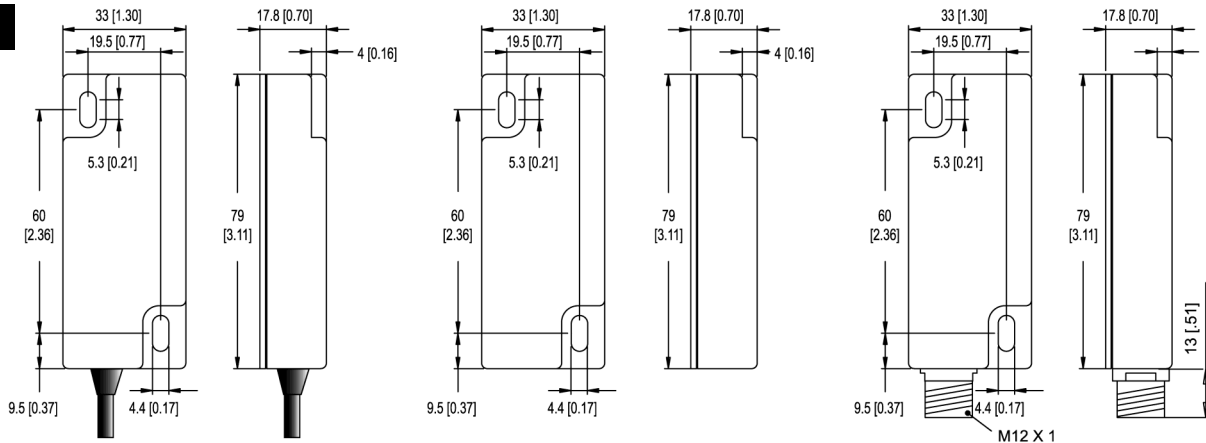

CM-S421

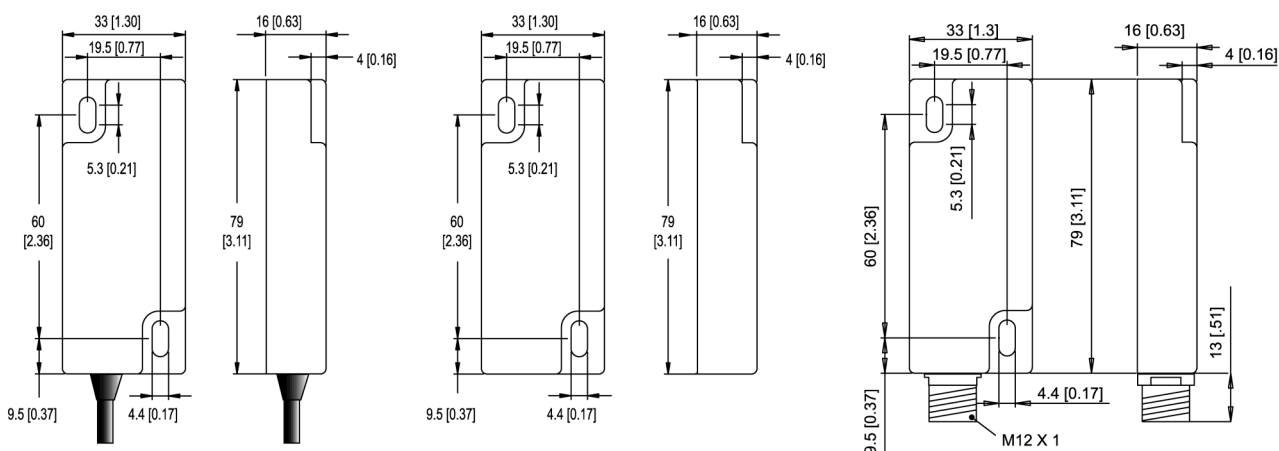

MOUNTING

The CM-S321/CM-S421 safety switches can approach each other from most angles. When the guard is closed the targets on the printed face of the switch and actuator must be aligned.

Mount the switch on to the machine frame and the actuator on to the opening edge of the door. Always try to mount the switch on non-ferrous material. (*Ferrous materials may reduce the switching distance.*)

Use the tamper proof screws provided to make the installation more secure.

Do not use the safety switch as a door stop. Leave a minimum of 50 mm between any adjacent switches.

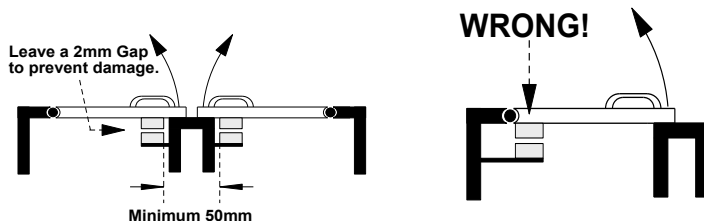
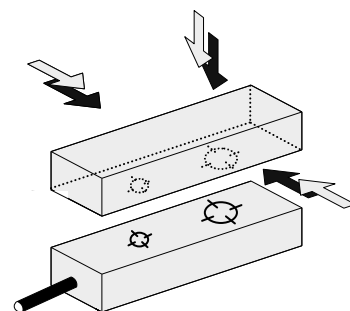

EN 1088

Provides some mounting suggestions, see example opposite.

When mounting the safety switch to a sliding door (A), ensure that when the door is opened (B) it is not easily accessible, helping to prevent the system from being overridden.

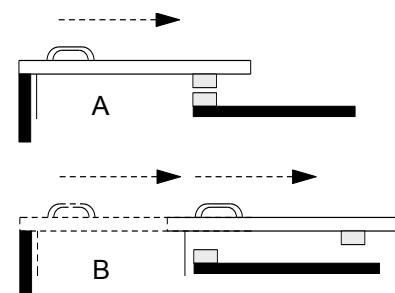

CONTACTS, CONNECTIONS

CM-S321 / CM-S421 2xN/C+1xN/O Pre-wired

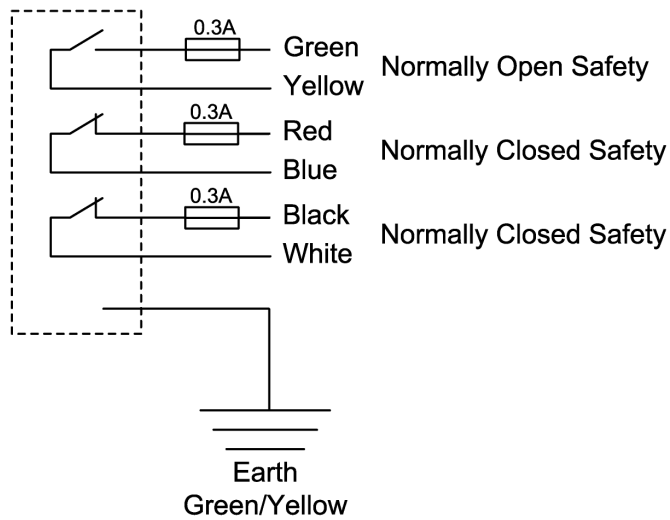

NOTE : Contacts shown when the actuator is in place.

CM-S321CC / CM-S421 2xN/C+1xN/O M12 Connector

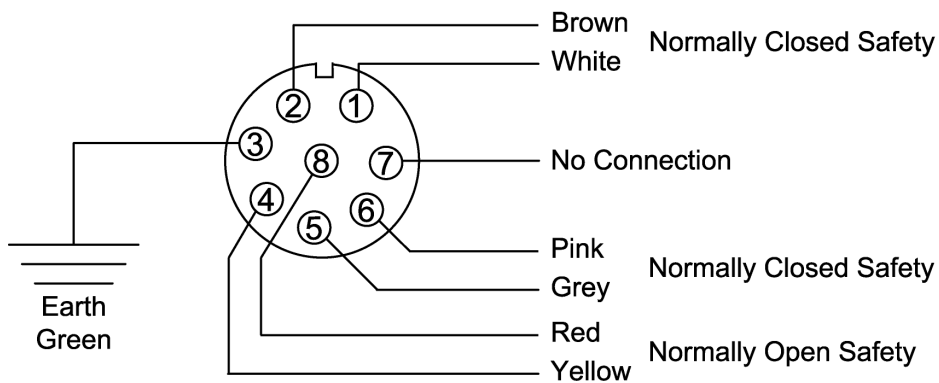

The CM-S321 is available with an IP67, 8 pole connector.
Connector specification: 8-pin, Micro Single Key-way, M12 x 1

FUSES (External)

		FUSE
CM-S321 / CM-S421	N/O Contacts	0.3 Amps
	N/C Contacts	0.3 Amps

All external fuses should be 'FAST ACTING'

TECHNICAL SPECIFICATION

PRODUCT	CM-S321	CM-S421
Contact Arrangements	2 x N/C + 1 x N/O	2 x N/C + 1 x N/O
N/C Safety Contact Rating	24Vdc / 0.3Amp Inductive/Resistive	24Vdc / 0.3Amp Inductive/Resistive
N/C Safety Contact Operating Distance	7mm ON / 10mm OFF	7mm ON / 10mm OFF
N/C Safety Contact Close/Drop/Bounce	3ms / 2.1ms / 0.7ms	3ms / 2.1ms / 0.7ms
N/O Safety Contact Rating	24Vdc / 0.3Amp Inductive/Resistive	24Vdc / 0.3Amp Inductive/Resistive
N/O Safety Contact Operating Distance	7mm OFF / 10mm ON	7mm OFF / 10mm ON
N/O Safety Contact Close/Drop/Bounce	0.5ms / 0.3ms / 0.7ms	0.5ms / 0.3ms / 0.7ms
External Fuse (Customer Supplied)	0.3 Amp Fast Acting	0.3 Amp Fast Acting
IP Rating	IP67	IP67
Vibration / Shock	50—100Hz / 10g	50—100Hz / 10g
Operating Temperature	Pre-wired	-10°C to +95°C
	Quick Disconnect	-10°C to +55°C
Mounting & Fixture	Target to Target	Target to Target
Connection	Pre-wired or Quick Disconnect	Pre-wired or Quick Disconnect
Construction	316 Grade Stainless Steel with backing plate	316 Grade Stainless Steel

Specification Changes

In the interest of product development, specifications are subject to change without notice.

Note

The N/C contacts of the STI switches are described as normally closed (N/C) when the guard closed, actuator in place, and the machine able to be started. The N/O contacts are open when the guard is open.



OMRON SCIENTIFIC TECHNOLOGIES, INC.

6550 Dumbarton Circle, Fremont CA 94555-3605 USA

Tel: 1/510/608-3400

Fax: 1/510/744-1442

E-mail: sales@sti.com

www.sti.com

OMRON AUTOMATION AND SAFETY • THE AMERICAS HEADQUARTERS • Chicago, IL USA • 847.843.7900 • 800.556.6766 • www.omron247.com

OMRON CANADA, INC. • HEAD OFFICE

Toronto, ON, Canada • 416.286.6465 • 866.986.6766 • www.omron247.com

OMRON ELECTRONICS DE MEXICO • HEAD OFFICE

México DF • 52.55.59.01.43.00 • 01-800-226-6766 • mela@omron.com

OMRON ELECTRONICS DE MEXICO • SALES OFFICE

Apodaca, N.L. • 52.81.11.56.99.20 • 01-800-226-6766 • mela@omron.com

OMRON ELETRÔNICA DO BRASIL LTDA • HEAD OFFICE

São Paulo, SP, Brasil • 55.11.2101.6300 • www.omron.com.br

OMRON ARGENTINA • SALES OFFICE

Cono Sur • 54.11.4783.5300

OMRON CHILE • SALES OFFICE

Santiago • 56.9.9917.3920

OTHER OMRON LATIN AMERICA SALES

54.11.4783.5300

OMRON EUROPE B.V. • Wegalaan 67-69, NL-2132 JD, Hoofddorp, The Netherlands. • +31 (0) 23 568 13 00 • www.industrial.omron.eu

Authorized Distributor:

Automation Control Systems

- Machine Automation Controllers (MAC) • Programmable Controllers (PLC)
- Operator interfaces (HMI) • Distributed I/O • Software

Drives & Motion Controls

- Servo & AC Drives • Motion Controllers & Encoders

Temperature & Process Controllers

- Single and Multi-loop Controllers

Sensors & Vision

- Proximity Sensors • Photoelectric Sensors • Fiber-Optic Sensors
- Amplified Photomicrosensors • Measurement Sensors
- Ultrasonic Sensors • Vision Sensors

Industrial Components

- RFID/Code Readers • Relays • Pushbuttons & Indicators
- Limit and Basic Switches • Timers • Counters • Metering Devices
- Power Supplies

Safety

- Laser Scanners • Safety Mats • Edges and Bumpers • Programmable Safety Controllers • Light Curtains • Safety Relays • Safety Interlock Switches