

# G9SX SAFETY CONTROLLER

Scalable hardwired solution



- » Hardware configured, no programming
- » Easy wiring & installation
- » Clear diagnosis & monitoring

# Tailored to your safety application

*Omron G9SX safety controllers are supplied fully configured and pre-programmed, with a wide choice of units designed to be fit for purpose, with no unnecessary functionality.*

*Ideal for use where the flexibility of a programmable safety controller is not needed, G9SX units are simple to fit and very robust, with non-wearing solid state outputs.*

*They can be easily connected on modular equipment, and are ideal for non-contact applications where a high number of output cycles is needed. Next to these benefits of the G9SX controllers, Omron provides services locally, worldwide.*

## Optimised hardwired solutions

G9SX controllers have pre-defined hardware function-blocks to offer precise, specific solutions that are ideally suited to your application. Each model in the range offers different characteristics, and they all come fully configured and ready for installation. Individual units can be connected together using inbuilt logic functions, to implement safety control over separate machine functions for complete security. Expansion units with timing functions are also available within the range.

## No programming, no special tools

All G9SX controllers are pre-programmed and can be connected easily, with no special tools, no software. Removable terminal blocks make installation and replacement straightforward. Validation as a result is easy since there are no special tools needed.



## Robust and reliable

G9SX controllers feature solid-state inputs and outputs, with no moving parts and no programming. This makes them both robust and reliable, particularly in harsh environments or where there is heavy vibration. Smart feedback and front-mounted LED displays offer clear and detailed diagnostics diagnosis at all times for simple maintenance and control.

## Motion monitoring

Monitoring of motion incorporated in the G9SX range address the demand of safe monitoring of movement. A standstill monitoring unit as well as a limited speed monitoring unit makes the safe control of your actuators easier than ever before.

## Scalable safety solution meeting the variety of need in your market today

Depending on the level of your safety control requirements, Omron offers the solutions in a smooth and scalable way.

For a straight forward tailored safety solution to fit your applications. We offer with the G9SX-series a complete range of fully configured, pre-programmed safety controllers.

For fast and flexible safety solutions, Omron' programmable safety controllers, offer the efficiency and consistency needed, to protect your investment.

## Delivering local services - worldwide

Every Omron customer benefits from global support tailored precisely to local needs. Wherever you are, wherever your machines are manufactured or installed, you can rely on the same high standards of service support, engineering back-up and parts supply. We focus totally on your needs.





# Logical and switchable monitoring on standalone machine

One of the most important applications for G9SX units is to provide switchable monitoring of standalone machining centres. The availability of multi-channel inputs and a choice of solid-state safety outputs give G9SX-BC, G9SX-AD, G9SX-ADA and G9SX-NS units a high degree of flexibility. This makes them ideal installations that require full and partial shutdown, and/or instantaneous or delayed action. All G9SX safety controllers are certified according to ISO13849-1.

## The functionality you need

G9SX-AD and G9SX-ADA units can be linked together to provide either complete and instantaneous shut-down (if the emergency-stop button is pressed) or partial shutdown of the machining area (if the safety light curtain is breached). This logical and connective control enables machining centres to be used in complete safety, while minimising downtime caused by unnecessary full shutdown/restart. This precise functionality optimises machine use, eliminating the cost of irrelevant features.

- Complete or partial shutdown
- Instantaneous or delayed action
- Easy installation and clear monitoring
- Complete operator safety with optimum efficiency



### Operation Example

(1) The Emergency Stop Switch is pressed

(2) Safety Light Curtain is interrupted

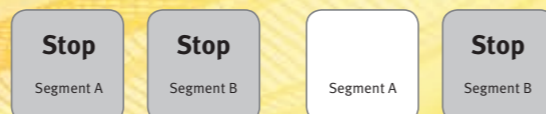

# Reliable solid-state function for increased uptime

G9SX-NS controllers are ideal for monitoring applications such as non-contact door switches. Solid-state hardware function-blocks provide a vibration-proof detection mechanism that is entirely stable, reducing controller errors – for example, as a result of false door-movements – to a minimum. A single controller can monitor up to 30 non-contact door switches, each with separate two-colour LED indicators that identify both door status and cable disconnections.

- Monitoring of non-contact (actuator and sensor) door switches
- No physical contact
- No wear, no abrasion, therefore no dust particles
- Ideal for packaging, food and pharmaceutical industries



### Operation Example

(1) The Emergency Stop Switch is pressed

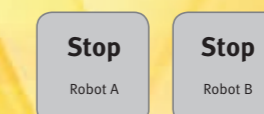

(2) Robot door A opened

(3) Robot door B opened





## Movement monitoring for total peace of mind

There are many applications where the movement of potentially dangerous machinery and equipment must be carefully controlled, to safeguard personnel, products and the equipment itself. G9SX-SM controllers are designed to monitor full standstill. The controllers are self-contained units and can be easily connected to the inverter system, to minimise external wiring, simplify installation and ensure easy monitoring of safety issues.

- Safe-standstill monitoring for both two- and three-phase systems
- Ready to use without additional setup or special programming
- Easy integration into both star- and delta-wiring
- Clear LED diagnosis of all input and output signals

### Standstill monitoring

In applications such as this wrapping machine in a fenced area, it is essential that the machine is at a complete standstill before personnel enter the fenced area. The G9SX, integrated with an inverter system, provides comprehensive monitoring and control for failsafe and reliable shutdown.

### Limited speed monitoring

In applications such as this windfarm rotor, the speed of the rotor must be limited for example, to prevent damage to the mechanism itself through excess speeds in high-winds. Speed limits are also necessary to support safe maintenance operation, for example, in tooling machines. The G9SX-LM, in conjunction with Omron's patented inverter series, ensures a long and reliable working life for all such equipment.

- Monitoring unit for complete support of maintenance mode in machinery
- Preset of limited speed frequency by using integrated preset switches
- Easy integration in G9SX-Systems by using unique logical "AND" connection
- Clear LED diagnosis for easy maintenance

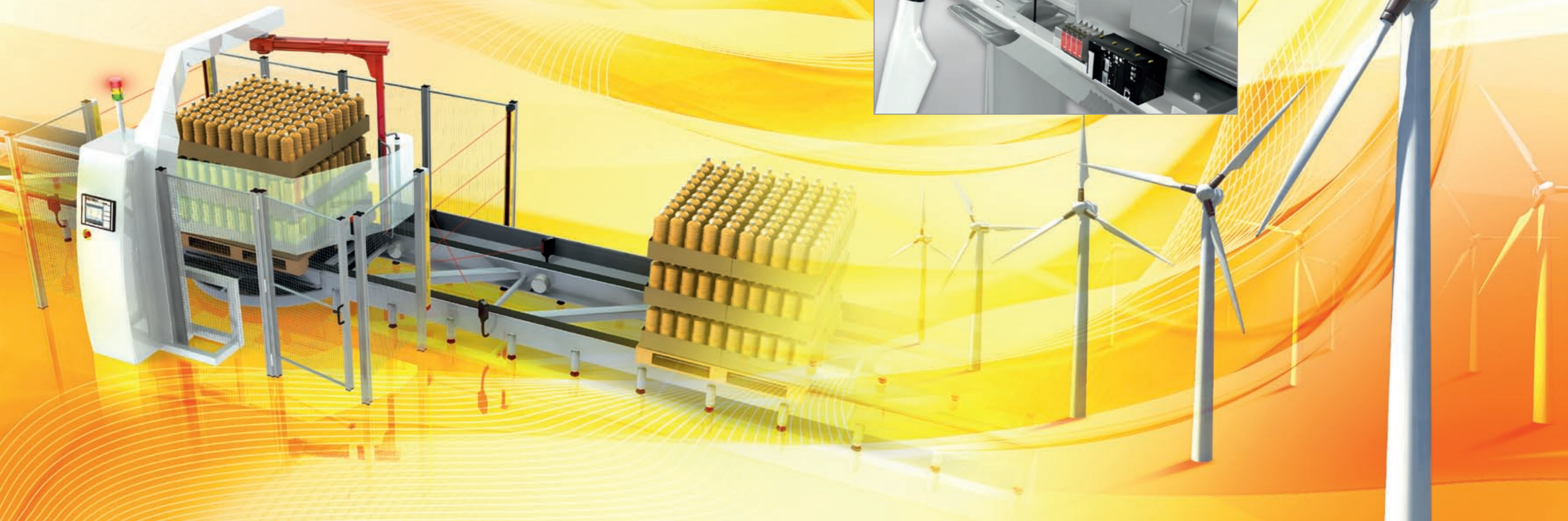



# Robot cell monitoring

Modern production lines rely on robots for quality and high productivity. To maximise these benefits, maintenance on robots must be conducted quickly and efficiently, while protecting both operators and maintenance personnel. G9SX control units provide the control and monitoring of robot operation to achieve this, ensuring safety while maximising machine uptime.

- Safety guard switching under complete control
- Transparent segmentation of safety functions with logical "AND" connection
- Clear LED diagnosis of all signals for easy maintenance
- Suitable for both auto- and manual-switching applications

## Guard-switching unit on machining robot

Simplified maintenance and increased productivity is achieved in this machining robot by automatically switching between two safety zones. The robot operates in two cells, each secured by a separate safety light curtain, each of which is controlled by a single G9SX-GS switching unit. When the robot operates at the back of the machine, the operator can prepare the next batch of material to be processed, because safety light curtain A is active and safety light curtain B is inactive. When the robot pulls the next batch through, curtain A is inactive and curtain B is active – so the operator is kept outside of the hazardous area. Switching is completely automatic, using position-monitoring switches on the robot itself.

## Operator-switched control for robot maintenance

When robots need to be maintained or reconfigured, it is often necessary to have movement control that can be limited but positive – for example for repositioning a robot arm to enable tool changing. Here a G9SX-GS switching unit provides positive control over the robot operation, with the machine stopping immediately when the switch is released. With exceptionally fine control, the machine can be moved into position in complete safety, while protecting the maintenance staff.

- Positive control over limited movement
- Security and peace of mind for operators
- Ensures fast and effective maintenance and reconfiguring
- Reduces downtime to a minimum – safely



Safe maintenance or setup operation is supported by direct connection of hold-to-run device A4EG.

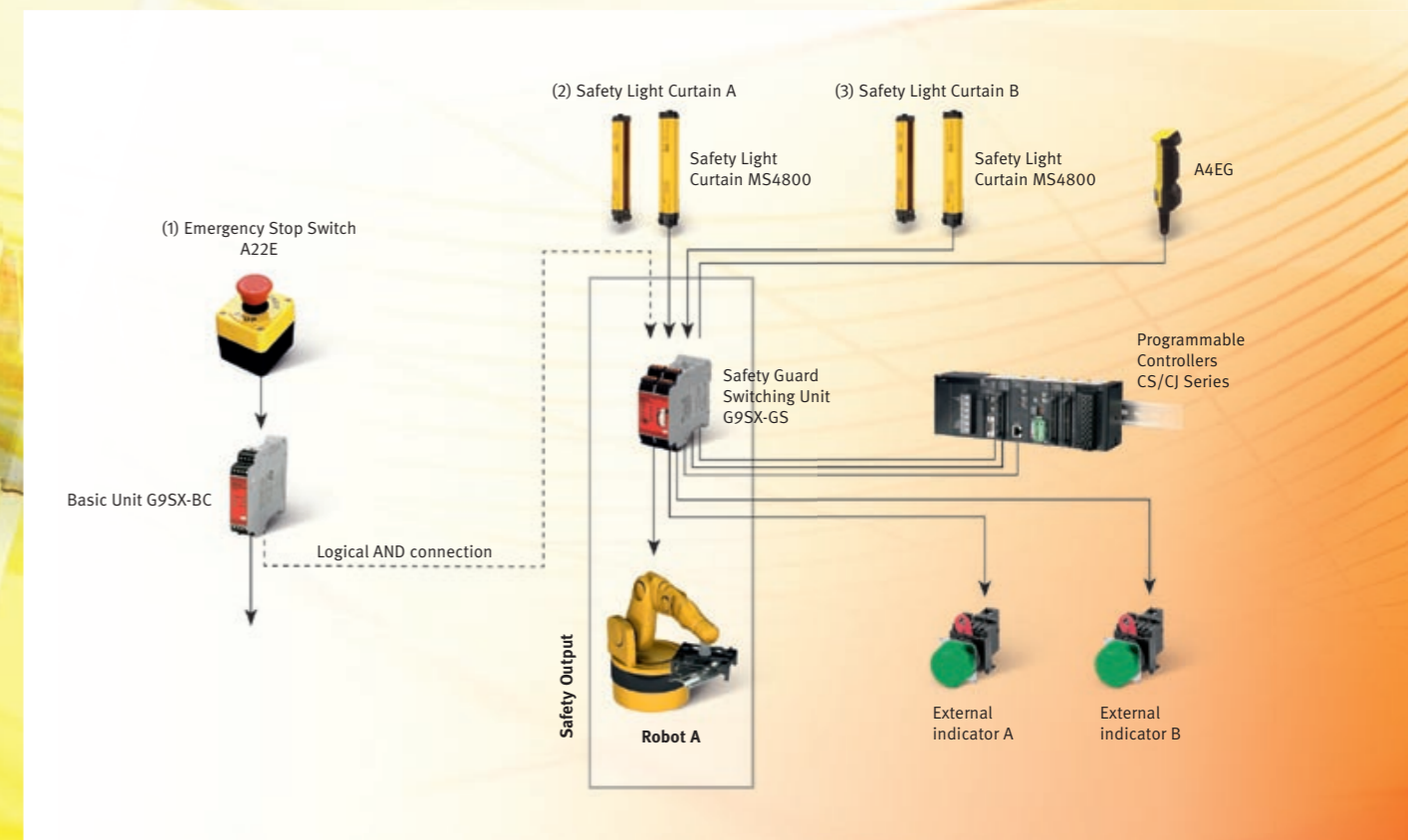
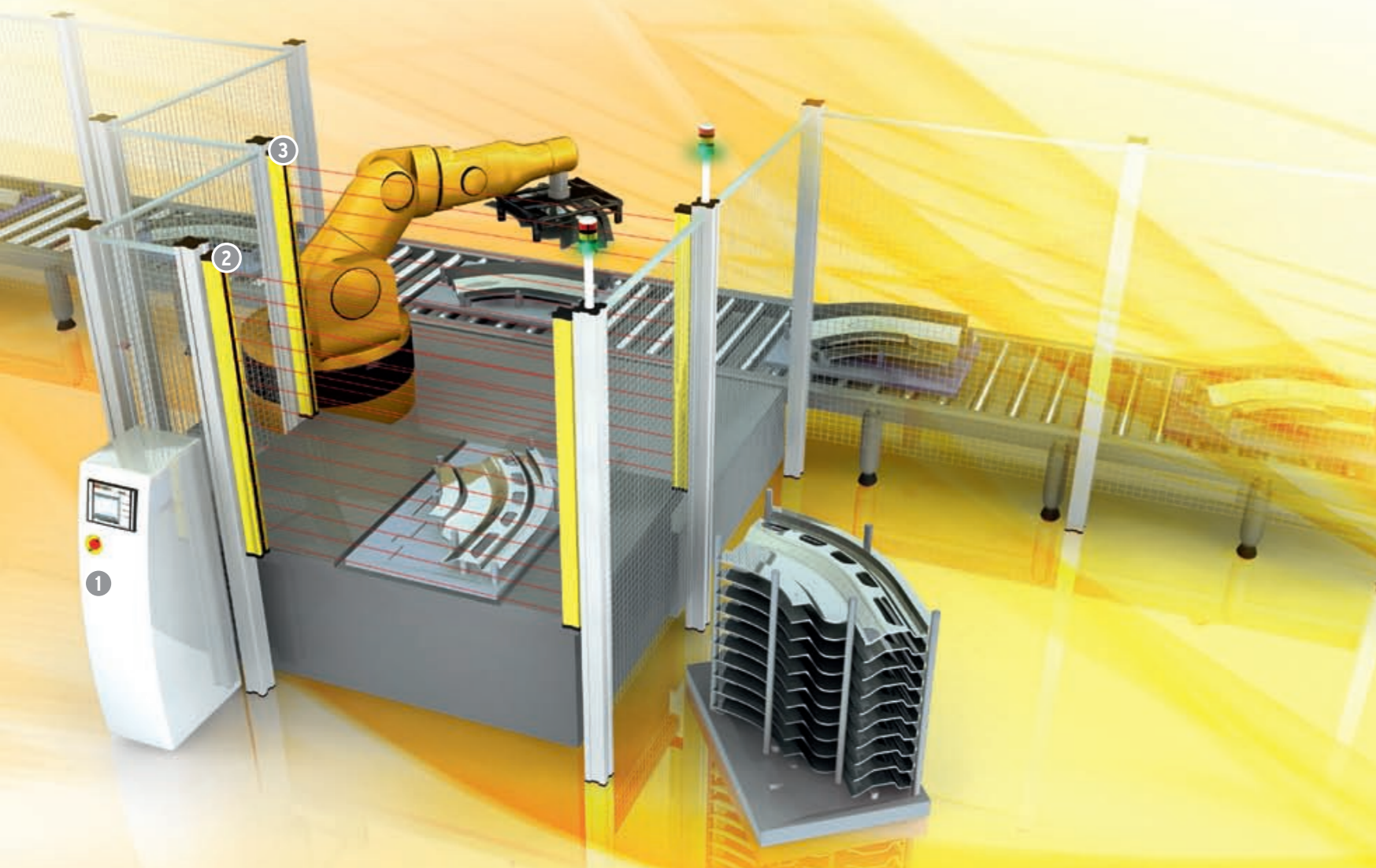





## Flexible safety unit

G9SX-family modules can be connected by a logical "AND" function to implement partial/global stopping of a machine. Solid-state outputs, detailed LED diagnosis and clever feedback signals help to keep maintenance easy. The line-up is completed by expansion units with safe timing functions.

- Clear and transparent segmentation of safety functions by use of unique "AND" connection
- Solid-state outputs for long life and relay outputs in extension box available
- Detailed LED indications enable easy diagnosis
- Clever feedback signals for easy maintenance
- Category-4 according to EN954-1 and SIL 3 according to EN 61508

## Ordering information

### Advanced unit

Safety outputs		Auxiliary outputs	No. of input channels	Max. OFF-delay time <sup>*1</sup>	Rated voltage	Terminal block type	Order code
Instantaneous	OFF-delayed						
3 P channel MOS-FET transistor output	2 P channel MOS-FET transistor output	2 PNP transistor outputs	1 or 2 channels	0 to 15 sec in 16 steps	24 VDC	Screw terminals Cage clamp terminals	G9SX-AD322-T15-RT G9SX-AD322-T15-RC
2 P channel MOS-FET transistor output	2 P channel MOS-FET transistor output	2 PNP transistor outputs	1 or 2 channels	0 to 150 sec in 16 steps	24 VDC	Screw terminals Cage clamp terminals	G9SX-AD-322-T150-RT G9SX-AD-322-T150-RC
				0 to 15 sec in 16 steps	24 VDC	Screw terminals Cage clamp terminals	G9SX-ADA-222-T15-RT G9SX-ADA-222-T15-RC
				0 to 150 sec in 16 steps	24 VDC	Screw terminals Cage clamp terminals	G9SX-ADA-222-T150-RT G9SX-ADA-222-T150-RC

\*1 The OFF-delay time can be set in 16 steps as follows: T15: 0/0.2/0.3/0.4/0.5/0.6/0.7/1/1.5/2/3/4/5/7/10/15 s, T150: 0/10/20/30/40/50/60/70/80/90/100/110/120/130/140/150 s.

### Basic unit

Safety outputs		Auxiliary outputs	No. of input channels	Rated voltage	Terminal block type	Order code
Instantaneous	OFF-delayed					
2 P channel MOS FET transistor output	–	2 PNP transistor output	1 or 2 channels	24 VDC	Screw terminals Cage clamp terminals	G9SX-BC202-RT G9SX-BC202-RC

### Expansion unit

Safety outputs		Auxiliary outputs	OFF-delay time	Rated voltage	Terminal block type	Order code
Instantaneous	OFF-delayed					
4 PST-NO (contact)	–	2 (solid state) PNP transistor outputs	–	24 VDC	Screw terminals Cage clamp terminals	G9SX-EX401-RT G9SX-EX401-RC
–	4 PST-NO (contact)	Synchronized with G9S-X-AD - unit	–	24 VDC	Screw terminals	G9SX-EX041-T-RT
					Cage clamp terminals	G9SX-EX041-T-RC

## Specifications

### Power input

Item	G9SX-AD_	G9SX-BC202_	G9SX-EX_	Item	G9SX-AD_	G9SX-BC202_
Rated supply voltage	20.4 to 26.4 VDC (24 VDC -15% +10%)			Safety input	Operating voltage: 20.4 VDC to 26.4 VDC, internal impedance: Approx. 2.8 kΩ	
				Feedback/reset input		

### Outputs

Item	G9SX-AD_	G9SX-BC202_
Instantaneous safety output	P channel MOS FET transistor output	
OFF-delayed safety output	Load current: Using 2 outputs or less: 1 A DC max. Using 3 outputs or more: 0.8 A DC max.	
Auxiliary output	PNP transistor output Load current: 100 mA max.	

### Expansion unit

Item	G9SX-EX_
Rated load	250 VAC, 3A/30 VDC, 3A (resistive load)
Rated carry current	3 A
Maximum switching voltage	250 VAC, 125 VDC

### Characteristics

Item	G9SX-AD_	G9SX-BC202_	G9SX-EX_
Operating time (OFF to ON state)	50 ms max. (Safety input: ON) 100 ms max. (Logical AND connection input: ON)	50 ms max. (Safety input: ON)	30 ms max.
Response time (ON to OFF state)	15 ms max.		
Durability	Electrical	–	
	Mechanical	–	
Ambient temperature	-10°C +55°C (with no icing or condensation)		



## Compact non-contact door switch/ flexible safety unit

Electronic detection mechanism for better stability in non-contact door switch operation

- Stable operation reduces controller errors caused by unstable doors.
- Connect up to 30 non-contact door switches with LED indicators to one controller.
- Reversible switch provides flexibility in installation.
- Two-color LED indicator enables easier maintenance by identification of door status and cable disconnections.
- Safety category 3 (EN 954-1).

## Ordering information

### Non-contact door switches (Switch/Actuator)

Classification	Auxiliary outputs	Cable length	Order code
Standard models	Semiconductor outputs <sup>*1</sup>	2 m	D40A-1C2
		5 m	D40A-1C5

\*1 PNP open-collector semiconductor output.

Note: Must be used in combination with a G9SX-NS\_ non-contact door switch controller.

### On-contact door switch controllers (Controllers for D40A)

Safety outputs <sup>*1</sup>		Auxiliary outputs <sup>*2</sup>	Logical AND connection input	Logical AND connection output	Max. OFF delay time <sup>*3</sup>	Rated voltage	Terminal block type	Order code
Instantaneous	OFF-delayed <sup>*4</sup>							
2 (Semi-conductors)	0	2 (Semi-conductors)	1	1	–	24 VDC	Screw terminals	G9SX-NS202-RT
	2 (Semi-conductors)	–	–	–	3.0 s		Spring-cage terminals	G9SX-NS202-RC
							Spring-cage terminals	G9SX-NSA222-T03-RT
							Spring-cage terminals	G9SX-NSA222-T03-RC

\*1 P channel MOS FET transistor output

\*2 PNP transistor output

\*3 The OFF-delay time can be set in 16 steps as follows:  
0/0.2/0.3/0.4/0.5/0.6/0.7/0.8/0.9/1.0/1.2/1.4/1.8/2.0/2.5/3.0 s

\*4 The OFF-delayed output becomes an instantaneous output by setting the OFF-delay time to 0 s.

## Specifications

### Ratings/Characteristics of non-contact door switches

Item	Model	D40A-1C_
Operating characteristics <sup>*1</sup>	Operating distance OFF→ON	5 mm min.
	Operating distance ON→OFF	15 mm max.
	Differential travel (max.)	20% of operating distance
Ambient operating temperature	-10 to 55°C (no icing or condensation)	
Vibration resistance	10 to 55 to 10 Hz (single amplitude: 0.75 mm, double amplitude: 1.5 mm)	
Shock resistance	300 m/s <sup>2</sup> min.	
Degree of protection	IP67	
Material	PBT resin	
Mounting method	M4 screws	
Power consumption	0.6 W max.	
Auxiliary outputs <sup>*2</sup>	24 VDC, 10 mA (PNP open-collector outputs)	
LED indicators	Actuator not detected (red); actuator detected (yellow)	
Connection cables	2 m, 5 m	
Number of connectable switches	30 max. (wiring length: 100 m max.)	

\*1 This is the distance where the switch operates from OFF to ON when approaching and the distance where the switch operates from ON to OFF when separating when the switch and actuator target marks are on the same axis, and the sensing surfaces coincide.

\*2 Turns ON when the actuator is approaching.



### Safety guard switching unit

The safety controller to support maintenance mode of machinery in the safe way.

- Two operation modes to support:
  - Auto switching for applications where machine and worker co-operate.
  - Manual switching for applications with limitation in operation like maintenance.
- Clear and transparent segmentation of safety functions by use of unique "AND" connection
- Clear LED diagnosis of all in- and output signals for easy maintenance
- Category 4 according to EN954-1 and SIL 3 according to EN 61508.

### Ordering information

#### Enabling grip switches

Contact form			Order code
Enabling switch	Monitor switch	Pushbutton switch	
Two contacts	1NC (grip output)	None	A4EG-C000041
Two contacts	None	Emergency stop switch (2NC)	A4EG-BE2R041
Two contacts	None	Momentary operation switch (2NO)	A4EG-BM2B041

#### Safety Guard Switching Units

Safety outputs <sup>*1</sup>		Auxiliary outputs <sup>*2</sup>	Logical AND connection input	Logical AND connection output	Max. OFF delay time <sup>*3</sup>	Rated voltage	Terminal block type	Order code
Instantaneous	OFF-delayed <sup>*4</sup>							
2 (Semi-conductors)	2 (Semi-conductors)	6 (Semi-conductors)	1	1	15 s	24 VDC	Screw terminals	G9SX-GS226-T15-RT
							Spring-cage terminals	G9SX-GS226-T15-RC

<sup>\*1</sup> P channel MOS FET transistor output

<sup>\*2</sup> PNP transistor output

<sup>\*3</sup> The OFF-delay time can be set in 16 steps as follows:

T15: 0, 0.2, 0.3, 0.4, 0.5, 0.6, 0.7, 1, 1.5, 2, 3, 4, 5, 7, 10 or 15 s

<sup>\*4</sup> The OFF-delayed output becomes an instantaneous output by setting the OFF-delay time to 0 s.

### Specifications

#### Ratings of non-contact door switch controllers

##### Power input

Item	G9SX-GS226-T15-__	G9SX-EX-__
Rated supply voltage	24 VDC	

##### Inputs

Item	G9SX-GS226-T15-__
Safety input	Operating voltage: 20.4 VDC to 26.4 VDC, internal impedance: approx. 2.8 kΩ
Feedback/reset input	
Mode selector input	

##### Outputs

Item	G9SX-G9SX-GS226-T15-__
Instantaneous safety output	P channel MOS FET transistor output
OFF-delayed safety output	Load current: 0.8 A DC max.
Auxiliary output	PNP transistor output Load current: 100 mA max.
External indicator outputs	P channel MOS FET transistor outputs Connectable indicators <ul style="list-style-type: none"> <li>• Incandescent lamp: 24 VDC, 3 W to 7 W</li> <li>• LED lamp: 10 to 300 mA DC</li> </ul>

### Application example

#### Automatic switching mode

Worker is loading and unloading the machine manually. When loading is finished, robot cycle is started manually by the worker. When robots return to their home position, loading cycle is selected automatically.

Loading Condition: Safety Sensor B is not active, Safety Sensor A is active because the robots are not allowed to move to the loading area while the worker loads the machine. So the worker is safe because Safety Sensor A is active.

Robot Work Condition: Safety Sensor B is active, Safety Sensor A is not active because the worker is not allowed to move to the loading area when the robots work. So the worker is safe because Safety Sensor B stops the machine if he moves to the loading area.

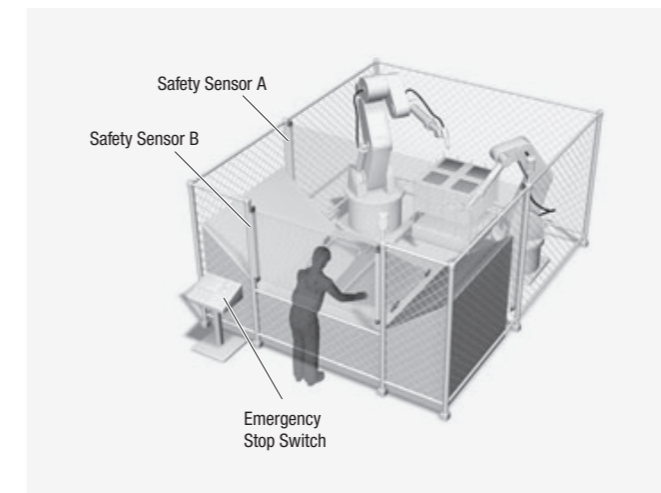

#### Manual switching mode

Worker has to do maintenance in this machine. While maintenance, it is necessary to move the machine in a limited way. The worker has to select automatic mode or manual mode manually by using the mode selector switch.

Operation steps:

- 1) Select Maintenance mode by using the mode selector
- 2) Open the door to do the maintenance while the machine still is able to operate in a limited way (monitoring of limited movement by using the safety limit switch).
- 3) Close the cover after finishing maintenance
- 4) Select Automatic mode by using the mode selector

E-Stop conditions:

- a) open the door while not in maintenance mode
- b) the machine actuates the limit switch (breaks the limit).
- c) the Enabling grip switch A4EG is actuated to stop the machine in emergency condition.

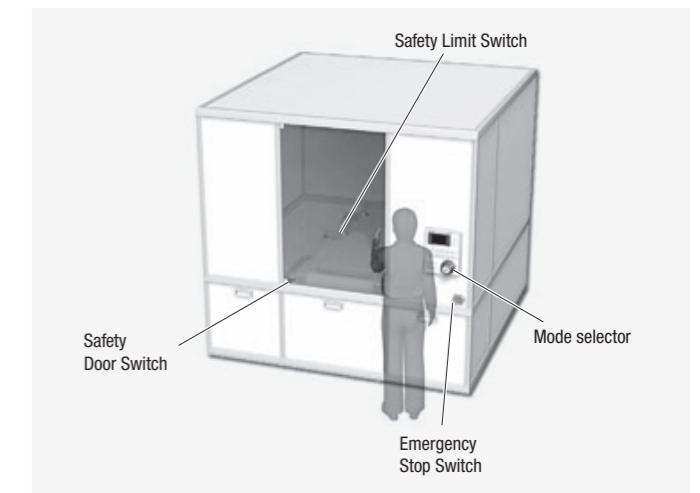



**Standstill monitoring unit**

Safe Standstill monitoring unit based on Back-EMF operation for two- and three-phase systems.

- Ready to use – covering all standard applications without additional setup
- Easy integration in star- and delta wiring
- Clear LED diagnosis of all in- and output signals for easy maintenance
- Applicable up to Safety Category 4 according to EN954-1

**Ordering information**

**Safety standstill monitoring unit**

Safety outputs *1	Auxiliary outputs *1	Power input Rated supply voltage	Terminal block type	Order code
Instantaneous				
3 (Semi-conductors)	2 (Semi-conductors)	24 VDC	Screw terminals	G9SX-SM032-RT
			Spring-cage terminals	G9SX-SM032-RC

\*1 PNP transistor output

**Specifications**

**Ratings of non-contact door switch controllers**

**Power input**

Item	G9SX-SM032-__
Rated supply voltage	24 VDC

**Inputs**

Item	G9SX-SM032-__
Input Voltage	Standstill detection input (Z1-Z2/Z3-Z4) AC 415 Vrms + 10% max.
Maximum power supply frequency for AC induction motor	60 Hz max.
Internal impedance	Standstill detection input: approx. 660 kΩ EDM input: approx. 2.8 kΩ

**Outputs**

Item	G9SX-SM032-__
Safety Standstill detection output	Sourcing output (PNP) Load current: 300 mA DC max.
Auxiliary output	Sourcing output (PNP) Load current: 100 mA DC max.

**Application example**

**3-phase motor**

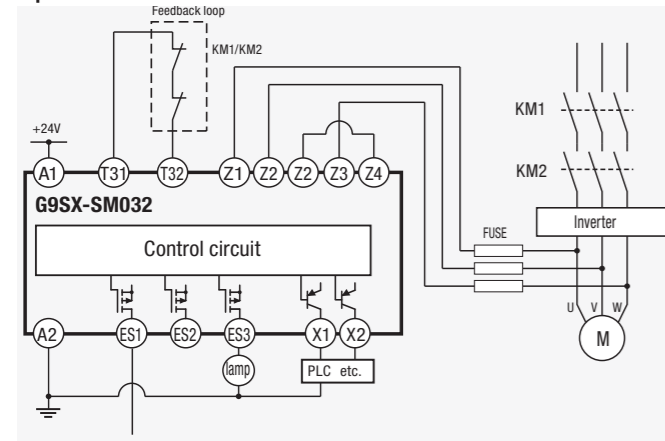

Standstill detected

**3-phase motor with star-delta wiring**

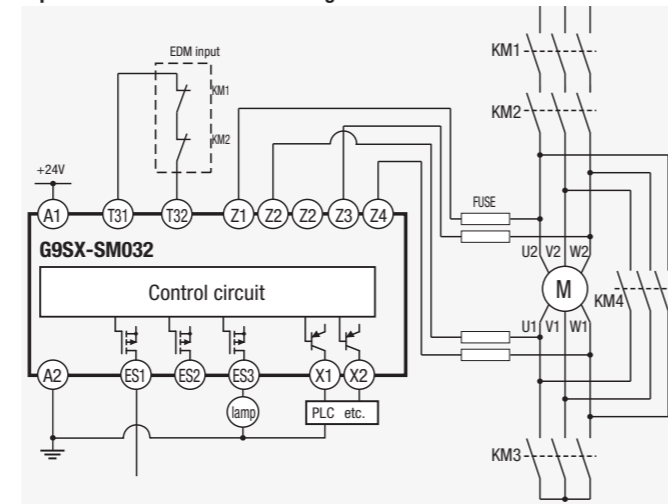

Standstill detected



**Limited speed monitoring unit**

Safe Limited Speed monitoring unit for complete support of maintenance mode in machinery.

- Preset of limited speed frequency by using integrated preset switches
- Easy integration in G9SX-Systems by using unique logical "AND" connection
- Clear LED diagnosis of all in- and output signals for easy maintenance
- Applicable up to Safety Category 3 according to EN954-1 using Omron proximity sensors

**Ordering information**

**Proximity sensors**

Classification			Order code
Proximity sensor	Shielded	M8	E2E-X1R5F1
		M12	E2E-X2F1
		M18	E2E-X5F1
	Unshielded	M8	E2E-X2MF1
		M12	E2E-X5MF1
		M18	E2E-X10MF1

**Safety standstill monitoring unit**

Safety outputs *1	Auxiliary outputs *2	Logical AND connection input	Rated voltage	Sensor power supply terminals	Terminal block type	Order code
Instantaneous						
4 (Semi-conductors)	4 (Semi-conductors)	1	24 VDC	2	Screw terminals	G9SX-LM224-F10-RT
					Spring-cage terminals	G9SX-LM224-F10-RC

\*1 P channel MOS FET output

\*2 PNP transistor output

**Specifications**

**Ratings of non-contact door switch controllers**

**Power input**

Item	G9SX-LM224-F10-__
Rated supply voltage	24 VDC

**Inputs**

Item	G9SX-LM224-F10-__
Safety input	Operating voltage: 20.4 VDC to 26.4 VDC
Feedback/reset input	Internal impedance: approx. 2.8 kΩ
Mode selector input	
Rotation detection input	Operating voltage 20.4 VDC to 26.4 VDC Internal impedance: approx. 2.8 kΩ Input frequency: 1 kHz max.

**Outputs**

Item	G9SX-LM224-F10-__
Safety solid state output	P channel MOS FET transistor output Load current: 0.8 A DC max.
Safety speed detection output	P channel MOS FET transistor output Load current: 0.3 A DC max.
External indicator output	PNP transistor output Load current: 100 mA max.



**OMRON EUROPE B.V.** Wegalaan 67-69, NL-2132 JD, Hoofddorp, The Netherlands. Tel: +31 (0) 23 568 13 00 Fax: +31 (0) 23 568 13 88 [www.industrial.omron.eu](http://www.industrial.omron.eu)

**Austria**

Tel: +43 (0) 2236 377 800  
[www.industrial.omron.at](http://www.industrial.omron.at)

**Belgium**

Tel: +32 (0) 2 466 24 80  
[www.industrial.omron.be](http://www.industrial.omron.be)

**Czech Republic**

Tel: +420 234 602 602  
[www.industrial.omron.cz](http://www.industrial.omron.cz)

**Denmark**

Tel: +45 43 44 00 11  
[www.industrial.omron.dk](http://www.industrial.omron.dk)

**Finland**

Tel: +358 (0) 207 464 200  
[www.industrial.omron.fi](http://www.industrial.omron.fi)

**France**

Tel: +33 (0) 1 56 63 70 00  
[www.industrial.omron.fr](http://www.industrial.omron.fr)

**Germany**

Tel: +49 (0) 2173 680 00  
[www.industrial.omron.de](http://www.industrial.omron.de)

**Hungary**

Tel: +36 1 399 30 50  
[www.industrial.omron.hu](http://www.industrial.omron.hu)

**Italy**

Tel: +39 02 326 81  
[www.industrial.omron.it](http://www.industrial.omron.it)

**Netherlands**

Tel: +31 (0) 23 568 11 00  
[www.industrial.omron.nl](http://www.industrial.omron.nl)

**Norway**

Tel: +47 (0) 22 65 75 00  
[www.industrial.omron.no](http://www.industrial.omron.no)

**Poland**

Tel: +48 (0) 22 645 78 60  
[www.industrial.omron.pl](http://www.industrial.omron.pl)

**Portugal**

Tel: +351 21 942 94 00  
[www.industrial.omron.pt](http://www.industrial.omron.pt)

**Russia**

Tel: +7 495 648 94 50  
[www.industrial.omron.ru](http://www.industrial.omron.ru)

**South-Africa**

Tel: +27 (0)11 579 2600  
[www.industrial.omron.co.za](http://www.industrial.omron.co.za)

**Spain**

Tel: +34 913 777 900  
[www.industrial.omron.es](http://www.industrial.omron.es)

**Sweden**

Tel: +46 (0) 8 632 35 00  
[www.industrial.omron.se](http://www.industrial.omron.se)

**Switzerland**

Tel: +41 (0) 41 748 13 13  
[www.industrial.omron.ch](http://www.industrial.omron.ch)

**Turkey**

Tel: +90 216 474 00 40  
[www.industrial.omron.com.tr](http://www.industrial.omron.com.tr)

**United Kingdom**

Tel: +44 (0) 870 752 08 61  
[www.industrial.omron.co.uk](http://www.industrial.omron.co.uk)

**More Omron representatives**  
[www.industrial.omron.eu](http://www.industrial.omron.eu)

**Automation Systems**

- Programmable logic controllers (PLC) • Human machine interfaces (HMI) • Remote I/O
- Industrial PC's • Software

**Motion & Drives**

- Motion controllers • Servo systems • Inverters

**Control Components**

- Temperature controllers • Power supplies • Timers • Counters • Programmable relays
- Digital panel indicators • Electromechanical relays • Monitoring products • Solid-state relays
- Limit switches • Pushbutton switches • Low voltage switch gear

**Sensing & Safety**

- Photoelectric sensors • Inductive sensors • Capacitive & pressure sensors
- Cable connectors • Displacement & width-measuring sensors • Vision systems
- Safety networks • Safety sensors • Safety units/relay units • Safety door/guard lock switches